

(19) World Intellectual Property Organization
International Bureau



(43) International Publication Date
17 June 2010 (17.06.2010)

(10) International Publication Number
WO 2010/068793 A1

- (51) International Patent Classification:
A61M 25/00 (2006.01)
- (21) International Application Number:
PCT/US2009/067554
- (22) International Filing Date:
10 December 2009 (10.12.2009)
- (25) Filing Language: English
- (26) Publication Language: English
- (30) Priority Data:
61/121,525 10 December 2008 (10.12.2008) US
- (71) Applicant (for all designated States except US): **MICROVENTION, INC.** [US/US]; 1311 Valencia Avenue, Tustin, CA 92780 (US).
- (72) Inventor; and
(75) Inventor/Applicant (for US only): **GULACHENSKI, Joseph** [US/US]; 21126 Briarwood Lane, Trabuco Canyon, CA 92679 (US).
- (74) Agent: **FREDERICKS, Charles, E.**; Inskip Intellectual Property Group, Inc., 2281 West 190th Street, Suite 200, Torrance, CA 90504 (US).

- (81) Designated States (unless otherwise indicated, for every kind of national protection available): AE, AG, AL, AM, AO, AT, AU, AZ, BA, BB, BG, BH, BR, BW, BY, BZ, CA, CH, CL, CN, CO, CR, CU, CZ, DE, DK, DM, DO, DZ, EC, EE, EG, ES, FI, GB, GD, GE, GH, GM, GT, HN, HR, HU, ID, IL, IN, IS, JP, KE, KG, KM, KN, KP, KR, KZ, LA, LC, LK, LR, LS, LT, LU, LY, MA, MD, ME, MG, MK, MN, MW, MX, MY, MZ, NA, NG, NI, NO, NZ, OM, PE, PG, PH, PL, PT, RO, RS, RU, SC, SD, SE, SG, SK, SL, SM, ST, SV, SY, TJ, TM, TN, TR, TT, TZ, UA, UG, US, UZ, VC, VN, ZA, ZM, ZW.
- (84) Designated States (unless otherwise indicated, for every kind of regional protection available): ARIPO (BW, GH, GM, KE, LS, MW, MZ, NA, SD, SL, SZ, TZ, UG, ZM, ZW), Eurasian (AM, AZ, BY, KG, KZ, MD, RU, TJ, TM), European (AT, BE, BG, CH, CY, CZ, DE, DK, EE, ES, FI, FR, GB, GR, HR, HU, IE, IS, IT, LT, LU, LV, MC, MK, MT, NL, NO, PL, PT, RO, SE, SI, SK, SM, TR), OAPI (BF, BJ, CF, CG, CI, CM, GA, GN, GQ, GW, ML, MR, NE, SN, TD, TG).

Published:

— with international search report (Art. 21(3))

(54) Title: MICROCATHETER

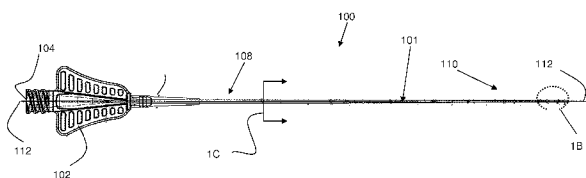

Figure 1A

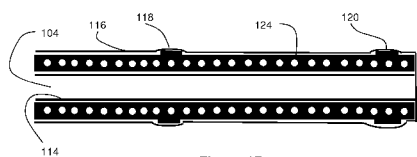

Figure 1B

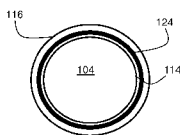

Figure 1C

(57) Abstract: A microcatheter comprises a coil formed over an inner liner. The coil is covered with a series of outer jacket segments that decrease in durometer relative to proximally adjacent segments. Preferably, these segments have angled ends that allow each segment to be inserted and bonded into the segment prior to it. The outer jacket ultimately terminates at a distal of the microcatheter with the segment having the lowest durometer.



WO 2010/068793 A1

MICROCATHETER

[0001] This application claims priority to U.S. Provisional Application Serial No. 61/121,525 filed December 10, 2008 entitled *Microcatheter*, the contents of which are incorporated in their entirety herein.

FIELD OF THE INVENTION

[0002] The present invention relates generally to medical devices and methods of manufacturing the same. More particularly, this invention relates to microcatheters and methods for making microcatheters used in performing endovascular medical procedures.

BACKGROUND OF THE INVENTION

[0003] Microcatheters are used in a variety of medical procedures for the diagnosis and treatment of conditions and diseases occurring in remote, highly tortuous vascular sites. Typically, a microcatheter is introduced to the vascular system of a patient at a first location and then is advanced through the patient's vessels until the distal end of the microcatheter reaches a desired target location.

[0004] The process of advancing the microcatheter often involves applying force proximal of its distal end. Hence, as some prior art microcatheters advance deeper into the vascular system, it can become difficult to properly push and maneuver the distal end of the microcatheter. In this respect, it is desirable that a microcatheter exhibit superior pushability and trackability. Pushability is often understood as the ability to transmit force from the proximal end of the microcatheter to the distal end of the microcatheter while minimizing or eliminating kinking. Trackability is often understood as the ability to navigate the microcatheter through tortuous vasculature.

[0005] While prior art microcatheters are typically capable of performing their intended task within a patient, it is always desirable to have improved catheter performance, such as improved trackability and pushability.

SUMMARY OF THE INVENTION

[0006] In one preferred embodiment according to the present invention, a microcatheter comprises a coil formed over an inner liner. The coil is covered with a series of outer jacket segments or transition segments that decrease in durometer relative to proximally adjacent segments. Preferably, these segments have angled ends that allow each segment to be inserted and bonded into the segment prior to it. The outer jacket ultimately terminates at a distal of the microcatheter with the segment having the lowest durometer.

BRIEF DESCRIPTION OF THE DRAWINGS

[0007] These and other aspects, features and advantages of which embodiments of the invention are capable of will be apparent and elucidated from the following description of embodiments of the present invention, reference being made to the accompanying drawings, in which

[0008] Figure 1A illustrates a side cross sectional view of a microcatheter according to a preferred embodiment of the present invention;

[0009] Figure 1B illustrates a magnified view of a distal region of the microcatheter of Figure 1A taken from area 1B;

[0010] Figure 1C illustrates a cross sectional view of the microcatheter of Figure 1A taken along lines 1C;

[0011] Figure 2A illustrates the microcatheter of Figure 1A having a curved distal region;

[0012] Figure 2B illustrates a distal region of the microcatheter from area 2B with the outer jacket partially removed;

[0013] Figure 3 illustrates different example segments forming the outer jacket of the microcatheter according to a preferred embodiment of the present invention;

[0014] Figure 4 illustrates different example segments forming the outer jacket of the microcatheter according to a preferred embodiment of the present invention;

[0015] Figure 5A illustrates a side view of two outer jacket segments with opposing or oppositely oriented diagonal angled ends;

[0016] Figure 5B illustrates a side view of two outer jacket segments with similarly oriented diagonal angled ends; and,

[0017] Figure 5C illustrates a side perspective view of a jacket segment with a diagonal angled end region.

DESCRIPTION OF EMBODIMENTS

[0018] Specific embodiments of the invention will now be described with reference to the accompanying drawings. This invention may, however, be embodied in many different forms and should not be construed as limited to the embodiments set forth herein; rather, these embodiments are provided so that this disclosure will be thorough and complete, and will fully convey the scope of the invention to those skilled in the art. The terminology used in the detailed description of the embodiments illustrated in the accompanying drawings is not intended to be limiting of the invention. In the drawings, like numbers refer to like elements.

[0019] Unless otherwise defined, all terms (including technical and scientific terms) used herein have the same meaning as commonly understood by one of ordinary skill in the art to which this invention belongs. It will be further understood that terms, such as those defined in commonly used dictionaries, should be interpreted as having a meaning that is consistent with their meaning in the context of the relevant art and will not be interpreted in an idealized or overly formal sense unless expressly so defined herein.

[0020] Figure 1A illustrates a preferred embodiment of a microcatheter 100 comprising an elongated tubular member 101 connected to a hub member 102. The proximal end 108 of the tubular member 101 is coupled to a distal end of the hub 102 and is further covered by a strain relief member 106. At least one center lumen in the

tubular member 101 is in communication with a passage within the hub 102, thereby forming catheter passage 104. In the present example embodiment, a guide wire 112 is positioned through passage 104, exiting at a distal end 110 of the tubular member.

[0021] The hub 102 is preferably bonded to the proximal portion 108 with DYMAX medical adhesion or a similar adhesive. The strain relief portion 106 may be installed onto the hub 102 by friction, adhesive or similar connection techniques.

[0022] As best seen in Figures 1B and 1C, the passage 104 is formed by an inner liner 114 about which is wound a coil 124. The coil 124 is covered by an outer jacket 116 that is formed from a plurality of different sections. Each section of the outer jacket 116 preferably has a durometer that is less than the section proximal to it. In this respect, the outer jacket 116 generally increases in flexibility towards the distal end 110 relative to the proximal end 108.

[0023] As seen in Figure 2A, the outer jacket preferably includes a hydrophilic coating along a portion of its length. Preferably, this coating is about 100-120 cm from the distal tip of the microcatheter 100.

[0024] As seen in the cross sectional view of Figure 1B and the view of Figure 2B, the distal end 110 includes two radiopaque markers 118 and 120 that are bonded between the coil layer 124 and the outer jacket 116. In one example arrangement, the marker 120 is located at or near the distal tip of the catheter 100, while the marker 118 is located about 3 cm proximal of marker band 120. As best seen in Figure 1B, these markers 118 and 120 can provide raised or elevated areas that can be used to secure an implant device such as a stent.

[0025] In one example, the microcatheter 100 is approximately 150 cm, as measured from the distal tip of the strain relief portion 106 to the distal end of the distal portion 110. The central lumen 104 has an inner diameter of approximately 0.0165 to 0.017 inches. The distal portion 110 preferably includes a region approximately 40 cm long that is approximately 1.9 French. The proximal portion 108 preferably includes a region of approximately 2.4 French. The outer jacket 116 is about .025 inches.

[0026] The inner liner 114 is preferably composed of polytetrafluoroethylene, PTFE, or other similar material and has a wall thickness in the range of about 0.0005 and 0.007 inches. Preferably, the inner liner 114 is “necked” or stretched to reduce wall thickness. This stretching can also selectively orient the molecular structure of the material and thereby impart additional performance characteristics. For example, such stretching can increase burst strength and/or increase compliance or suppleness as compared with similar, non-stretched material of the same thickness.

[0027] In this respect, a smaller portion of the microcatheter 100 is used for the inner liner 114 while the thickness of other portions can be increased without increasing the outer diameter or reducing the inner diameter of the microcatheter 100. In other words, stretching the inner liner 114 allows a different thickness ratio between the inner liner 114 and other portions of the microcatheter, such as the outer jacket 116.

[0028] For example, in a 10 system microcatheter having an inner lumen diameter in the range of about 0.0165 to 0.017 inches and an outer diameter of about 0.025 inches, there is a ratio of outer jacket 116 thickness to inner liner 114 thickness greater than about 70% and more preferably about 78% while achieving desirable performance results.

[0029] Preferably, the inner liner 114 is stretched prior to assembly by applying heat and tension to the liner 114. For example, a temperature between about 250°F and 600°F can be applied to the liner 114 while a tension between about 50g to 750g at a speed between .5 and 12 inches per minute. In another example, the inner liner 114 can be stretched at room temperature with similar or stronger forces and similar or quicker speeds.

[0030] In one preferred embodiment, the inner liner 114 can have a uniform thickness along its length. In another preferred embodiment, the inner liner 114 can increase in thickness towards its proximal end, thereby imparting additional burst strength.

[0031] The coil layer 124 is preferably formed of a round wire with an outer diameter of approximately 0.001 inch filar. The pitch of coil 124 is preferably in the range of about

0.002 to 0.004 inches. In certain embodiments of the microcatheter 100, coil 124 may also be formed with a tighter pitch.

[0032] In one example, the outer jacket 116 is formed of a plurality of segments of polyether block amide, Pebax, of varying durometer bonded to one another (e.g., heat bonded or adhesive bonding). As illustrated in Figure 5C, a first jacket segment 116A includes a biased or angled end 116D. In other words, the segment end 116D is nonperpendicular to an axis 116E along the length of the segment 116A. Preferably, this angle can be within a range of about 5-75 degrees relative to the axis 116E.

[0033] As seen in Figure 5A, segment 116A is angle-bonded within jacket segment 116B. The angled cut end 116D is oriented such that it is in an opposite rotational position relative to the angled cut end 116C. In other words, the angles of ends 116D and 116C are positioned so as to form a triangular or trapezoid shape.

[0034] Preferably, segments 116A and 116B are bonded by first placing the angled cut end 116D against angled cut end 116C. Next, a heat shrink tube is positioned over the two segments 116A and 116B. Finally, heat is applied, causing the heat shrink tube to shrink in diameter, pushing segment 116A within segment 116B. Both the heat and the force of the heat shrink tube cause the segments 116A and 116B to bond together. Finally, the heat shrink tube can be removed from the jacket segments.

[0035] As illustrated in Figure 5B, segment 116A may also be oriented such that the angled cut end 116D is positioned in the same direction and orientation as angled end 116C. While both segments are shown having angled ends, it is also contemplated that only a single segment may include an angled or biased end. The angled bonding as described in the examples of Figures 5A and 5B can reduce kinking that may otherwise occur by providing additional axial strength while maintaining flexibility.

[0036] Preferably, the outer jacket 116 has seven segments, each of which having a lower durometer than the segment proximally adjacent to it. In this respect, the outer jacket 116 becomes more flexible towards the distal end 110.

[0037] Turning to Figure 3, an example outer jacket 116 is shown having various segments. Segment 150 represents a segment on the proximal end 108 while segment

162 represents a segment on the distal end 110. In one example, the segments are composed as follows:

Jacket Segment Number	Material	Length (approximate)	Internal Diameter (approximate)	Outer Diameter (approximate)
150	Grilamid L25	85 cm	0.026 inches	0.035 inches
152	Pebax 72	5 cm	0.026 inches	0.035 inches
154	Pebax 63D1	5 cm	0.026 inches	0.033 inches
156	Pebax 55D1	5 cm	0.026 inches	0.032 inches
158	Pebax 45D2	20 cm	0.026 inches	0.031 inches
160	Pebax 45D1	15 cm	0.026 inches	0.030 inches
162	Pebax 35D	15 cm	0.026 inches	0.029 inches

[0038] Turning to Figure 4, an example outer jacket 116 is shown having various segments. Segment 164 represents a segment on the proximal end 108 while segment 176 represents a segment on the distal end 110. In one example, the segments are composed as follows:

Jacket Segment Number	Material	Length (approximate)	Internal Diameter (approximate)	Outer Diameter (approximate)
164	Grilamid L25	84 cm	0.026 inches	0.035 inches
166	Pebax 72D	5 cm	0.026 inches	0.034 inches
168	Pebax 63D1	5 cm	0.026 inches	0.033 inches
170	Pebax 55D1	35 cm	0.026 inches	0.032 inches
172	Pebax 45D2	10 cm	0.026 inches	0.031 inches
174	Pebax 45D1	15 cm	0.026 inches	0.030 inches
176	Pebax 35D	1cm	0.026 inches	0.029 inches

[0039] It will be recognized that suitable alternatives to Pebax and Grilamid are known in the field and may be employed accordingly. It will further be recognized that the wall thickness of the inner liner 114 and the outer jacket 116 may be altered so as to emphasize or enhance certain characteristics, such as the trackability, pushability, internal diameter, and/or outer diameter, of the microcatheter 100 as desired in order to perform the intended procedure.

[0040] Certain embodiments of the present invention provide for superior tip-shapability and enhanced tip-shape retention in the microcatheter 100. With respect to tip-shapeability, the microcatheter 100 is formed in a straight, i.e. not pre-shaped, configuration that can be steam-shaped as desired by a physician prior to use. The catheter 100 can be steam-shaped in a manner well known in the field. The tip-shape retention of the microcatheter 100 is greater than 55 percent. In a preferred embodiment the tip-shape retention is 58 percent and in another preferred embodiment the tip-shape retention is 67 percent.

[0041] Tip-shape retention is enhanced by employing a thinner inner liner 114 which, in turn, allows for incorporation of a thicker walled, shapeable, outer jacket 116. Tip-shape retention is further enhanced by incorporating the coil 124 having a tight pitch between the inner liner 114 and the shapeable outer jacket 116. The tight pitch coil 124 is disposed concentrically about the inner liner 114 such that the shapeable section of the microcatheter 100, i.e. the distal portion 110, is not significantly subjected to a straightening force by the coil 124. This is in contrast to prior art microcatheters that employ a braided or a longer pitch coil configuration that disposes wire or other filaments in the shapeable section of the microcatheter in a manner that exert a straightening force to the microcatheter tip.

[0042] Although the invention has been described in terms of particular embodiments and applications, one of ordinary skill in the art, in light of this teaching, can generate additional embodiments and modifications without departing from the spirit of or exceeding the scope of the claimed invention. Accordingly, it is to be understood that the drawings and descriptions herein are proffered by way of example to facilitate comprehension of the invention and should not be construed to limit the scope thereof.

What is claimed is:

1. A microcatheter comprising:
 - an elongated tube having a plurality of segments; each of said segments having a durometer that is lower than a proximally adjacent segment;
 - a coil located beneath said elongated tube and having a pitch within a range of about 0.002 to 0.004 inches; and,
 - an inner liner tube disposed beneath said coil.
2. The microcatheter of claim 1, wherein said inner liner tube is stretched.
3. The microcatheter of claim 2, wherein said inner liner tube is stretched so as to selectively orient a molecular structure of its material.
4. The microcatheter of claim 1, further comprising a hydrophilic coating disposed over said elongated tube between about 100-120 cm from a distal end of said elongated tube.
5. The microcatheter of claim 1, wherein each of said plurality of segments are angle-bonded to each other.
6. The microcatheter of claim 1, wherein said inner liner is composed of PTFE having a thickness in the range of about 0.0005 to about 0.007 inches.
7. A microcatheter sized for accessing a vasculature of a patient, comprising:
 - a first tube segment having a first axis along its length and a first angled end having a first nonperpendicular angle relative to said first axis; and
 - a second tube segment;wherein said angled end is disposed within said second tube segment, forming an elongated tube; said elongated tube having a passage open near a distal and proximal end of said elongated tube.

8. The microcatheter of claim 7, wherein said second tube segment further comprises a second axis along its length and a second angled end having a second nonperpendicular angle relative to said second axis.

9. The microcatheter of claim 8, wherein said first nonperpendicular angle and said second nonperpendicular angle are positioned in an opposite orientation relative to each other.

10. The microcatheter of claim 8, wherein said first nonperpendicular angle and said second nonperpendicular angle are positioned in a matching orientation relative to each other.

11. The microcatheter of claim 8, wherein said elongated tube further comprises a plurality of tube segments at least partially disposed within at least one other of said plurality of tube segments; each of said plurality of tube segments comprising at least one angled end.

12. The microcatheter of claim 7, wherein said elongated tube further comprises a plurality of tube segments, each of which being composed of a material having a different durometer.

13. The microcatheter of claim 12, wherein said elongated tube is disposed over a coil having a pitch between about 0.002 and 0.004 inches.

14. A microcatheter comprising:

an elongated tubular jacket having a first thickness; and,

an inner tubular liner having a second thickness and being disposed within said elongated tubular jacket;

wherein said elongated tubular jacket has an outer diameter of about .025 inches; and,

wherein the ratio between said first thickness and said second thickness is greater than 70%.

15. The microcatheter of claim 14, wherein said ratio between said first thickness and said second thickness is 78%.
16. The microcatheter of claim 14, further comprising a coiled wire disposed between said elongated tubular jacket and said inner tubular liner.
17. The microcatheter of claim 14, wherein said inner tubular liner comprises a material that has been stretched.
18. The microcatheter of claim 14, wherein said inner tubular liner comprises PTFE.
19. The microcatheter of claim 14, wherein said elongated tubular jacket is composed of a plurality of angle-bonded jacket segments.
20. The microcatheter of claim 14, wherein said inner tubular liner comprises a stretched PTFE material.

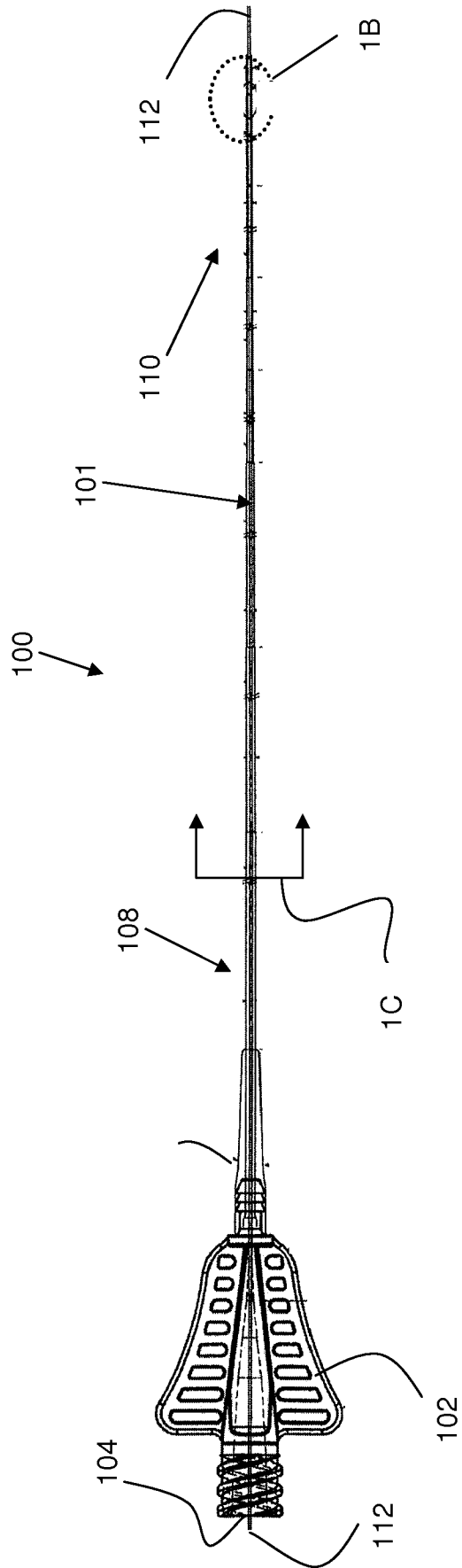

Figure 1A

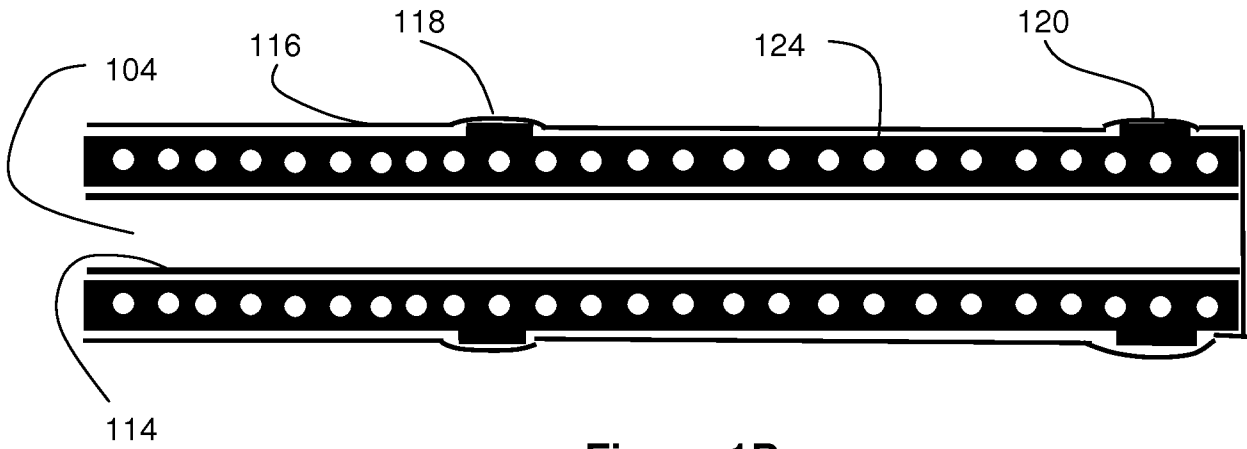

Figure 1B

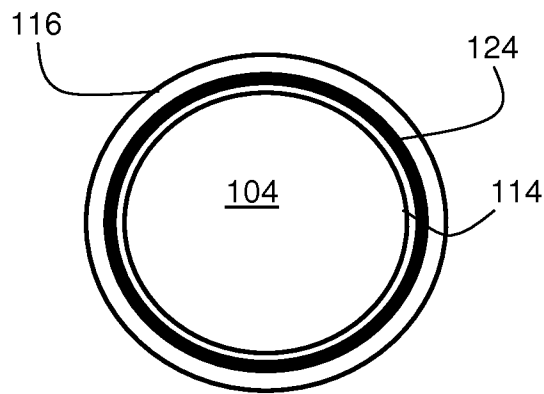

Figure 1C

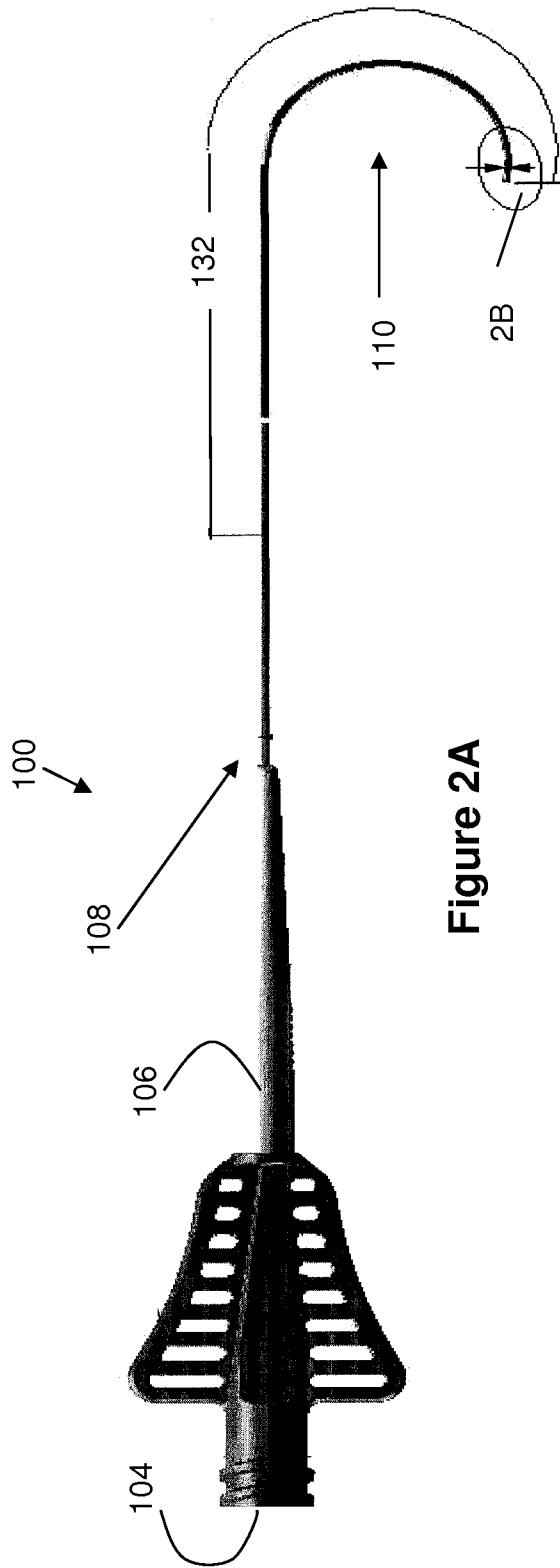

Figure 2A

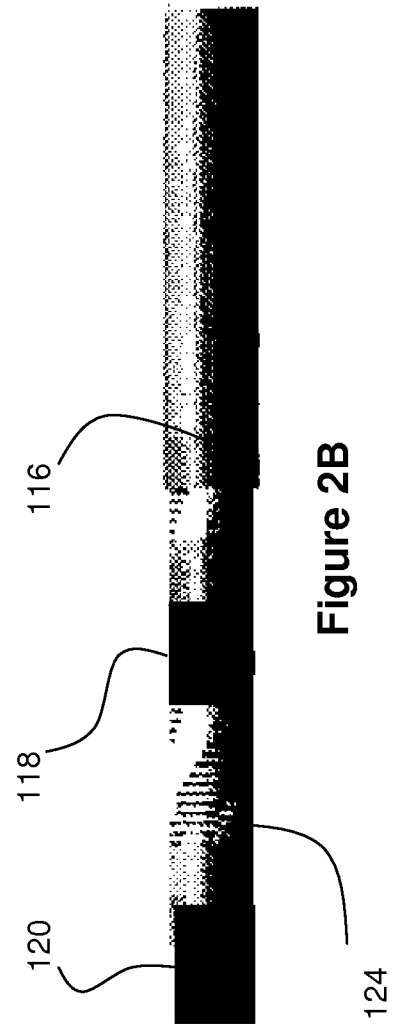

Figure 2B

150	152	154	156	158	160	162
-----	-----	-----	-----	-----	-----	-----

Figure 3

164	166	168	170	172	174	176
-----	-----	-----	-----	-----	-----	-----

Figure 4

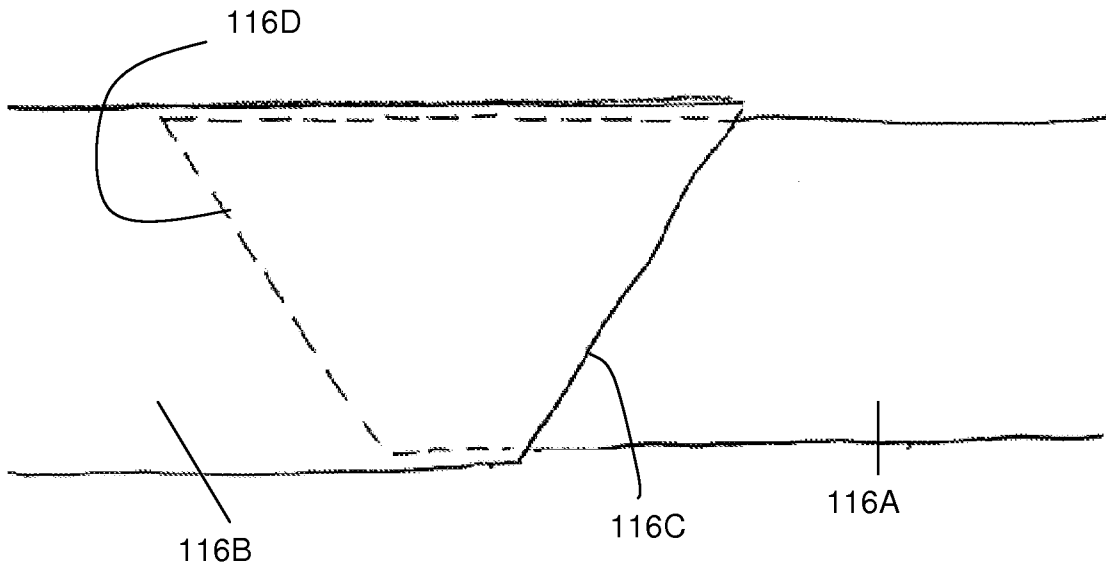

Figure 5A

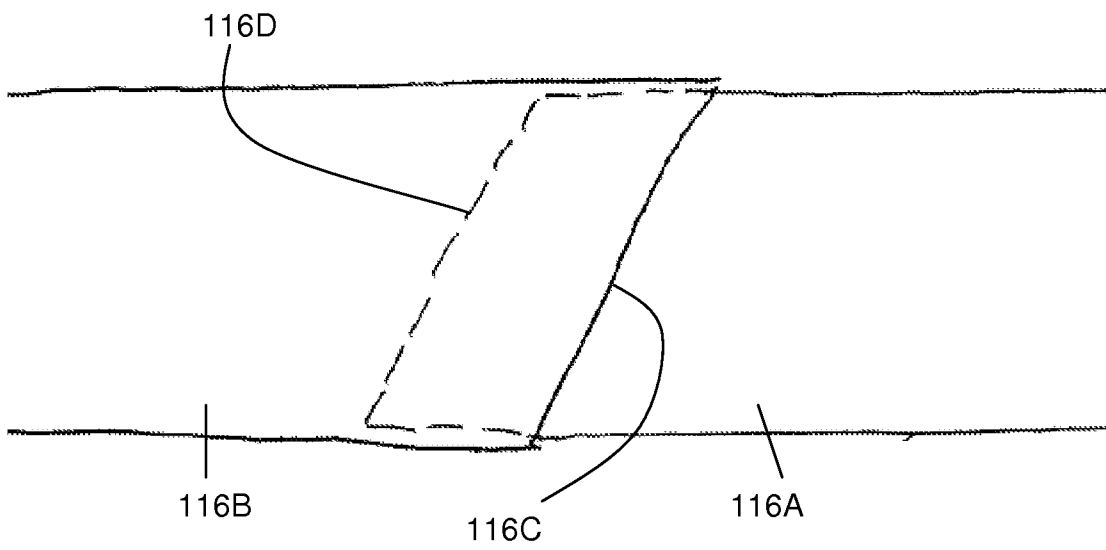

Figure 5B

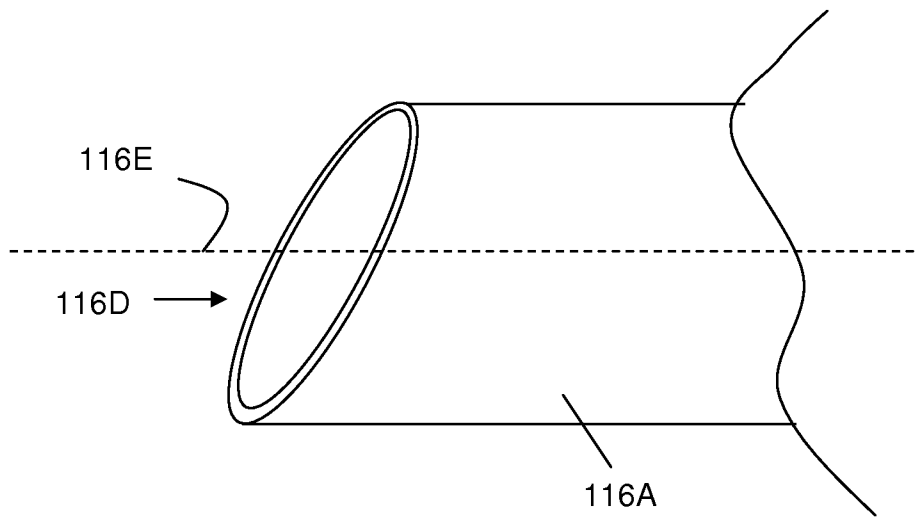

Figure 5C

INTERNATIONAL SEARCH REPORT

International application No.

PCT/US2009/067554

A. CLASSIFICATION OF SUBJECT MATTER IPC(8) - A61M 25/00 (2010.01) USPC - 604/525 According to International Patent Classification (IPC) or to both national classification and IPC		
B. FIELDS SEARCHED Minimum documentation searched (classification system followed by classification symbols) IPC(8) - A61M 25/00 (2010.01) USPC - 604/523, 524, 525, 526, 533, 534 Documentation searched other than minimum documentation to the extent that such documents are included in the fields searched Electronic data base consulted during the international search (name of data base and, where practicable, search terms used) PatBase, Google Scholar		
C. DOCUMENTS CONSIDERED TO BE RELEVANT		
Category*	Citation of document, with indication, where appropriate, of the relevant passages	Relevant to claim No.
Y	US 2003/0195490 A1 (BOATMAN et al) 16 October 2003 (16.10.2003) entire document	1-20
Y	US 2006/0264905 A1 (ESKRIDGE et al) 23 November 2006 (23.11.2006) entire document	1-20
A	US 2002/0156459 A1 (YE et al) 24 October 2002 (24.10.2002) entire document	1-20
A	US 6,296,631 B2 (CHOW) 02 October 2001 (02.10.2001) entire document	1-20
<input type="checkbox"/> Further documents are listed in the continuation of Box C. <input type="checkbox"/>		
* Special categories of cited documents: "A" document defining the general state of the art which is not considered to be of particular relevance "E" earlier application or patent but published on or after the international filing date "L" document which may throw doubts on priority claim(s) or which is cited to establish the publication date of another citation or other special reason (as specified) "O" document referring to an oral disclosure, use, exhibition or other means "P" document published prior to the international filing date but later than the priority date claimed "T" later document published after the international filing date or priority date and not in conflict with the application but cited to understand the principle or theory underlying the invention "X" document of particular relevance; the claimed invention cannot be considered novel or cannot be considered to involve an inventive step when the document is taken alone "Y" document of particular relevance; the claimed invention cannot be considered to involve an inventive step when the document is combined with one or more other such documents, such combination being obvious to a person skilled in the art "&" document member of the same patent family		
Date of the actual completion of the international search 22 January 2010		Date of mailing of the international search report 03 FEB 2010
Name and mailing address of the ISA/US Mail Stop PCT, Attn: ISA/US, Commissioner for Patents P.O. Box 1450, Alexandria, Virginia 22313-1450 Facsimile No. 571-273-3201		Authorized officer: Blaine R. Copenheaver PCT Helpdesk: 571-272-4300 PCT OSP: 571-272-7774