

Dec. 1, 1953

J. W. SWARTZ

2,661,237

DRINKING FOUNTAIN ATTACHMENT FOR FAUCETS

Filed Oct. 8, 1951

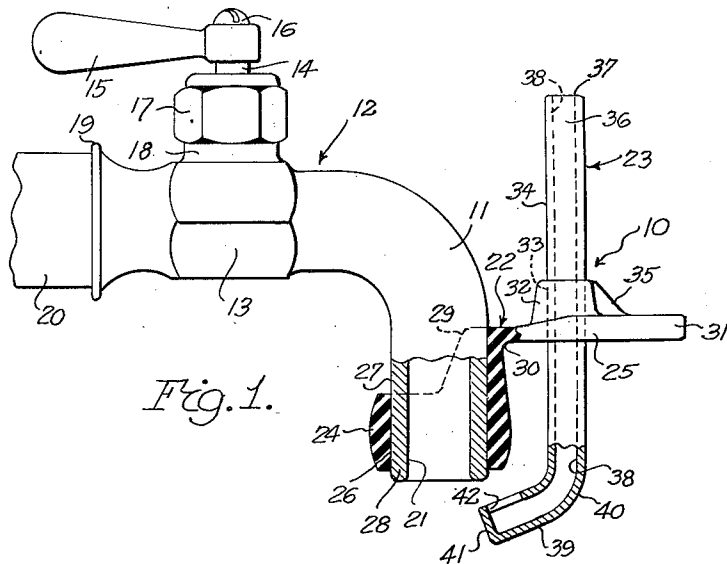

Fig. 1.

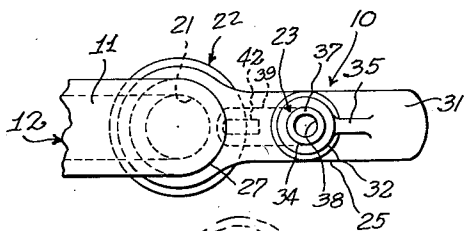

Fig. 2.

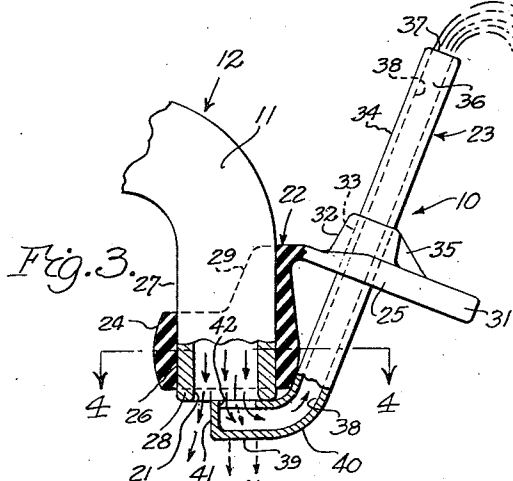

Fig. 3.

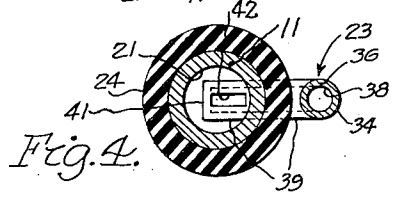

Fig. 4.

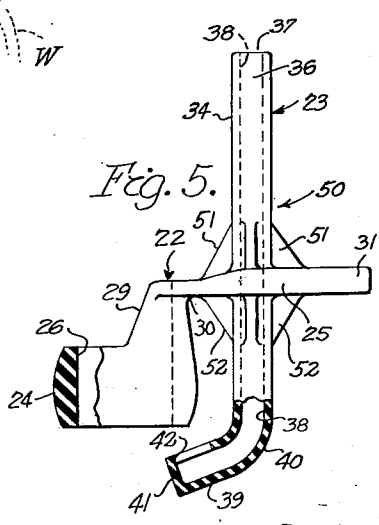

Fig. 5.

Inventor

John W. Swartz

Barthel & Bugbee

Attorneys

UNITED STATES PATENT OFFICE

2,661,237

DRINKING FOUNTAIN ATTACHMENT FOR FAUCETS

John W. Swartz, Dearborn, Mich.

Application October 8, 1951, Serial No. 250,245

1 Claim. (Cl. 299—9)

1

This invention relates to plumbing fixtures and, in particular, to drinking fountains.

One object of this invention is to provide a drinking fountain attachment for an ordinary faucet, this attachment being constantly attached to the faucet but normally held automatically in an inoperative position from which it is pushed into an operative position with a simple motion of the user's hand.

Another object is to provide a drinking fountain attachment of the foregoing character which includes a bracket of resilient material which is clamped or sprung onto the spout of the faucet and which holds a fountain tube in either its operative or inoperative position, as desired.

Another object is to provide a drinking fountain attachment of the foregoing character wherein the bracket and the fountain tube are molded integrally from a single piece of resilient material, such as rubber, synthetic rubber or synthetic plastic.

Other objects and advantages of the invention will become apparent during the course of the following description of the accompanying drawings, wherein:

Figure 1 is a side elevation, partly in central vertical section, of a drinking fountain attachment mounted on a conventional faucet, according to one form of the invention, with the fountain tube in its inoperative position;

Figure 2 is a fragmentary top plan view of the drinking fountain attachment shown in Figure 1, as attached to the faucet spout, with the remainder of the faucet omitted to conserve space;

Figure 3 is a fragmentary side elevation, partly in central vertical section, similar to Figure 1 but with the fountain tube tilted into its operative position;

Figure 4 is a horizontal section taken along the line 4—4 in Figure 3; and

Figure 5 is a side elevation, partly in central vertical section, of a modified drinking fountain attachment wherein the bracket and fountain tube are molded from a single piece of resilient material.

In general, the drinking fountain attachment of the present invention consists of a bracket, preferably of resilient material, having an opening for receiving the spout of a conventional faucet, and an arm in which a fountain tube is resiliently mounted. The arm normally holds the fountain tube in an inoperative position out of the path of the stream of water emerging from the faucet spout, but the fountain tube may be tilted into the path of the water by

2

pressing the finger upon the outer end of the bracket arm. A modification shown in Figure 5 is similar to the principal form of the invention, except that the attachment is molded in a single piece of resilient material, such as rubber, synthetic rubber or synthetic plastic.

Referring to the drawing in detail, Figure 1 shows a drinking fountain attachment, generally designated 10, adapted to be attached to the spout 11 of a conventional faucet 12 having the usual valve casing 13 with a rotary valve member 14 which is swung to and fro between its open and closed positions by means of a handle 15 attached as at 16 to the valve member 14. The valve member 14 and its associated parts are connected to the valve casing 13 by the usual threaded collar nut 17 which is threaded upon the upstanding tubular portion 18 of the valve casing 13. The faucet 12 has a connecting portion 19 by which it is attached to the water supply pipe 20 in the usual manner, as by a threaded joint. Consequently, when the valve member 14 is rotated to its open position by means of the handle 15, a stream of water emerges from the bore or passageway 21 in the faucet spout 11.

The drinking fountain attachment 10 consists generally of a bracket 22 and a fountain tube 23 mounted thereon. The bracket 22 in turn consists of a clamping ring portion 24 and an arm portion 25 which are preferably molded integrally in a single piece of resilient material or elastic deformable material, such as natural or synthetic rubber or synthetic plastic. The clamping ring portion 24, as its name indicates, is of annular form and contains a bore 26 which encircles and snugly engages the tubular outer surface 27 of the faucet spout 11 immediately above the lower end 28 thereof. Consequently, the bore 26 is preferably made of slightly less internal diameter than the external diameter of the spout 11 near its lower end 28, so that a frictional clamping engagement results when the clamping ring 24 is pushed upward over the outer surface 27 near the lower end 28 of the faucet spout 11.

The clamping ring portion 24 has an upstanding forward part 29 to which, as at 30, the arm portion 25 is directly attached. The arm portion 25 extends forward in an approximately horizontal position and terminates in a finger piece or handle portion 31. The latter serves as a handle or finger grip by which the device is operated, as described below in connection with the operation of the invention. Intermediate the finger piece 31 and the junction 30 between the arm portion 25 and the clamping ring por-

3

tion 24, the arm portion 25 is provided with an upstanding boss 32 having a vertical bore 33 which snugly receives the fountain tube 23 with a frictional clamping grip. Consequently, the bore 33 is made of slightly smaller diameter than the diameter of the outer surface 34 of the fountain tube 23 so as to provide this resilient clamping grip upon the said outer surface 34. A web or rib 35 reinforces the finger piece portion 31 and extends from the latter to the top of the boss 32.

The fountain tube 23 is, as its name indicates, of tubular form with a straight vertical upper portion 36 having an upper end 37 and a bore 38 leading to an inclined lower portion 39 joined to the upper portion 36 by a bend 40. The lower end of the tube bore 38 is closed by an end wall 41 and adjacent the end wall 41 on the upper side of the lower portion 39 is an elongated hole 42 for receiving the water emerging from the passageway 21 of the faucet spout 11.

The modified drinking fountain attachment 50 shown in Figure 5 is generally similar to the form of the invention shown in Figures 1 to 4 inclusive, except that the fountain tube 23 is molded integral with the bracket 22 rather than being made as a separate element frictionally held therein, as in Figures 1 to 4 inclusive. Similar parts are therefore designated with the same reference numerals in Figures 1 and 5. The fountain tube 23 is strengthened at its junction with the arm portion 25, however, by oppositely-extending webs or ribs 51 and 52 located respectively above and below the arm portion 25. The entire drinking fountain attachment 50 is thus molded in a single piece from resilient material, such as elastic deformable material, particularly natural or synthetic rubber or synthetic plastic.

In the operation of the invention, either of the two-piece form shown in Figure 1 or the one-piece form of Figure 5, the attachment is mounted on the faucet spout 11 by pushing the clamping ring portion 24 upward over the faucet spout outer surface 27 near the lower end 28 of the faucet 12. Due to the fact that the clamping ring portion bore 26 is of slightly smaller internal diameter than the external diameter of the faucet spout outer surface 27, the spout 11 enlarges and expands the clamping ring portion 24 as the latter is pushed over the lower end 28 of the spout 11. This results in the clamping ring portion 24 gripping the spout 11 with a strong frictional grip which may be made as powerful as desired merely by establishing the proper ratio between the inner diameter of the bore 26 and the outer diameter of the outer surface 27, according to the characteristics of the particular resilient material from which the bracket 22 is manufactured.

With the drinking fountain attachment 10 thus mounted in position upon the faucet 12, the resilience of the bracket 22 at the junction 30 between the clamping ring portion 24 and the arm portion 25 automatically swings the fountain tube 23 into its vertical or inoperative position with the hole 42 in the lower portion

4

39 of the fountain tube 23 swung forward out of the path of the stream of water emerging from the faucet spout bore or passageway 21 when the valve member 14 is swung to its open position by means of the handle 15. When the user desires to take a drink he either grasps the fingerpiece portion 31 between his thumb and index finger, or merely presses one fingertip downward upon the fingerpiece portion 31. In either case, this downward pressure upon the fingerpiece portion 31 swings the arm portion 25 downward and the lower fountain tube portion 49 from its vertical or inoperative position (Figure 1) to its inclined or operative position (Figure 3). At the same time, the user turns on the water by swinging the valve handle 15 to its open position. The water then emerges from the bore or passageway 21 of the faucet spout 11, as indicated by the arrows in Figure 3, a portion of the water being intercepted by the lower fountain tube portion 39. The intercepting water passes through the elongated hole 42, and by reason of the pressure with which it emerges from the faucet spout 11, is forced upward through the bore 38 of the fountain tube 33 and emerges at the upper end thereof in a fountain W, as shown in Figure 3.

After the user has finished drinking, he merely releases the finger piece portion 31, whereupon the natural resilience of the bracket arm portion 25 at its junction 30 with the clamping ring 24 causes the arm portion 25 to swing upward into the inoperative position of Figure 1, withdrawing the lower drinking tube portion 39 and the elongated hole 42 from the path of the stream of water emerging from the faucet spout 11.

What I claim is:

A drinking fountain attachment for mounting upon a faucet spout, said attachment comprising a resiliently-mounted bracket member of elastic deformable material having a clamping portion adapted to clampingly engage the faucet spout adjacent the discharge end thereof, said bracket member having an arm portion projecting therefrom, and a fountain tube mounted in an approximately upright position on said arm portion and having a bent lower end portion with a water inlet port therein, and swingable in a substantially vertical plane around a substantially horizontal pivot axis relatively to said clamping portion, and said end portion of said fountain tube being normally disposed out of alignment with said discharge end of said spout and selectively movable in response to such swinging of said fountain tube into and out of the path of the water emerging from said faucet spout.

JOHN W. SWARTZ.

References Cited in the file of this patent

UNITED STATES PATENTS

Number	Name	Date
1,133,871	Mace -----	Mar. 30, 1915
1,224,084	Duncan -----	Apr. 24, 1917
1,772,209	Cross -----	Aug. 5, 1930
1,835,428	Rathbun -----	Dec. 8, 1931