

W. J. HERRBOLD & C. KEELAN.
 MACHINE FOR TREATING PAPER STOCK.
 APPLICATION FILED NOV. 23, 1918.

1,298,207.

Patented Mar. 25, 1919.
 3 SHEETS—SHEET 1.

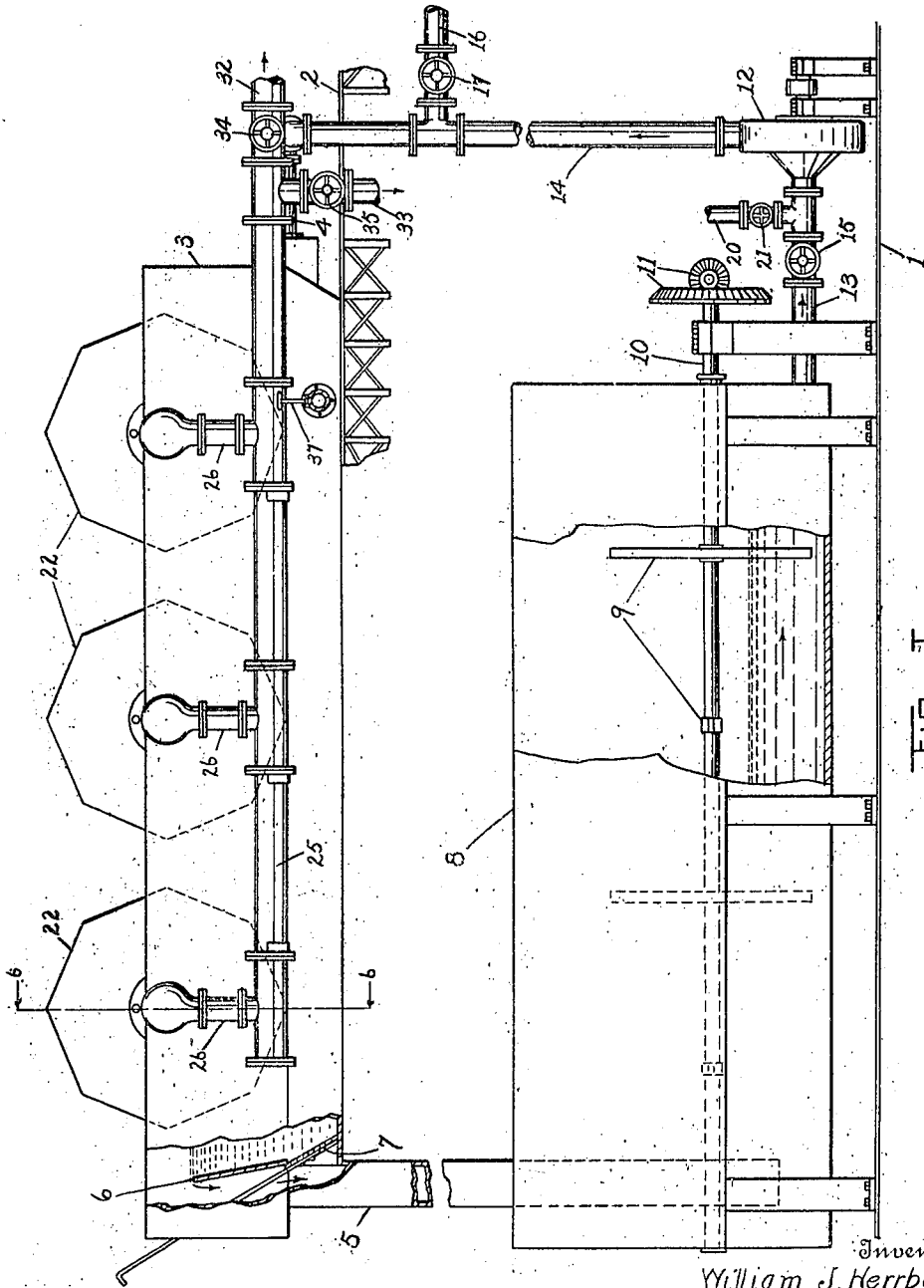

FIG. 1.

Witnesses
Lenn Gilman
Fred Ullrich

Inventor
 William J. Herrbold
 Charles Keelan

By *Chappell & Earl*
 Attorneys

W. J. HERRBOLD & C. KEELAN.
 MACHINE FOR TREATING PAPER STOCK.
 APPLICATION FILED NOV. 23, 1918.

1,298,207.

Patented Mar. 25, 1919.
 3 SHEETS—SHEET 2.

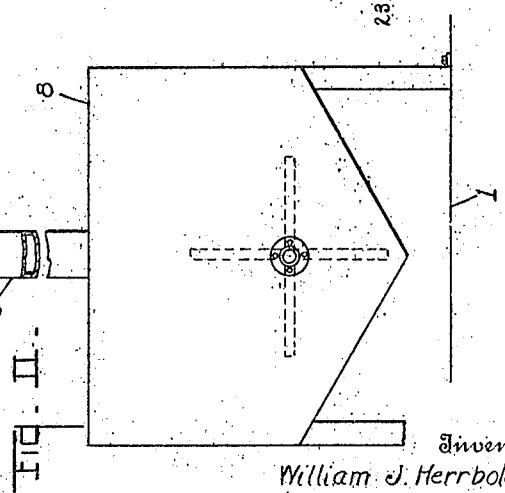
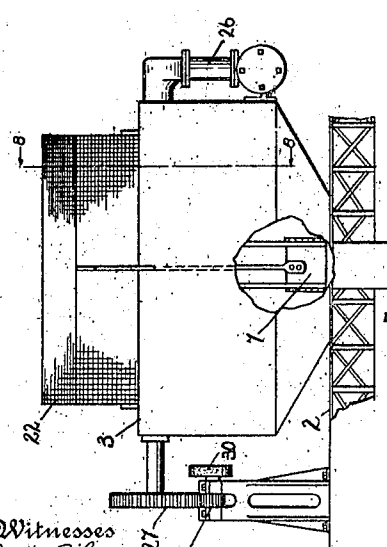
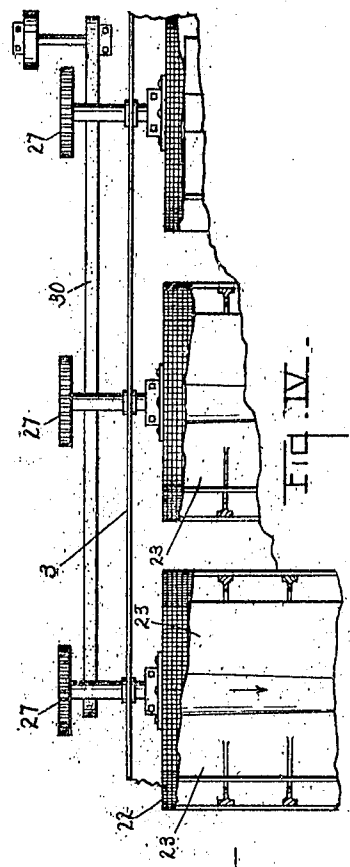
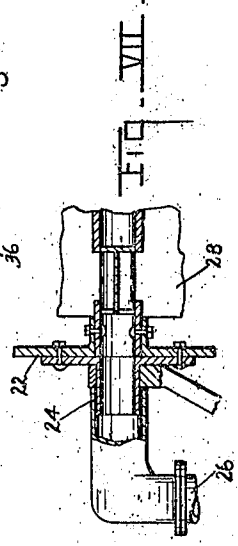
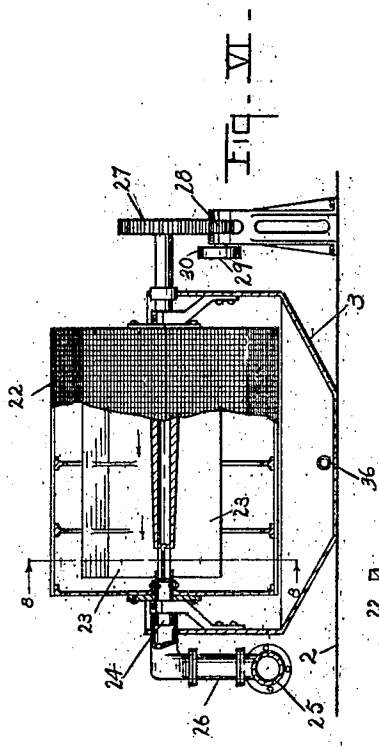

Witnesses
 Lynn Gulman
 Fred Ullrich

Inventor
 William J. Herrbold
 Charles Keelan.

By *Chappell & Co.*
 Attorneys

W. J. HERRBOLD & C. KEELAN.
 MACHINE FOR TREATING PAPER STOCK.
 APPLICATION FILED NOV. 23, 1918.

1,298,207.

Patented Mar. 25, 1919.

3 SHEETS—SHEET 3.

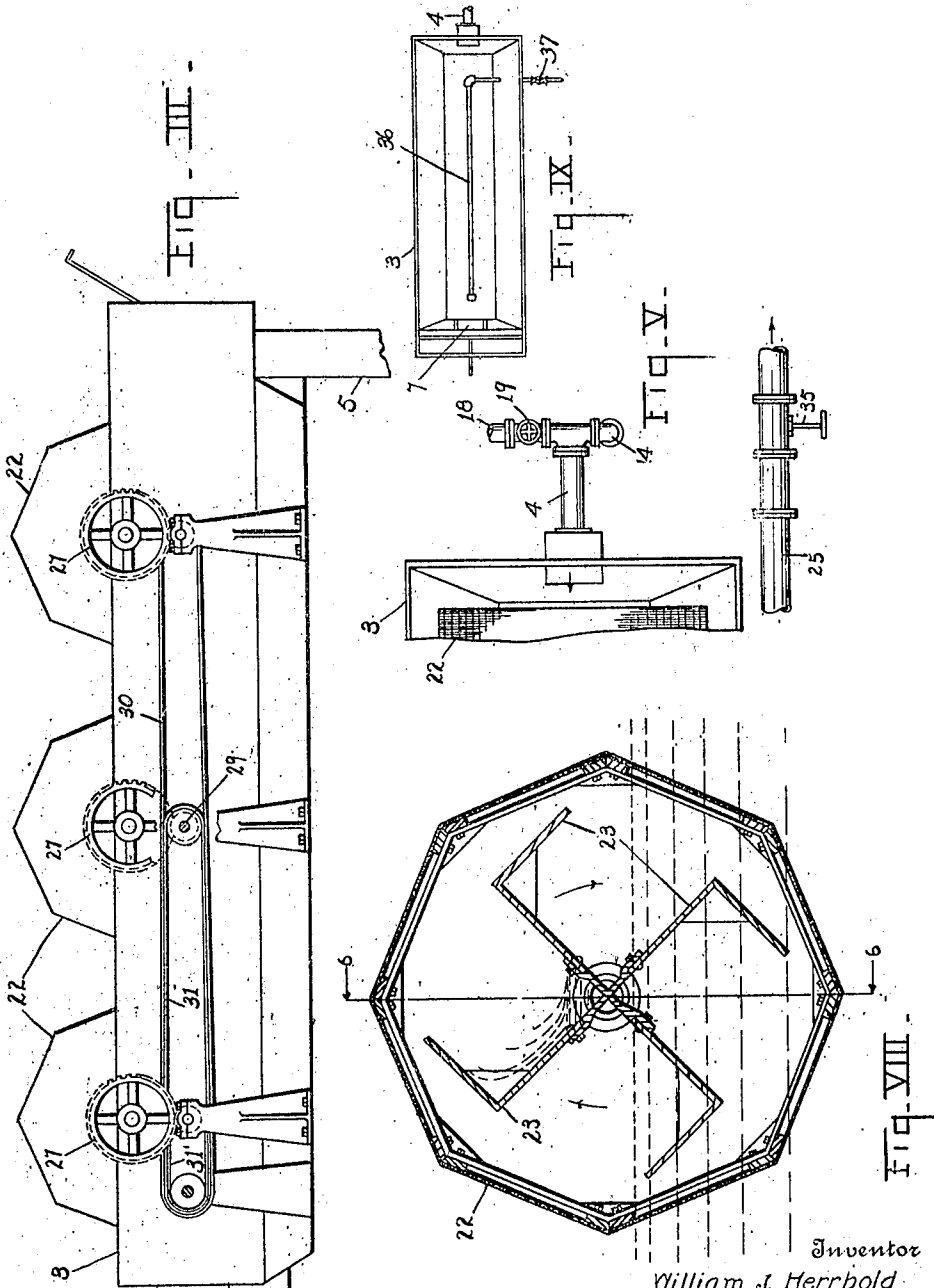

Witnesses
 Lem Gilman
 Fred Ullrich

Inventor
 William J. Herrbold
 Charles Keelan

By *Chappell & Co.*
 Attorneys

UNITED STATES PATENT OFFICE.

WILLIAM J. HERRBOLD AND CHARLES KEELAN, OF KALAMAZOO, MICHIGAN.

MACHINE FOR TREATING PAPER-STOCK.

1,298,207.

Specification of Letters Patent.

Patented Mar. 25, 1919

Application filed November 23, 1918. Serial No. 263,811.

To all whom it may concern:

Be it known that we, WILLIAM J. HERRBOLD and CHARLES KEELAN, citizens of the United States, residing at Kalamazoo, 5 county of Kalamazoo, State of Michigan, have invented certain new and useful Improvements in Machines for Treating Paper-Stock, of which the following is a specification.

10 This invention relates to improvements in machines for treating paper stock.

The main objects of this invention are:

15 First, to provide an improved machine for washing paper stock whereby a large proportion of the liquor, for example, de-inking liquor, with which the stock has been previously treated may be saved or recovered.

20 Second, to provide an improved machine for washing paper stock which may also be effectively used for bleaching.

Third, to provide an improved machine for washing paper stock which is very effective and of large capacity.

25 Further objects, and objects relating to structural details, will definitely appear from the detailed description to follow.

30 We accomplish the objects of our invention by the devices and means described in the following specification. The invention is clearly defined and pointed out in the claims.

35 A structure which is a preferred embodiment of our invention is clearly illustrated in the accompanying drawing, forming a part of this specification, in which:

40 Figure I is a detail side elevation of a structure embodying the features of our invention, various parts thereof being shown mainly in conventional form.

Fig. II is an end elevation looking from the left of Fig. I.

45 Fig. III is a detail side elevation of the washing tank and the screen driving mechanism for the rotary screens looking from the left of Fig. II.

Fig. IV is a detail plan view of the washing tank.

50 Fig. V is a detail plan view of the inlet end of the washing tank.

Fig. VI is a detail view partially in transverse section on a line corresponding to line 6—6 of Fig. I.

55 Fig. VII is an enlarged detail of a portion of the parts shown in Fig. VI.

Fig. VIII is a detail section on a line corresponding to line 8—8 of Fig. III.

Fig. IX is a plan view of the washing tank with the rotary screens omitted illustrating the arrangement of the spray pipe 60 in the bottom thereof.

In the drawing, similar reference characters refer to similar parts throughout the several views, and the sectional views are taken looking in the direction of the little 65 arrows at the ends of the section lines.

Referring to the drawing, 1 represents one floor of a building and 2 a floor above. The washing tank 3 is arranged on the upper floor and is provided with an inlet 4 at one 70 end and a discharge conduit 5 at the other. The tank is provided with an overflow connection at 6 to this conduit and also a gate connection 7.

75 On the lower floor we arrange a stock tank 8 to which the conduit 5 delivers. This stock tank is provided with agitators 9 mounted on a shaft 10 driven by suitable means, as the gears 11. The driving connections are not illustrated as they form no part 80 of this invention.

85 The circulating pump 12, shown conventionally in Fig. I, is connected to the stock tank by a pipe 13. The discharge pipe 14 of the pump 12 is connected to the inlet 4 of the washing tank so that the stock may be circulated through the washing tank and stock tank. The pipe 13 is provided with a valve 15 so that the stock may be retained in the stock tank. The discharge pipe 14 is 90 provided with a delivery connection 16 controlled by the valve 17 so that when the treatment of the stock is completed it may be delivered to the supply tank.

95 The inlet pipe 4 is connected by a pipe 18, controlled by a valve 19, to the source of supply of the stock, such as a de-fibering or de-inking machine or otherwise, as may be desired. When the stock is being circulated through the pump 12 to the washer and the 100 stock tank 8 this valve 19 is closed.

105 The pipe 13 preferably has a connection 20 with a water supply, such as a water main, this connection being controlled by a valve 21.

110 Within the washing tank we provide a plurality of rotary screens 22 having buckets 23 therein delivering through the tubular journals 24 to the waste pipe 25, each screen being provided with a connecting

pipe 26 to this waste pipe. The structural details of the rotary screens are not a part of our present invention and are, therefore, not described with further detail.

5 The screens are provided with gears 27 meshing with pinions 28 driven from the pulleys 29 and belts 30 and 31 and 31'—see Figs. III and VI, so that the screens are all driven in the same direction carrying
10 the stock toward the rear of the tank and also removing the dirty water.

The waste pipe has a connection 32 to a liquor storage tank, the tank not being illustrated, and a connection 33 to a sewer or
15 drain. These connections are controlled by valves 34 and 35 respectively.

To supply fresh water and to agitate the stock to prevent it settling within the storage tank we provide a spray pipe 36 arranged centrally and longitudinally of the
20 tank below the rotary screens and controlled by the valve 37.

With this arrangement of parts the apparatus may be operated as follows: Assuming
25 that it is desired to wash stock that has been treated with de-inking or other liquor which it is desired to recover, the stock is delivered to the washing tank from the source of supply to the valve 19. The valve 15 being
30 closed the stock will be collected in the stock tank 8 and the liquor drawn off by means of the screens through the waste pipe 32 to the liquor tank, the valve 24 being open and the valve 35 being closed. When a batch has
35 been run into the stock tank 8 the valves 19 and 34 are closed, the valve 35 to the drain or sewer opened, the valves 15, 20 and 37 opened and the pump started, the valve 17 being closed, and the stock is circulated with
40 the washing water through the washing tank, the dirty water being screened off. When the washing is completed a bleach may be added, the gate 7 opened, and the stock with the bleach circulated through the stock tank
45 with the agitator and through the pump until it is properly bleached. The bleach may be then washed out and the stock discharged through the connection 16. By proper manipulation about 75% of the stock
50 treating liquors may be recovered. The apparatus is very efficient and of large capacity.

We have illustrated and described our improvements mainly in conventional form and
55 without an attempt to maintain the relative proportion of parts. It is believed that the disclosure made will enable those skilled in the art to which our invention relates to embody or adapt the same as particular installations and capacity desired may require for
60 most efficient results.

Having thus described our invention, what we claim as new and desire to secure by Letters Patent, is:

65 1. In a machine for treating paper stock,

the combination of a washing tank provided with a stock inlet at one end and a discharge conduit at the other, said tank having an overflow connection and a gate connection to said discharge conduit, a stock tank to
70 which said conduit delivers disposed below said washing tank, an agitator for said stock tank, a series of rotary screens disposed in said washing tank and provided with internal buckets, a spray pipe disposed in said
75 washing tank below said screens to agitate the stock therein and supply water thereto, a waste pipe to which said buckets deliver, valves for controlling said waste pipe whereby the waste may be conducted to a recep-
80 tacle for the purpose of saving liquor or to a drain when washing stock, and a circulating pump having an inlet pipe connected to said stock tank and a discharge pipe connected to the stock inlet of said washing tank, said
85 pump inlet pipe being provided with a valve and with a water supply connection, the pump discharge pipe being provided with a stock delivery connection.

2. In a machine for treating paper stock,
90 the combination of a washing tank provided with a stock inlet at one end and a discharge conduit at the other, a stock tank to which said conduit delivers, a series of rotary
95 screens disposed in said washing tank and provided with internal buckets, a spray pipe disposed in said washing tank below said screens to agitate the stock therein and supply water thereto, a waste pipe to which said
100 buckets deliver, valves for controlling said waste pipe whereby the waste may be conducted to a receptacle for the purpose of saving liquor or to a drain when washing stock, and a circulating pump having an inlet pipe connected to said stock tank and a
105 discharge pipe connected to the stock inlet of said washing tank, said pump inlet pipe being provided with a valve.

3. In a machine for treating paper stock,
110 the combination of a washing tank provided with a stock inlet at one end and a discharge conduit at the other, said tank having an overflow connection and a gate connection to said discharge conduit, a stock tank to which
115 said conduit delivers disposed below said washing tank, an agitator for said stock tank, a rotary screen disposed in said washing tank, a waste pipe to which said screen delivers, valves for controlling said waste
120 pipe whereby the waste may be conducted to a receptacle for the purpose of saving liquor or to a drain when washing stock, and a circulating pump having an inlet pipe connected to said stock tank and a discharge
125 pipe connected to the stock inlet of said washing tank, said pump inlet pipe being provided with a valve and with a water supply connection, the pump discharge pipe being provided with a stock delivery connection.
130

4. In a machine for treating paper stock, the combination of a washing tank provided with a stock inlet at one end and a discharge conduit at the other, a stock tank to which said conduit delivers, a rotary screen disposed in said washing tank, a waste pipe to which said screen delivers, valves for controlling said waste pipe whereby the waste may be conducted to a receptacle for the purpose of saving liquor or to a drain when washing stock, and a circulating pump having an inlet pipe connected to said stock tank and a discharge pipe connected to the stock inlet of said washing tank, said pump inlet pipe being provided with a valve.

5. In a machine for treating paper stock, the combination of a washing tank provided with a stock inlet at one end and a discharge conduit at the other, said tank having an overflow connection and a gate connection to said discharge conduit, a stock tank to which said conduit delivers disposed below said washing tank, an agitator for said stock tank, a series of rotary screens disposed in said washing tank and provided with internal buckets, a spray pipe disposed in the bottom of said washing tank below said screens to agitate the stock therein and supply water thereto, a waste pipe to which said buckets deliver, and a circulating pump having its inlet connected to said stock tank and its discharge connected to the stock inlet of said washing tank.

6. In a machine for treating paper stock, the combination of a washing tank provided with a stock inlet at one end and a discharge conduit at the other, a stock tank to which said conduit delivers disposed below said washing tank, a screen for said washing tank, a waste pipe to which said screen delivers, and a circulating pump having its inlet connected to said stock tank and its

discharge connected to the stock inlet of said washing tank.

7. In a machine for treating paper stock, the combination of a washing tank provided with a stock inlet at one end and a discharge conduit at the other, said tank having an overflow connection and a gate connection to said discharge conduit, a stock tank to which said conduit delivers, an agitator for said stock tank, a screen for said washing tank, a waste pipe to which said screen delivers, valves for controlling said waste pipe whereby the waste may be conducted to a receptacle for the purpose of saving liquor or to a drain when washing stock, and a circulating pump having its inlet connected to said stock tank and its discharge connected to the stock inlet of said washing tank, the pump inlet being provided with a valve.

8. In a machine for treating paper stock, the combination of a washing tank provided with a stock inlet at one end and a discharge conduit at the other, a stock tank to which said conduit delivers, a screen for said washing tank, a waste pipe to which said screen delivers, valves for controlling said waste pipe whereby the waste may be conducted to a receptacle for the purpose of saving liquor or to a drain when washing stock, and a circulating pump having its inlet connected to said stock tank and its discharge connected to the stock inlet of said washing tank, the pump inlet being provided with a valve.

In witness whereof, we have hereunto set our hands and seals in the presence of two witnesses.

WILLIAM J. HERRBOLD. [L.S.]

CHARLES KEELAN. [L.S.]

Witnesses:

V. K. WERSEL,

W. C. FISK.