

R. P. Abernethy,
Cork Machine.

N^o 20,770.

Patented July 6, 1858.

Fig. 1.

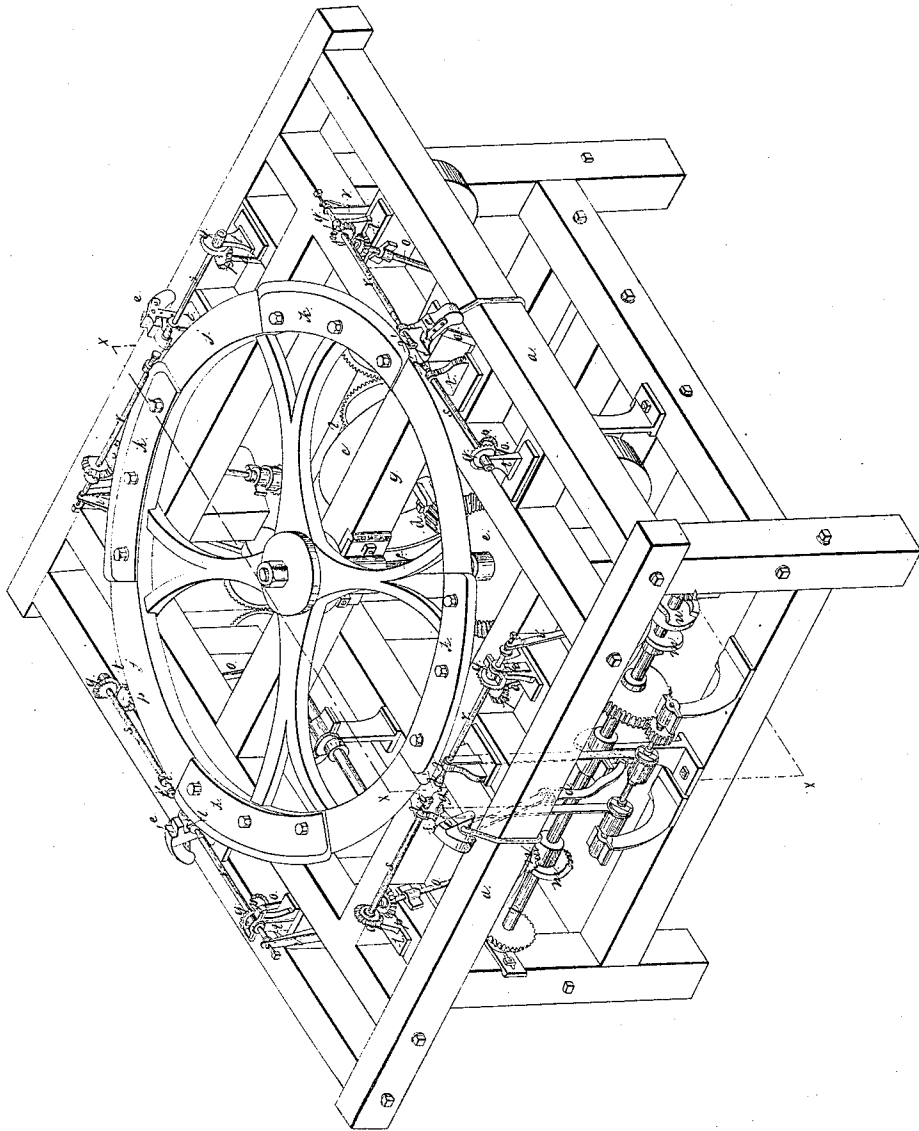

R. P. Abernethy, Cork Machine.

N^o 20,770.

Patented July 6, 1858.

Fig. 2.

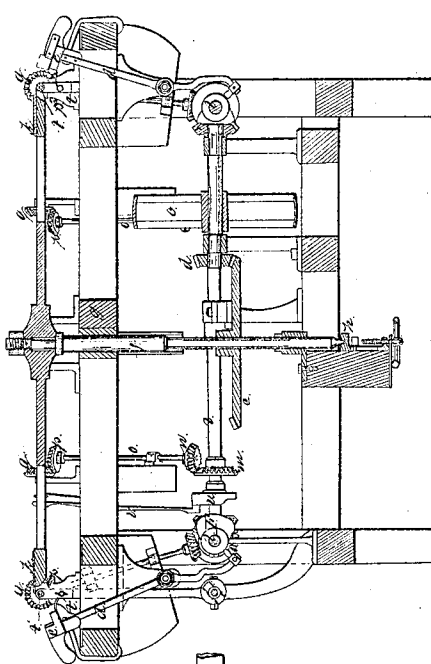
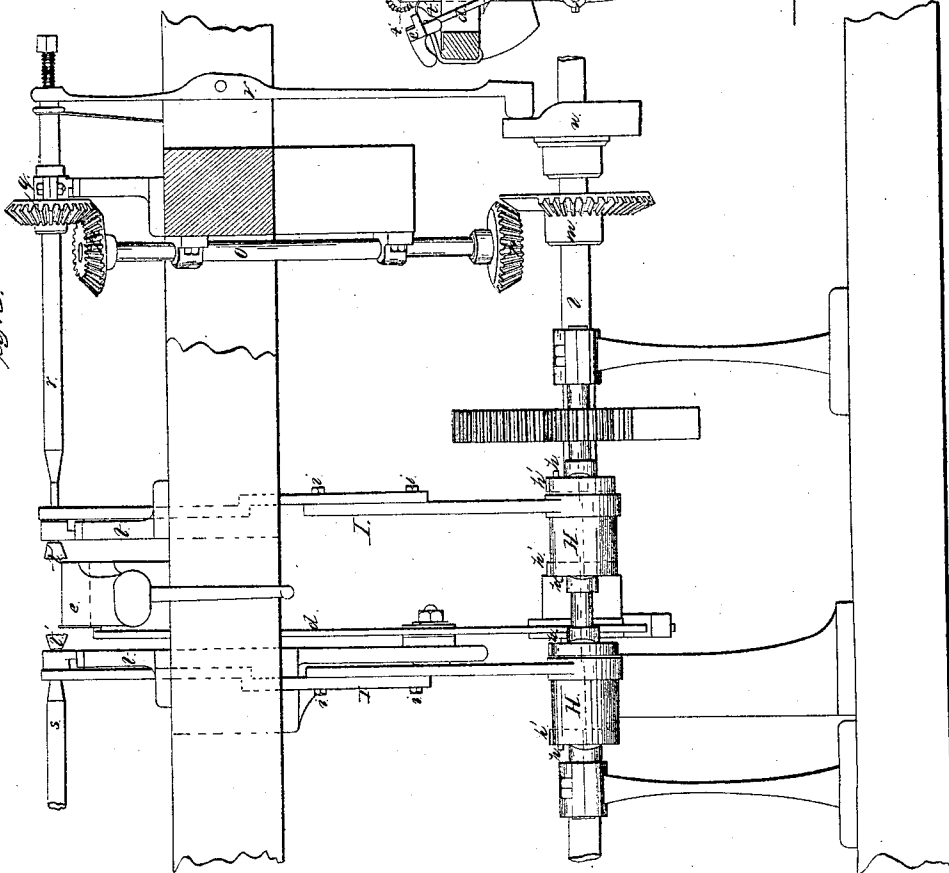

Fig. 3.



R. P. Abernethy, *3 Sheets, Sheet 3.*
Cork Machine.

N^o 20,770.

Patented July 6, 1858.

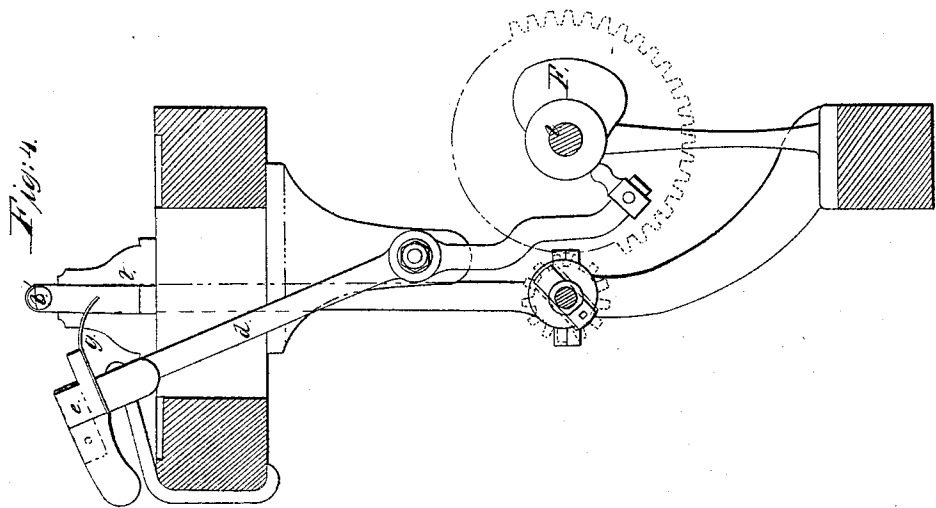
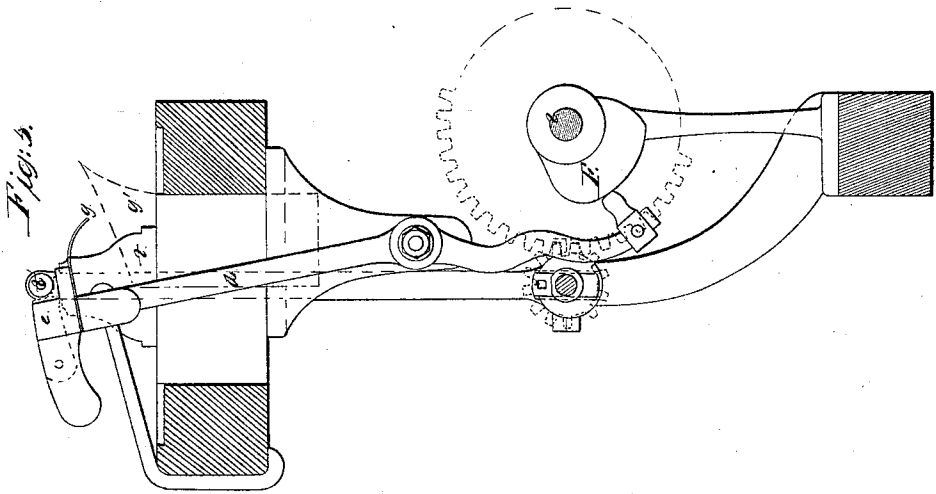

UNITED STATES PATENT OFFICE.

R. P. ABERNETHY, OF CINCINNATI, OHIO, ASSIGNOR TO UNION CORK MANUFACTURING COMPANY, OF SAME PLACE.

MACHINE FOR CUTTING CORKS.

Specification of Letters Patent No. 20,770, dated July 6, 1858.

To all whom it may concern:

Be it known that I, ROBERT P. ABERNETHY, of Cincinnati, Hamilton county, Ohio, have invented new and useful Improvements in
5 Cork-Cutting Machinery; and I hereby declare the following to be a full and exact description of the same, reference being had to the accompanying drawings, making part of this specification.

10 The first part of my invention relates to an automatic device for feeding the blank to the mandrels.

The second part of my invention relates to an automatic device for cutting oval corks.

15 In the accompanying drawings Figure 1 is an isometric view of a machine with my improvements. Fig. 2 is an axial section thereof at the plane $x x x x$, Fig. 1. Fig. 3
20 is a front view of the feeding mechanism and ovaling mechanism on an enlarged scale. Figs. 4 and 5 are side views of the same in different positions.

A, is a frame supporting a horizontal cutter wheel j , armed with four knives k . Four
25 counter shafts l , are so geared together as to revolve four times at each revolution of the cutter wheel.

Stationary but adjustable headstocks c, c' , support mandrels r, s , one of which (r) at
30 the proper moment for grasping the blank is slid forward in its bearings. Each pair of mandrels is so geared to a counter shaft as to commence rotating on the instant that the knife has entered the full length of the
35 blank, and the two mandrels together make just one revolution during the remainder of the cut, when the recession of the sliding mandrel liberates the then finished cork.

40 Journaled horizontally to the frame (so as to move in a vertical plane) is an arm d , having a rectangularly notched head e , adapted to hold the square piece or "blank," out of which a bottle cork is made. At one
45 end of this notch is a small yielding strip of metal f , of such shape as when advanced to remain clear of the stationary mandrel. This strip f , serves as a shoulder or stop for the end of the blank, its pliability permitting a slight longitudinal movement in obedience
50 to the sliding mandrel. A lip g which curves outward and downward from the head e , receives the finished cork from the mandrels

and conducts it into the discharging spout g' . An intermittent vibratory motion is given to the arm d , by means of a suitable
55 cam F , which derives its motion from the same mechanism which operates the mandrels. The arm d , with its appendages I style the "automatic feed rest d, e, f, g ."

The parts are so arranged that the rest is
60 moved up in time for the blank to be grasped by the mandrel just before the incision of the knife, when being relinquished by the cam it is retracted by spring or weight.

For making oval corks I effect a slight elevation and depression of the mandrels, twice
65 during every rotation by means of eccentrics H , connected to the mandrel shafts by rods I . In order to admit of the desired play of the mandrels their front ends occupy vertical
70 slots in the headstocks, which while restraining any lateral play permit a slight vertical oscillation of the mandrels. In order to effect these relative motions the eccentric shafts are geared to make two revolutions
75 for every revolution of the mandrels. The amount of ovaling is varied at pleasure by changing the eccentricity of the eccentric sheaves, which for this purpose may consist of rings and may be made adjustable further
80 from or nearer to concentricity with the shaft by set screws h , engaging in slotted collars h' . The rods I , are capable of being lengthened or shortened by means of screws
85 i . By this automatic mechanism thin slabs may be worked up into oval corks similar to those now made by hand.

The improvements may be used in conjunction with any forms of suitable intermittently acting cutters and mandrels.
90

I claim as new and of my invention herein:

1. In this connection, the automatic feed rest d, e, f, g , substantially as set forth.

2. Imparting to the mandrels of a cork
95 cutting machine, a compound rotary and vibratory movement by means and for the purposes substantially as set forth.

In testimony of which invention I hereunto set my hand.

R. P. ABERNETHY.

Witnesses:

GEO. H. KNIGHT,
C. STEEMER.