

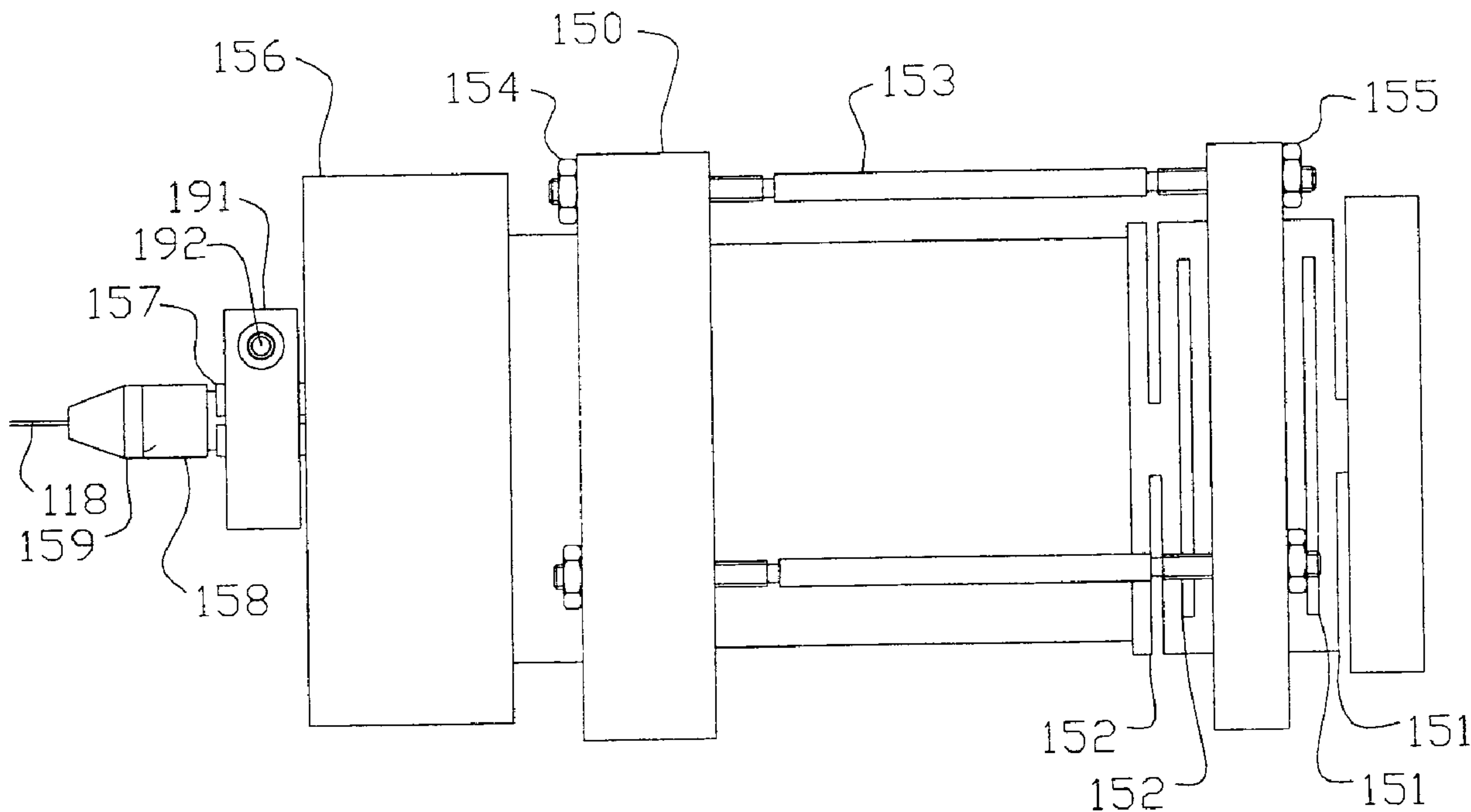

(86) Date de dépôt PCT/PCT Filing Date: 2000/11/13
 (87) Date publication PCT/PCT Publication Date: 2001/06/07
 (45) Date de délivrance/Issue Date: 2010/08/24
 (85) Entrée phase nationale/National Entry: 2002/04/29
 (86) N° demande PCT/PCT Application No.: US 2000/031165
 (87) N° publication PCT/PCT Publication No.: 2001/040746
 (30) Priorité/Priority: 1999/12/01 (US60/167,491)

(51) Cl.Int./Int.Cl. *G01J 3/18* (2006.01)
 (72) Inventeur/Inventor:
 PALUMBO, PERRY A., US
 (73) Propriétaire/Owner:
 HACH COMPANY, US
 (74) Agent: SMART & BIGGAR

(54) Titre : SPECTROMETRE CONCENTRIQUE ATTENUANT LES REFLEXIONS SPECULAIRES INTERNES
 (54) Title: CONCENTRIC SPECTROMETER WITH MITIGATION OF INTERNAL SPECULAR REFLECTIONS



(57) **Abrégé/Abstract:**

Concentric spectrometers are plagued with internal reflections due to the inherent nature of more than one optical surface possessing a common center of curvature. Reflections from optical surfaces arise when there is a difference or change in the refractive index of the media in which an optical beam or ray of a given wavelength is propagating. Internal reflections in concentric optical systems can produce a myriad of undesirable optical phenomenon at the image plane such as multiple images of an object, interference fringes, and stray light. As a result a loss in contrast or detection limit arise from such phenomenon in which light or detectable radiation that impinges on the image plane does not add to the formation of the intended image, (stray light). The present invention produces high quality images without the optical phenomenon(s) that arise from internal reflections by removing the reflected radiation from propagating through the optical system.

(12) INTERNATIONAL APPLICATION PUBLISHED UNDER THE PATENT COOPERATION TREATY (PCT)

(19) World Intellectual Property Organization
International Bureau



(43) International Publication Date
7 June 2001 (07.06.2001)

PCT

(10) International Publication Number
WO 01/40746 A1

- (51) International Patent Classification⁷: G01J 3/02
- (72) Inventor: PALUMBO, Perry, A.; 2018 Topanga Court, Ft. Collins, CO 80525 (US).
- (21) International Application Number: PCT/US00/31165
- (74) Agent: EDMUNDSON, Dean, P.; P.O. Box 710, Windsor, CO 80550 (US).
- (22) International Filing Date:
13 November 2000 (13.11.2000)
- (81) Designated States (*national*): CA, JP.
- (25) Filing Language: English
- (84) Designated States (*regional*): European patent (AT, BE, CH, CY, DE, DK, ES, FI, FR, GB, GR, IE, IT, LU, MC, NL, PT, SE, TR).
- (26) Publication Language: English
- (30) Priority Data:
60/167,491 1 December 1999 (01.12.1999) US
- (71) Applicant: HACH COMPANY [US/US]; 5600 Lingbergh Drive, Loveland, CO 80538 (US).

Published:

— With international search report.

For two-letter codes and other abbreviations, refer to the "Guidance Notes on Codes and Abbreviations" appearing at the beginning of each regular issue of the PCT Gazette.

(54) Title: CONCENTRIC SPECTROMETER WITH MITIGATION OF INTERNAL SPECULAR REFLECTIONS

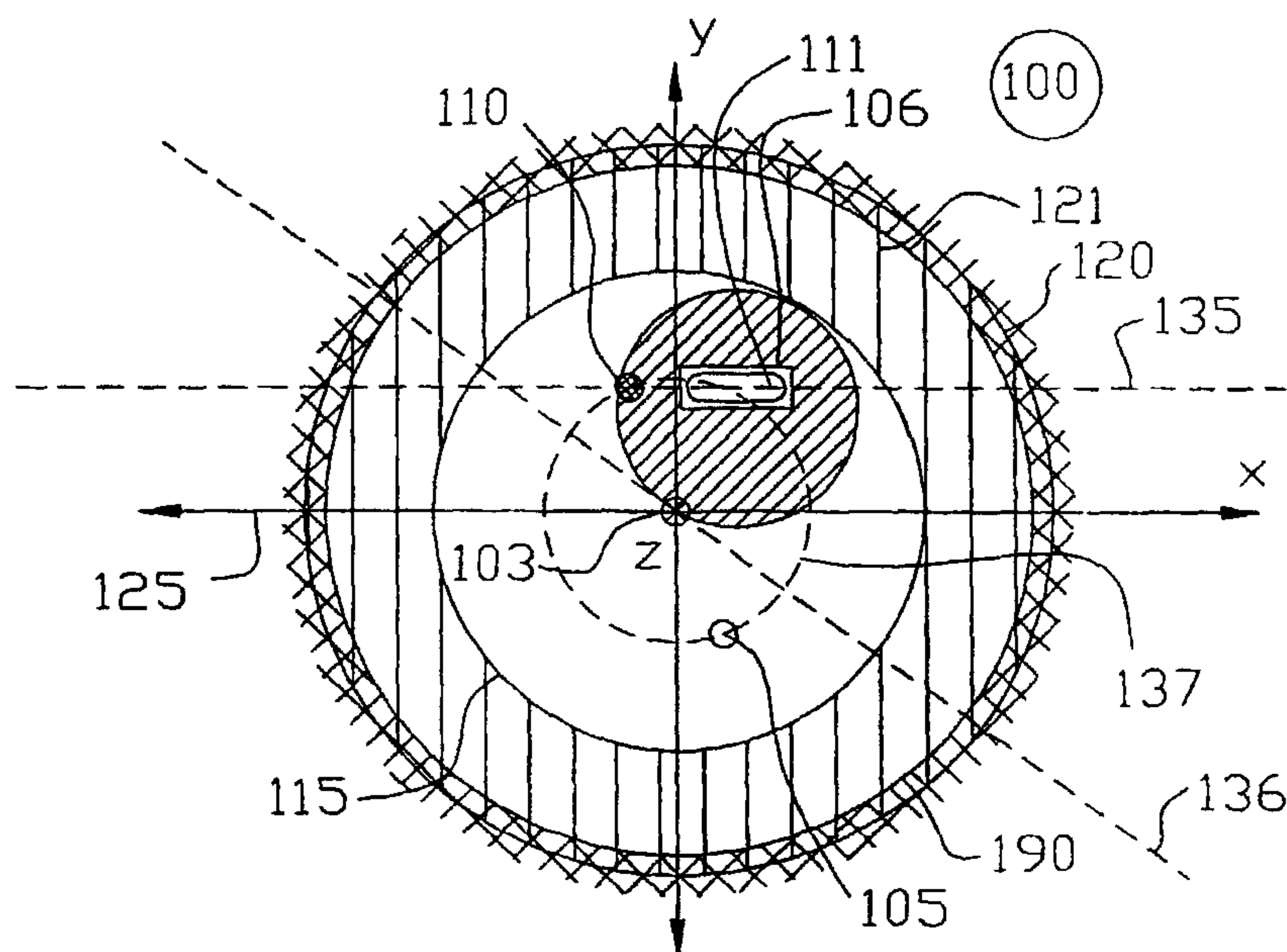

(57) Abstract: Concentric spectrometers are plagued with internal reflections due to the inherent nature of more than one optical surface possessing a common center of curvature. Reflections from optical surfaces arise when there is a difference or change in the refractive index of the media in which an optical beam or ray of a given wavelength is propagating. Internal reflections in concentric optical systems can produce a myriad of undesirable optical phenomenon at the image plane such as multiple images of an object, interference fringes, and stray light. As a result a loss in contrast or detection limit arise from such phenomenon in which light or detectable radiation that impinges on the image plane does not add to the formation of the intended image, (stray light). The present invention

produces high quality images without the optical phenomenon(s) that arise from internal reflections by removing the reflected radiation from propagating through the optical system.

WO 01/40746 A1

DescriptionConcentric Spectrometer With Mitigation of
Internal Specular ReflectionsTechnical Field

The present invention relates generally to spectrometers and spectrographs having optical elements in which the surfaces of said elements include a common center of curvature. More specifically, this invention pertains to a Dyson, "unit magnification optical system without Seidel aberrations", which includes concentric spectrometers and concentric spectrographs in which the Dyson optical system is applied.

Background Art

Concentric optical systems such as described by J. Dyson, JSOA, "Unit Magnification...Aberrations", Vol. 49, No. 7, pp. 713-716, provide large image fields free of Seidel aberrations and are thus able to form images of high quality and resolution. This optical arrangement has been applied to advantage by L. Mertz, Applied Optics, "Concentric Spectrographs", Vol. 16, No. 12, pp. 3122-3124, and W. Slutter (EP 0 862 050 A2; 1998) to spectrometers and spectrographs to produce high quality spectral dispersion of optical energy.

Internal reflections of light on optical surfaces can degrade the quality of the image formed at the image aperture. The image can be degraded in a myriad of optical phenomenon as a result of internal reflections. One example of degradation is by the formation of multiple images of the object at the image aperture. Another example of degradation caused by internal reflections is the formation of interference fringes at the image aperture. Still another example in which the quality of the image may be degraded is in the loss of contrast or detection limit when reflected light from an optical surface

impinges out of focus at the image aperture and does not contribute to the formation of the image of the object. The object in spectrometers is typically the entrance slit or entrance aperture through which the optical energy to be analyzed enters the spectrometer.

In a concentric spectrometer of the Dyson optical configuration, there are two specular surface reflections that contribute to, or give rise to, internal reflections. Both reflections originate at the convex surface of the plano-convex lens, which lies concentric to a concave diffraction grating. The first reflection occurs when light transmitted from the object plane falls incident on the convex surface of the lens and the second occurs when the diffracted light from the grating impinges on said convex surface. Either one or both of these reflections can degrade the image quality of the spectrometer.

The effects of internal reflections have been reduced in the prior art by the deposition of various antireflection coatings on the optical surfaces within the concentric spectrometer. An antireflective coating(s) may be applied to optical surfaces to reduce the differential change in refractive index when the ray propagates from one optical media (such as air) to a second optical media of different refractive index (such as glass), thus reducing the magnitude of the specular reflection. Many examples of coatings on optical surfaces exist that reduce the magnitude of reflections on optical surfaces. Indeed a great amount of literature has been devoted to the study of single, and multiple layer depositions that reduce reflections on optical surfaces.

A high performance antireflection coating(s), usually a multi-layer dielectric coating that substantially reduces the reflection at a surface, has inherent disadvantages. The disadvantages include a high cost of production, a narrow range of wavelengths for which the reflection loss is low, limited angles of incidence in which rays may propagate with low reflection, and are fragile requiring special handling, cleaning and environmental considerations. Indeed, these high performance coatings can cause a

50661-4

3

greater magnitude of reflection than a surface without an antireflective coating when used beyond the wavelength range of design. Regardless of the coating(s) used the internal reflections are not reduced over a wide wavelength range to a level which degradation of the image quality does not take place by one or more of the aforementioned optical phenomenon within concentric optical systems.

Another means in which internal reflections have been reduced in concentric spectrometers is by the reduction of the numerical aperture (NA) of the spectrometer. One way the NA of the spectrometer can be reduced is by the placement of an optical stop within the spectrometer. This is undesirable since the result is a loss in detectable signal, a decrease in the entendue or throughput of the optical system, and can add to or increase the stray light within the spectrophotometer since more energy must be absorbed within the confines of the spectrometer.

There is a need, therefore, for the mitigation of internally reflected light within a concentric spectrometer such that no degradation of the image quality or loss in contrast occurs yet high entendue is preserved.

Disclosure of Invention

Some embodiments of the present invention overcomes the limitations of internal reflections in concentric spectrometer optics by mitigation of the specular reflected rays from propagating through the optical system. As a result the quality of image at the detection or image plane is preserved while maintaining high entendue.

50661-4

3a

In accordance with one embodiment of the present invention, an object and an image aperture are provided, through which optical radiation, or light, enters the spectrometer through said object aperture and a spatially
5 dispersed image of said object aperture by wavelength is formed at said image aperture. The field or extent of the object and image apertures along with the focal ratio of the optical system defines the limit within which light may

propagate the optical system. Rays that propagate the system at the limit of the aperture fields are the marginal rays.

A concave diffraction grating is provided that reflects and diffracts incident light from an object(s) from the object plane and participates in the formation of a spatially dispersed image of the object(s) by wavelength at the image plane. A plano-convex lens is provided through which light from the object plane is transmitted to the diffraction grating, where the light is diffracted and reflected, then transmitted again through the same plano-convex lens to form a spectrally dispersed image of the object within the image plane. The convex surface of the lens and concave surface of the diffraction grating are concentric, or nearly so, about a common center of curvature. An optical axis is also provided that includes the center of curvature of the optical elements and extends through the mechanical axis of both the lens and diffraction grating. A radial distance is defined from the optical axis that includes both object and image apertures.

Meridional planes, which include the optical axis, are defined to be perpendicular to the x-y path of a given diffracted ray as that ray propagates from the grating towards the convex surface of the lens. A diffracted ray that falls incident on the convex lens surface of the lens will give rise to specular reflection. A ray that falls incident on the convex lens surface prior to intersection of the rays' meridional plane will cause the specular reflection to be directed to impinge on the grating a second time. This ray can further propagate the optical system by means of zero order diffraction to form a spectra or part of a spectra within the image aperture which does not correlate to the spectra of interest. The result is an increase in stray light. A diffracted ray that intersects the rays' meridional plane prior to impinging on the convex lens surface will cause the specular reflection to be directed away from the diffraction grating and image plane without possibility of secondary reflection or diffraction. A baffle or series of baffles and or surfaces containing light absorbing media can be used accordingly to prevent further propagation within the spectrometer without interference with the optical path of the

50661-4

5

spectrometer. At least some embodiments of the present invention exclude the possibility of the diffracted rays from impinging on the surface of the convex lens without prior intersection of the meridional plane, thus eliminating
5 further propagation of internal specular reflections.

Another aspect of the invention is the use of baffles which need only prevent propagation of light from one direction since secondary diffraction or reflection does not occur on the grating surface. The baffles can therefore
10 be optimized to more completely mitigate stray light by multiple impingement of the reflected light on the absorbing media or baffles to further reduce the total stray light within the spectrometer.

Further in accordance with an embodiment of the
15 present invention, marginal rays extending from the object aperture toward the optical axis are not permitted to intersect the optical axis prior to the convex surface of the lens as internal reflections will result. Furthermore, marginal rays that extend away from the optical axis define
20 the clear aperture of the optical system.

Another feature of an embodiment of the present invention is an aperture mask placed in close proximity to the concave surface of the grating. This aperture mask limits the NA of the spectrometer and additionally reduces
25 stray light in the spectrometer. The edge or near periphery of the grating is typically not of optical quality. The edge of a grating is usually chamfered to decrease the frailty of the grating but can have the undesirable effect of scattering light towards image aperture. Also, the
30 optical surface beyond the clear aperture of the grating

50661-4

6

includes defects from the replication or manufacturing processes. Thus an aperture mask provides a surface that is absorbent to light, serves to limit the NA of the spectrometer, and masks that region beyond the clear
5 aperture of the grating to prevent the scattering of light towards the image aperture.

Further in accordance with an embodiment of the current invention, the object and image apertures lie in parallel or coincident plane(s) in close proximity to, or
10 are included within, the planar surface of the plano-convex lens. The thickness of the plano-convex lens and lens radii separation of the convex surface of the lens and concave surface of the diffraction grating, radii of the diffraction grating, and grating groove density are concurrently
15 adjusted to minimize aberrations within the spectrometer apertures and provide the desired spatial dispersion. Furthermore, the radial distance from the optical axis at which the object and image apertures reside and the diameters of the lens, grating, and aperture mask are
20 adjusted in accordance with the invention to provide the desired numerical aperture for the spectrometer while eliminating internal reflections.

According to one particular aspect of the invention, there is provided a concentric spectrometer which
25 mitigates internal specular reflections, said spectrometer having an optical axis and comprising: (a) an object aperture located substantially at a radial distance from said optical axis; (b) an image aperture located substantially at said radial distance from said optical
30 axis; (c) a plurality of optical elements comprising a

50661-4

6a

plurality of non-planar optical surfaces having centers of curvature which are substantially common on said optical axis; wherein said plurality of non-planar optical surfaces includes at least one grating surface which is a aplanatic
5 for zero order of diffraction; wherein said plurality of non-planar optical surfaces includes at least one convex refracting surface; and (d) a plurality of planar optical surfaces substantially coincident with the centers of curvatures of said plurality of optical surfaces and are
10 substantially perpendicular to said optical axis.

Brief Description of Drawings

FIG. 1 is a top plan view (x-z plane) of a known modified concentric spectrograph with object and image apertures not included within the dispersion axis.

15 **FIG. 2** is a side view (y-z plane) of **FIG. 1**.

Fig. 3 is an axial view (x-y plane) of **FIG. 1** looking through the planar surface of the lens toward the diffraction grating.

20 **FIG. 4** is an axial view (x-y plane) of a known modified concentric spectrograph showing two object and image apertures.

FIG. 5 is an alternative arrangement, axial view (x-y plane), of a known modified concentric spectrograph with two object and image apertures.

25 **FIG. 6** is a top plan view (x-z plane) of **FIG. 1** with non-restrictive aperture stop and shown path of internal reflection.

50661-4

6b

FIG. 7 is a top plan view (x-z plane) of **FIG. 6** with aperture stop in position that eliminates internal reflections.

FIG. 8 is a top plan view (x-z plane) of **FIG. 7** with reduced numerical aperture.

FIG. 9 is an axial view (x-y plane) of **FIG. 7** with reduced numerical aperture.

FIG. 10 is a top plan view (x-z plane) of the preferred embodiment of the present invention.

FIG. 11 is a side view (y-z plane) of a preferred embodiment.

FIG. 12 is an axial view (x-y plane) of **FIG. 11** preferred embodiment.

FIG. 13 is a top plan view (x-z plane) of an implementation of the preferred embodiment.

FIG. 14 is a section view of **FIG. 13** showing details of the preferred embodiment of the present invention.

Best Mode for Carrying Out The Invention

Referring to **FIGS. 10-14** there is shown a concentric spectrometer of Dyson optical configuration with mitigation of internal reflections in the preferred embodiment of the present invention. Prior art systems pertaining to spectrometer designs are shown in **FIGS. 1-9**.

Shown in **FIGS. 1 and 2** is a modified concentric spectrometer **200** with shown object aperture **205**, and image aperture **211**. A plano-convex lens **215** with planar surface **216** and convex surface **217** are shown. The diffraction gating **220** with dispersion surface **221** is positioned at a distance along the optical axis **203** such that convex surface **217** of lens **215** are concentric or nearly so. Object aperture **205** is coincident with object plane **202** through which light enters spectrometer **200** where upon light is refracted by lens **215** to substantially fill grating surface **221**. Light is diffracted by grating surface **221** per known grating equation $kn\lambda = \sin\alpha + \sin\beta$, where k is the groove density of the grating, n is the order of diffraction, λ is the wavelength of incident light, α is the angle of incident, and β the angle of diffraction. Diffracted light propagates through lens **215** towards image plane **201** where a spectral image is formed within image aperture **211** where said spectra **206** may be detected as a spatial dispersion of light vs. wavelength in

FIG 3. When the order of diffraction is zero, $n=0$, the angle of incidence is equal to the angle of dispersion and a reflection takes place. For a given dispersion several orders of diffraction are present, positive, negative, and zero. The zero order **210** image of object aperture **205** is shown relative optical axis **203** as reference to the $n=1$ order of diffraction. Meridional plane **225** containing optical axis **203** is defined perpendicular to grating grooves of grating surface **221** and separates object aperture **205** from image aperture **211**. Object aperture **205** is disposed at distance **272** from meridional plane **225** so as to prevent a reentrance of diffracted light by image aperture **211**.

A modified concentric spectrometer **200** has several undesirable qualities which degrade the purity of the spectra and limits the detectable range of the spectrometer due to stray light. The cause of this degradation in performance is due to internal reflections between the convex surface **217** of lens **215** and grating surface **221**. An internal reflection known to contribute to stray light within image aperture **211** is illustrated in **FIG. 6** showing formation and path of reflection. Light to be analyzed enters the spectrometer through object aperture **205** and propagates along ray path **250** to planar surface **216** of lens **215**. The ray proceeds along path **251**, **252** to impinge on grating surface **221**. At grating surface **221** the ray is diffracted by angle vs. wavelength. For a given wavelength ray **260** proceeds to lens surface **217** where a portion of the light is reflected along path **265** and the remaining light is transmitted through lens **215** as ray path **268** towards image aperture **211**. Some of the reflected rays **265** impinge on the grating a second time and are reflected in accordance with a zero order of diffraction per diffraction equation as rays **266**. The zero order rays **266** of the second incidence on diffraction grating surface **221** proceed through lens **215** along ray path **267** to impinge within image aperture **211** creating a second partial image of the primary spectra **206**. This partial spectrum is not spatially correlated to primary spectra **206** and prevents detection of specific wavelengths for which gives a spectrometer utility in the field of atomic absorption spectroscopy. Diffracted rays **260** from grating surface **221** follow a

x-y path towards convex lens surface **217** and impinge on the lens surface **217** within area **250**. For a given x-y ray path a meridional plane, a plane of reflection **236**, is defined to include optical axis **203** and be perpendicular to x-y line of propagation shown in **FIG. 3**. Specular reflections contribute to unwanted partial spectral images when the plane of reflection **236** dissects surface area **250** of convex lens surface **217**, identified as area **251** in **FIG. 3**.

A modified concentric spectrometer of known prior art, Dyson configuration, may include more than one object and image aperture as shown in **FIGS. 4-5**. Light enters the spectrometer through object aperture **405(505)** and **475(575)**, transmitted through lens **415(515)** towards concave grating surface **421(521)** of grating **420(520)**. Image apertures **411** and **481** are located on the same side of meridional plane **425** through which primary spectra **406** and **476** of object aperture **405** and **475** are imaged. Image apertures **511** and **581** are on different sides of meridional plane **525** through which primary spectra **506** and **576** of object aperture **505** and **575** are imaged. Zero order images of object apertures **405(505)** and **475(575)** are shown relative to the optical axis as **410(510)** and **480(580)** respectfully. The axis of dispersion **435** and **445** for spectra **406** and **476** may be coincident so as to make possible that both spectra be incident on a single detector. The dispersion axis **535** of spectra **506** and dispersion axis **545** of spectra **576** are disposed on different sides of meridional plane **525** to provide greater separation of the two spectra so as to provide additional space independent detection means. Regardless of the number of object or image planes or spatial arrangement, internal reflections can occur if surface areas **450(550)**, **460(560)** of lens **415(515)** are dissected by planes of reflection **436(536)**, **446(546)** respectfully. Specular reflections from convex lens surface within sections **451(551)** and **461(561)** contribute to the formation of unwanted partial spectral images degrading the performance of the spectrometer. Another disadvantage of the prior art dual arrangements is the object apertures **405(505)** and **475(575)** are placed at a different distance from the optical axis

403 than the image apertures **411(511)** and **481(581)**. The nonsymmetrical arrangement of apertures about the optical axis **403** degrades image quality of spectra **406(506)** and **476(576)**.

Aperture stops have long been used in as a means of controlling aberration and limiting the NA of optical systems. An example of an aperture stop **290** used in prior art modified concentric spectrometer is shown in **FIG. 3** and **FIG. 6**. The aperture stop **290** in **FIG. 6** limits the NA of the spectrometer but does not prevent internal reflections from impinging on grating **220** and resulting in subsequent degradation in quality of primary spectra **206** of **FIG. 3**. The size of the aperture stop **390** of **FIG. 7** through which light is permitted to pass can be decreased in a modified concentric spectrometer to prevent internal reflections from the convex surface **317** of lens **315** from impinging on grating surface **321** of grating **320**. Light enters the modified spectrometer through object aperture **305** of object plane **302** along ray path **350**. Ray path **350** is transmitted through the planar surface **316** lens **315** along ray path **351** to convex lens surface **317**. Light is refracted by lens **315** and impinges on concave grating surface **321** where the said light is diffracted towards lens surface **317**. A significant portion of the usable light **353** that would contribute to the formation of the primary spectra **306** within image aperture **311** is prevented from doing so by aperture stop **390**. The result of this obscuration creates a situation by which the gain of the detection means must be increased to account for the decrease in intensity of the spectra. Obscuring entrant polychromatic light within a spectrometer also increases the amount of stray light generated by scattering of light off of aperture stop **390**. This results in an undesirable decrease in contrast or increase in the signal to noise ratio, thus limiting the detection range even though the reflection **365** has been eliminated by aperture stop **390**. The reduced NA of the spectrometer is best illustrated in **FIG. 8** and **FIG. 9**. The grating **320** is obscured by aperture stop **390** permitting light to impinge on grating surface **321** within the opening aperture stop **390**. Diffracted light impinges on the lens surface **317**

in area **350** all on side of reflection plane **336** that does not contribute to internal reflections at the expense of a significant reduction in etendue as compared to same area **250** of **FIG. 3**.

The problems of modified concentric spectrometers (i.e., stray light due to internal reflections, stray light due to obscuration of entrant light, stray light due to defects of the grating surface beyond the clear aperture, partial non-correlated spectra, diminished etendue) have been solved in this invention in a concentric spectrometer that mitigates internal specular reflections. Light enters a specular mitigating concentric spectrometer **100** through object aperture **105** of object plane **102** of **FIG. 10** and **FIG. 11**. Within the object aperture **105** may be disposed a plurality of entrant ray paths each of which can be dispersed to form individual spectra of each polychromatic entrant ray path within image aperture **111** of image plane **101**. In accordance with the present invention, object plane **102** and image plane **101** need not lie in coincident space and may be displaced from planar surface **116** of plano-convex lens **115**. In further accordance with the present invention a Dyson optical configuration including a convex surface **117** of lens **115** and concave surface **121** of diffraction grating **120** are separated along optical axis **103** at a distance which minimized third order aberrations. An aperture mask **190** is introduced close to or included on concave surface **121** of grating **120**. The aperture mask **190** limits the NA of the spectrometer to that which is greater than NA of the entrant rays. So conceived aperture mask **190** impedes the propagation of stray polychromatic entrant rays towards object or image planes **101** and **102** respectfully by means of absorption. Additionally aperture mask **190** prevents said stray polychromatic entrant rays from impinging on concave grating surface **121** beyond the clear aperture of grating **120** where surface defects and edge chamfer reside thus preventing propagation or generation of stray light. Still another aspect of aperture mask **190** is to prevent specular reflected rays **165** of impinging rays **160** on convex surface **117** from propagating toward object and image planes **101** and **102** respectfully.

Object aperture **105** and image aperture **111** are placed at radial distance **137** from optical axis **103** shown in **FIG. 12** along which the image quality is optimized. There is therefore a desire to maximize the cord length of radii **137** that intersects image aperture **111** to provide the highest quality of image within image aperture **111**. For a given entrant ray path within object aperture **105** the dispersion axis **135** intersects radii **137** of high image quality. By symmetry zero order image **110** of object aperture **105** also falls incident at radial distance **137** from optical axis **103**. Therefore, per this invention zero order image **110**, object and image aperture **105** and **111** are all substantially at same radial distance **137** from optic axis **103**. A unique aspect of this geometry provides a means for polychromatic entrant rays of object aperture **105** to be reflected off the internal concave surface **117** of lens **115** and directed away from image aperture **111** as reflected rays **166** of **FIG 10**. The result of this geometry is a reduction in stray light impinging on image aperture **111**. The radial distance of **137** and diameter of lens **115** are selected so as marginal rays originating from object aperture **105** do not intersect optical axis **103** but can propagate through the convex surface **117**. This dictates a minimum diameter for radial distance **137** at substantially half that of the diameter of lens **115**. Furthermore, the marginal rays determine the required clear aperture of grating **120** and subsequently the inside diameter of aperture mask **190**. Judicial selection of optical parameters, by those skilled in the art, must be made therefore to obtain a desired spectral and spatial dispersion of light and operating numerical aperture. The optical parameters include and but are not limited to the materials, dimensions, and radii of the optical components as well as groove density of grating **120** spatial location of components per the context of this disclosure. Optical parameters so selected provide a concentric spectrometer that eliminates specular reflected rays **165** from propagating the optical system of a specular mitigating concentric spectrometer **100** as disclosed in **FIG. 10** and **FIG. 11**.

One implementation of the preferred embodiment of present invention is shown in **FIG. 13** and **FIG. 14**. External view **FIG. 13** shows light entering spectrometer **100** through optical fiber **118** of integral fiber optic assemble which includes fiber connector **158** and strain relief **159**. Optical fiber **118** is attached to fiber connector **158** by epoxy adhesive **119**. Fiber connector **158** is located by fiber collet **157** and held in place by clamp **191** using screw **192**. Spectrometer body **150** provides a means to mount and align optical components and maintain said alignment over a wide operating temperature range. Metering rods **153** are threaded into body **150** and secured at one end by locking nuts **154**. The other end of metering rods **153** pass through a flange in spectrometer body **150** to which adjustment nuts **155** are secured. Slots **152** permit one end of the spectrometer body **150**, preferentially the grating end of the spectrometer, to flex in three degrees of freedom; pitch about the x-axis, yaw about the y-axis, and translation along the z-axis. This provides means to position the grating **120** relative to the all other fixed elements of the embodiment achieving x-y positioning and focus of the spectral image **106** within the image aperture **111**. Slots **152** provide additional utility as a thermal expansion joint in spectrometer body **150**. Metering rods **153** of sufficiently low coefficient of thermal expansion CTE, such as Invar, maintain the relative position of the lens **115** to grating surface **121** while allowing body **150** to change linear dimension over temperature at slots **152**. By proper selection of the affixation points of the metering rods **153** to the spectrometer body **150** by those skilled in the art, changes in focus are sufficiently eliminated over a wide operating temperature range. Slots **151** in spectrometer body **150** are used in conjunction with grating retaining ring **193** of **FIG. 14** to place a controlled load on grating **120** and permit rotational alignment of said grating **120** while maintaining contact with spectrometer body **150**. Flexure **151** also assures that the contact between grating **120** and body **150** will be maintained over the operating temperature range of the spectrometer. One feature of the preferred embodiment is that all alignment adjustments are accessible from one end of the

spectrometer making possible in situ alignment of the spectrometer. Plano-convex lens **115** is held in spectrometer body **150** by housing **156**. Circuit board **195** locates detector **112** relative to fiber collet **157** and provides a means to supply power to and extract signal from detector **112**. Object aperture **105** preferentially takes the form of an optical slit formed by an opaque metal deposition, such as nickel, on optically transparent substrate, such as SCHOTT GLASS TECHNOLOGIES B270 glass, **104** to which optical fiber **118** is abutted. Substrate **104** is attached to end of fiber collet **157** so as to maintain alignment of fiber connector **158** with optical fiber **118** to optical slit **105**. Circuit board **195** with attached detector **112** and fiber collet **157** with slit **105** are held against planar surface of lens **115** by means of retaining ring **194**. Optical cement **107** of index of refraction nearly equal to that of the substrate **104**, detector window of detector **112** and plano-convex lens **115** bonds detector **112** and substrate **104** to lens **115** providing mechanical stability without loss due to specular surface reflections at these optical interfaces. Optical cement **107**, such as EPOXY TECHNOLOGIES EPO-TEK 301-2, or others having the desired optical and physical properties can be used. Surface reflections between optical fiber **118** and substrate **104** are similarly eliminated by use of said same optical cement located at **108**. The baffle structure **180** is comprised of a series of individual baffles such as baffle **181** made of or coated with a light absorbent material and may include aperture mask **190** as an integral part thereof. The spacing between individual baffles and the aperture of each baffle or both may be adjusted such that stray light or light which has been reflected from convex lens surface **117** impinges first on a baffle such as **181** then on baffle wall **182**. A baffle structure so deployed provides no less than two opportunities for the absorption of stray light, effectively doubling the absorptivity of the material or absorbing media of baffle structure **180**. Baffle structure **180** is loosely fit into spectrometer body **150** and held in place by an elastic adhesive such as silicone adhesive **196**. The silicone adhesive **196** permits baffle structure **180** to deflect internal to spectrometer body **150** when adjustments are made in

pitch and yaw of grating **120** by means adjustment nuts **155** without becoming detached from body **150**. Baffle structure **180** also prevents ambient light from entering the spectrometer body **150** through slots **152** in body **150** by blocking the light path created by slots **152**.

It will be apparent to those skilled in the art that the optical axis may be altered by the introduction of plane reflecting surfaces, such as fold mirrors or prisms, along the optical path to obtain a desired spatial orientation of components. Regardless of the angle or number of reflecting surfaces it can be shown that when the optical axis is rendered as a straight line, as an optical tunnel diagram, the rays path through the spectrometer relative to the optical axis remains unchanged and is within the scope of this invention.

A concentric spectrometer that mitigates internal specular reflection is thus realized providing high quality spectral images not limited by optical phenomenon created by the reflection of light by internal optical surfaces. The detailed embodiments disclosed herein may be accomplished in a variety of forms without departing from the scope or intent of this invention by those skilled in the art and is not limited to the disclosed embodiments but should be defined by the claims which follow.

50661-4

16

CLAIMS:

1. A concentric spectrometer which mitigates internal specular reflections, said spectrometer having an optical axis and comprising:

5 (a) an object aperture located substantially at a radial distance from said optical axis;

(b) an image aperture located substantially at said radial distance from said optical axis;

(c) a plurality of optical elements comprising a
10 plurality of non-planar optical surfaces having centers of curvature which are substantially common on said optical axis; wherein said plurality of non-planar optical surfaces includes at least one grating surface which is aplanatic for zero order of diffraction; wherein said plurality of non-
15 planar optical surfaces includes at least one convex refracting surface; and

(d) a plurality of planar optical surfaces substantially coincident with the centers of curvatures of said plurality of optical surfaces and are substantially
20 perpendicular to said optical axis.

2. The spectrometer of claim 1 further comprising an aperture mask positioned at said grating surface.

3. The spectrometer of claim 1 further comprising a plurality of light absorbing baffles between said refracting
25 surface and said grating surface.

4. The spectrometer of claim 1 further comprising at least one planar reflecting optical surface positioned in

50661-4

16a

the ray path at an oblique angle relative to said optical axis.

5. The spectrometer of claim 1 wherein at least one of said surfaces is substantially coincident with said object aperture.

6. The spectrometer of claim 1 wherein at least one of said planar optical surfaces is substantially coincident with said image aperture.
7. The spectrometer of claim 1 wherein said object aperture includes one or more apertures through which polychromatic light enters said spectrometer.
8. The spectrometer of claim 1 wherein images of said object aperture are formed within said image aperture spatially dispersed by wavelength along the axis of dispersion substantially perpendicular to the grooves of said grating surface.
9. The spectrometer of claim 1 wherein one said planar optical surface and one said non-planar optical surface form a plano-convex lens of index of refraction higher than of that media that separates the convex surface of the lens and said grating surface.
10. The spectrometer of claim 9 wherein the convex lens surface of said plano-convex lens and said grating surface are spatially separated along said optical axis to advantage of best image formation of diffracted object within said image aperture at said radial distance from said optical axis.
11. The spectrometer of claim 9 wherein said planar surface of said plano-convex lens may include either object aperture or image aperture or both.
12. The spectrometer of claim 1 wherein the radii of said radial distance is sufficient to cause light diffracted from said grating surface to reflect from specular surface of said refracting surface to exclude impingement on said grating surface.
13. The spectrometer of claim 12 wherein said radial distance substantially includes said object aperture and said image aperture and zero order of diffraction.
14. The spectrometer of claim 2 wherein said aperture mask prevents the propagation of light beyond the clear aperture of said grating surface.

15. The spectrometer of claim 7 further comprising an aperture mask for preventing the propagation of diffracted light reflected from the specular surface of said convex surface of said plano-convex lens.

16. The spectrometer of claim 14 wherein said aperture mask does not impede the propagation light that would contribute to the formation of spectra at said image aperture.

17. The spectrometer of claim 1 wherein the non-planar optical surfaces are substantially spherical.

18. The spectrometer of claim 3 wherein said light absorbing baffles absorb light which does not contribute to the formation of spectra by impingement on said baffles no less than two times.

19. The spectrometer of claim 10 further comprising light absorbing baffles which absorb diffracted light reflected from the specular surface of said convex surface of plano-convex lens.

20. The spectrometer of claim 19 wherein said light absorbing baffles absorb light beyond the clear aperture of said grating surface.

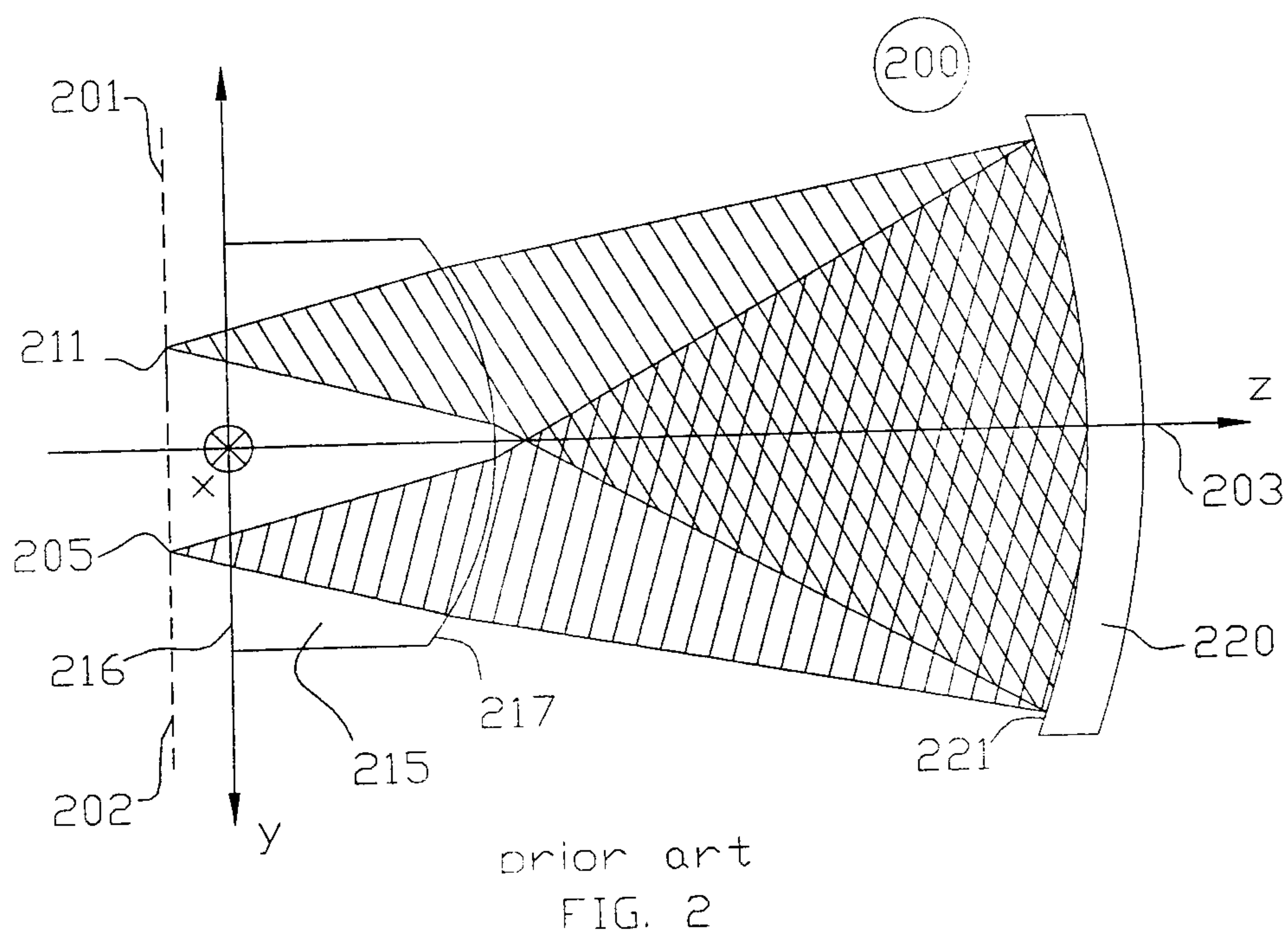
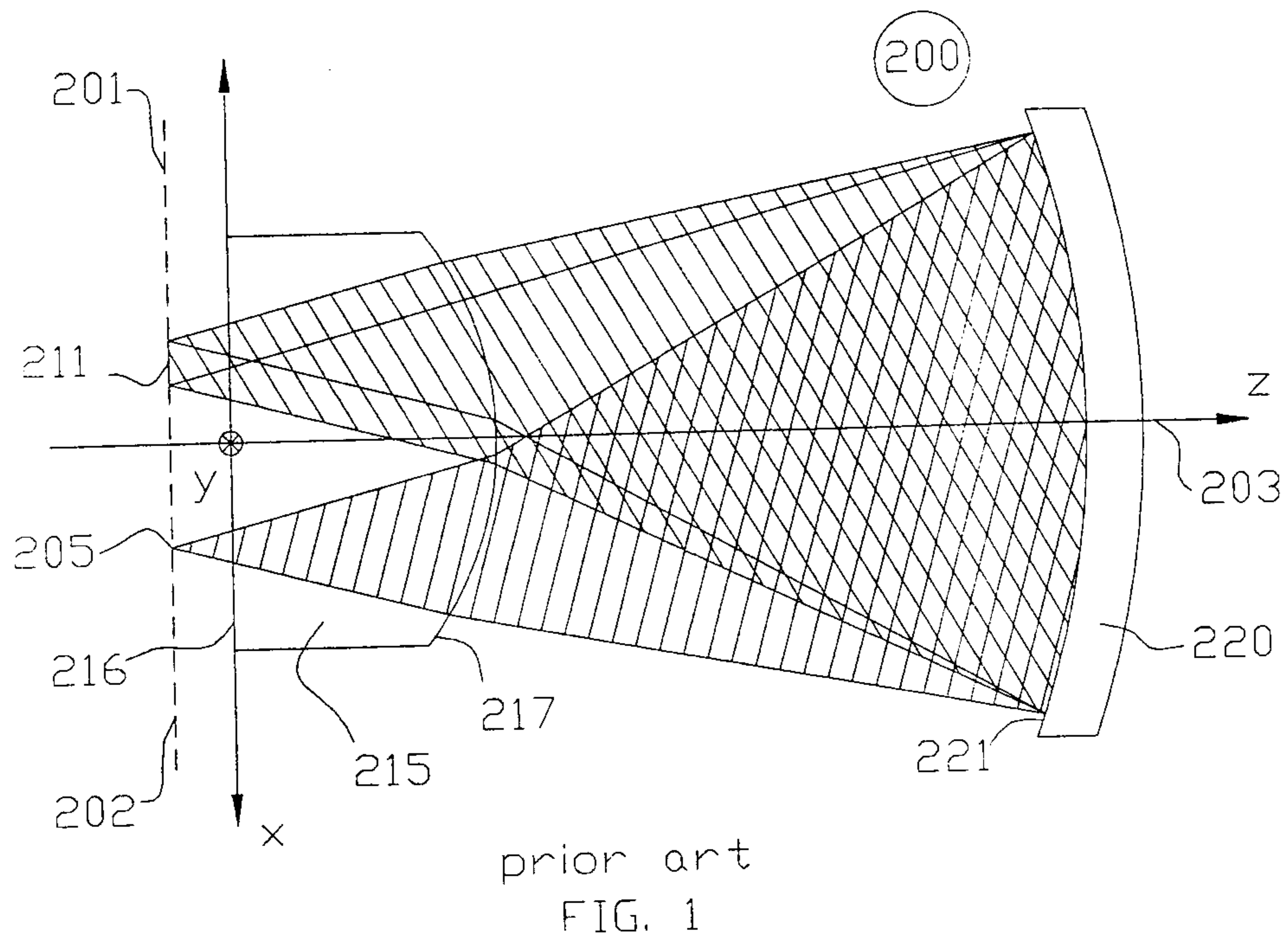

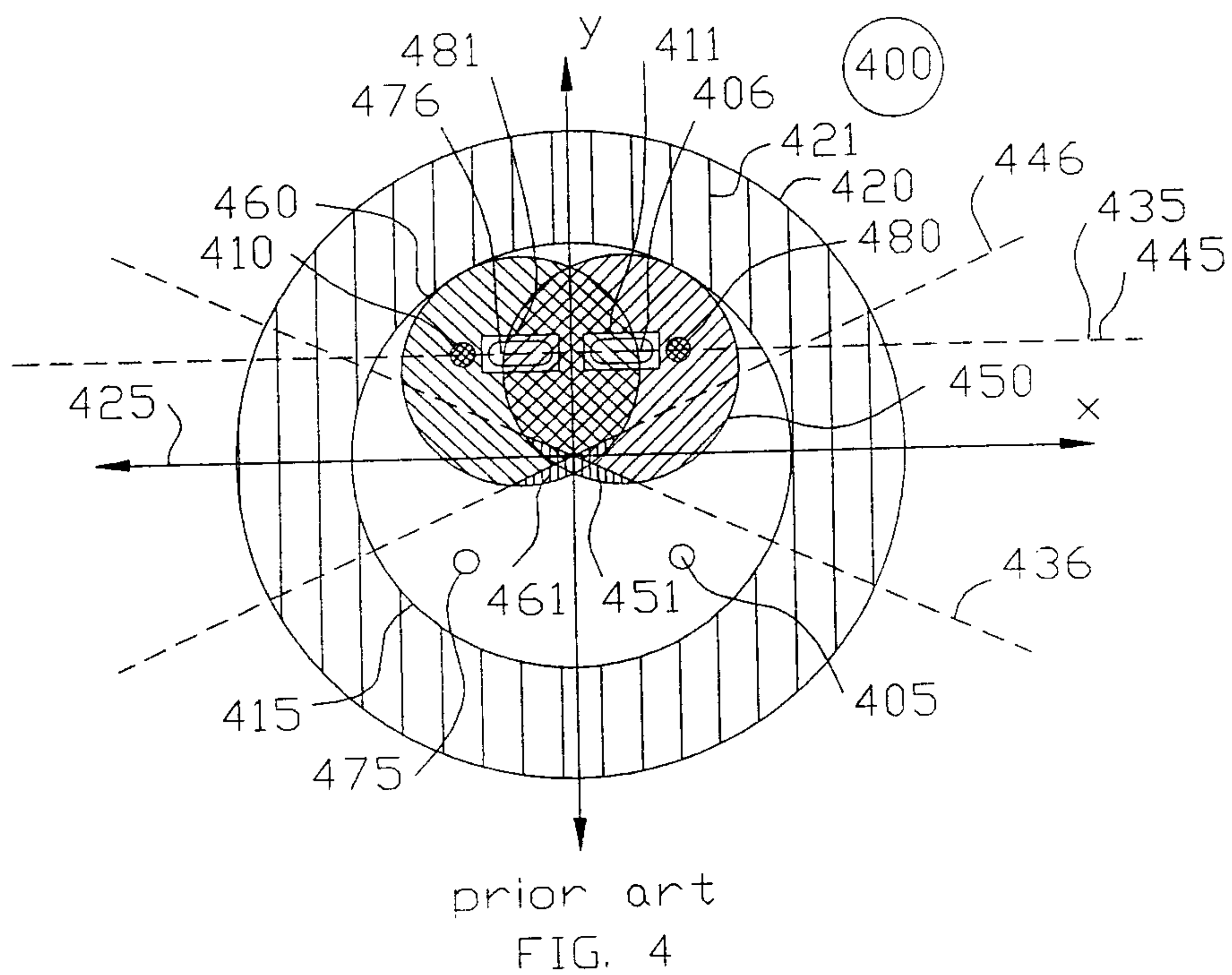
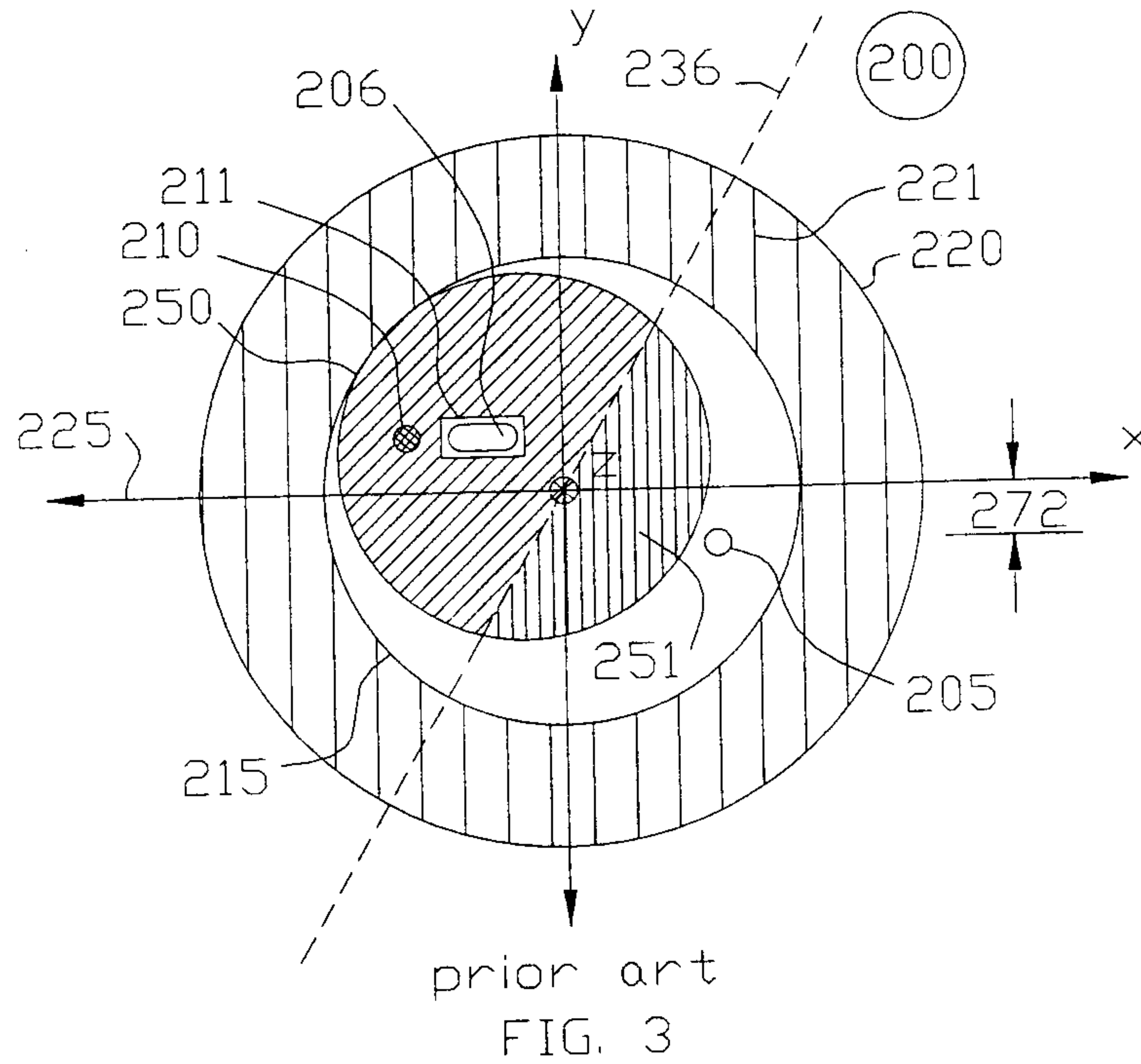

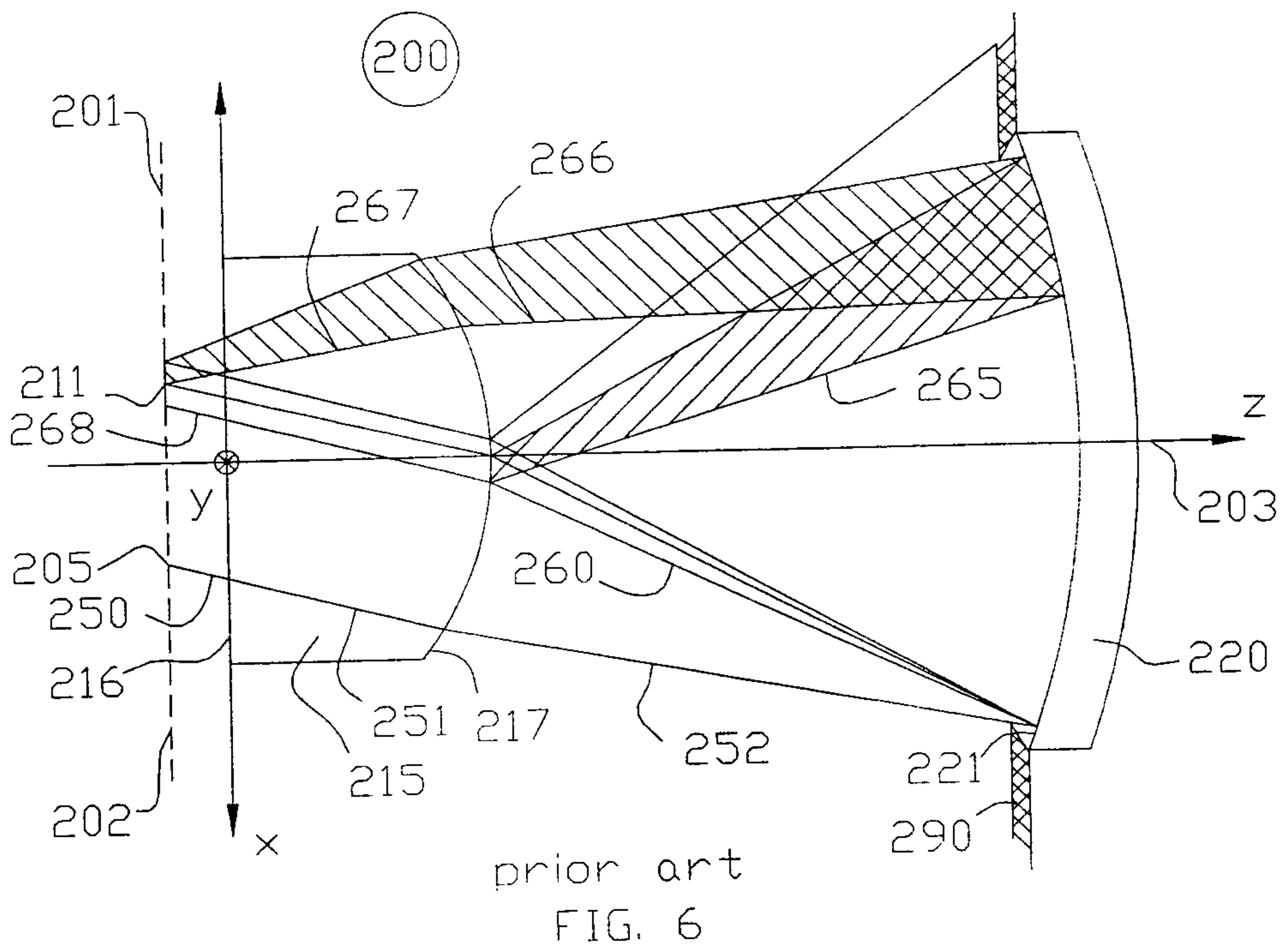
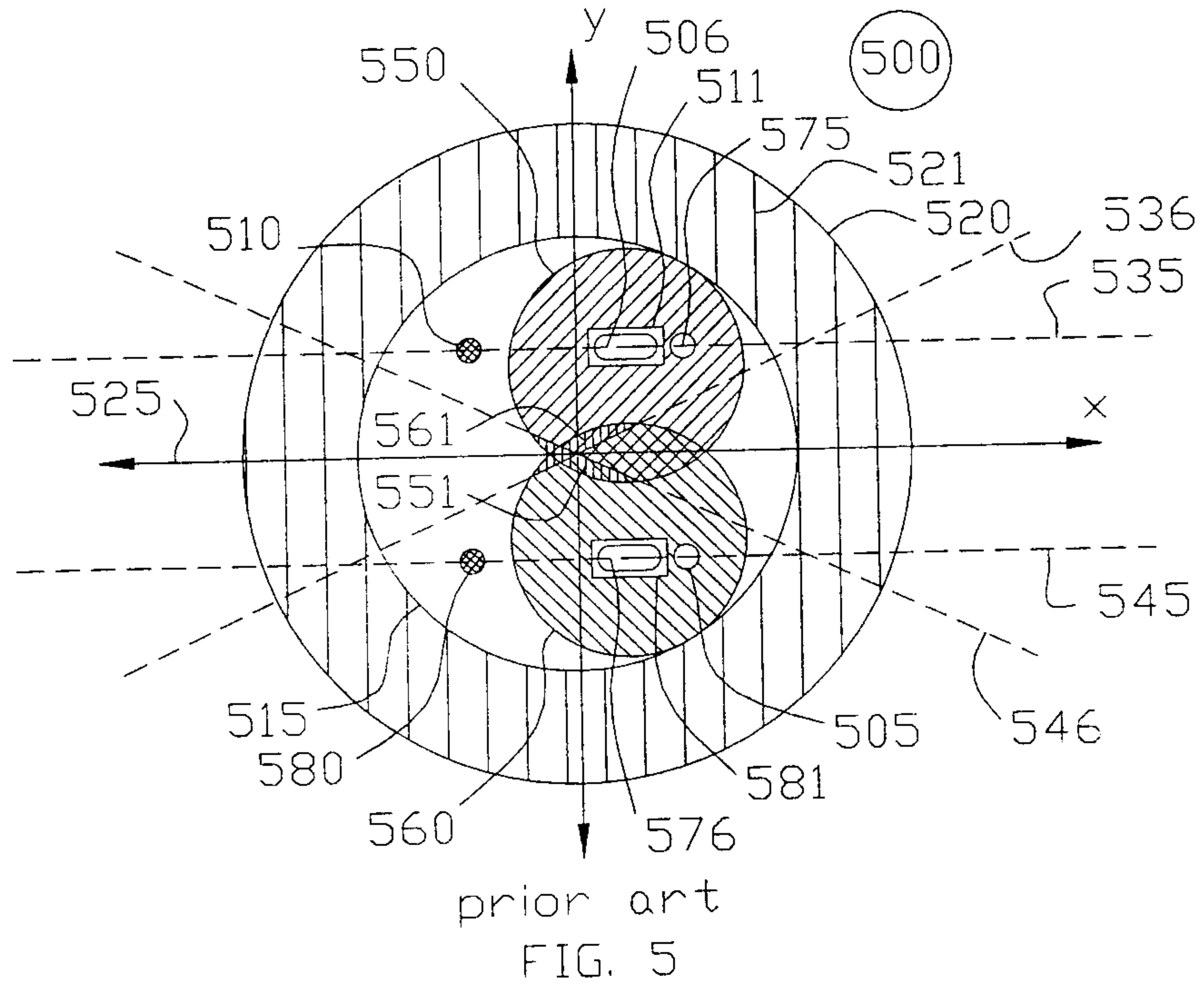

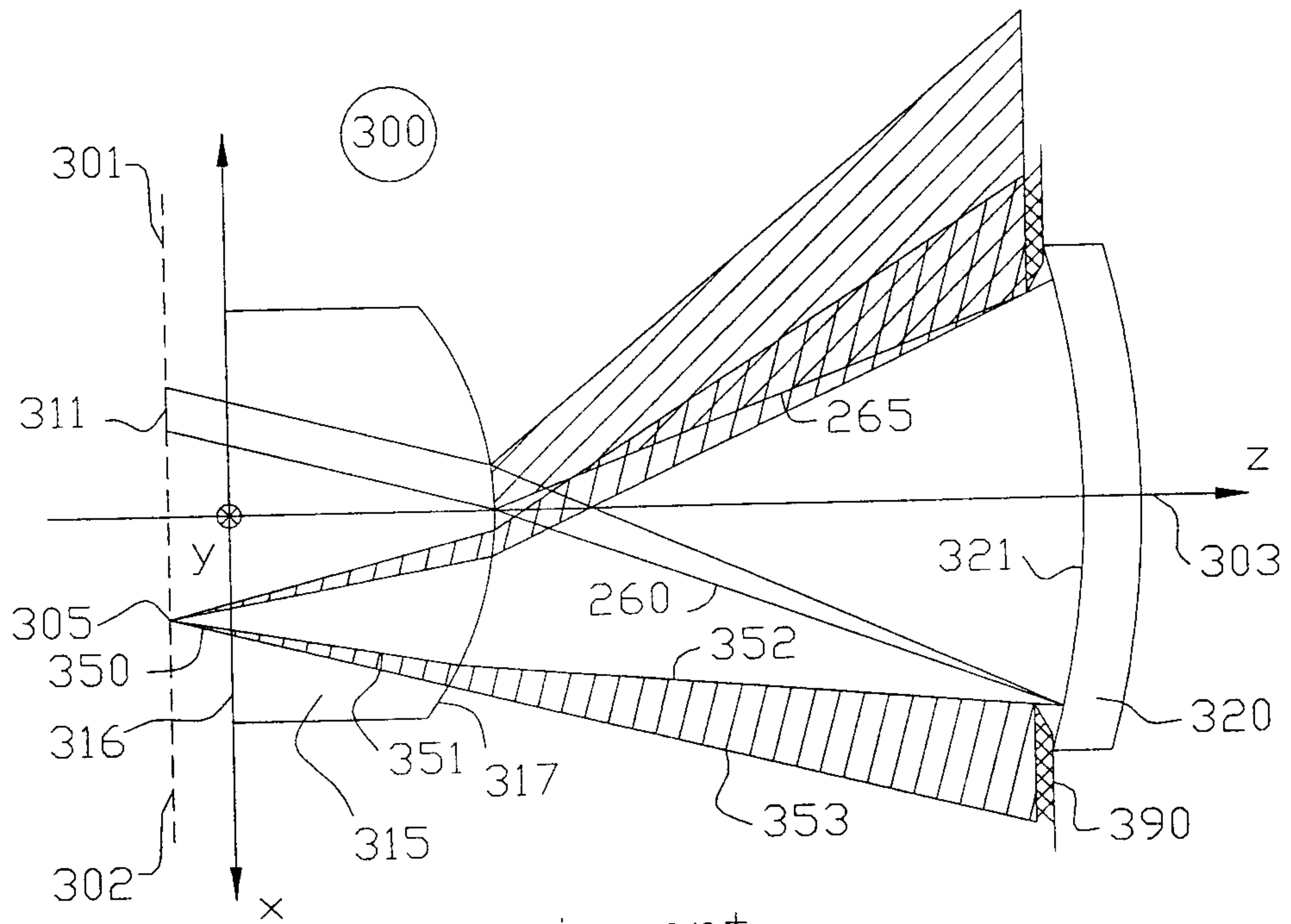

prior art
FIG. 7

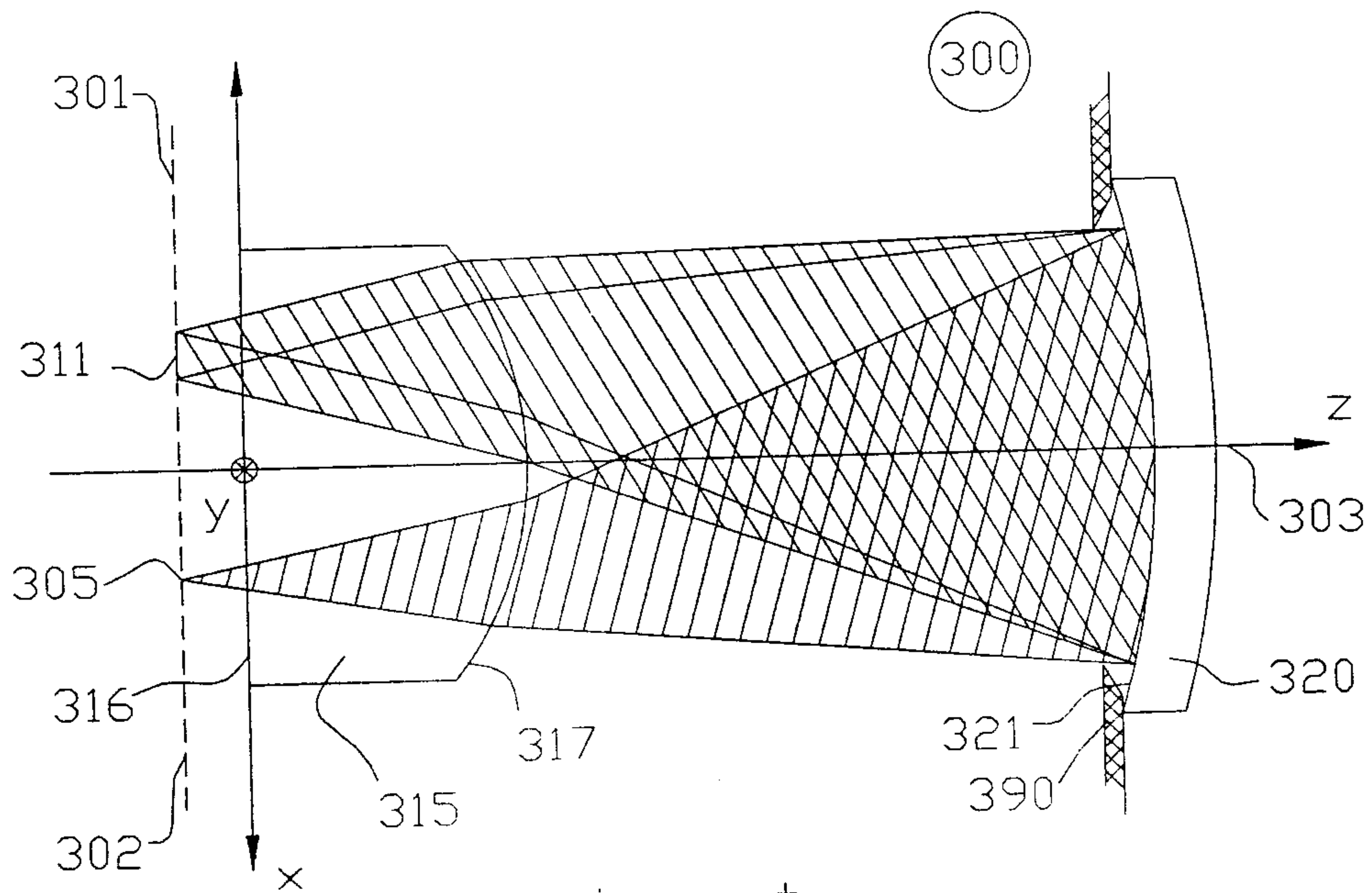

prior art
FIG. 8

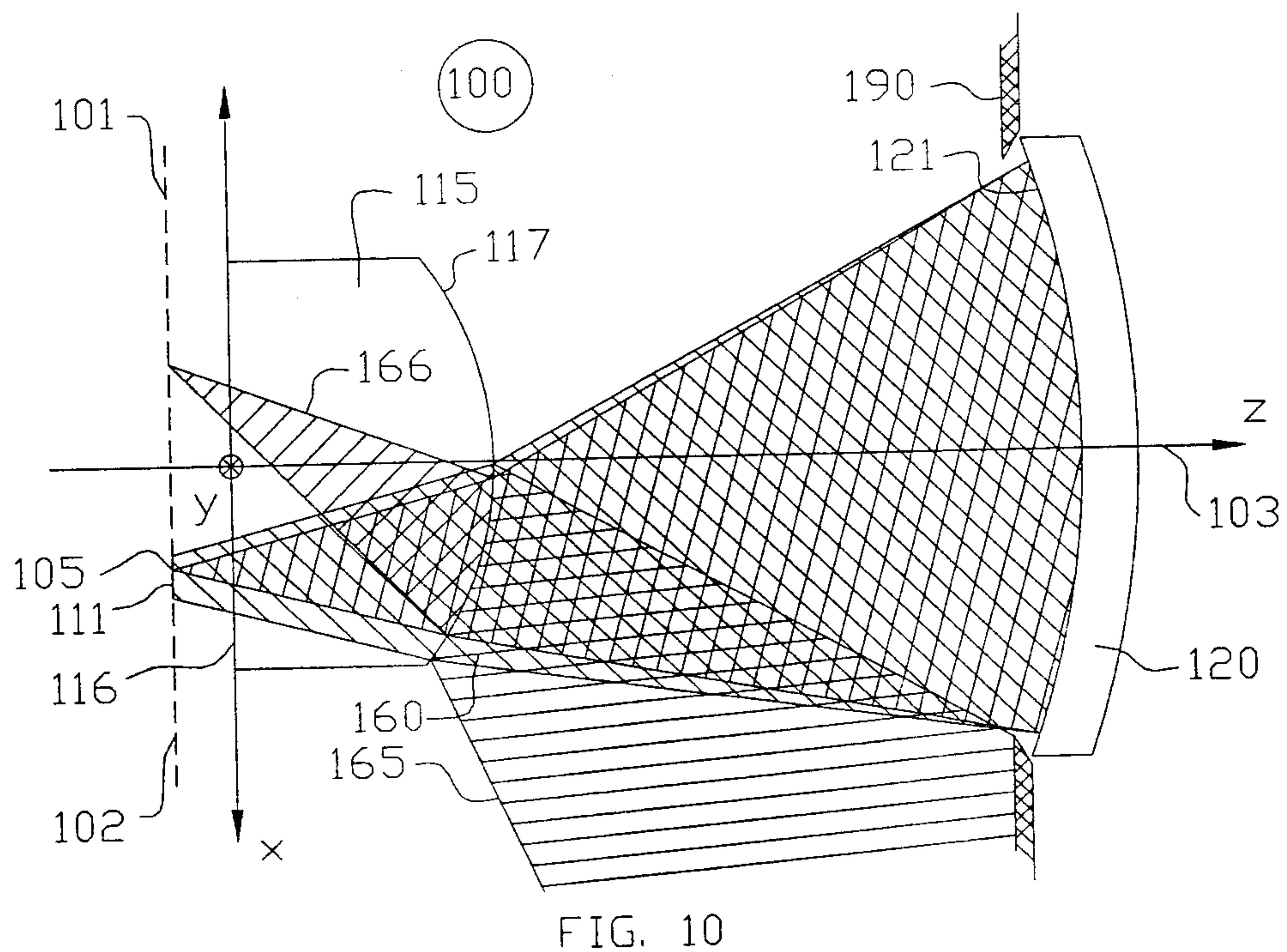
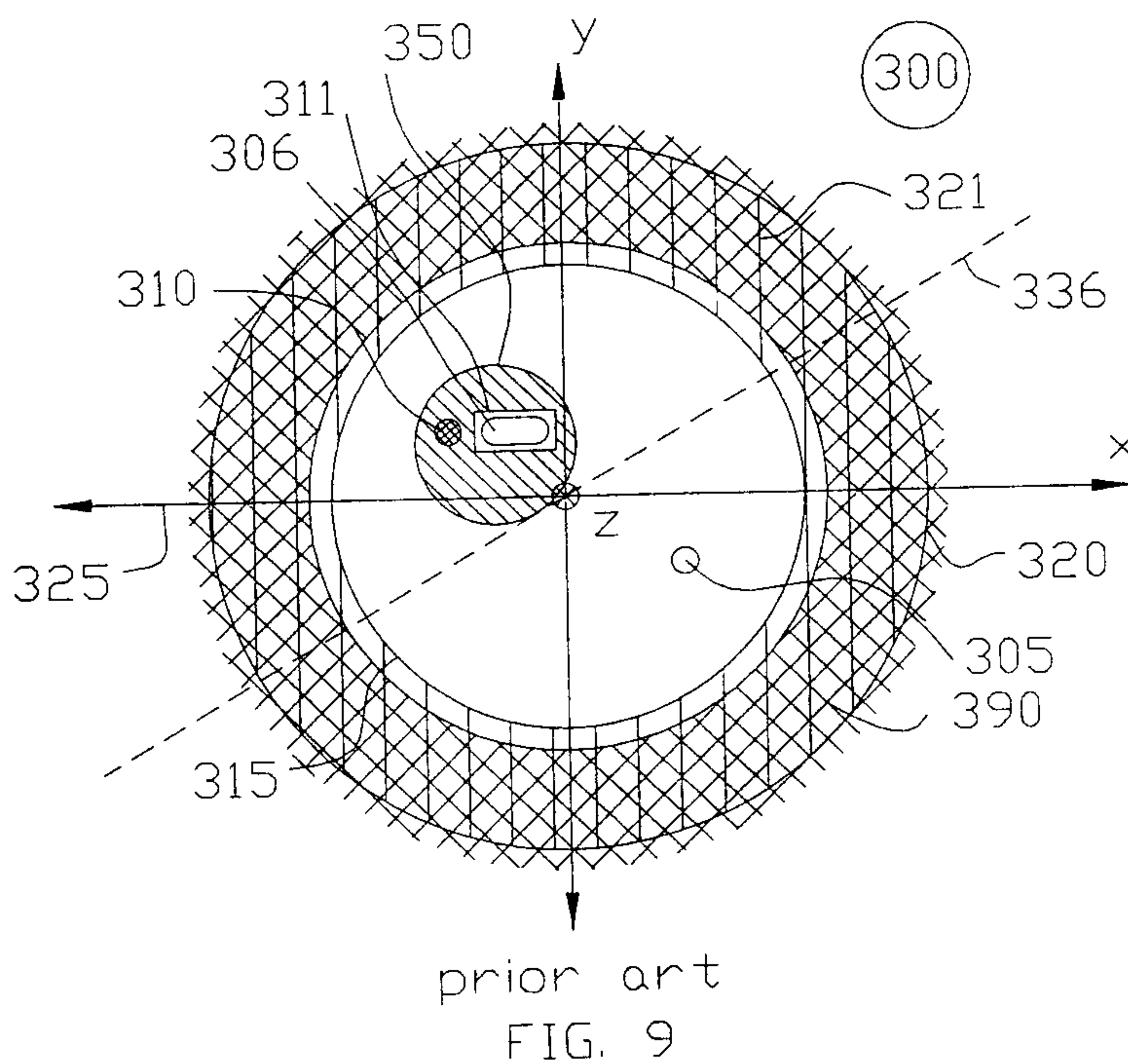

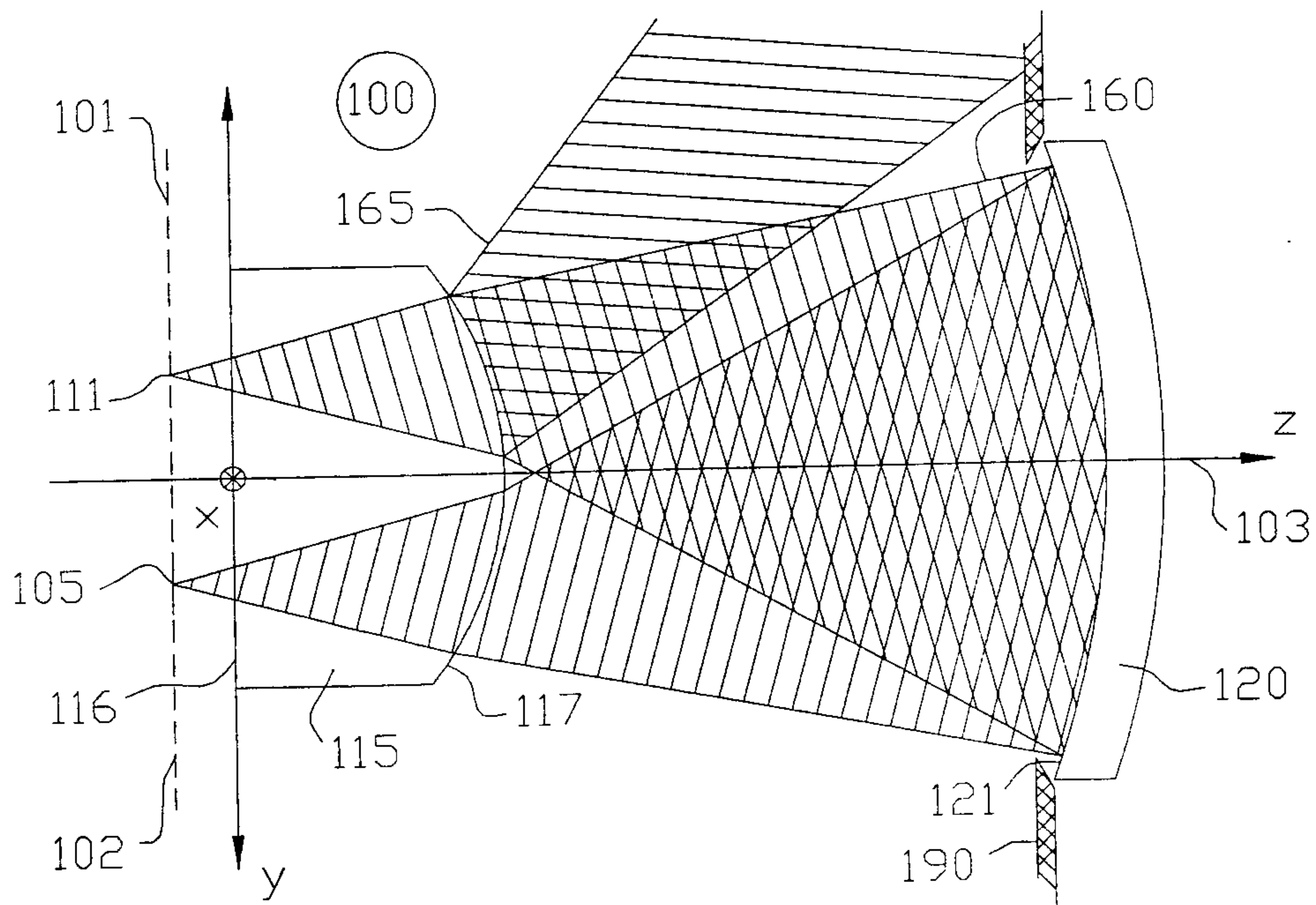

FIG. 11

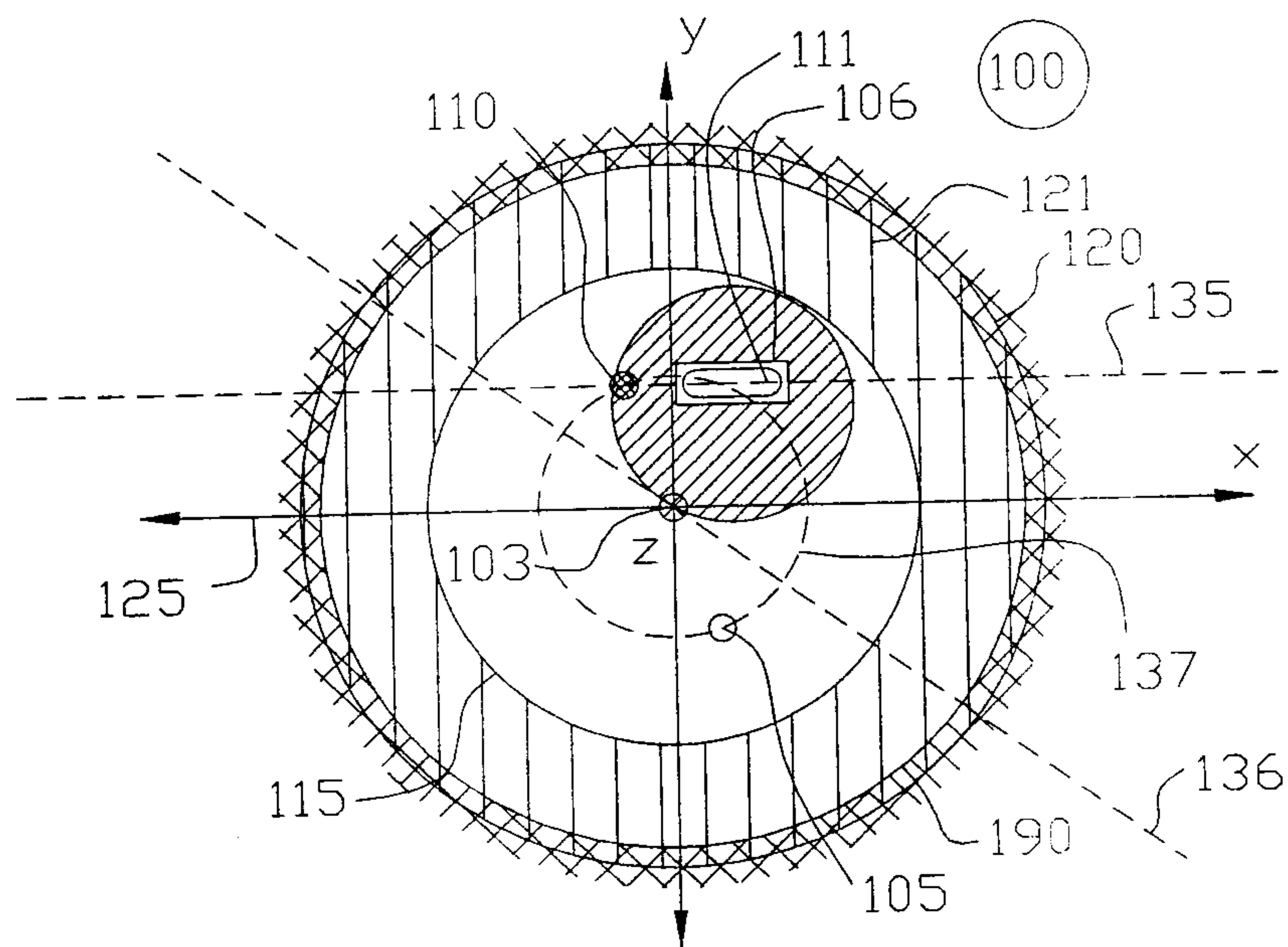

FIG. 12

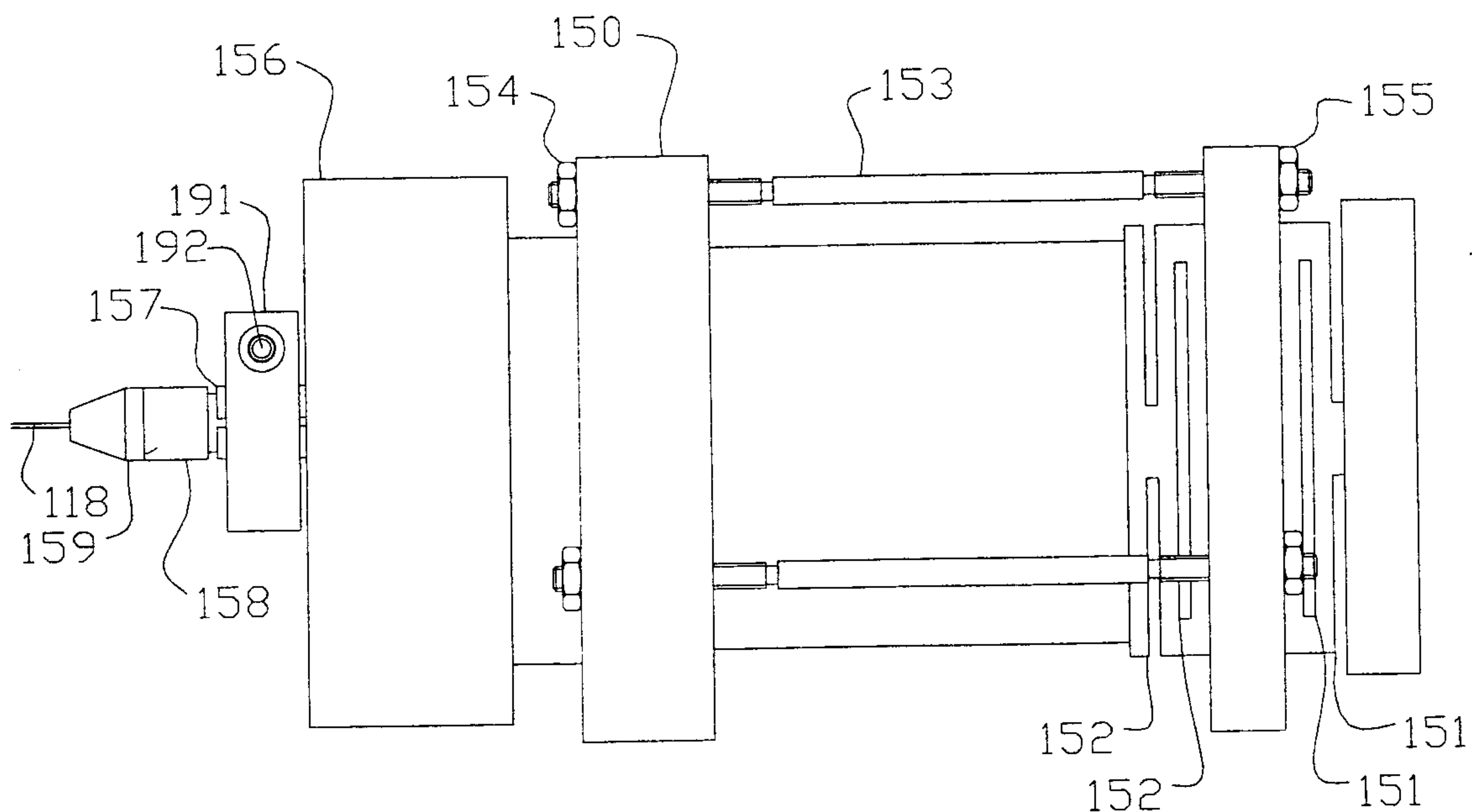

FIG. 13

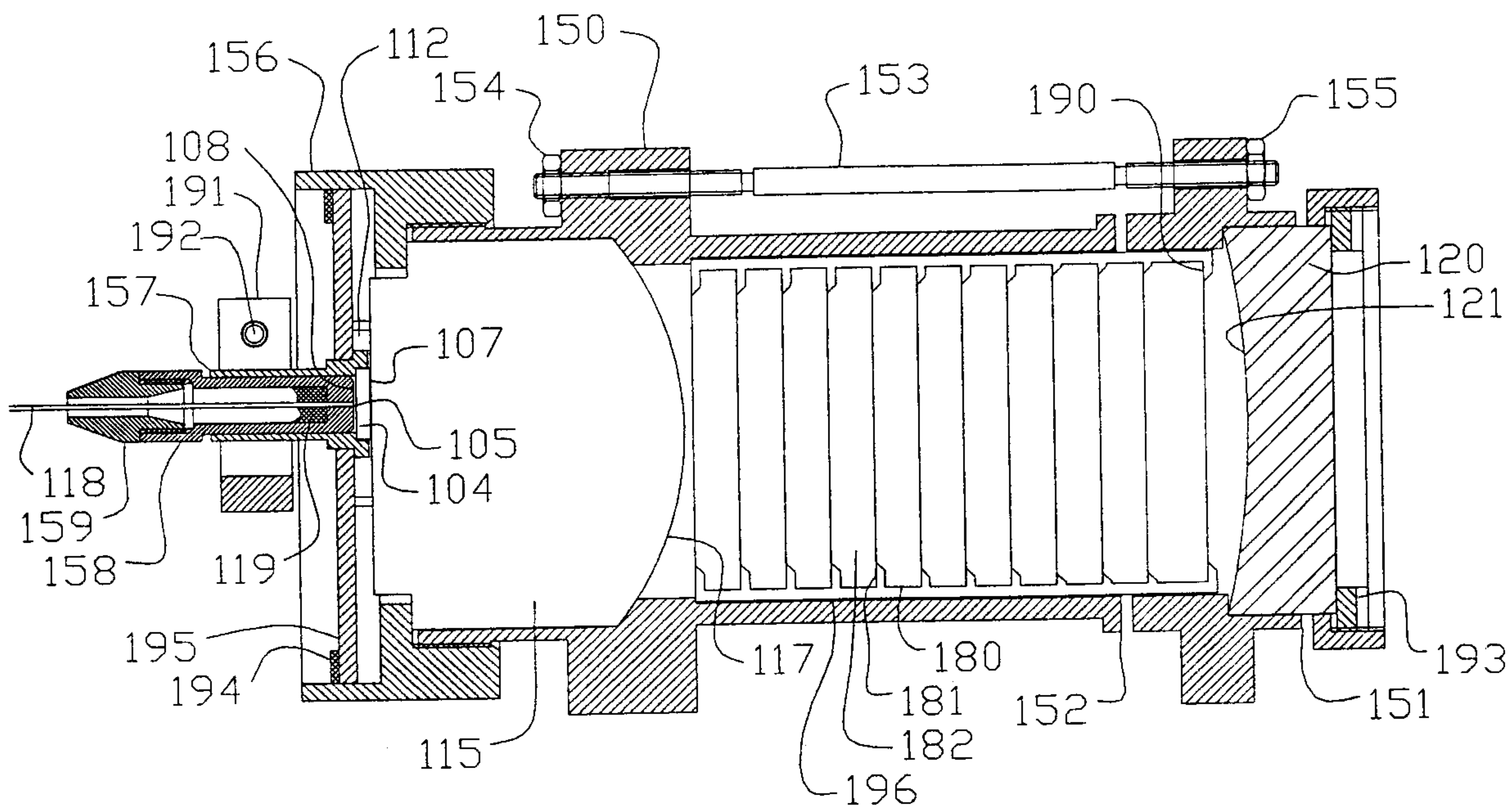

FIG. 14

