

⑫ **EUROPEAN PATENT SPECIFICATION**

- ④⑤ Date of publication of patent specification: **18.05.88**      ⑤① Int. Cl.<sup>4</sup>: **G 01 N 1/02, B 01 L 3/02**
- ②① Application number: **83901609.4**
- ②② Date of filing: **19.05.83**
- ②③ International application number:  
**PCT/HU83/00025**
- ②⑦ International publication number:  
**WO 83/04015 24.11.83 Gazette 83/27**

⑤④ **METHOD AND APPARATUS FOR DISPENSING, PIPETTING AND DILUTING FLUIDS.**

- |  |   |
|--|---|
| <p>③⑩ Priority: <b>19.05.82 HU 159082</b></p> <p>④③ Date of publication of application:<br/><b>30.05.84 Bulletin 84/22</b></p> <p>④⑤ Publication of the grant of the patent:<br/><b>18.05.88 Bulletin 88/20</b></p> <p>③④ Designated Contracting States:<br/><b>CH DE FR GB LI</b></p> <p>⑤③ References cited:<br/><b>US-A-3 419 358</b><br/><b>US-A-3 900 289</b><br/><b>US-A-3 982 667</b></p> | <p>⑦⑧ Proprietor: <b>"LABOR" MŰSZERIPARI MŰVEK</b><br/><b>Rudas László ut.44</b><br/><b>H-2501 Esztergom (HU)</b></p> <p>⑦② Inventor: <b>BALAS, Gizella</b><br/><b>Traktor u. 8</b><br/><b>H-1195 Budapest (HU)</b><br/>Inventor: <b>CSIKOS, János</b><br/><b>Nap u. 29</b><br/><b>H-1082 Budapest (HU)</b><br/>Inventor: <b>KEMENY, Gábor</b><br/><b>Erdi u. 10/a</b><br/><b>H-1112 Budapest (HU)</b><br/>Inventor: <b>SZABO, Zsolt</b><br/><b>Egressy u. 111/a</b><br/><b>H-1149 Budapest (HU)</b><br/>Inventor: <b>VADASZ, Ferenc</b><br/><b>Szakasits Arpád u. 32/b</b><br/><b>H-1119 Budapest (HU)</b></p> <p>⑦① Representative: <b>Lehn, Werner, Dipl.-Ing. et al</b><br/><b>Hoffmann, Eitle &amp; Partner Patentanwälte</b><br/><b>Arabellastrasse 4</b><br/><b>D-8000 München 81 (DE)</b></p> |
|--|---|

Note: Within nine months from the publication of the mention of the grant of the European patent, any person may give notice to the European Patent Office of opposition to the European patent granted. Notice of opposition shall be filed in a written reasoned statement. It shall not be deemed to have been filed until the opposition fee has been paid. (Art. 99(1) European patent convention).

## Description

The invention relates to a method for dispensing, pipetting and consecutively diluting fluids, primarily for analytical laboratory use, wherein a constant stream of the fluid is established and maintained in a part of a tube by means of a pump and a predetermined amount of the fluid is dispensed by opening valve means in said tube on the pressure side of the pump. Furthermore, the invention relates to an apparatus for dispensing and pipetting fluids comprising a pump and controlled valve means in a tube on the pressure side of the pump.

The commercially available numerous automatic laboratory diluter-dispensers utilize almost in all cases piston syringes and servo-motor valves as disclosed in US—A—3 900 289, US—A—3 982 667 and US—A—4 141 469.

The rare peristaltic pump type dispensers require a separately operated pump head for each dispensing channel. In order to dispense more than one reagent, precision syringe and displacement mechanism is needed for each additional channel. The cost requirement in this latter case can be multiple compared to the price of the multichannel peristaltic pumps. Furthermore, one of the main difficulties is in the lack of independent control of the channels.

From US—A—3 419 358 a method for diluting a fluid for preparation of automatic analysis is known. Sample liquid to be diluted in a container and sipped therefrom by means of an aspirator vacuum pump. The vacuum pump is operated by a pressure medium being a diluent sipped from another container, by means of a centrifugal pump. Pressure or flow rate, respectively, of the diluent have to be exactly set for maintaining the desired ratio between diluent and sample liquid. This is achieved by two valve means downstream the centrifugal pumps since the centrifugal pump is not capable per se to deliver a predetermined and constant amount of pressure medium.

The main object of this invention is to eliminate the deficiencies of the known solutions and to provide a method and an apparatus with which a fluid can be dispensed, pipetted and diluted in a more convenient and precise way.

According to this invention, this object is solved in such a way that in the method as described in the first paragraph hereinabove, a multichannel peristaltic pump is used, a predetermined amount of the fluid is sipped by opening valve means in the tube on the suction side of the pump for an adequate time, a predetermined amount of the fluid is dispensed by opening said valve means in the tube on the pressure side of the pump, and the control of both valve means is influenced by rotational speed fluctuations of the pump drive and/or by pulsation of the pump.

In a preferable embodiment of the method according to this invention, the fluid delivered by the pump is lead through a controlled two-way switch valve either into a fluid container on the suction side of the pump or, for dispensing, to a

dispensing tube. Expediently, the sucking effect of the pump in the dispensing tube may be controlled by a two-way switch valve.

According to this invention, in the apparatus for dispensing and pipetting fluids comprising a pump and controlled valve means in a tube on the pressure side of the pump, the pump is a multichannel peristaltic pump, a pressure side tube of the pump is connected through a controlled switch valve to a fluid container on the suction side of the pump or to a dispensing tube, and a control unit is attached to said switch valve and is electrically connected to a sensor of a chopper fixed to an axis of the pump.

In a preferred embodiment of the apparatus according to this invention, a suction side tube of the pump is connected through an additional controlled switch valve either to said fluid container or to a dispensing and pipetting tube. A further pressure side tube may be connected to the fluid container and a further suction side tube may be connected through the additional controlled switch valve either to the fluid container or to the pipetting and dispensing tube.

The method and the apparatus according to this invention have the advantage that the fluid can be dispensed, pipetted and diluted in a most convenient and precise way. The costs for manufacturing that apparatus and for proceeding in accordance with that method are relatively low.

Further details of this invention will be described hereinafter with reference to the attached drawing. In the drawing,

Fig. 1 is a schematic block diagram of one embodiment of this invention,

Fig. 2 shows another embodiment, and

Fig. 3 illustrates a further embodiment of the invention.

The apparatus shown in Fig. 1 has a peristaltic pump 1, a fluid container 2, a controlled valve 3a, tubes 4b, 5a, 5b, 6 and a control unit 7. With this system, fluid dispensing can be carried out according to the method of this invention.

An apparatus capable to carry out pipetting is shown in Fig. 2, where an additional controlled switch-valve 3b is built into the sipping side of pump 1, i.e. into tube 4a.

In Fig. 3, an embodiment of this invention for pipetting and consecutively diluting is shown. Tubes 4d and 5d are connected to another channel of the peristaltic pump 1.

The realisation of the method in this invention will be described by illuminating the operation of the apparatus. In Fig. 1, the peristaltic pump 1 delivers the contents of container 2 through tubes 4b, 5a towards controlled valve 3a, which is closed towards tube 6 and open towards tube 5b before the dispensing cycle. Thus, a constant rate of recirculation is maintained. If the valve 3a is switched over for a certain period of time determined by the control unit 7 the selected amount of liquid leaves the dispensing tube 6. The timing signal for the control unit 7 is given by a chopper fixed to the axis of the peristaltic pump 1.

The frequency of the impulses is preferably unit

multiple of the pulsation frequency of the pump, which is known to emanate from the rollers that lift off from the tubes one after the other. The exact time of the valve switching has to be selected in such a manner that it occurs in all cases at the minimum point of the pulsation.

This can be achieved by delaying the said signal or by fixing the signal chopper in the right phase. In this manner, the minimum dispensable volume for each tube diameter of the pump is given by the distance of the rollers that is the "length" of the pressure pulses. However, with a pump having a negligible pulsation only, the frequency of the signal chopper and, thus, the minimum dispensable volume is limited only by the general technical parameters.

The channels of a multichannel peristaltic pump can independently be equipped with controlled valves as is shown in the figure. Thus, each channel can be used for dispensing independently from each others without disturbing the even rotation of the pump.

The pipetting procedure will be explained with reference to Fig. 2. Auxiliary to Fig. 1, is a switch-valve 3b connected into the suction side of the pump 1. Switch-valve 3b connects the suction side tube 4a either through tube 4b to the fluid container 2 or, in the other setting of the valve 3b, through tube 6b to the pipet and outlet tube 6c. The timing signal arrives from the pump 1 and serves as a basis for the control of both valves. The pipetting cycle of the system filled already with the fluid is as follows:

In the preparatory stage, the pump 1 is circulating the fluid through tubes 4a, 4b, 5a, 5b. The pipet tip 6c, which contains some microliter air gap (see last step of the cycle) is immersed into the fluid sample to be pipetted. At that time, the control unit 7 switches over the valve 3b for a short time, or for an appropriate number of pulses and, thus, the desired amount of sample will flow into tube 6c. The sipping is finished and the pump works through tubes 4b and 5b again. During this time, the pipet tip 6c is placed above the appropriate vessel and dispensing can be started. This occurs by switching over the valve 3a in the same manner as described with Fig. 1. If pipetting is carried out without dilution, the active time of the valves 3a and 3b is equal. In the case, the pipet tip 6c can be flushed by a small amount of fluid from inside. The flush fluid if required serves for the dilution of the sample. At the end of the cycle, a little amount of air can be sucked by switching over valve 3b for a short time, while the tip is held in the air.

If the sample to be pipetted should be dispensed with a larger amount of diluting fluid, the total pipetting cycle time may be too long when using the arrangement in Fig. 2. For this purpose, the embodiment of Fig. 3, built up in a different manner, while functionally is equivalent to that of Fig. 2. The rate of outflow is determined by the cross section of the pump tube 4a, 5a, whereas the inflow sipping rate is determined by the delivery rate of the pump tube 4d, 5d.

The method according to the present invention makes it possible to utilize a multichannel peristaltic pump and more controlled valves to build different systems and establish further additional operational functions. Thus, automatic titration will be possible with the system on Fig. 1 if an end point indicator is connected to the control unit.

### Claims

1. A method for dispensing, pipetting and consecutively diluting fluids, wherein a constant stream of the fluid is established and maintained in a part of a tube by means of a pump and a predetermined amount of the fluid is dispensed by opening valve means in said tube on the pressure side of the pump,

characterized by

using a multichannel peristaltic pump;

sipping a predetermined amount of the fluid by opening valve means in the tube on the suction side of the pump for an adequate time;

dispensing a predetermined amount of the fluid by opening said valve means in the tube on the pressure side of the pump;

influencing control of both valve means by rotational speed fluctuations of the pump drive and/or by pulsation of the pump.

2. A method as claimed in claim 1, characterized in that the fluid delivered by the pump is lead through a controlled two-way switch valve either into a fluid container on the suction side of the pump or, for dispensing, to a dispensing tube.

3. A method as claimed in claim 2, characterized in that the sucking effect of the pump in the dispensing tube is controlled by a two-way switch valve.

4. An apparatus for dispensing and pipetting fluids comprising a pump and controlled valve means in a tube on the pressure side of the pump, characterized in that the pump is a multichannel peristaltic pump (1), a pressure side tube (5a) of the pump (1) is connected through controlled switch valve (3a) to a fluid container (2) on the suction side of the pump (1) or to a dispensing tube (6), and a control unit (7) is attached to the switch valve (3a) and is electrically connected to a sensor of a chopper fixed to an axis of the pump (1).

5. An apparatus as claimed in claim 4, characterized in that a suction side tube (4a) of the pump (1) is connected through an additional controlled switch valve (3b) either to the fluid container (2) or to a dispensing and pipetting tube (6c).

6. An apparatus as claimed in claim 5, characterized in that a further pressure side tube (5d) is connected to the fluid container (2) and a further suction side tube (4d) is connected through the additional controlled switch valve (3b) either to the fluid container (2) or to the pipetting and dispensing tube (6c).

### Patentansprüche

1. Verfahren für die Ausgabe, Pipettierung und

fortlaufende Verdünnung von Flüssigkeiten, bei dem ein konstanter Strom der Flüssigkeit mit Hilfe einer Pumpe aufgebaut und in einem Teil einer Röhre erhalten wird und bei dem eine festgelegte Menge der Flüssigkeit durch das Öffnen einer Ventilvorrichtung in der Röhre auf der Druckseite der Pumpe ausgegeben wird,

gekennzeichnet durch

den Einsatz einer Mehrweg-Peristaltik-Pumpe;

das Ansaugen einer vorher festgelegten Menge der Flüssigkeit durch das Öffnen der Ventilvorrichtung in der Röhre auf der Saugseite der Pumpe für eine angepaßte Zeitspanne;

die Ausgabe einer festgelegten Menge der Flüssigkeit durch Öffnen der Ventilvorrichtung in der Röhre auf der Druckseite der Pumpe;

die Beeinflussung der Steuerung der beiden Ventilvorrichtungen durch Schwankungen der Rotationsgeschwindigkeit des Pumpenantriebs und/oder durch Pulsieren der Pumpe.

2. Verfahren nach Anspruch 1, dadurch gekennzeichnet, daß die Flüssigkeit, die durch die Pumpe gefördert wird, durch ein gesteuertes Zwei-Wege-Ventil entweder in einen Flüssigkeitsbehälter auf der Saugseite der Pumpe oder zur Ausgabe in eine Ausgaberöhre geleitet wird.

3. Verfahren nach Anspruch 2, dadurch gekennzeichnet, daß der Saugeffekt der Pumpe in der Ausgaberöhre durch ein Zwei-Wege-Ventil gesteuert wird.

4. Vorrichtung für die Ausgabe und Pipettierung von Flüssigkeiten, die eine Pumpe und eine gesteuerte Ventilvorrichtung in einer Röhre auf der Druckseite der Pumpe aufweist, dadurch gekennzeichnet, daß die Pumpe eine Mehrweg-Peristaltik-Pumpe (1) ist, eine Druckseitenröhre (5a) der Pumpe (1) über ein gesteuertes Schaltventil (3a) mit einem Flüssigkeitsbehälter (2) auf der Saugseite der Pumpe (1) oder mit einer Ausgaberöhre (6) verbunden ist und eine Steuereinheit (7) an dem Schaltventil (3a) angebracht und elektrisch mit einem Sensor eines Zerhackers verbunden ist, der an der Welle der Pumpe (1) befestigt ist.

5. Vorrichtung nach Anspruch 4, dadurch gekennzeichnet, daß eine Saugseitenröhre (4a) der Pumpe (1) über ein zusätzliches gesteuertes Schaltventil (3b) entweder mit dem Flüssigkeitsbehälter (2) oder mit einer Ausgabe- und Pipettieröhre (6c) verbunden ist.

6. Vorrichtung nach Anspruch 5, dadurch gekennzeichnet, daß eine weitere Druckröhre (5d) mit dem Flüssigkeitsbehälter (2) verbunden ist und eine weitere Saugseitenröhre (4d) über ein zusätzliches gesteuertes Schaltventil (3b) entweder mit dem Flüssigkeitsbehälter (2) oder mit der Pipettier- und Ausgaberöhre (6c) verbunden ist.

#### Revendications

1. Procédé pour la distribution, le pipetage et la dilution consécutive de fluides, selon lequel un écoulement constant du fluide est établi et main-

tenu dans une partie d'un tube au moyen d'une pompe et une quantité prédéterminée du fluide est distribuée grâce à l'ouverture de moyens en forme de soupape situés dans ledit tube sur le côté refoulement de la pompe,

caractérisé en ce qu'il consiste à:

utiliser une pompe péristaltique à canaux multiples;

prélever une quantité prédéterminée du fluide en ouvrant les moyens en forme de soupape situés dans le tube sur le côté aspiration de la pompe, pendant un intervalle de temps approprié;

distribuer une quantité prédéterminée du fluide en ouvrant lesdits moyens en forme de soupape situés dans le tube sur le côté refoulement de la pompe;

influencer la commande des deux moyens en forme de soupapes au moyen de variations de la vitesse de rotation du dispositif d'entraînement de la pompe et/ou au moyen de la pulsation de la pompe.

2. Procédé selon la revendication 1, caractérisé en ce que le fluide délivré par la pompe est envoyé, par l'intermédiaire d'une soupape de commutation bidirectionnelle commandée, soit dans un réservoir de fluide situé sur le côté aspiration de la pompe soit, pour la distribution, à un tube de distribution.

3. Dispositif selon la revendication 2, caractérisé en ce que l'effet d'aspiration de la pompe dans le tube de distribution est commandé par une soupape de commutation bidirectionnelle.

4. Dispositif de distribution et de pipetage de fluides, comportant une pompe et des moyens en forme de soupape commandés, situés dans un tube sur le côté refoulement de la pompe, caractérisé en ce que la pompe est une pompe péristaltique (1) à canaux multiples, qu'un tube (5a) situé sur le côté refoulement de la pompe (1) est raccordé par l'intermédiaire d'une soupape de commutation commandée (3a) à un réservoir de fluide (2) situé sur le côté aspiration de la pompe (1), ou à un tube de distribution (6), et une unité de commande (7) est raccordée à la soupape de commutation (3a) et est reliée électriquement à un capteur d'un hacheur fixé sur un axe de la pompe (1).

5. Appareil selon la revendication 4, caractérisé en ce qu'un tube (4a) situé sur le côté aspiration de la pompe (1) est raccordé par l'intermédiaire d'une soupape de commutation commandée additionnelle (3b) soit au réservoir de fluide (2), soit à un tube de distribution et de pipetage (6c).

6. Appareil selon la revendication 5, caractérisé en ce qu'un autre tube (5d) situé sur le côté refoulement est raccordé au réservoir de fluide (2) et qu'un autre tube (4d) situé sur le côté aspiration est raccordé par l'intermédiaire de la soupape de commutation commandée additionnelle (3b) soit au réservoir de fluide (2), soit au tube de pipetage et de distribution (6c).

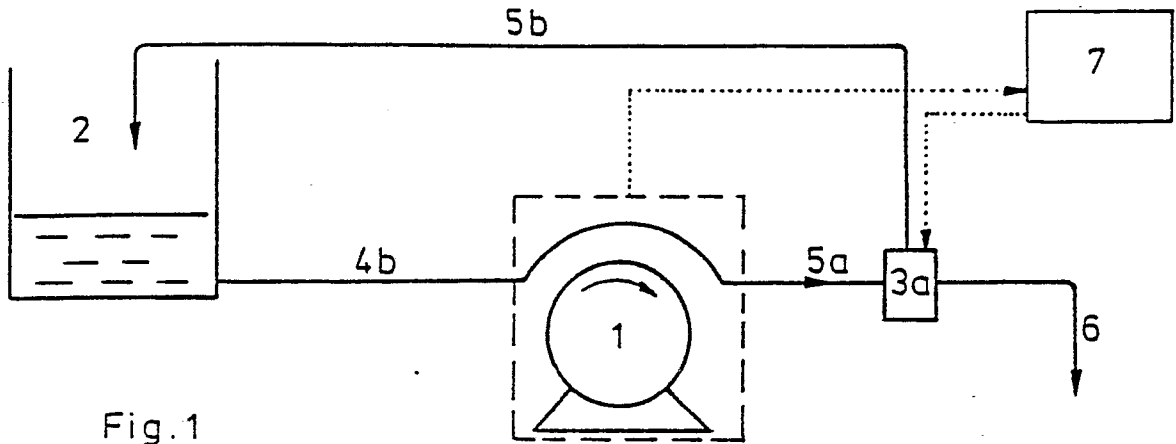

Fig. 1

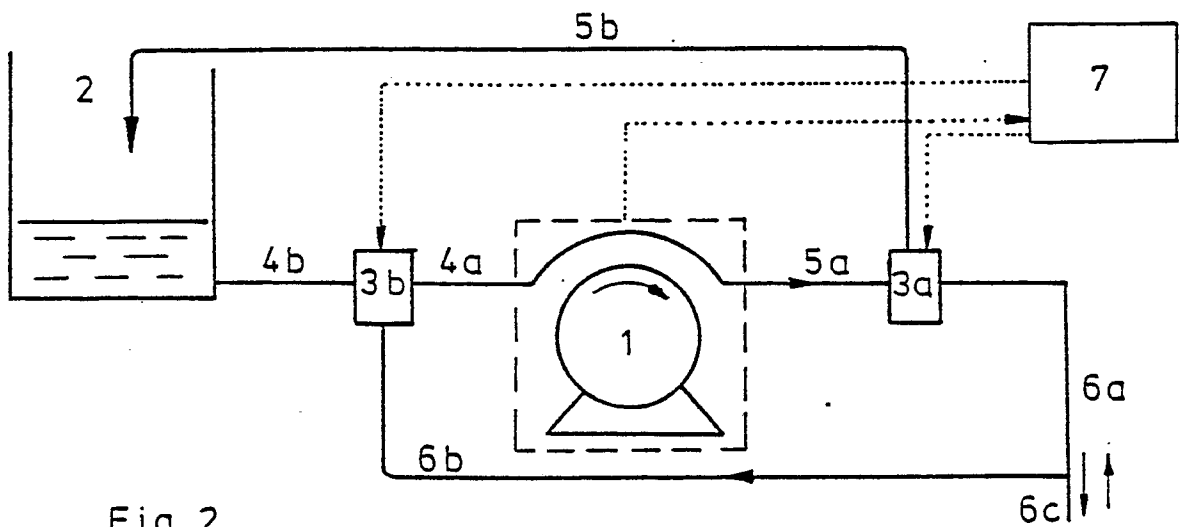

Fig. 2

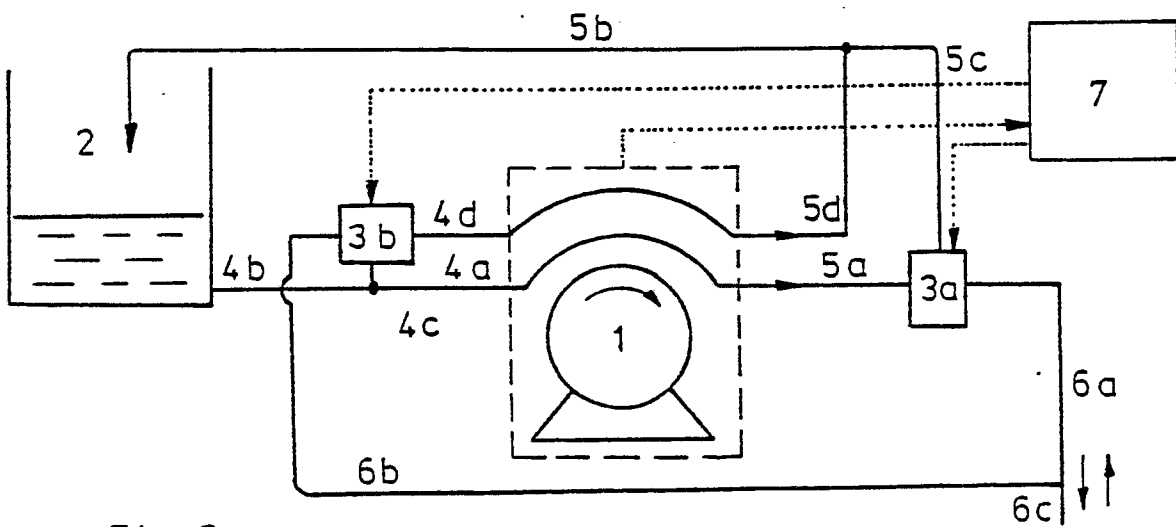

Fig. 3