

W.C Shaw,
Mortising Machine,
No. 9, 156, Patented July 27, 1852.

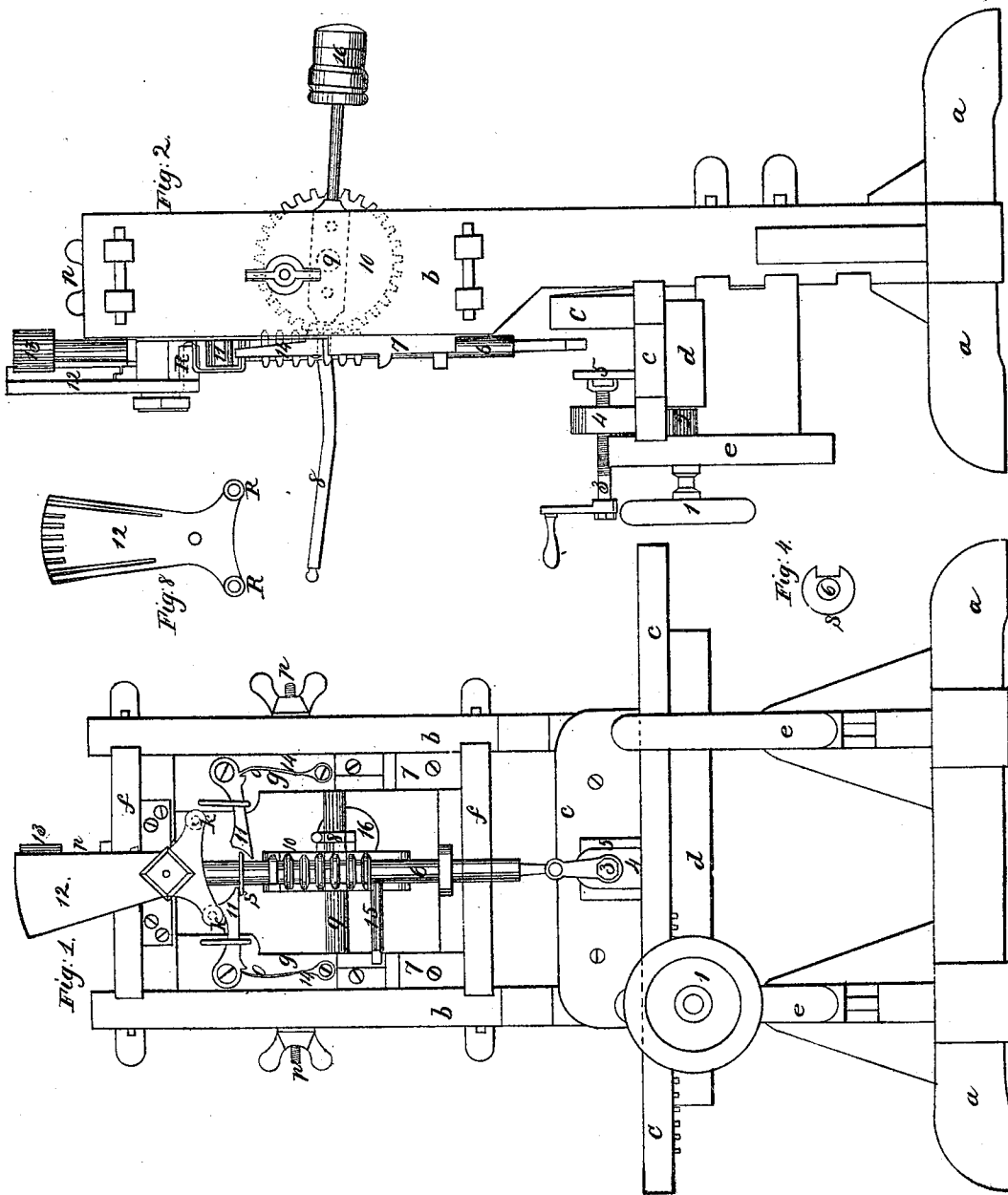

UNITED STATES PATENT OFFICE.

WM. C. SHAW, OF MADISON, INDIANA.

MORTISING-MACHINE.

Specification of Letters Patent No. 9,156, dated July 27, 1852.

To all whom it may concern:

Be it known that I, WILLIAM C. SHAW, of Madison, in the county of Jefferson and State of Indiana, have invented a new and useful Improvement in Mortising-Machines; and I do hereby declare that the following is a full and exact description thereof, reference being had to the annexed drawings, making a part of this specification.

Similar letters and figures refer to corresponding parts of the machine.

Figure 1 is a front elevation showing the parts of the machine in a working condition. Fig. 2 is a side elevation of the machine, which represents some of the inside work by dotted lines. Fig. 3 is a back view of the piece that turns the mandrel around that contains the mortising chisel. Fig. 4 is a sectional view of the mandrel 6.

The nature of my invention consists in providing the machine with suitable mechanism for the purpose of enabling the operator to turn the chisel by means of the machinery employed for the purpose and not by hand, as is commonly done.

The following will be found a description of my machine and concluding with what I claim as my invention.

(*a, a,*) is the foot or base of the machine.

(*b, b,*) is the main side uprights.

(*c, c, c,*) is the table used for the purpose of holding pieces on to be mortised, by means of the screw (3) and press plate (5). The screw 3 works in the upright (4). The table is furnished with a rack underneath on the front edge, which is worked by the wheel (1) and pinion (2). The pinion is seen in Fig. 2 only.

(*e, e,*) is guides in front of the table.

(*f, f,*) is cross pieces connecting the uprights together and forming an opening for the frame (*g, g,*) which contains the mandrel (6) and working through guides prepared for the purpose at the top and bottom of the frame.

(7, 7,) is slide guides used for guiding the mandrel when in operation by means of the guide piece (15) screwed in the side of the mandrel as is represented in Fig. 1.

(14, 14,) is springs used for the purpose of holding up the catches (11, 11,). The catches is used to turn or throw the piece (12) to the right and left as the case may

be, by striking the projections (*k, k,*) on the lower end of the piece (12,) which is furnished with rings that revolve for the purpose of lessening the friction. The piece (12) is furnished with a rack at the back part (which is represented in Fig. 3) and works in the pinion (13) on the top of the mandrel, which turns the mandrel around by elevating the lever (8) above its usual height of working. The mandrel is furnished with a collar (*s*) which forces the catch against the rolls or rings (*k k*) on the lower part of piece (12) and causes it to turn the pinion (13) which reverses the chisel placed in the lower part of the mandrel. There is a notch but in one side of the collar (*s*) so as to pass by one of the catches, while the other is in the act of turning the mandrel (the collar is represented in Fig. 4).

(10) is a cog wheel working in the cylindrical rack on the mandrel (6). (9) is the shaft that supports it. (8) is the lever it is worked with. (16) is a counterbalance on the back end of the lever (8) to prevent the mandrel from having a tendency to fall. (*h, h, h,*) represents screws used for the purpose of setting the frame (*g, g*) farther back or forward as the nature of the case may require. Two of the screws are placed on the sides of the machine; the other one is put in the top, which is but partly seen.

The table (*d*) if required can be set lower down for the purpose of receiving a deeper piece to be mortised. The drawings represent a provision for such a purpose by another mortise passing through the upright pieces (*b b*) seen in Fig. 1.

What I claim as my invention and desire to have secured to me by Letters Patent is—

The method I employ for turning the mandrel (6) that contains the mortising chisel by means of the collar (*s*) on the mandrel, springs (14, 14) catches (11, 11), shifting piece (12), friction rings (*k, k*) and pinion (13), all in combination for the purpose heretofore mentioned and set forth in the foregoing specifications.

WILLIAM C. SHAW.

Witnesses:

E. D. WITHERS,
MARTIN BENSON.