

C. M. Gress. Treadle Motion. PATENTED AUG 30 1870

106813

Fig. 2.

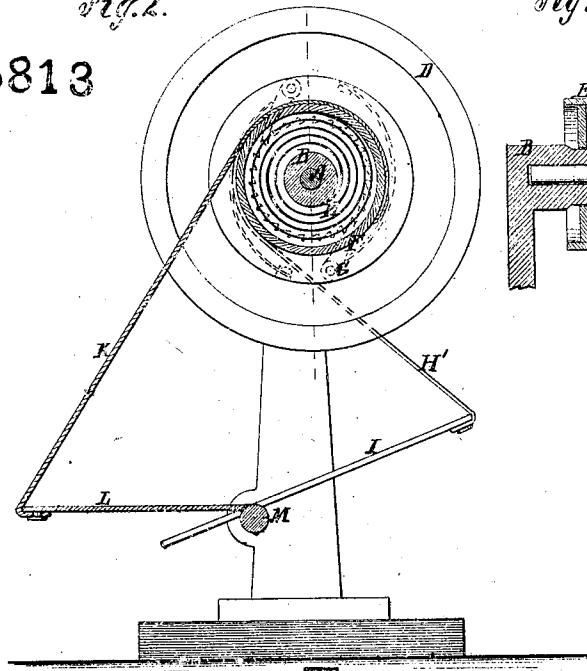

Fig. 3.

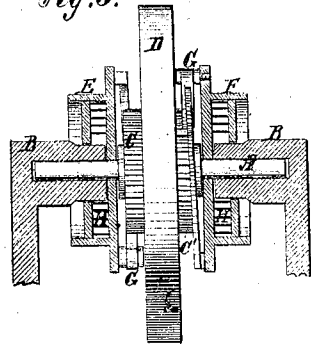
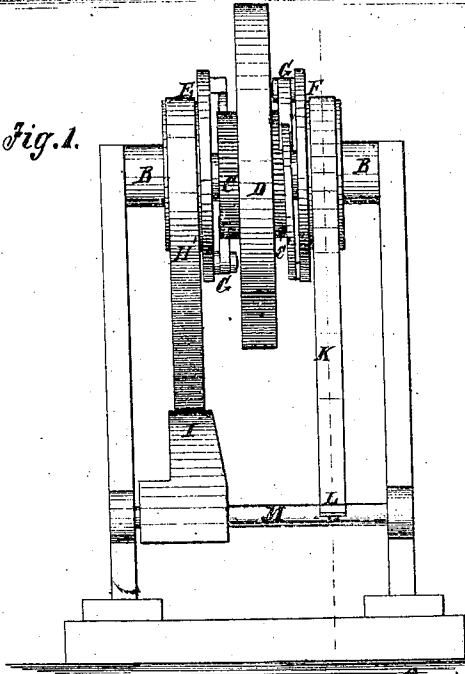

Fig. 1.



Witnesses:

A. Benneimendof.
Geo. W. Mable

Inventor:

C. M. Gress
PER *Mumford*
Attorneys.

United States Patent Office.

CHARLES M. GUESS, OF NEW ORLEANS, LOUISIANA.

Letters Patent No. 106,813, dated August 30, 1870.

IMPROVEMENT IN TREADLE-MOTION.

The Schedule referred to in these Letters Patent and making part of the same.

To all whom it may concern:

Be it known that I, CHARLES M. GUESS, of New Orleans, in the parish of Orleans and State of Louisiana, have invented a new and improved Treadle-Motion; and I do hereby declare that the following is a full, clear, and exact description of the same, reference being had to the accompanying drawing forming a part of this specification.

My invention relates to treadle devices, and my principal object is to secure a more convenient mechanism for operating sewing-machines.

The invention consists in certain improvements which will be first described in connection with all that is necessary to a full understanding thereof, and then clearly specified in the summary or claim.

Figure 1 is a front view;

Figure 2, a vertical section through one of the pulleys: and

Figure 3, a transverse vertical section through the pulley-shaft.

A is the driving-shaft of a sewing-machine, turning in bearings B;

D is a balance-wheel, fast on the shaft; and

C C, ratchet-wheels, firmly attached to its sides.

E F represent loose pulleys, having pawls G, held by spring pressure to the ratchet-wheels.

H K are belts, attached to the loose pulleys, and wound about them in the same direction.

I is the foot-treadle, and

L an independent arm, both attached to the rocking-shaft M, but on opposite sides, and each having one of the belts affixed to its outer end.

Each of the pulleys E F is provided with a retracting spring, H, but of different tensional power.

The pulley F requires a spring with just sufficient tension to wind up the loose belt K, as the shaft M is vibrated by the foot of the operator, while the pulley E requires sufficient tension to rotate the shaft A

to a certain distance, in spite of the resistance of the light spring of the other pulley.

The mode of operation is as follows:

A person, placing his foot upon the treadle I, rotates the shaft a half revolution, (or, according to the relative length of the arc in which the treadle moves,) and the circumference of pulley F winds up its belt K. The foot of the operator being removed, the strong spring or pulley E winds belt H, raises arm H, vibrates shaft M, depresses arm L, and unwinds belt K, thereby continuing the rotation of shaft A.

Of course, each pressure of the foot exerts double the power which it would on a single treadle, and this additional power is stored up in the strong spring of pulley E, to be utilized on the return movement.

The power, however, required to propel the driving-shaft of a sewing-machine is small, and the difference in amount is scarcely perceptible to the operator.

Having described all that is necessary to an understanding of my invention,

What I claim as new, and desire to secure by Letters Patent, is—

1. The arrangement in pulleys E F of a sewing-machine treadle device, of unequal and reversely-operating springs H H, as and for the purpose described.

2. The two reversely-operating and unequal springs H H, loose pulleys E F, and opposite arms I L of rock-shaft M, combined with two belts K H, passing over their respective pulleys in the same direction, as and for the purpose described.

The above specification of my invention signed by me this 17th day of May, 1870.

CHARLES M. GUESS.

Witnesses:

GEO. W. MABEE,
ALEX. F. ROBERTS.