

(19) World Intellectual Property Organization
International Bureau



(43) International Publication Date
27 June 2002 (27.06.2002)

PCT

(10) International Publication Number
WO 02/49560 A1

(51) International Patent Classification⁷: A61F 13/15

(21) International Application Number: PCT/SE01/02717

(22) International Filing Date:
10 December 2001 (10.12.2001)

(25) Filing Language: Swedish

(26) Publication Language: English

(30) Priority Data:
0004738-1 20 December 2000 (20.12.2000) SE

(71) Applicant: SCA HYGIENE PRODUCTS AB [SE/SE];
S-405 03 Göteborg (SE).

(72) Inventor: ÉEN, Hans; Urbergsvägen 2, S-435 41 Mölnlycke (SE).

(74) Agents: ANDERSSON, Per et al.; Albihns Göteborg AB,
P.O. Box 142, S-401 22 Göteborg (SE).

(81) Designated States (*national*): AE, AG, AL, AM, AT, AU, AZ, BA, BB, BG, BR, BY, BZ, CA, CH, CN, CO, CR, CU, CZ, DE, DK, DM, DZ, EC, EE, ES, FI, GB, GD, GE, GH, GM, HR, HU, ID, IL, IN, IS, JP, KE, KG, KP, KR, KZ, LC, LK, LR, LS, LT, LU, LV, MA, MD, MG, MK, MN, MW, MX, MZ, NO, NZ, OM, PH, PL, PT, RO, RU, SD, SE, SG, SI, SK, SL, TJ, TM, TR, TT, TZ, UA, UG, UZ, VN, YU, ZA, ZM, ZW.

(84) Designated States (*regional*): ARIPO patent (GH, GM, KE, LS, MW, MZ, SD, SL, SZ, TZ, UG, ZM, ZW), Eurasian patent (AM, AZ, BY, KG, KZ, MD, RU, TJ, TM), European patent (AT, BE, CH, CY, DE, DK, ES, FI, FR, GB, GR, IE, IT, LU, MC, NL, PT, SE, TR), OAPI patent (BF, BJ, CF, CG, CI, CM, GA, GN, GQ, GW, ML, MR, NE, SN, TD, TG).

Published:
— with international search report

For two-letter codes and other abbreviations, refer to the "Guidance Notes on Codes and Abbreviations" appearing at the beginning of each regular issue of the PCT Gazette.

(54) Title: ABSORBENT PRODUCT COMPRISING LEAKAGE BARRIERS

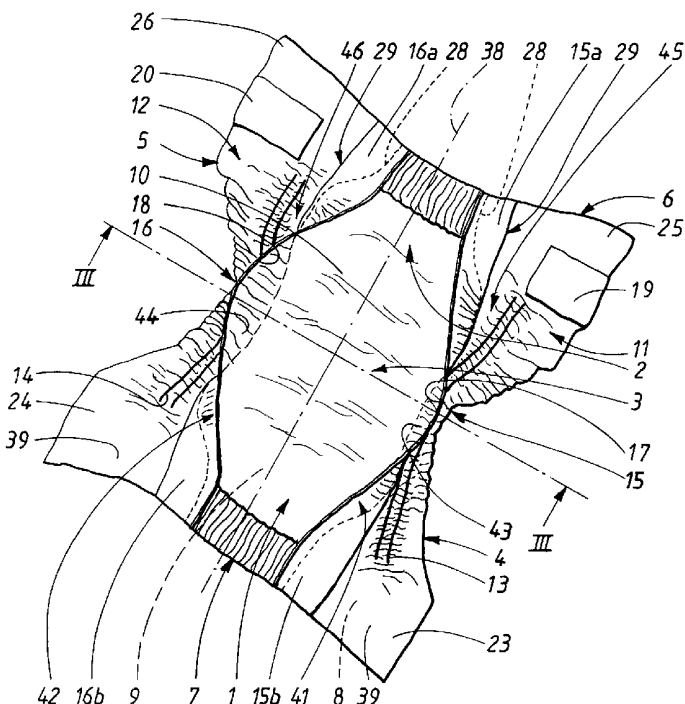

(57) Abstract: Absorbent product, such as a diaper, a pant diaper, an incontinence pad, a sanitary towel or the like, comprising an absorption body (9) having a generally oblong shape with two longitudinal sides (4, 5), two transverse sides (6, 7), a longitudinal centre line (38), and also comprising a first, liquid-permeable surface layer (10) and a second, essentially liquid-impermeable surface layer (39), an essentially liquid-impermeable backing layer (8), an absorption body (9) positioned between said liquid-permeable surface layer (10) and said backing layer (8), two leakage barriers (15, 16) made of flexible material in the longitudinal direction on each side of the longitudinal centre line (38) and the first, liquid-permeable surface layer (10). Each leakage barrier (15, 16) has a first edge (45, 46) permanently fastened along the first, liquid-permeable surface layer (10) and a second edge (17, 18) which extends in the direction of the longitudinal centre line (38) of the absorbent product. Each leakage barrier (15, 16) also has a first surface (41, 42) and a second surface (43, 44). The first surface (41, 42) and/or the second surface (43, 44) of each said leakage barrier (15, 16) is fastened to or

near to the first, liquid-permeable surface layer (10) and/or the second, liquid-impermeable surface layer (39).

WO 02/49560 A1

ABSORBENT PRODUCT COMPRISING LEAKAGE BARRIERS

TECHNICAL FIELD

5 The invention relates to an absorbent product, such as a diaper, a pant
diaper, an incontinence pad, a sanitary towel or the like, comprising an
absorption body having a generally oblong shape with two longitudinal sides,
two transverse sides, a longitudinal centre line, a transverse centre line, and
also comprising a first, liquid-permeable surface layer and a second, liquid-
10 impermeable surface layer, a liquid-impermeable backing layer, an
absorption body positioned between said liquid-permeable surface layer and
said backing layer, two leakage barriers made of flexible material in the
longitudinal direction on each side of the longitudinal centre line and the
first, liquid-permeable surface layer, each of the leakage barriers having a
15 first edge permanently fastened along the first, liquid-permeable surface
layer and a second edge which extends mainly in the direction of the
longitudinal centre line of the absorbent product, each of the leakage
barriers also having a first surface and a second surface.

20 BACKGROUND ART

In order to prevent the risk of leakage at the side edges of an absorbent
product, some absorbent products have what are known as standing or
raised leakage barriers, also referred to as inner liquid barriers, standing
25 barriers or cuffs, in most cases fastened in association with a liquid-
impermeable surface layer on the product. The function of the leakage barrier
is to prevent liquid leaking out at the edges of the absorbent product and, if
appropriate, to prevent leakage of solids such as motions. These leakage
barriers are located inside the leg elastic, which shapes the product and
30 constitutes an outer liquid barrier, also referred to as the outer leakage
barrier, and are usually made of an essentially liquid-impermeable material,

for example fibre fabric, which is also known as non-woven. Sometimes, the barriers can also be made of liquid-permeable material. The leakage barriers are formed by a web, one longitudinal edge of which is fastened to the absorbent product and the other, free edge of which is intended to bear
5 against the wearer. The free edge is elastically gathered by means of an elastic thread which is incorporated into the edge of the web. Examples of absorbent articles with leakage barriers (or what are known as liquid barriers) are described in, for example, WO-A1-9207533, US 4695278, US 5064489, SE-T3-0264238 and GB-A-2188532. When the absorbent product
10 has leakage barriers arranged inside flexible side flaps on both sides of the absorption body of the product, it is usual for the surface material between the two inner leakage barriers, that is to say in the liquid-receiving area, to be liquid-permeable, while the surface material outside the leakage barriers is essentially liquid-impermeable.

15

On diapers with what are known as inner leakage barriers, for example, the barrier will, during use, be positioned so that it bears against the leg and buttocks of the wearer and is to prevent leakage there. Each time urine is discharged into the diaper, a certain quantity comes in one go. It takes a
20 little time before the urine penetrates the surface layer and is absorbed in the absorbent layer, so a certain volume of urine will flow in the absorbent product on top of the surface layer. This is the volume which the barrier is to prevent leaking out at the edges of the absorbent product.

25 New problems arise precisely because of the purpose and material characteristics of the leakage barriers. The leakage barriers, which are essentially liquid-impermeable, can, when the product is put on the wearer, lie over the liquid-permeable surface layer instead of fitting tightly around the thighs and buttocks of the wearer. This may be as a result of the product
30 having been tightened too firmly, incorrectly, carelessly or the like. When a leakage barrier lies incorrectly, there may be unfavourable consequences in

the form of poor fit and unoptimized dimensional stability. The greatest problem, however, is in the increased risk of leakage. There are two main reasons for increased leakage, the first being that the leakage barriers are no longer positioned where they are intended to be, which can give rise to

5 openings between the thighs of the wearer and the product, where liquid can escape. The second is that the leakage barriers can lie on the liquid-permeable surface layer and thus prevent the liquid from being admitted into and absorbed in the absorption body. Instead, the liquid runs on or via the liquid-impermeable surface of the leakage barriers, and thus gives rise to

10 leakage and discomfort.

For bedridden wearers, the problem is marked when the person fitting the absorbent product may perhaps be unable to arrange everything properly. The wearer may be, for example, a heavy person, while the person applying

15 the product might not have sufficient strength in order to perform all the necessary lifting and turning. This means that it is important to ensure everything is correct the first time the absorbent product is put on, so that no further action has to be taken.

20 The problem of leakage barriers lying incorrectly is especially marked with an absorbent product with a narrow crotch portion, that is to say the distance between the longitudinal sides of the absorption body is relatively small. The leakage barriers may then cover a greater percentage of the area of the liquid-permeable surface layer and thus indirectly of that surface of the

25 absorption body facing the wearer than if the distance between the longitudinal sides of the absorption body is relatively great. In the same way, a high leakage barrier, that is to say a barrier where the distance between the longitudinal edges of the leakage barrier is great, can cover a greater percentage of the area of the liquid-permeable surface layer and thus

30 indirectly of the absorption body than if the distance between the longitudinal edges of the leakage barrier is small.

The object of the invention is to solve these problems in a refined manner which is comfortable for the wearer.

5 DISCLOSURE OF THE INVENTION

By means of the present invention, an absorbent product of the type mentioned in the introduction has been produced, which product essentially eliminates the problems associated with previously known such products. A
10 product made according to the invention is characterized mainly in that the first surface and/or the second surface of each leakage barrier is fastened to or near to the first, liquid-permeable surface layer and/or the second, liquid-impermeable surface layer.

15 According to one embodiment, the first surface and/or second surface of each said leakage barrier is temporarily fastened by a binder which loses its adhesive and/or cohesive capacity during use of the absorbent product, the first surface and/or second surface of each leakage barrier then coming away from its fastening surface and becoming a raised leakage barrier.

20

Binder means an agent which has an adhesive and/or cohesive capacity, for example glue or wax, but it is also possible within the scope of the invention to use a binder such as, for example, ultrasonic welding and thermal
welding.

25

Here and henceforth, the term fastening surface means one or more surfaces to which the binder (which is intended to lose its adhesive and/or cohesive capacity during use) is applied on the leakage barriers. The surface or surfaces where the binder is applied, that is to say the fastening
30 surface, can in principle have any shape and be positioned in one or more different places on the leakage barriers. Here and henceforth, the term

fastening surface does not therefore contain any limitation in terms of the number or shape of fastening surfaces.

It is of course impossible to avoid an interaction among various parameters, for example temperature, atmospheric humidity, choice of material, tensile forces or shear forces etc., which together contribute to a binder losing its adhesive and/or cohesive capacity, but it is in most cases possible to distinguish the major influencing factor. Here, the major influencing factor means the factor which, without the other factors, would be capable of achieving essentially the same result, although possibly after a somewhat longer time. Henceforth, the major influencing factor in order for the binder to lose its adhesive and/or cohesive capacity is meant.

One type of binder in the form of a glue which will lose its adhesive and/or cohesive capacity during use is previously known from EP 0 571 548 B1. The temperature and pressure-sensitive glue in said patent has what is known as a Normal Use Temperature Zone (NUTZ) which has a minimum temperature and a maximum temperature. The glue loses its adhesive and/or cohesive capacity completely or partly when the temperature either rises above the maximum temperature or falls below the minimum temperature, that is to say leaves the NUTZ range.

After the product has been fitted on the wearer, the body temperature of the wearer will raise the temperature in the absorbent product and in this way the temperature of the glue also. As a result, the temperature functions as a trigger or activating means for the glue and the leakage barriers. A glue suitable for the invention loses its adhesive and/or cohesive capacity within the range 27-40°C, preferably within the range 29-38°C and most preferably within the range 30-37°C, the first and/or second surface of the leakage barriers then coming away from its fastening surfaces and becoming a standing or raised leakage barrier. This completely avoids the risk that (as in

- conventional diapers, incontinence products or other absorbent products with leakage barriers) the standing leakage barriers can end up askew when the absorbent product is put on the wearer, unnecessary leakage also being avoided in this way, or that the leakage barriers can end up partly over the
- 5 liquid-permeable surface layer and thus prevent liquid from escaping down to the absorption body. By means of the invention, therefore, the risk of liquid running out of the product on or via the leakage barriers has also been removed.
- 10 Another type of binder which could be used is waxes, oils or paraffins. Certain compositions which are today commonly included in inter alia lotions and skincare products can also be used (this does not exclude the possibility of considering using lotions and skincare products in their entirety, for example CAREMELT©, Henkel-Cognis, Sweden). Such compositions often
- 15 have relatively low melting points which can easily be varied by changing the content in the composition. Suitable compositions can contain substances from groups consisting of glycerides, C₁₄-C₂₂ fatty alcohols, C₁₂-C₂₂ fatty acids and C₁₂-C₂₂ fatty alcohol ethoxylates with a degree of ethoxylation of roughly 2 to roughly 30, or derivatives thereof. In most cases, animal and
- 20 vegetable oils contain a mixture of various saturated and unsaturated fatty acids. The expert in the field is very familiar with the possibility of influencing the melting point by increasing and/or decreasing the quantity of fatty acids in similar compositions, see table 1 and table 2 (values obtained from CRC Handbook of Chemistry and Physics 75th edition 1994-1995 p. 7-28, 7-29).

Oil	Melting point (°C)	Saturated fatty acids (%)				Unsaturated fatty acids (%)		
		C ₁₂ - Lauric acid	C ₁₄ - Myristic acid	C ₁₆ - Palmitic acid	C ₁₈ - Stearic acid	C ₁₆ - Palmitoleic acid	C ₁₈ - Oleic acid	C ₁₈ - Linoleic acid
Coco-nut oil	25.1	45.4	18.0	10.5	2.3	0.4	7.5	Trace
Cocoa butter	34.1	-	-	24.4	35.4	-	38.1	2.1
Palm oil	35.0	-	1.4	40.1	5.5	-	42.7	10.3
Palm kernel oil	24.1	46.9	14.1	8.8	1.3	-	18.5	0.7

Table 1. General content in various vegetable oils (% by weight).

Name	C atoms in chain	Melting point (°C)
Saturated		
Lauric acid	12	43
Myristic acid	14	54
Palmitic acid	16	62
Stearic acid	18	69
Unsaturated		
Oleic acid	18	13
Linoleic acid	18	-9
Palmitoleic acid	16	0

5

Table 2. Length of carbon chain and approximate melting point of various saturated and polyunsaturated fatty acids.

A composition suitable for the invention loses its adhesive and/or cohesive capacity within the range 27-40°C, preferably within the range 29-38°C and most preferably within the range 30-37°C.

5

It is also possible within the scope of the invention to use glue which loses its adhesive and/or cohesive capacity at TEWL values above 20 g/m²h. TEWL (transepidermal water loss) can be measured using what is known as an evaporimeter (an EP2 from Servomed, Varberg, Sweden). The instrument
10 is designed to measure the quantity of liquid which evaporates from the skin (in principle equivalent to the quantity transported through the skin) in g/m²h.

This value is commonly used as a measurement of the status of the skin with regard to the barrier function. However, the instrument can be used in
15 association with products which cover the skin in order then to obtain a measurement of the moisture content on the surface of the skin (the measuring method is described in greater detail in "A refined method to evaluate diapers for effectiveness in reducing skin hydration – using the adult forearm", F. J. Akin et al., Skin research & technology, 1997; 3:173-
20 176).

Instead of having a temperature-activated binder, the moisture content in the product can control the adhesive and/or cohesive properties of the binder. The moisture in an absorbent product can therefore be used in order to
25 cause the glue to lose its adhesive and/or cohesive capacity. It is generally known that when the skin is covered by a material, the moisture content in the covered area increases. Alternatively, it is possible within the scope of the invention to use a glue which, when the moisture content becomes very high, that is to say equivalent to wetting of the product, loses its adhesive
30 and/or cohesive capacity, that is to say the glue is water-soluble.

It is also possible within the scope of the invention to use glue which loses its adhesive and/or cohesive capacity at one or some values within the pH range 3-7. In addition to the fact that the skin has a specific pH, the pH of the urine, for example, can be used as the trigger for the glue to lose its adhesive and/or cohesive capacity.

According to another embodiment, the binder can be constituted by ultrasonic welding and/or a thermal bond of poor quality designed to lose its adhesive and/or cohesive capacity during use, for example when the product is subjected to mechanical action during use. It is also possible within the scope of the invention to conceive of the binder being constituted by ultrasonic welding and/or a thermal bond of good quality, executed in such a case with a smaller fastening surface than when the bond is made with poor quality. When the bond has been subjected to tensile and shear forces resulting from normal use of the absorbent product, it comes loose and loses its adhesive and/or cohesive capacity. A precondition for welding to be carried out is that materials to be welded have relatively alike melting points. Here, poor quality means, for example, a bond between two materials with relatively different melting points, that is to say, for example, that only one material melts and bonds to the other material, or that one material melts fully and the other only partly. Alternatively, it would be possible to consider that a bond of poor quality is formed when the energy supply is insufficient to melt the bonded material completely.

According to another embodiment, the binder consists of the binder of the leg elastic. When the leg elastic is fastened to the surface layers, this is usually performed using a hot-melt adhesive. If the quantity of this binder is not precisely adjusted, the binder can penetrate the surface layers in the leg portion, or escape at the edges of the leakage barriers. This excess quantity of binder can be used for fastening the leakage barriers.

According to one embodiment, the leakage barriers consist of or comprise a non-woven material or a laminate made of non-woven layers, which affords possibilities for great variation of the properties of the leakage barriers such as permeability, strength, softness and flexibility etc. A barrier laminate can
5 of course also comprise materials other than non-woven layers, for example plastic film.

BRIEF DESCRIPTION OF FIGURES

10 The invention will be described in greater detail below with reference to the figures shown in the appended drawings, in which:

Fig. 1 shows a diaper before use, with the leakage barriers folded down and fastened to the side flaps and the second surface layer;
15

Fig. 2 shows a diaper as it appears during use, with the leakage barriers standing or raised;

Fig. 3a shows a part of the front end portion of a diaper before use, comprising a leakage barrier which is folded down and fastened to the side flap and the second surface layer, in a side view;
20

Fig. 3b shows a part of the front end portion of a diaper after use, comprising a leakage barrier which has come away from its fastening surface and become a standing or raised leakage barrier;
25

Fig. 4 shows a part of the front end portion of a diaper before use, comprising a leakage barrier which is folded down and fastened to the first surface layer,
30

Fig. 5a shows a part of the front end portion of a diaper before use, comprising a leakage barrier which is folded down and fastened to the second surface layer, and

5

Fig. 5b shows a part of the front end portion of a diaper before use, comprising a leakage barrier which is folded down and fastened to the first surface layer.

10 MODE(S) FOR CARRYING OUT THE INVENTION

The invention relates to all types of absorbent product intended to be placed in the crotch area of a wearer and to absorb bodily excretions. The invention therefore includes products such as diapers, pant diapers, incontinence pads or the like. It is principally a diaper which is described here.

The diaper shown in Figure 1 has a longitudinal centre line and a transverse centre line and has a front and a rear end portion 1, 2, an intermediate crotch portion 3, which is intended to be arranged between the legs of a wearer during use of the diaper, longitudinal side edges 4, 5 and transverse side edges 6, 7, a lower, liquid-impermeable backing layer 8, an absorption body 9, a first, liquid-permeable surface layer 10, and longitudinal leakage barriers 15, 16 fastened in the longitudinal direction along the liquid-permeable surface layer 10 on a first line 29 which constitutes or runs near to the first edge 45, 46 of the leakage barriers 15, 16. The leakage barriers 15, 16 also comprise a second edge 17, 18. The second edge 17, 18 contains elastic and is therefore gathered together at least in its central portion. Side flaps 11, 12 extend in the lateral direction outside the leakage barriers 15, 16 and, at least in the crotch portion 3, have longitudinal elastic elements 13, 14 along their free side edges 4, 5, which elastic elements 13, 14 serve as leg elastic during use of the product.

A first, essentially liquid-permeable surface layer 10 is positioned between the leakage barriers 15, 16, and a second, essentially liquid-impermeable surface layer 39 is positioned outside the leakage barriers 15, 16, the ends 5 15a, 15b, 16a, 16b of the leakage barriers being, in the example shown, folded down in the front end portion 1 and fastened flat against the first surface layer by a binder, for example glue or welding or the like, along a second line 28 which runs near to the second edge 17, 18 of the leakage barriers 15, 16 at least in part of the front end portion 1 and the rear end 10 portion 2. Alternatively, it is possible to fasten down the ends 15a, 15b, 16a, 16b of the leakage barriers 15, 16 in only one of the end portions 1, 2. It is also possible to fasten the ends 15a, 15b, 16a, 16b to the liquid-impermeable surface layer 39.

15 The leakage barriers 15, 16 also have a first surface 41, 42 and a second surface 43, 44 between the ends 15a, 15b, 16a, 16b. The surface layers 10, 39 can be two different layers or alternatively the surface layers 10, 39 can be one and the same layer, but with greater liquid-permeability within an area which in Fig. 1 corresponds to the surface of the liquid-permeable 20 surface layer 10. The diaper also comprises fastening arrangements 19, 20 (here folded in towards the surface layer of the diaper) in the form of tape with glue, or touch-and-close fasteners or the like. The diaper comprises side flaps 11, 12 which extend some way outside the leakage barriers.

25 The first edge 45, 46 of the leakage barriers 15, 16 is permanently fastened essentially along the liquid-permeable surface layer 10 on each side of the longitudinal centre line 38 of the diaper but can also be fastened throughout the areas 15a, 15b, 15c, 16a, 16b. The fastening is effected by, for example, gluing or welding. In the embodiment in Fig. 1, the second edge 17, 18 of the 30 leakage barriers is folded down outwards away from the longitudinal centre line 38 of the product near to the crotch portion 3 of the diaper, and the first

surface 41, 42 of the leakage barriers is fastened by a binder which loses its adhesive and/or cohesive capacity during use of the product.

Fig. 2 shows how the diaper will appear during use. Here, the front end portion 1 and the rear end portion 2 of the diaper can be seen, with the intermediate crotch portion 3. The front portion 1 is fastened together with the rear portion 2 by means of fastening arrangements 19, 20. This forms an opening 21 for the trunk of the wearer at the top of the diaper. An opening 22 for the leg of the wearer can also be observed in the figure. There is of course a corresponding leg opening 22 on that side of the diaper facing away from the observer in Figure 2. At the edge of the opening 22 for the leg of the wearer, which is delimited by a side edge 4 on the product, a side flap 11 and a raised leakage barrier 15 can be seen, the first surface 41 of the leakage barrier 15 appearing clearly as the binder in its fastening surface has lost its adhesive and/or cohesive capacity, and the leakage barrier 15 has as a result assumed the form of a raised leakage barrier.

The leakage barrier 15, 16 is gathered, at least in its central part, by elastic elements which are fastened in a pretensioned state to the second edge 17, 18 of the leakage barrier 15, 16 and fastened at its ends 15a, 15b, 16a, 16b to the surface layer 10, 39. This means that when the product is extended around the wearer, and the glue which holds the second edge 17, 18 of the leakage barrier folded down comes away from its fastening surface, the leakage barrier will stand up and form a raised leakage barrier against the body of the wearer. The elastic is tensioned during use, which results in the second edge 17, 18 of the leakage barrier 15, 16 being directed upwards towards the wearer.

The leakage barriers 15, 16 are preferably essentially liquid-impermeable in order to prevent liquid from leaking out, principally in the crotch portion 3. As mentioned above, it can be a problem in the product on a wearer that the

leakage barriers 15, 16 have a tendency to end up in the wrong place, that is to say to be folded in over the absorption body 9 and the surface layer 10 and thus to block these from the liquid and the motions discharged by the wearer. This problem is eliminated as, according to the invention, the second
5 edge 17, 18 of the leakage barriers 15, 16 is folded down, and the first surface 41, 42 or second surface 43, 44 of the leakage barriers is fastened to the first surface layer 10 and/or the second surface layer 39 preferably near to the crotch portion 3 by a binder which loses its adhesive and/or
cohesive capacity during use of the absorbent product. The leakage barriers
10 15, 16 are then raised.

The areas located laterally outside the leakage barriers 15, 16 and the first line 29 are considered to be the side flaps 11, 12. In the front end portion 1 and rear end portion 2 of the diaper, the front ends 23, 24 and rear ends 25,
15 26 of the side flaps 11, 12 can be seen. The waist elastic shown in the figures can be present on one or both of the transverse edges 6, 7, but it is also possible for the diaper to have no waist elastic.

Fig. 3a shows a part of a diaper before use, where the leakage barrier 15
20 shown and its stretchable second edge 17 are folded down near to the crotch portion 3 against the second surface layer 39, away from the longitudinal centre line 38 of the product. The first surface 41 of the leakage barrier 15 is fastened by a binder, which loses its adhesive and/or cohesive capacity during use, to the side flap 11 and the second surface layer 39 near
25 to the crotch portion 3.

In the cross-section of the diaper, the lower, liquid-impermeable backing layer 8, the absorption body 9 and the first, liquid-permeable surface layer 10 can be seen. A part of a longitudinal edge 4 and a transverse edge 6, a
30 part of a side flap 11, with longitudinal elastic elements 13, the front end 25 of a side flap, and the end 15a of the leakage barrier, which end is folded

down flat against the first surface layer 10, can also be seen. The second line 28 extends to a certain extent in the direction of the longitudinal centre line 38 of the product, the end 15a of the folded-down leakage barrier being fastened to the first surface layer 10 along this second line. The fastening is suitably effected by gluing or welding, for example ultrasonic welding. It is also possible for the entire area 15a, between the first line 29 and the second line 28, to be fastened to the first surface layer 10 in the same manner, or only the first line 29 or alternatively the first line 29 and the second line 28 can be fastened in the same manner.

10

Fig. 3b shows a part of the diaper after use. The leakage barrier 15 and its stretchable second edge 17 are in the raised position, the first surface 41 of the leakage barrier 15 having come away from the side flap 11 and the second surface layer 39. In the cross-section of the diaper, the lower, liquid-impermeable backing layer 8, the absorption body 9 and the first, liquid-permeable surface layer 10 can be seen. A part of a longitudinal edge 4 and a transverse edge 6, with longitudinal elastic elements 13, the front end 25 of a side flap, and the end 15a of the leakage barrier, which end is folded down flat against the first surface layer 10, can also be seen. A second line 28 extends to a certain extent in the direction of the longitudinal centre line 38 of the product, the end 15a of the folded-down leakage barrier being fastened to the first surface layer 10 along this second line. The fastening is suitably effected by gluing or welding, for example ultrasonic welding. It is also possible for the entire area 15a, between the first line 29 and the second line 28, to be fastened to the first surface layer 10 in the same manner. Alternatively, only the first line 29 or alternatively the first line 29 and the second line 28 can be fastened in the same manner.

It should be noted that Figs 4, 5a, and 5b show a different embodiment of the leakage barriers. This is in order to show that the invention is not limited to only one embodiment of leakage barriers but that all conceivable forms of

leakage barrier can and are to be included within the scope of the invention. To the extent that a reference relates to a similar part, the same reference number is used as before.

5 Fig. 4 shows another embodiment of the invention before use, where the leakage barrier 15 and its stretchable second edge 17 are folded down near to the crotch portion 3, away from the second surface layer 39 and towards the longitudinal centre line 38 of the product. The second surface 43 of the leakage barrier 15 is fastened by a binder, which loses its adhesive and/or
10 cohesive capacity during use, to the first surface layer 10 near to the crotch portion 3. In the cross-section of the diaper, the lower, liquid-impermeable backing layer 8, the absorption body 9 and the second, liquid-impermeable surface layer 39 can be seen. A part of a longitudinal edge 4 and a transverse edge 6, a part of a side flap 11, the front end 25 of a side flap,
15 and the end 15a of the leakage barrier, which end is folded down flat against the first surface layer 10, can also be seen. A second line 28 extends to a certain extent in the direction of the longitudinal centre line 38 of the product, the end 15a of the folded-down leakage barrier being fastened to the first surface layer 10 along this second line. The fastening is suitably effected by
20 gluing or welding, for example ultrasonic welding. It is also possible for the entire area 15a, between the first line 29 and the second line 28, to be fastened to the surface layer in the same manner, or the first line 29 or alternatively the first line 29 and the second line 28 can be fastened in the same manner.

25

Fig. 5a shows another embodiment of the invention before use, where the leakage barrier 15 and its stretchable second edge 17 are folded down against the second surface layer 39 near to the crotch portion 3, away from the longitudinal centre line 38 of the product. The first surface 41 of the
30 leakage barrier 15 is fastened by a binder, which loses its adhesive and/or cohesive capacity during use, away from the first surface layer 10, to the

side flap 11 near to the crotch portion 3. In the cross-section of the diaper, the lower, liquid-impermeable backing layer 8, the absorption body 9, the first, liquid-permeable surface layer 10 and the second, liquid-impermeable surface layer 39 can be seen. A part of a longitudinal edge 4 and a transverse edge 6, the front end 25 of a side flap, and the end 15c of the leakage barrier, which end is folded down flat away from the first surface layer 10, can also be seen. A second line 28 extends to a certain extent in the direction of the longitudinal centre line 38 of the product, the end 15c of the folded-down leakage barrier being fastened to the second surface layer 39 along this second line. The fastening is suitably effected by gluing or welding, for example ultrasonic welding. It is also possible for the entire area 15c, between the first line 29 and the second line 28, to be fastened to the second surface layer 39 in the same manner, or only the first line 29 or alternatively the first line 29 and the second line 28 can be fastened in the same manner.

Fig. 5b shows another embodiment of the invention before use, where the leakage barrier 15 and its stretchable second edge 17 are folded down against the first surface layer 10 near to the crotch portion 3, away from the longitudinal centre line 38 of the product. The second surface 43 of the leakage barrier 15 is fastened by a binder, which loses its adhesive and/or cohesive capacity during use, to the first surface layer 10, away from the side flap 11 near to the crotch portion 3.

In the cross-section of the diaper, the lower, liquid-impermeable backing layer 8, the absorption body 9, the first, liquid-permeable surface layer 10 and the second, liquid-impermeable surface layer 39 can be seen. A part of a longitudinal edge 4 and a transverse edge 6, the front end 25 of a side flap, and the end 15c of the leakage barrier, which end is folded down flat away from the first surface layer 10, can also be seen. A second line 28 extends to a certain extent in the direction of the longitudinal centre line 38

of the product, the end 15c of the folded-down leakage barrier being fastened to the second surface layer 39 along this second line. The fastening is suitably effected by gluing or welding, for example ultrasonic welding. It is also possible for the entire area 15c, between the first line 29
5 and the second line 28, to be fastened to the surface layer in the same manner. In a corresponding manner, only the first line 29 or alternatively the first line 29 and the second line 28 can be fastened in the same manner.

A fibre fabric material, a non-woven material, is usually used as a surface
10 layer in absorbent products, such as diapers and incontinence pads. It is also possible, however, to use perforated plastic film, net material, open-cell foam or the like. It is also possible to use absorption materials with a surface which also functions as a liquid-permeable surface layer. Examples of such absorption materials are absorbent open-cell foam, bound fibre wadding or
15 the like. A fibre fabric material which is often used as a surface material on absorbent products is fibre fabric made of polypropylene fibres. This material is hydrophobic, which means that, in the untreated state, it tends not to admit liquid. It is a suitable material for, for example, the leakage barriers 15, 16 and the surface layer 39 of the side flaps 11, 12, which are preferably liquid-
20 impermeable. The surface layer in a diaper can consist of the same material over the entire surface, both inside and outside the leakage barriers, as well as in the leakage barriers, which are then folded from the surface material with an elastic thread included as an elastic element which produces the gathered part of the leakage barriers.

25

Liquid will be admitted on the surface layer between the two leakage barriers 15, 16. The side flaps 11, 12, including their front and rear ends 23, 24, 25, 26, are located outside the leakage barriers 15, 16. As mentioned above, a fibre fabric made of polypropylene is hydrophobic and thus essentially liquid-
30 impermeable, which is suitable for the side flaps and the leakage barriers as these are preferably to be liquid-impermeable. In the liquid-receiving area

between the two leakage barriers 15, 16, it must be possible for liquid to penetrate in order to reach the absorption body 9. Here, the surface layer has been treated so that it is hydrophilic and thus tends to admit liquid and allow it through to the underlying absorption body 9. A fibre fabric made of
5 polypropylene can be treated in a conventional manner so that it becomes hydrophilic.

The first and second surface layers 10, 39 can consist of one and the same layer which extends over the entire diaper. Then, either the part which
10 constitutes the first surface layer 10 between the leakage barriers 15, 16 is treated so that it becomes liquid-permeable, or the part which constitutes the second surface layer 39 is treated so that it becomes essentially liquid-impermeable. The leakage barriers 15, 16 can also consist of this layer, consisting of the same material type or different material types. If the same
15 material type is used, the different layers 10, 39 can have, for example, a different fibre content so that the materials differ in terms of impermeability or thickness and allow liquid through to a greater or lesser extent. In this connection, a more impermeable material is then selected in the areas which are to be liquid-impermeable, that is to say the surface layer 39 of the side
20 flaps 11, 12 and their front and rear ends 23, 24, 25, 26 and, if appropriate, the leakage barriers 15, 16. A less impermeable material is used on the liquid-receiving surface layer 10 which is located between the two leakage barriers 15, 16. The materials can be hydrophobic or hydrophilic from the outset, and the hydrophobic material is selected where the material is to be
25 liquid-impermeable, and the hydrophilic material is selected where the material is to be liquid-permeable. The leakage barriers 15, 16 can also consist of a number of different layers. If the first layer is a fibre fabric made of, for example, spunbond non-woven, which is common today, a material layer can be applied by means of a meltblown technique, which layer is
30 liquid-impermeable, and then another layer of fibre fabric can be applied. In a meltblown technique, a molten polymer is extruded in a hot gas stream at

high speed, which transforms the polymer into fibres which are cooled and collected to form a fabric or web which is in this case then bound together with a web of fibre fabric. An example of such materials is what is known as SMS (spunbond-meltblown-spunbond) material. This type of layer material
5 can also be used as the surface layer 39 on the side flaps 11, 12 which are also essentially liquid-impermeable. Other types of liquid-impermeable material can of course also be used in these areas, in the same way as it is possible to use different liquid-permeable materials in the surface layer 10 between the leakage barriers 15, 16.

10

In the embodiment shown, the absorption body 9 consists of cellulose fluff with or without what are known as superabsorbent products mixed in. However, the absorption body can be made of any material(s) used in absorption bodies for absorbent products such as diapers, pant diapers,
15 incontinence pads, panty liners or the like. The absorption body 9 can also consist of more than one layer of absorbent material and can also contain layers of wadding material or the like so as to be capable of conducting discharged liquid away from the liquid-receiving surface layer 10 rapidly. Each of the layers comprised by the absorption body 9 can of course contain
20 superabsorbents.

The liquid-impermeable backing layer 8 can consist of or comprise a liquid-impermeable plastic film, a non-woven layer coated with a liquid-blocking material, or some other flexible material layer which has the capacity to
25 resist liquid penetration. It is in general an advantage if the liquid-impermeable backing layer 8 is breathable, that is to say allows water vapour to pass through the layer 8.

The invention therefore relates to an absorbent product with improved
30 characteristics with regard to the positioning of the leakage barriers 15, 16 and the design for putting the product on the wearer. The leakage barriers

15, 16 and their stretchable second edge 17, 18 are folded down away from and/or towards the longitudinal side edge 4, 5 of the product towards and/or away from the longitudinal centre line 38 of the product, the first surface 41, 42 and/or second surface 43, 44 of the leakage barriers 15, 16 are fastened 5 there near to the side flaps 11, 12 and the first surface layer 10 and/or second surface layer 39 near to the crotch portion 3 by a binder which loses its adhesive and/or cohesive capacity during use of the product. The folding down of the leakage barriers 15, 16 eliminates the risk of the leakage barriers positioning themselves over the liquid-permeable surface layer 10 10 and thus preventing bodily fluids and motions from the wearer from reaching the absorption body 9, the risk of leakage of bodily fluids, motions, unpleasant sensations and skin irritations on account of close contact with motions etc. being avoided.

PATENT CLAIMS

1. Absorbent product, such as a diaper, a pant diaper, an incontinence pad, a sanitary towel or the like, comprising an absorption body (9) having a generally oblong shape with two longitudinal sides (4, 5), two transverse sides (6, 7), a longitudinal centre line (38), and also comprising a first, liquid-permeable surface layer (10) and a second, essentially liquid-impermeable surface layer (39), an essentially liquid-impermeable backing layer (8), an absorption body (9) positioned between said liquid-permeable surface layer (10) and said backing layer (8), two leakage barriers (15, 16) made of flexible material in the longitudinal direction on each side of the longitudinal centre line (38) and the liquid-permeable surface layer (10), each of the leakage barriers (15, 16) having a first edge (45, 46) permanently fastened along the liquid-permeable surface layer (10) and a second edge (17, 18) which extends in the direction of the longitudinal centre line (38) of the absorbent product, each of the leakage barriers (15, 16) also having a first surface (41, 42) and a second surface (43, 44), characterized in that the first surface (41, 42) and/or the second surface (43, 44) of each said leakage barrier (15, 16) is fastened to or near to the first, liquid-permeable surface layer (10) and/or the second, liquid-impermeable surface layer (39).

2. Product according to Claim 1, wherein the first surface (41, 42) and/or second surface (43, 44) of each said leakage barrier (15, 16) is temporarily fastened by a binder which loses its adhesive and/or cohesive capacity during use of the absorbent product, wherein the first surface (41, 42) and/or second surface (43, 44) of each leakage barrier (15, 16) then comes away from its fastening surface and forms a raised leakage barrier.

3. Product according to either of the preceding claims, wherein the binder loses its adhesive and/or cohesive capacity within the temperature range 30-37°C.

4. Product according to any one of the preceding claims, wherein the binder is oil, wax or glue.
5. Product according to any one of the preceding claims, wherein the binder comprises glycerides and/or C₁₄-C₂₂ fatty alcohols and/or C₁₂-C₂₂ fatty acids and/or C₁₂-C₂₂ fatty alcohol ethoxylates with a degree of ethoxylation of roughly 2 to roughly 30 and/or derivatives thereof.
6. Product according to any one of the preceding claims, wherein the binder is a glue.
7. Product according to any one of the preceding claims, whereas the binder is a mixture of saturated and unsaturated C₁₂-C₂₂ fatty acids.
8. Product according to any one of the preceding claims, wherein the binder loses its adhesive and/or cohesive capacity at TEWL values above 20 g/m²h.
9. Product according to any one of the preceding claims, wherein the leakage barriers (15, 16) comprise a non-woven material or laminate thereof.
10. Product according to any one of the preceding claims, wherein the binder is constituted by ultrasonic welding and/or a thermal bond.

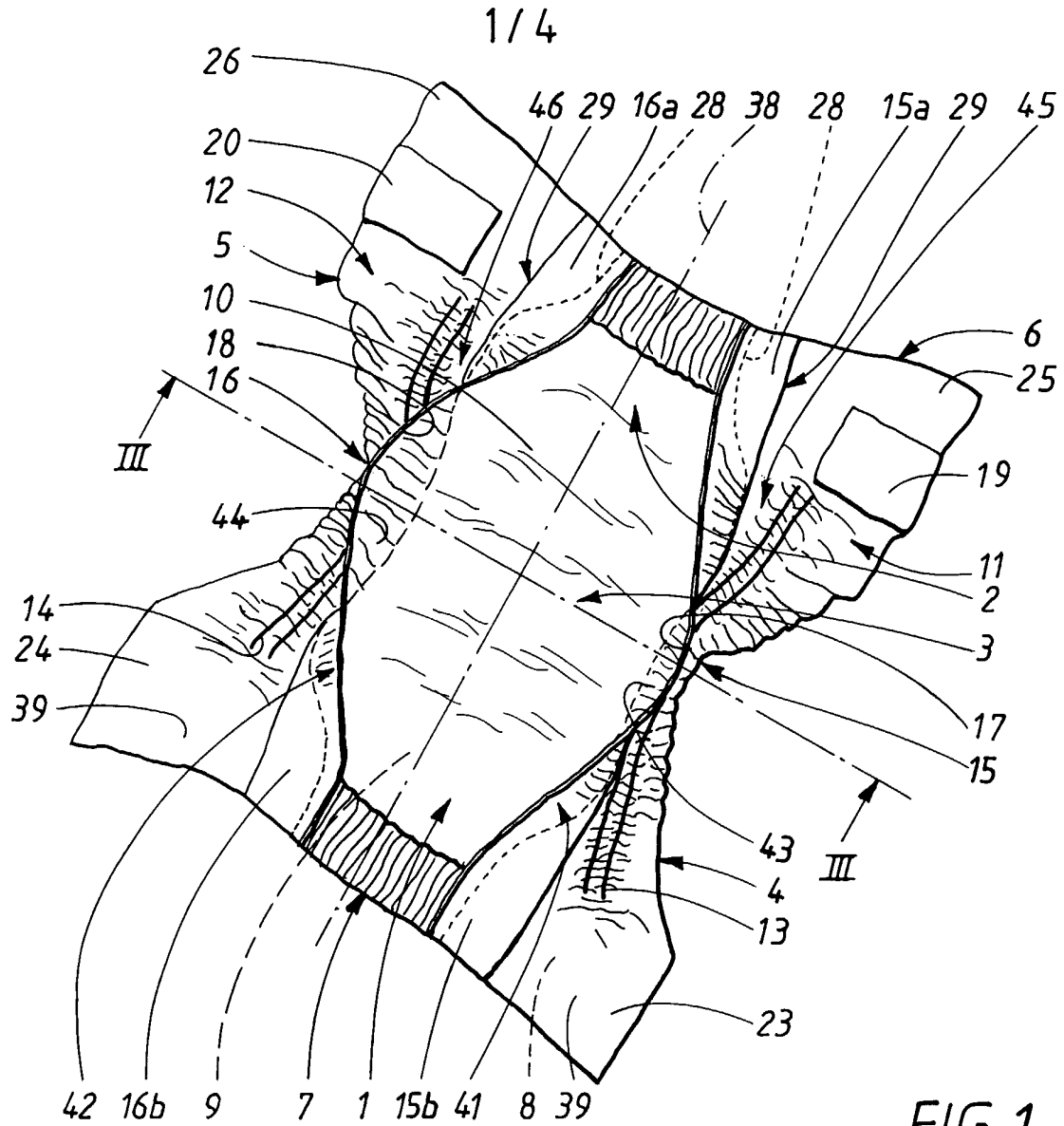

FIG. 1

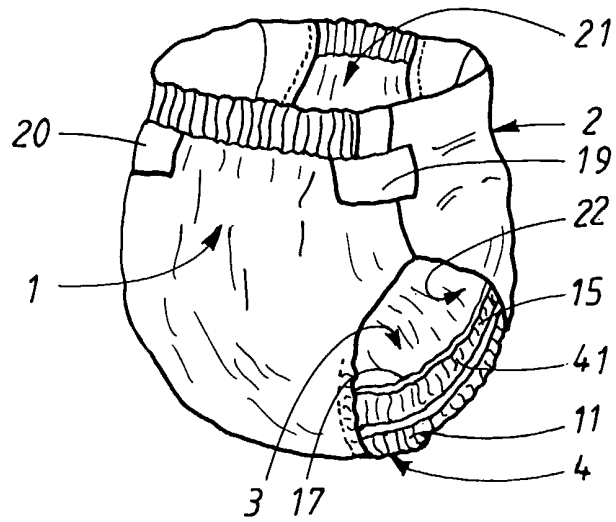

FIG. 2

2/4

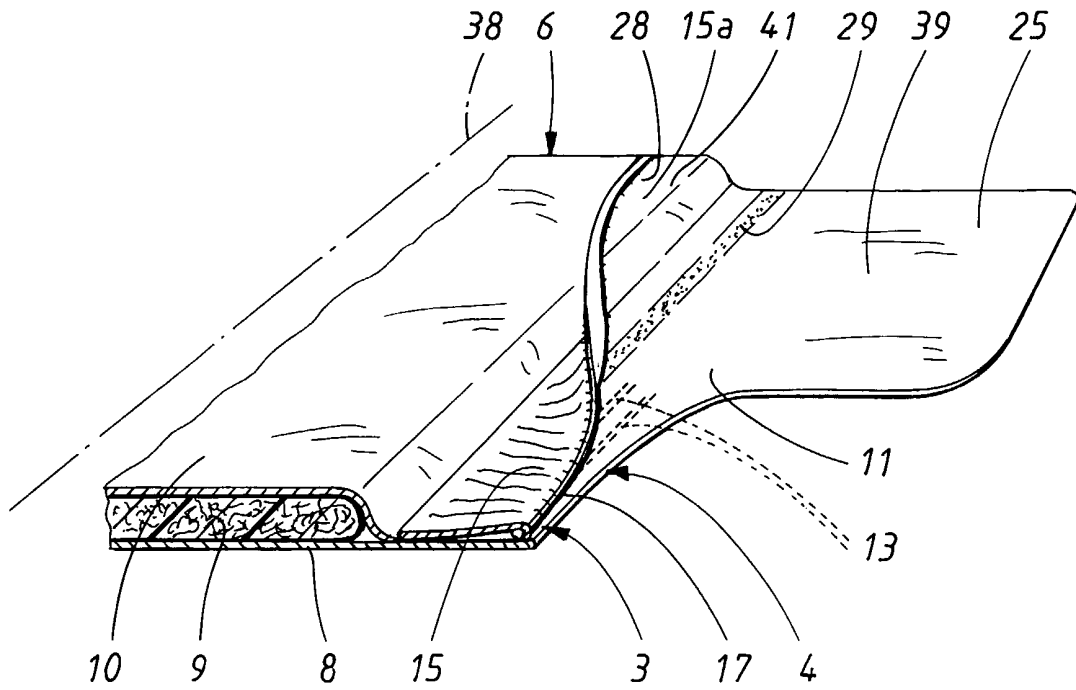

FIG. 3a

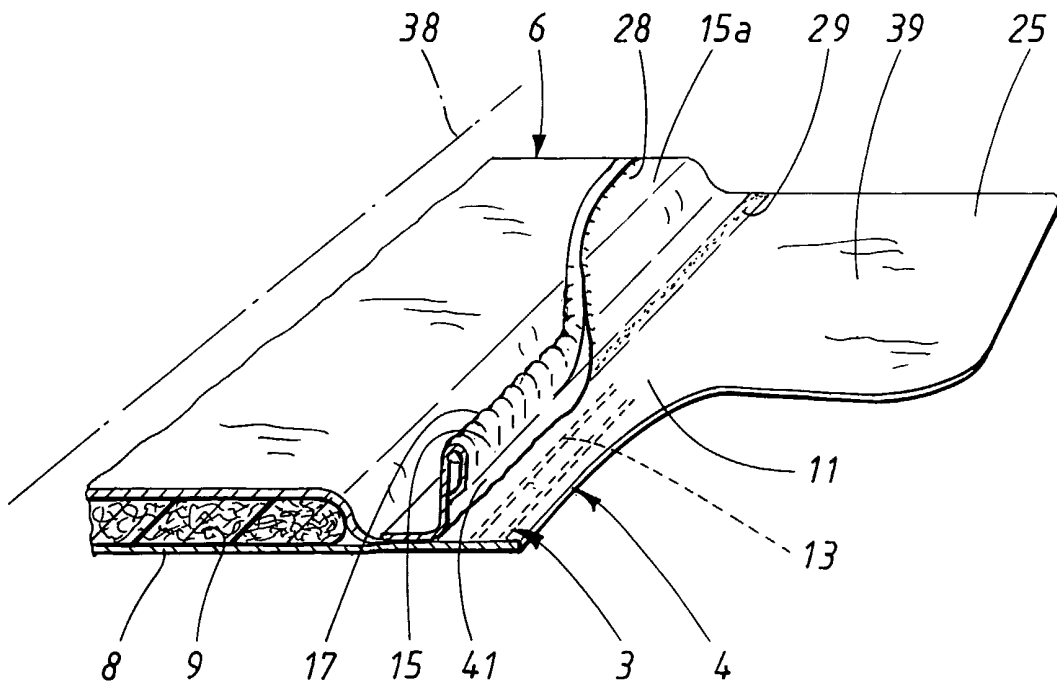

FIG. 3b

3/4

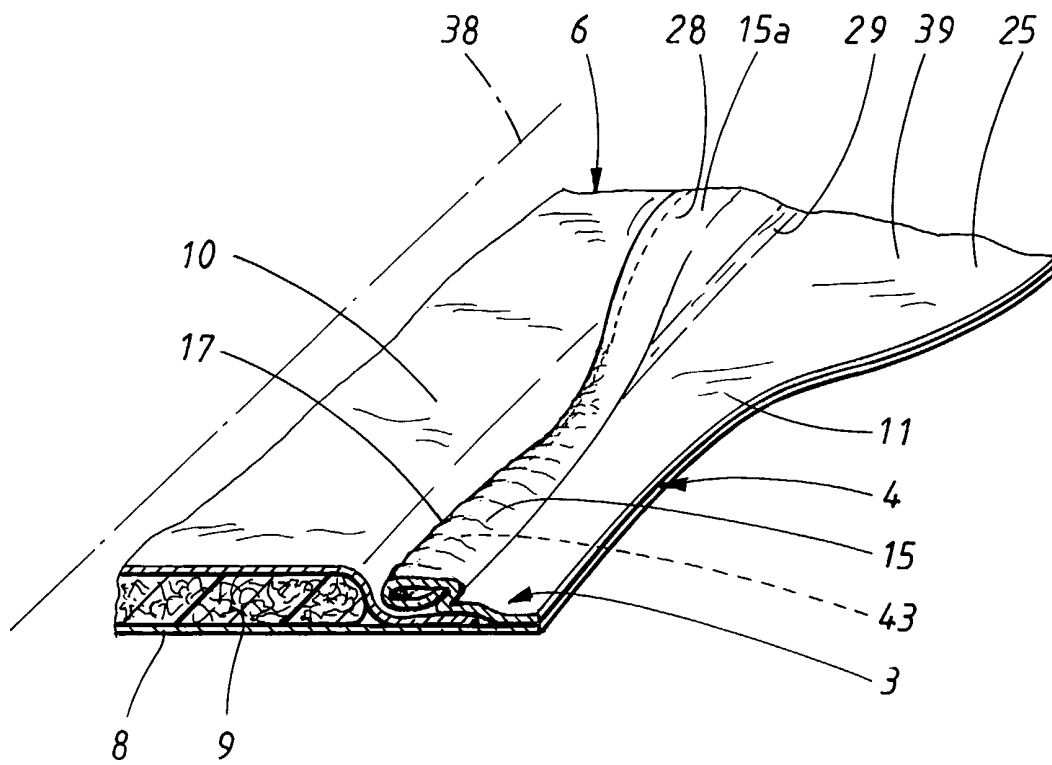

FIG.4

4/4

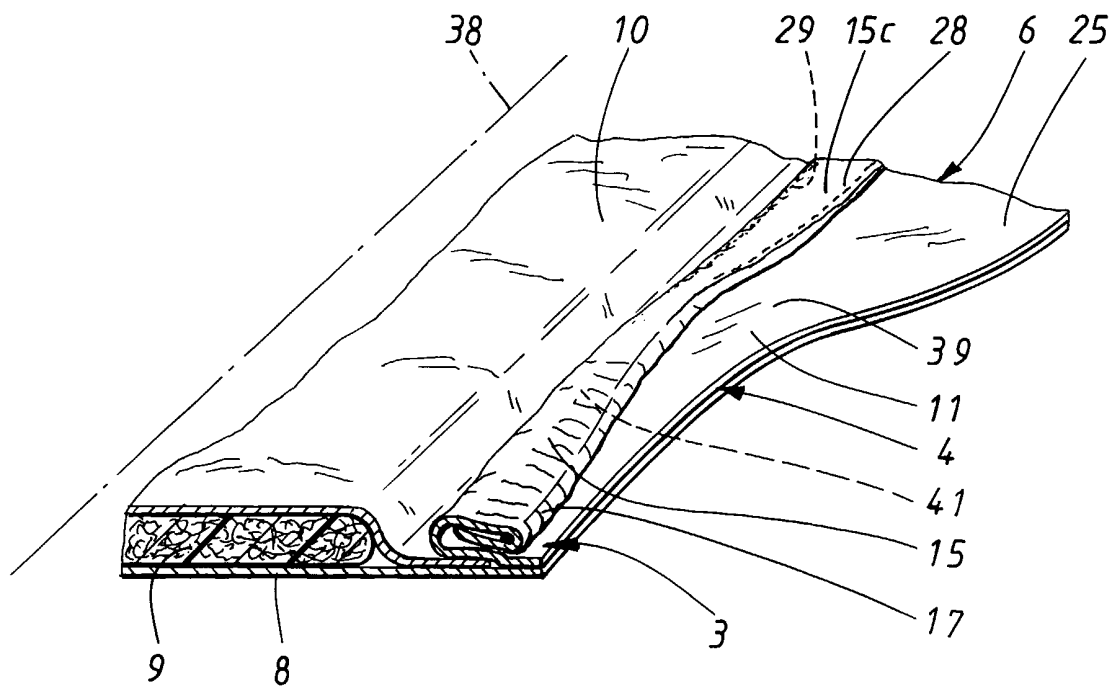

FIG. 5a

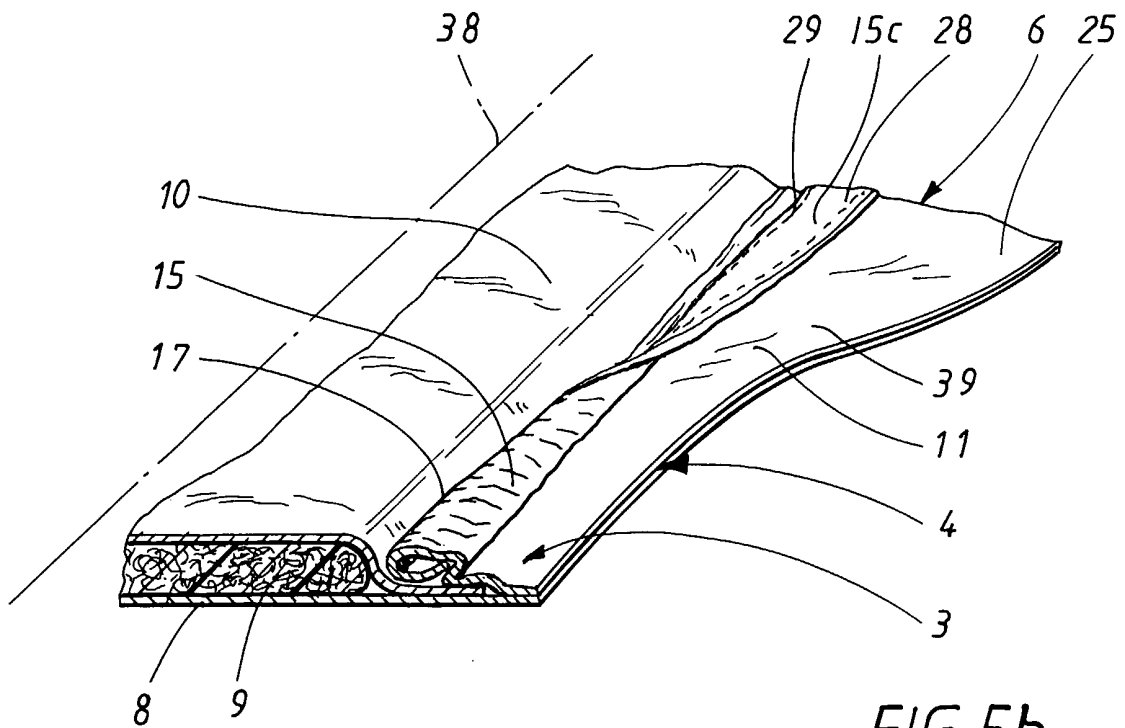

FIG. 5b

INTERNATIONAL SEARCH REPORT

International application No.
PCT/SE 01/02717

A. CLASSIFICATION OF SUBJECT MATTER

IPC7: A61F 13/15

According to International Patent Classification (IPC) or to both national classification and IPC

B. FIELDS SEARCHED

Minimum documentation searched (classification system followed by classification symbols)

IPC7: A61F

Documentation searched other than minimum documentation to the extent that such documents are included in the fields searched

SE,DK,FI,NO classes as above

Electronic data base consulted during the international search (name of data base and, where practicable, search terms used)

WPI, PAJ, FULLTEXT, INSPEC, EPOQUE

C. DOCUMENTS CONSIDERED TO BE RELEVANT

Category*	Citation of document, with indication, where appropriate, of the relevant passages	Relevant to claim No.
X	US 4904251 A (TAKAMITSU IGAUE ET AL), 27 February 1990 (27.02.90), column 9, line 9 - line 27, figure 19	1-2,9-10
Y	--	3-8
Y	US 4822435 A (TAKAMITSU IGAUE ET AL), 18 April 1989 (18.04.89), column 4, line 36 - line 51, figures 7,9,18	3-8
	-- -----	

Further documents are listed in the continuation of Box C. See patent family annex.

* Special categories of cited documents:

- "A" document defining the general state of the art which is not considered to be of particular relevance
- "E" earlier application or patent but published on or after the international filing date
- "L" document which may throw doubts on priority claim(s) or which is cited to establish the publication date of another citation or other special reason (as specified)
- "O" document referring to an oral disclosure, use, exhibition or other means
- "P" document published prior to the international filing date but later than the priority date claimed

- "T" later document published after the international filing date or priority date and not in conflict with the application but cited to understand the principle or theory underlying the invention
- "X" document of particular relevance: the claimed invention cannot be considered novel or cannot be considered to involve an inventive step when the document is taken alone
- "Y" document of particular relevance: the claimed invention cannot be considered to involve an inventive step when the document is combined with one or more other such documents, such combination being obvious to a person skilled in the art
- "&" document member of the same patent family

Date of the actual completion of the international search

28 February 2002

Date of mailing of the international search report

02-04-2002

Name and mailing address of the ISA/
Swedish Patent Office
Box 5055, S-102 42 STOCKHOLM
Facsimile No. +46 8 666 02 86

Authorized officer

Beata Słusarczyk/EIs
Telephone No. +46 8 782 25 00

INTERNATIONAL SEARCH REPORT

Information on patent family members

28/01/02

International application No.

PCT/SE 01/02717

Patent document cited in search report			Publication date	Patent family member(s)	Publication date
US	4904251	A	27/02/90	NONE	
US	4822435	A	18/04/89	AU	596231 B 26/04/90
				AU	8016387 A 28/04/88
				BR	8705718 A 31/05/88
				CA	1300572 A 12/05/92
				DE	3773619 A 14/11/91
				EP	0268858 A,B 01/06/88
				SE	0268858 T3
				ES	2028028 T 01/07/92
				GB	2196834 A,B 11/05/88
				JP	2035964 C 28/03/96
				JP	7067475 B 26/07/95
				JP	63190002 A 05/08/88
				KR	9508166 B 26/07/95
				PH	24668 A 07/09/90
				JP	1875025 C 26/09/94
				JP	4067866 B 29/10/92
				JP	63112706 A 17/05/88