



(51) International Patent Classification:

F01D 25/04 (2006.01) *F01D 25/24* (2006.01)
F04D 29/66 (2006.01) *F03B 11/02* (2006.01)
F04D 29/40 (2006.01)

(21) International Application Number:

PCT/US2018/020880

(22) International Filing Date:

05 March 2018 (05.03.2018)

(25) Filing Language:

English

(26) Publication Language:

English

(30) Priority Data:

62/466,774 03 March 2017 (03.03.2017) US
62/501,852 05 May 2017 (05.05.2017) US

(71) Applicant: ELLIOTT COMPANY [US/US]; 901 North Fourth Street, Jeannette, Pennsylvania 15644 (US).

(72) Inventor: KUSHNER, Francis; 55 Circle Drive, Delmont, Pennsylvania 15626 (US).

(74) Agent: BYRNE, Richard, L. et al.; The Webb Law Firm, One Gateway Center, 420 Ft. Duquesne Blvd., Suite 1200, Pittsburgh, Pennsylvania 15222 (US).

(81) Designated States (unless otherwise indicated, for every kind of national protection available): AE, AG, AL, AM, AO, AT, AU, AZ, BA, BB, BG, BH, BN, BR, BW, BY, BZ, CA, CH, CL, CN, CO, CR, CU, CZ, DE, DJ, DK, DM, DO, DZ, EC, EE, EG, ES, FI, GB, GD, GE, GH, GM, GT, HN, HR, HU, ID, IL, IN, IR, IS, JO, JP, KE, KG, KH, KN, KP, KR, KW, KZ, LA, LC, LK, LR, LS, LU, LY, MA, MD, ME, MG, MK, MN, MW, MX, MY, MZ, NA, NG, NI, NO, NZ, OM, PA, PE, PG, PH, PL, PT, QA, RO, RS, RU, RW, SA, SC, SD, SE, SG, SK, SL, SM, ST, SV, SY, TH, TJ, TM, TN, TR, TT, TZ, UA, UG, US, UZ, VC, VN, ZA, ZM, ZW.

(84) Designated States (unless otherwise indicated, for every kind of regional protection available): ARIPO (BW, GH, GM, KE, LR, LS, MW, MZ, NA, RW, SD, SL, ST, SZ, TZ, UG, ZM, ZW), Eurasian (AM, AZ, BY, KG, KZ, RU, TJ, TM), European (AL, AT, BE, BG, CH, CY, CZ, DE, DK, EE, ES, FI, FR, GB, GR, HR, HU, IE, IS, IT, LT, LU, LV, MC, MK, MT, NL, NO, PL, PT, RO, RS, SE, SI, SK, SM,

(54) Title: METHOD AND ARRANGEMENT TO MINIMIZE NOISE AND EXCITATION OF STRUCTURES DUE TO CAVITY ACOUSTIC MODES

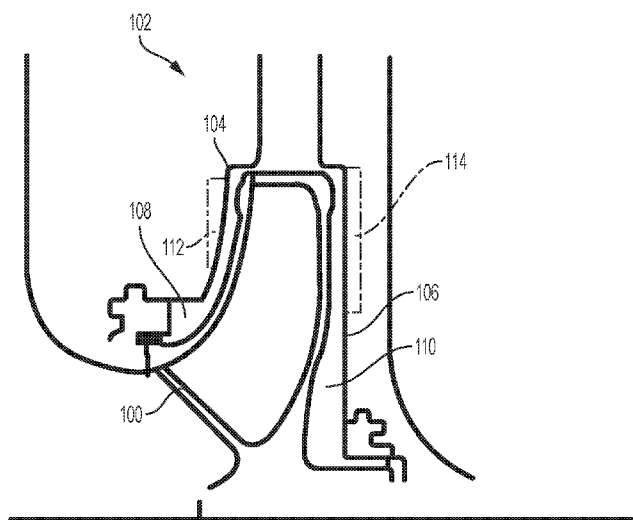

FIG. 3

(57) Abstract: An arrangement for intentionally mistuning a cavity formed adjacent an impeller in a turbomachine, the arrangement including at least two bladed elements defined within a perimeter of a casing wall adjacent the impeller, wherein the bladed elements are configured to mistune cavity acoustic modes to minimize acoustic pulsations in the cavity.



TR), OAPI (BF, BJ, CF, CG, CI, CM, GA, GN, GQ, GW,
KM, ML, MR, NE, SN, TD, TG).

Published:

— *with international search report (Art. 21(3))*

METHOD AND ARRANGEMENT TO MINIMIZE NOISE AND EXCITATION OF STRUCTURES DUE TO CAVITY ACOUSTIC MODES

CROSS REFERENCE TO RELATED APPLICATIONS

[0001] This application claims the benefit of U.S. Provisional Patent Nos. 62/466,774 and 62/501,852, filed on March 3, 2017 and May 5, 2017, respectively, the disclosures of which are hereby incorporated in their entireties by reference.

BACKGROUND OF THE INVENTION

Field of the Invention

[0002] The present disclosure relates, generally to turbomachines and other mechanisms and, more particularly, to blade-like element arrangements for cavities within a turbomachine adapted for reducing rotor disk excitation using intentional mistuning.

Description of Related Art

[0003] Turbomachines, such as centrifugal flow compressors, axial flow compressors, and turbines may be utilized in various industries. Centrifugal flow compressors and turbines, in particular, have a widespread use in power stations, jet engine applications, gas turbines, and automotive applications. Centrifugal flow compressors and turbines are also commonly used in large-scale industrial applications, such as air separation plants and hot gas expanders used in the oil refinery industry. Centrifugal compressors are further used in large-scale industrial applications, such as refineries and chemical plants.

[0004] With reference to **FIG. 1**, a multi-stage, centrifugal-flow turbomachine **10** is illustrated in accordance with a conventional design. In some applications, a single stage may be utilized. In other applications, multiple stages may be utilized. Such a turbomachine **10** generally includes a shaft **20** supported within a housing **30** by a pair of bearings **40**. Turbomachine **10** shown in **FIG. 1** includes a plurality of stages to progressively increase the fluid pressure of the working fluid. Each stage is successively arranged along the longitudinal axis of turbomachine **10** and all stages may or may not have similar components operating on the same principle.

[0005] With continued reference to **FIG. 1**, an impeller **50** includes a plurality of rotating blades **60** circumferentially arranged and attached to an impeller hub **70** which is in turn attached to shaft **20**. Blades **60** may be optionally attached to a cover disk **65**. A plurality of impellers **50** may be spaced apart in multiple stages along the axial length of shaft **20**. Rotating blades **60** are

fixedly coupled to impeller hub **70** such that rotating blades **60** along with impeller hub **70** rotate with the rotation of shaft **20**. Rotating blades **60** rotate downstream of a plurality of stationary vanes or stators **80** attached to a stationary tubular casing. The working fluid, such as a gas mixture, enters and exits turbomachine **10** in the axial direction of shaft **20**. Energy from the working fluid causes a relative motion of rotating blades **60** with respect to stators **80**. In a centrifugal compressor, the cross-sectional area between rotating blades **60** within impeller **50** decreases from an inlet end to a discharge end, such that the working fluid is compressed as it passes across impeller **50**.

[0006] Referring to **FIG. 2**, working fluid, such as a gas mixture, moves from an inlet end **90** to an outlet end **100** of turbomachine **10**. A row of stators **80** provided at inlet end **90** channels the working fluid into a row of rotating blades **60** provided at outlet end **100** of turbomachine **10**. Stators **80** extend within the casing for channeling the working fluid to rotating blades **60**. Stators **80** are spaced apart circumferentially with equal spacing between individual struts around the perimeter of the casing. A diffuser **110** is provided at the outlet of rotating blades **60** for homogenizing the fluid flow coming off rotating blades **60**. Diffuser **110** optionally has a plurality of diffuser vanes **120** extending within a casing. Diffuser blades **120** are spaced apart circumferentially, typically with equal spacing between individual diffuser blades **120** around the perimeter of the diffuser casing. In a multi-stage turbomachine **10**, a plurality of return channel vanes **125** are provided at outlet end **100** of a fluid compression stage for channeling the working fluid to rotating blades **60** of the next successive stage. In such an embodiment, the return channel vanes **125** provide the function of stators **80** from the first stage of turbomachine **10**. The last impeller in a multi-stage turbomachine typically only has a diffuser, which may be provided with or without the diffuser vanes. The last diffuser channels the flow of working fluid to a discharge casing (volute) having an exit flange for connecting to the discharge pipe. In a single-stage embodiment, turbomachine **10** includes stators **80** at inlet end **90** and diffuser **110** at outlet end **100**.

[0007] An important concern in designing turbomachines is controlling the vibration of the rotating blades and the hub throughout the operating range of the turbomachine. Rotating blades and disks in turbomachinery are excited into resonant vibrations by a) upstream stator strut and/or vane wakes and potential flow interaction with downstream struts and vanes, b) other inhomogeneities in the flow stream formed by non-uniform circumferential pressure distribution,

c) acoustic pulsations either at rotating blade passing frequency and/or d) vortex shedding from stationary vanes, in turn causing coincident acoustic resonance of the gas within the casing. For example, Tyler/Sofrin modes may occur due to sound waves at blade passing frequency reflecting off vanes giving spinning modes. (Ref. Tyler, J. M., and Sofrin, T. G., 1962, "Axial Flow Compressor Noise Studies", SAE Transactions, Vol.70, pp.309-332.) The acoustic pulsations at the spinning mode in turn can match the mode shape and frequency of the acoustic mode of the cavity at the sides of the impeller, and also match the mode of the impeller structure. This is termed triple coincidence. The acoustic pulsations reflect differently off of the stator struts set back further from the impeller and reduce the effective amplitude of the spinning modes. For example, in an impeller having 15 rotating blades and 20 stator struts, there is a 5-diameter spinning mode at blade passing frequency 15 times the rotor speed. If the 5-diameter structural mode is equal to 20 times the rotating speed, the blade excitation can be lowered by setting half of the stator struts downstream about one-half an acoustic wave length, as wave reflections would result in phase cancellation. One example of such an arrangement is disclosed in U.S. Patent No. 9,581,034.

[0008] These excitations cause cyclic stress, resulting in potentially high cycle fatigue and failure in impellers either at rotating blades, the hub, or the cover. The impeller can be excited to a large amplitude when a modal frequency corresponds to shaft rotational frequency multiplied by the harmonic number of the flow inhomogeneity seen by the blades. Typically, the number of resonances with an amplitude large enough to cause high cycle fatigue is limited. Since the damage rate from fatigue occurs only if infinite endurance strength of the material is breached, a modest reduction in the vibration amplitude often will eliminate high cycle fatigue as the limiting factor for blade and disk life.

[0009] If a critical resonance cannot be avoided, one current practice to overcome these problems is to avoid operation at the resonant frequency by changing the speed rapidly when a resonance is encountered, thereby minimizing the number of fatigue cycles that a blade accumulates during operation. If the number of vibration cycles is minimized, then blade failure is controlled by mechanisms other than downstream wakes, acoustic pulsations, flow inhomogeneities, or vortex shedding. However, this practice places undesirable limits on operation of turbomachinery.

[0010] Another current approach is to reduce the spatial variations in the flow field by directly injecting fluid into low-velocity wakes behind obstructions (Rao, N. M., Feng, J., Burdisso, R. A, and Ng, W. F., "Active Flow Control to Reduce Fan Blade Vibration and Noise", 5^{sup}.th AIAA/CEAS Aeroacoustic Conference, American Institute of Aeronautics and Astronautics, May 10-12, 1999). This approach requires the use of either fluid from the compressor or from an additional external fluid source in relatively large quantities. Use of compressor fluid has a detrimental impact on performance. The addition of a separate fluid supply adds weight and requires additional power. Both methods have detrimental impacts on performance of the turbomachinery. Also, wake filling does not address modal excitation due to bow waves from downstream flow obstructions.

[0011] In recent years, it has been discovered that besides non-uniform flow excitation, such as from stator wakes, acoustic pressure pulsation can be a concern at least for high pressure centrifugal compressor impellers. This has been termed "triple coincidence" and explains rare failures and likely a reason, at least partially, for some previous undocumented failures. Bladed disk interaction resonance can be avoided for centrifugal impellers as needed, depending on vibratory mode involved, available damping, and potential excitation level. Especially for stages having vanes in the diffuser near impeller tips, concern for high cycle fatigue is very high as certain numbers of vanes combined with a number of rotating blades can give a correct phase to excite a highly responding mode. A similar but more complex interaction is with transverse acoustic modes having a specific number of nodal diameters. In this case, acoustic gas modes in cavities at sides of impellers, matching rotating acoustic pulsations at impeller blade passing frequency termed Tyler/Sofrin modes, and a matching structural impeller mode give the triple coincidence causing higher resonant response of the impeller, besides increased noise. The concern for this coincidence is often difficult to evaluate and to correct unless there is a known failure to modify number of vanes or blades. This coincidence can add to the direct response from either upstream wakes or downstream diffuser vane interacting flow pulsations. Dimensions of impeller side cavities are axisymmetric and are set by aerodynamics, so that outer and inner radii define transverse modes with small radial dimensional changes available. Often a minor aerodynamic performance compromise can be used to change designs to avoid serious resonances, e.g. numbers of vanes and blades, changing the response of a matching diameter mode or have a different less responsive mode to alleviate concern. Besides turbomachinery, e.g.

compressors and pumps, the methods as described could be utilized for any cavity that has diametrical mode shapes, or possibly other patterns of pressure pulsation frequencies. These modification(s) can alleviate if not eliminate concern for any mechanism having structural vibration and/or environmental noise issues.

SUMMARY OF THE INVENTION

[0012] In one aspect of the disclosure, an arrangement for intentionally mistuning a cavity formed adjacent an impeller hub and/or another cavity formed when there is an impeller cover on a turbomachine having “n”-diameter acoustic modes includes at least two bladed elements defined within a perimeter of a casing wall adjacent the impeller. The bladed elements are configured to mistune the cavities to minimize acoustic pulsations in the cavity.

[0013] In another aspect, two times “n” bladed elements may be defined in the casing wall, wherein “n” is the n-diameter cavity mode that is to be mistuned. The bladed elements may be grooves or ridges defined in the casing wall. For example, of an n-diameter mode where “n”=5, at least 20 bladed elements may be defined in the casing wall. Ten bladed elements may have a depth greater than the other ten adjacent bladed elements. Ten bladed elements may have a width greater than the other ten adjacent bladed elements. The bladed elements may be spaced equidistant from one another. The bladed elements may be defined in the casing wall on a hub side of the impeller. The bladed elements may be defined in the casing wall on a cover side of the impeller.

[0014] In another aspect, a turbomachine includes a casing having an inlet end opposite an outlet end along a longitudinal axis of the casing, a shaft assembly provided within the casing, the shaft assembly extending from the inlet end to the outlet end, a rotor having a plurality of rotating impellers extending radially outward from the shaft assembly, and at least two bladed elements defined within a perimeter of the casing adjacent one of the impellers. The bladed elements are configured to mistune at least one cavity adjacent to the impeller to minimize acoustic pulsations in the cavity for an n-diameter mode.

[0015] In another aspect, the bladed elements may be grooves or ridges defined in the casing wall. At least ten bladed elements may be defined in the casing wall. Five bladed elements may have a depth greater than the other five bladed elements. Five bladed elements may have a width greater than the other five bladed elements. The bladed elements may be spaced equidistant from one another. The bladed elements may be defined in the casing wall on a hub side of the

impeller. The bladed elements may be defined in the casing wall on a cover side of the impeller. At least sixteen bladed elements may be defined in the casing wall with a specific harmonic mistuning pattern.

[0016] In another aspect, up to one less than four times “n” bladed elements may be defined in the casing wall, where “n” is the n-diameter cavity mode that is to be mistuned. The bladed elements may be defined in the casing wall on a hub side of the impeller. The bladed elements may be defined in the casing wall on a cover side of the impeller. The bladed elements may vary in a linear pattern from minimum to maximum size around the circumference to mistune the cavities to minimize acoustic pulsations in the cavity. In another aspect, the number of bladed elements can be selected from two up to one less than $2 \times “n”$. For example, if the mode is a 5-diameter mode, then $(2n-1)$ or nine bladed elements can be selected to mitigate or eliminate the 5-diameter mode within the area containing the bladed elements. If needed, the nine vanes can still be mistuned to give a $2 \times “n”$ harmonic or other mistuning pattern to reduce noise and/or impeller vibration.

[0017] This invention is also defined by the following clauses:

[0018] Clause 1: An arrangement for intentionally mistuning a cavity formed adjacent an impeller hub and/or another cavity formed when an impeller cover is provided in a turbomachine having “n”-diameter acoustic modes, the arrangement comprising: at least two bladed elements defined within a perimeter of a casing wall adjacent a hub side of the impeller, wherein the bladed elements are configured to mistune the cavities to minimize acoustic pulsations in the cavity.

[0019] Clause 2: The arrangement as recited in Clause 1, wherein the bladed elements are grooves or ridges defined in the casing wall.

[0020] Clause 3: The arrangement as recited in Clause 2, wherein at least ten bladed elements are defined in the casing wall.

[0021] Clause 4: The arrangement as recited in Clause 3, wherein two times “n” bladed elements have a depth greater than the other two times “n” bladed elements.

[0022] Clause 5: The arrangement as recited in Clause 3 or 4, wherein two times “n” bladed elements have a width greater than the other two times “n” bladed elements.

[0023] Clause 6: The arrangement as recited in any of Clauses 2-5, wherein the bladed elements are spaced equidistant from one another.

[0024] Clause 7: The arrangement as recited in any of Clauses 1-6, wherein the bladed elements are defined in the casing wall on a cover side of the impeller.

[0025] Clause 8: The arrangement as recited in any of Clauses 1-7, wherein the bladed elements are provided in at least one of in-phase and out-of-phase with one another in the casing wall and/or at least one of in-phase and out-of-phase on the sides of the impeller hub and a cover.

[0026] Clause 9: The arrangement as recited in any of Clauses 2-8, wherein at least eight bladed elements are defined in the casing wall with a specific harmonic mistuning pattern.

[0027] Clause 10: The arrangement as recited in any of Clauses 1-9, wherein $(2n-1)$ bladed elements are defined in one or more of the cavities with or without a mistuning pattern.

[0028] Clause 11: The arrangement as recited in any of Clauses 1-10, wherein bladed elements are defined in one or more of the cavities to mistune an acoustic mode with opposite phase to the structural mode of the rotating element.

[0029] Clause 12: A turbomachine having “n”-diameter acoustic modes, comprising: a casing having an inlet end opposite an outlet end along a longitudinal axis of the casing; a shaft assembly provided within the casing, the shaft assembly extending from the inlet end to the outlet end; a rotor having a plurality of rotating impellers with or without covers extending radially outward from the shaft assembly; and at least two bladed elements defined within a perimeter of the casing adjacent one of the impellers on a hub side of the casing, wherein the bladed elements are configured to mistune at least one cavity adjacent to the impeller to minimize acoustic pulsations in the cavity.

[0030] Clause 13: The turbomachine as recited in Clause 12, wherein the bladed elements are grooves or ridges defined in the casing wall.

[0031] Clause 14: The turbomachine as recited in Clause 13, wherein at least four times “n” bladed elements are defined in the casing wall.

[0032] Clause 15: The turbomachine as recited in Clause 14, wherein two times “n” bladed elements have a depth greater than the other two times “n” bladed elements.

[0033] Clause 16: The turbomachine as recited in Clause 14 or 15, wherein two times “n” bladed elements have a width greater than the other two times “n” bladed elements.

[0034] Clause 17: The turbomachine as recited in any of Clauses 13-16, wherein the bladed elements are spaced equidistant from one another.

[0035] Clause 18: The turbomachine as recited in any of Clauses 12-17, wherein the bladed elements are defined in the casing wall on a hub side of the impeller.

[0036] Clause 19: The turbomachine as recited in any of Clauses 12-18, wherein the bladed elements are defined in the casing wall on a cover side of the impeller.

[0037] Clause 20: The turbomachine as recited in any of Clauses 12-19, wherein the bladed elements are provided in at least one of in-phase and out-of-phase with one another in the casing wall and/or at least one of in-phase and out-of-phase on the sides of the impeller hub and a cover.

[0038] Clause 21: The turbomachine as recited in any of Clauses 13-20, wherein at least eight bladed elements are defined in the casing wall.

[0039] Clause 22: A cavity in a gas- or liquid-handling mechanism with mistuning modifications as recited in any of Clauses 1-11.

[0040] These and other features and characteristics of the turbomachine, as well as the methods of operation and functions of the related elements of structures and the combination of parts and economies of manufacture, will become more apparent upon consideration of the following description and the appended claims with reference to the accompanying drawings, all of which form a part of this specification, wherein like reference numerals designate corresponding parts in the various figures. It is to be expressly understood, however, that the drawings are for the purpose of illustration and description only and are not intended as a definition of the limits of the invention. As used in the specification and the claims, the singular form of “a”, “an”, and “the” include plural referents unless the context clearly dictates otherwise.

BRIEF DESCRIPTION OF THE DRAWINGS

[0041] FIG. 1 is a partial-cutaway perspective view of a multi-stage, centrifugal-flow turbomachine in accordance with a prior art embodiment;

[0042] FIG. 2 is a schematic cross-sectional view of one stage of the turbomachine shown in FIG. 1;

[0043] FIG. 3 is a schematic cross-sectional view of one stage of a turbomachine according to the present disclosure;

[0044] FIG. 4 is a front perspective view of an impeller and a cover disk according to the present disclosure;

[0045] FIG. 5 is a rear perspective view of the impeller and the cover disk of FIG. 4;

[0046] FIG. 6 is a cross-sectional view of the casing wall of FIG. 3 showing a configuration of the blade-like elements according to an aspect of the disclosure;

[0047] FIG. 7 is a front view of the casing wall of FIG. 3 showing another configuration of the blade-like elements according to an aspect of the disclosure;

[0048] FIG. 8 is a front view of a casing wall including a ten slot arrangement; and

[0049] FIG. 9 is a front view of a casing wall including a twenty slot arrangement.

DESCRIPTION OF THE DISCLOSURE

[0050] For purposes of the description hereinafter, the terms “upper”, “lower”, “right”, “left”, “vertical”, “horizontal”, “top”, “bottom”, “lateral”, “longitudinal”, and derivatives thereof shall relate to the invention as it is oriented in the drawing figures. However, it is to be understood that the invention may assume alternative variations and step sequences, except where expressly specified to the contrary. It is also to be understood that the specific devices and processes illustrated in the attached drawings, and described in the following specification, are simply exemplary embodiments of the invention. Hence, specific dimensions and other physical characteristics related to the embodiments disclosed herein are not to be considered as limiting.

[0051] As described above, rotating blades or impellers **60** in a conventional turbomachine **10** are excited into resonant vibrations by a) upstream stator strut and/or vane wakes and potential flow interaction with downstream struts and vanes, b) other inhomogeneities in the flow stream formed by non-uniform circumferential pressure distribution, c) acoustic pulsations either at rotating blade passing frequency, multiples of blade passing frequency, and/or from vortex shedding from struts or vanes, in turn causing coincident acoustic resonance of the gas within the casing. Rotating blades or impellers **60** can be excited to a large amplitude when a blade modal frequency corresponds to the shaft rotational frequency multiplied by the harmonic number of the flow inhomogeneity seen by the rotating blade or impeller **60**.

[0052] The present disclosure is directed to a method of reducing cavity noise to both reduce noise signature, as well as potential excitation of adjacent bladed disks or impellers from acoustic pressure pulsations. The method considers cavities adjacent the impeller as equivalent gas-filled disks with boundary conditions at the sides and ends of the cavities. Acoustic modes within cavities are affected by the swirling flow of the gas within the cavities, differently on the cover side versus the hub side of the turbomachine. By adding blade-like elements to replace the

basic smooth boundaries of the cavities, an effective disk with blades can be modified with intentional mistuning to greatly reduce the response of vibratory modes of the gas in the cavities.

[0053] With reference to FIG. 3, an impeller 100 is housed within a casing 102 within a turbomachine, such as the turbomachine 10 shown in FIGS. 1 and 2. FIG. 3 illustrates a single stage of a turbomachine; however, one of ordinary skill in the art will understand that specific components illustrated in FIG. 3 can be easily adapted for use in multi-stage turbomachines, such as a multi-stage, centrifugal-flow compressor. A plurality of impellers 100 may be spaced apart in multiple stages along the axial length of the shaft. The impeller 100 is configured to rotate about the shaft during operation of the turbomachine. In one aspect, the impeller 100 is fixedly coupled to the shaft such that the impeller 100 rotates with the rotation of the shaft. The casing 102 may extend around a cover side 104 of the impeller 100 and a hub side 106 of the impeller 100. It is also contemplated that a cover may not be provided with the turbomachine, thereby providing an “open” impeller configuration. A first cavity 108 is defined on the cover side 104 of the impeller 100 and a second cavity 110 is defined on the hub side 106 of the impeller 100. In one aspect, the cavities 108, 110 are considered to be equivalent to gas-filled disks provided on the sides of the impeller 100. In one aspect, at least one cavity 108, 110 is modified so that the surface boundaries of the gas contained within the cavity 108, 110 has blade-like elements 112, 114. In another aspect, both cavities 108, 110 are modified so that the surface boundaries of the contained gas within the cavities 108, 110 have blade-like elements 112, 114 (also referred to as “bladed elements”). In one aspect, the blade-like elements 112, 114 are non-axisymmetric blade-like elements.

[0054] With reference to FIG. 3, in one aspect, the blade-like elements 112, 114 are grooves and/or ridges spaced around the circumference of the cavities 108, 110. In another aspect, the blade-like elements 112, 114 may be ribs that extend into the cavity. In another aspect, a machining process produces a wave-like length (also referred to as a scallop shape) that is spaced and subsequently modified to give a desired number of effective mistuned elements in the cavities 108, 110 to greatly reduce the response of vibratory modes of the gas in the cavities 108, 110. The number of blade-like elements 112, 114 can be chosen in order to apply desired variations to reduce a response of a particular diameter mode or modes. When referring to a diameter mode, it to be understood to mean a configuration of high acoustic pressure pulsations separated by areas having low acoustic pressure pulsations. For example, a 5-diameter acoustic

mode would have five areas with high acoustic pressure pulsations alternating with five areas having low acoustic pressure pulsations. Therefore, with reference to **FIG. 8**, five of the blade-like elements **112** may have a high acoustic pressure pulsation and the adjacent blade-like elements **112** may have low acoustic pressure pulsations. For example, a 5-diameter acoustic mode of the gases within the cavities **108**, **110** could be resonant with 15 times the operating speed, the impeller rotating blade passing frequency. The spinning modes for blade passing frequency could have five lobes due to 15 impellers interacting with 20 inlet vanes **80** or 20 diffuser vanes **120**. With a spinning acoustic mode at frequency ω with “n” patterns, there may be a variation of pressure in the circumferential direction that is continuous and repeats every 2π radians, as defined by the cylindrical geometry. This pressure distribution rotates at (ω / n) and generates, at every stationary point, a fluctuating pressure at frequency ω . The pattern sweeps the cavity annulus walls at a velocity $(r \times \omega / n)$, in which r is the radius of the cavity. One or both of the cavities **108**, **110** on the cover side **104** and the hub side **106** could have 10 equally-distant blade-like elements **112**, **114**, such as grooves and/or ridges, machined in the vertical walls of the casing **102**. It is also contemplated that alternative degrees of separation between the blade-like elements **112**, **114** may be used. Intentional mistuning can then be selected to give, for example, a 10-diameter mismatch pattern to greatly reduce the response of vibratory modes of the gas in the cavities **108**, **110**. In one aspect, to provide the intentional mistuning, a pattern with 20 blade-like elements **112**, **114**, such as grooves and/or ridges, would give a 10-diameter pattern or, alternatively, could have every second groove in the pattern twice as deep and/or wide as the adjacent groove, as shown in **FIGS. 6** and **7**. It is to be understood that the configuration of the blade-like elements **112** shown in **FIGS. 6** and **7** can also be used for the blade-like elements **114** on the hub side **106** of the impeller **100**. In another aspect, the configuration of the blade-like elements **112** on the cover side **104** of the impeller **100** could be different from the configuration of the blade-like elements **114** on the hub side **106** of the impeller **100**. In another aspect, a pattern could have 20 blade-like elements **112**, **114**, such as grooves, ridges, and/or scallop shapes. Using these patterns of blade-like elements **112**, **114**, acoustic pulsations are reduced and impeller response at 20 times speed is minimized.

[0055] If needed, the number of blade-like elements **112**, **114** to mistune may be chosen depending on whether the harmonic of the stationary vanes is greater than or less than the harmonic of the rotating blades. In an example where the harmonic of vanes is greater than the

harmonic of the blades passing by with $2 \times "n"$ blade-like elements **112**, **114**, the spinning modes due to interaction with the rotating blade passing frequency will rotate in an opposite direction to that from the stationary vanes and cancel some of the pulsations. For example, if the 5-diameter mode is due to the difference of 20 stationary vanes and 15 rotating blades, then 10 blade-like elements **112**, **114** would be used so that spinning modes would be in an opposite direction from those for the 20 stationary vanes. The acoustic pulsations due to the blade-like elements **112**, **114** would counter those caused by the vanes. In an example where the number of stationary vanes is less than the number of rotating blades, four times " n " blade-like elements **112**, **114** would be used. For example, if the 5-diameter mode is due to the difference of 10 stationary vanes and 15 rotating blades, 20 blade-like elements **112**, **114** would be used so that spinning modes would rotate in opposite directions from those for the ten stationary vanes. The acoustic pulsations due to blade-like elements **112**, **114** would counter those caused by the vanes. As an example of the present disclosure, shown in **FIG. 8**, the blade-like elements **112** may be milled into the upstream and downstream diaphragms on the surface of the cavity between the diaphragm and the impeller. In this example, ten blade-like elements **112** are spaced equally around the circumference. In this example, five larger blade-like elements **112** are spaced 72 degrees apart from one another. Smaller blade-like elements **112** are spaced equally between each of the larger blade-like elements **112**. Each blade-like element **112** may be 1.25 inches in length located at an inner radius of 4.875 inches. The larger blade-like elements **112** may be 0.5 inches wide and 0.25 inches deep. The smaller blade-like elements **112** may be 0.25 inches wide and 0.125 inches in depth. **FIG. 9** a similar arrangement of blade-like elements **112**. However, this arrangement includes twenty blade-like elements **112**, including ten larger blade-like elements **112** and ten smaller blade-like elements **112**. It is also to be understood that the blade-like elements **114** may be arranged in similar arrangements as described above.

[0056] In another aspect, by including the blade-like elements **112**, **114** within one of the cavities **108**, **110**, concern for circular modes are eliminated by having a different number of blade-like elements **112**, **114** than the rotating blades in the adjacent disk. Even 1-diameter modes that are of less concern structurally could have blade-like elements **112**, **114** to reduce acoustic pulsations. In other aspects, the blade passing frequency pulsations at the sides of the disks excite plate modes with high motion near the outer diameter of the disk. In this aspect, the

blade-like elements **112, 114** within the cavities **108, 110** are spaced and modified depending on the relative phase angles of the acoustic pulsations versus the plate mode.

[0057] Modifications to one or both of the cavities **108, 110** can be separate to reduce response of disks to one or more gas modes, but the modifications can also be in addition to structural bladed disk mistuning as is used in the prior art for even greater reliability. In particular, along with the blade-like elements **112, 114** provided on the casing **102**, similar blade-like elements, such as grooves, ridges, and/or scallop-shaped protrusions, could be provided on the disk or cover **65** of the impeller **100** facing the cavities **108, 110** to further reduce response. Alternatively, these could serve as the blade-like elements that mistune the adjacent fluid-filled cavities. It is to be understood that the term “fluid” used throughout this description encompasses gases, liquids, and gas/liquid mixtures. Acoustic modes would thus be affected by changes in the swirling flow of the gas within the cavities, differently on the cover side versus the hub side of the turbomachine. Cavity modifications could use direct machining and/or welding to form the blade-like element **112, 114** on the casing **102** or utilize inserts that can be installed and replaced in the cavities **108, 110** if needed. The blade-like elements **112, 114** may be worn down during use of the turbomachine and may need to be reformed or redefined. It is also contemplated that further blade-like elements could be added to the cavities **108, 110** to have other function within the cavities **108, 110**, such as reducing swirl of flow into seals in the turbomachine, reducing thrust load, or reducing flow point when the compressor or turbomachine stall begins at the impeller tip or diffuser entrance.

[0058] In other aspects, beside compressor impellers, the blade-like element arrangement may be used to mistune any cavity or annulus that has diametrical mode shapes or other pattern pressure pulsation frequency, excited by various sources, alleviating concern for structures, including rotating and stationary components, and/or environmental noise issues. Similar liquid-handling pumps, axial compressors, fans, as well as steam or gas turbines, are turbomachines that could utilize this disclosed method. Other potential applications for the mistuned blade-like element arrangement to reduce response of acoustic modes include fluid-handling including air mechanisms, such as engines, machinery, fuel cells, piping, ducts, diffusers, nozzles, valves, silencers, mufflers, seals, heat exchangers, airframes, tires and wheels, rockets, combustion chambers, vehicles, speakers, and double-pane windows.

[0059] With reference to **FIGS. 4** and **5**, blade-like elements **112** are defined in a diaphragm wall **118** adjacent to a cover disk **120** on the cover side of the impeller **100** in the turbomachine. In one aspect, two diaphragms **122a**, **122b** define cavities to receive the impeller **100**. The blade-like elements **112** may be defined in the diaphragm wall **118** of one or both of the diaphragms **122a**, **122b**. One or more blade-like elements **116** are circumferentially spaced around the diaphragm wall **118**. In another aspect, 20 blade-like elements **112** are defined in each diaphragm **122a**, **122b** at the sides of the impeller **100**. In one aspect, the blade-like elements **112** are separated 18 degrees apart from one another. As some acoustic modes are coupled to one another, both cavities and/or the impeller sides could have blade-like elements that are located out-of-phase with each other to provide additional mistuning.

[0060] While several aspects of the turbomachine and blade-like elements are shown in the accompanying figures and described in detail hereinabove, other aspects will be apparent to, and readily made by, those skilled in the art without departing from the scope and spirit of the disclosure. Accordingly, the foregoing description is intended to be illustrative rather than restrictive. The invention described hereinabove is defined by the appended claims and all changes to the invention that fall within the meaning and range of equivalency of the claims are to be embraced within their scope.

THE INVENTION CLAIMED IS:

1. An arrangement for intentionally mistuning a cavity formed adjacent an impeller hub and/or another cavity formed when an impeller cover is provided in a turbomachine having “n”-diameter acoustic modes, the arrangement comprising:

at least two bladed elements defined within a perimeter of a casing wall adjacent a hub side of the impeller,

wherein the bladed elements are configured to mistune the cavities to minimize acoustic pulsations in the cavity.

2. The arrangement as claimed in claim 1, wherein the bladed elements are grooves or ridges defined in the casing wall.

3. The arrangement as claimed in claim 2, wherein at least ten bladed elements are defined in the casing wall.

4. The arrangement as claimed in claim 3, wherein two times “n” bladed elements have a depth greater than the other two times “n” bladed elements.

5. The arrangement as claimed in claim 3, wherein two times “n” bladed elements have a width greater than the other two times “n” bladed elements.

6. The arrangement as claimed in claim 2, wherein the bladed elements are spaced equidistant from one another.

7. The arrangement as claimed in claim 1, wherein the bladed elements are defined in the casing wall on a cover side of the impeller.

8. The arrangement as claimed in claim 1, wherein the bladed elements are provided in at least one of in-phase and out-of-phase with one another in the casing wall and/or at least one of in-phase and out-of-phase on the sides of the impeller hub and a cover.

9. The arrangement as claimed in claim 2, wherein at least eight bladed elements are defined in the casing wall with a specific harmonic mistuning pattern.

10. The arrangement as claimed in claim 1, wherein $(2n-1)$ bladed elements are defined in one or more of the cavities with or without a mistuning pattern.

11. The arrangement as claimed in claim 1, wherein bladed elements are defined in one or more of the cavities to mistune an acoustic mode with opposite phase to the structural mode of the rotating element.

12. A turbomachine having “ n ”-diameter acoustic modes, comprising:
a casing having an inlet end opposite an outlet end along a longitudinal axis of the casing;

a shaft assembly provided within the casing, the shaft assembly extending from the inlet end to the outlet end;

a rotor having a plurality of rotating impellers with or without covers extending radially outward from the shaft assembly; and

at least two bladed elements defined within a perimeter of the casing adjacent one of the impellers on a hub side of the casing,

wherein the bladed elements are configured to mistune at least one cavity adjacent to the impeller to minimize acoustic pulsations in the cavity.

13. The turbomachine as claimed in claim 12, wherein the bladed elements are grooves or ridges defined in the casing wall.

14. The turbomachine as claimed in claim 13, wherein at least four times “ n ” bladed elements are defined in the casing wall.

15. The turbomachine as claimed in claim 14, wherein two times “ n ” bladed elements have a depth greater than the other two times “ n ” bladed elements.

16. The turbomachine as claimed in claim 14, wherein two times “n” bladed elements have a width greater than the other two times “n” bladed elements.

17. The turbomachine as claimed in claim 13, wherein the bladed elements are spaced equidistant from one another.

18. The turbomachine as claimed in claim 12, wherein the bladed elements are defined in the casing wall on a hub side of the impeller.

19. The turbomachine as claimed in claim 12, wherein the bladed elements are defined in the casing wall on a cover side of the impeller.

20. The turbomachine as claimed in claim 12, wherein the bladed elements are provided in at least one of in-phase and out-of-phase with one another in the casing wall and/or at least one of in-phase and out-of-phase on the sides of the impeller hub and a cover.

21. The turbomachine as claimed in claim 13, wherein at least eight bladed elements are defined in the casing wall.

22. A cavity in a gas- or liquid-handling mechanism with mistuning modifications as claimed in claim 1.

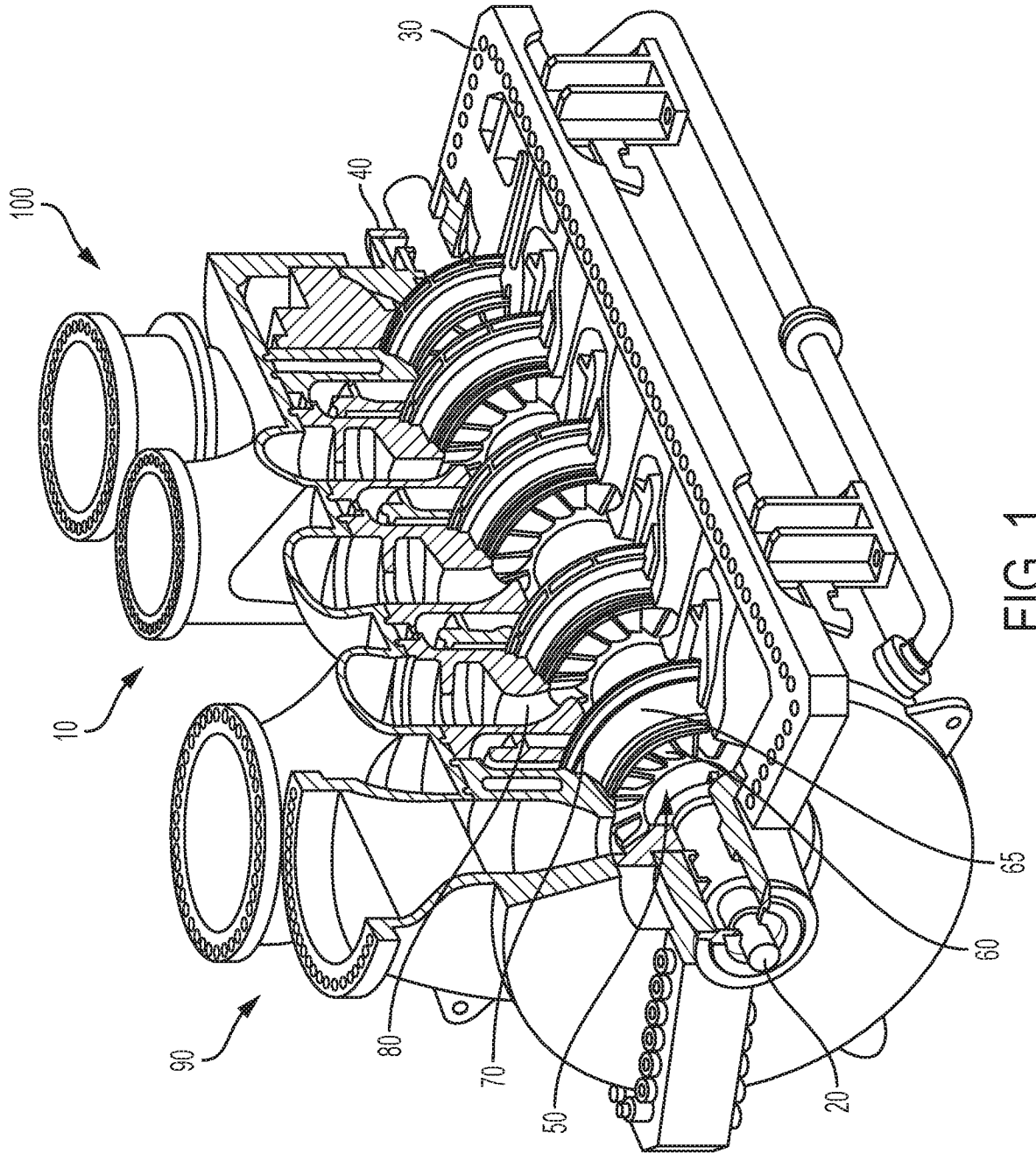

FIG. 1
PRIOR ART

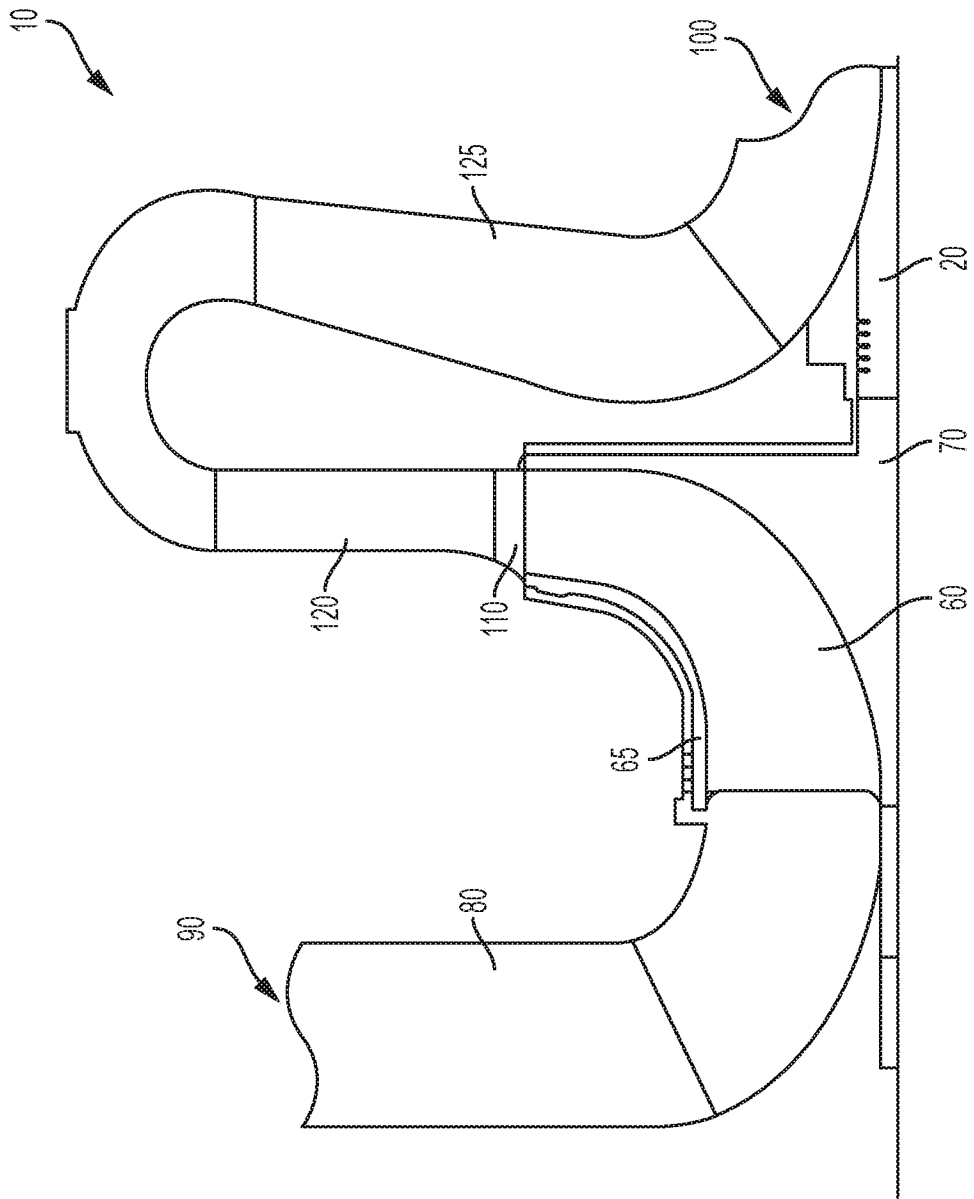

FIG. 2
PRIOR ART

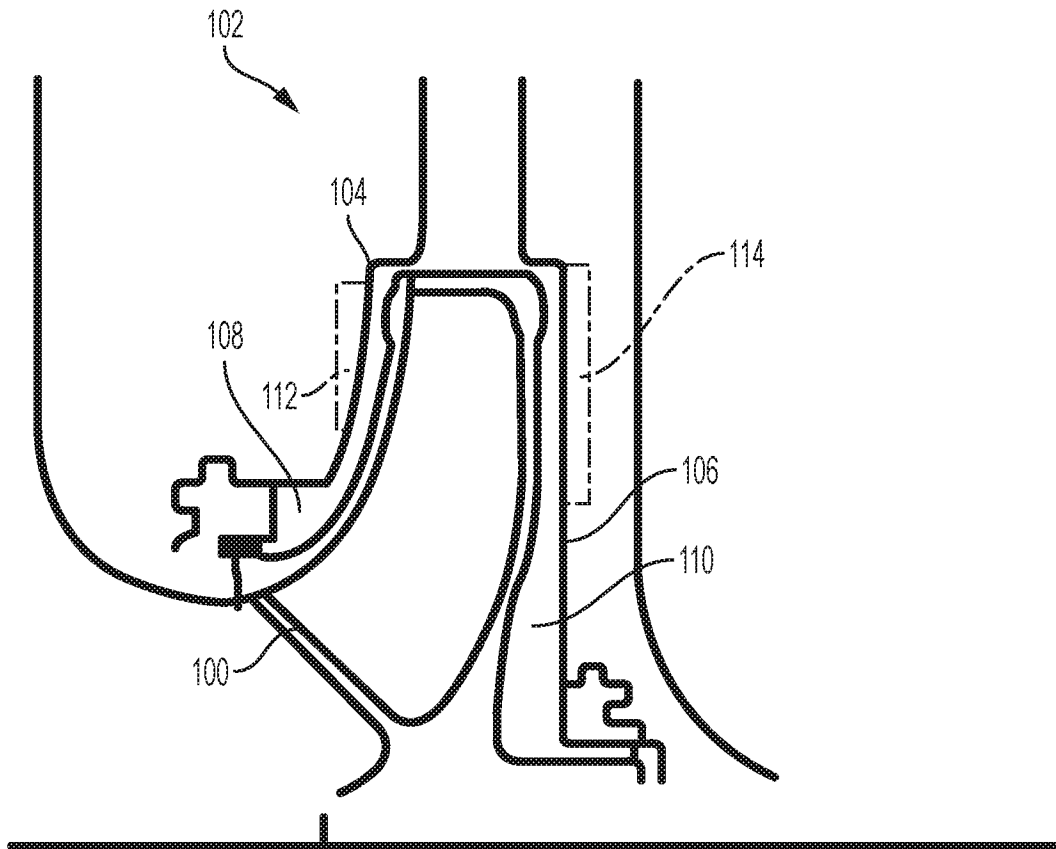

FIG. 3

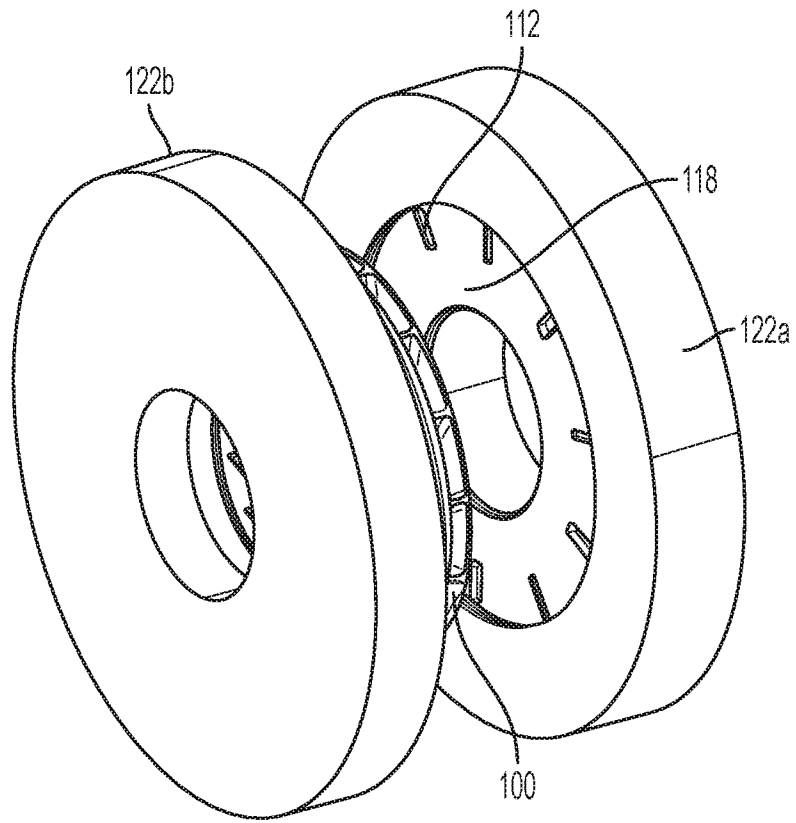

FIG. 4

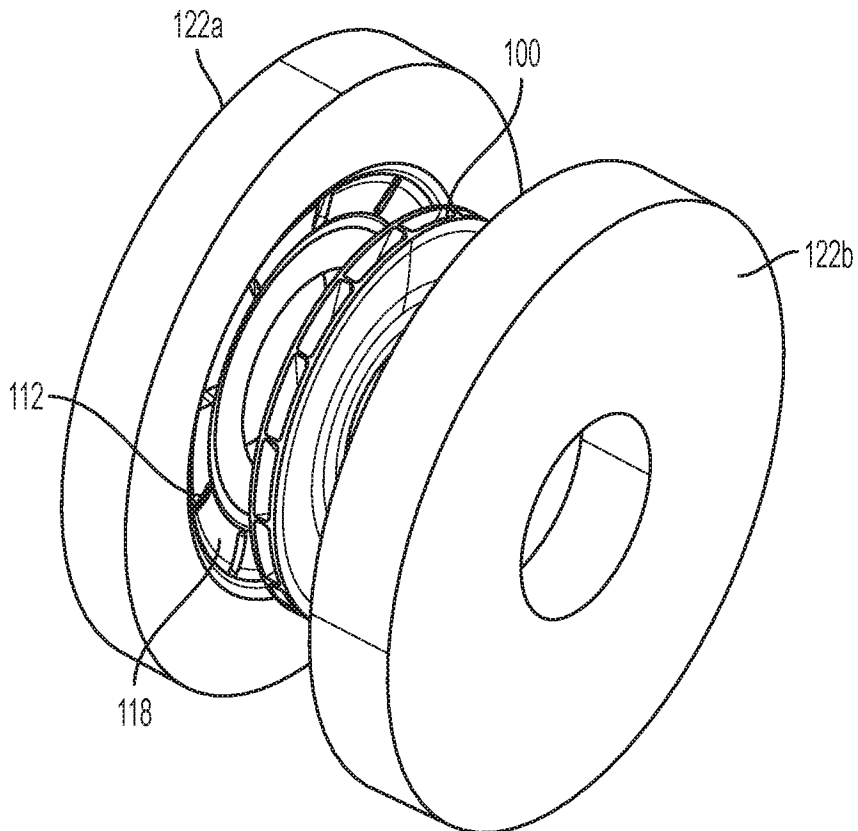

FIG. 5

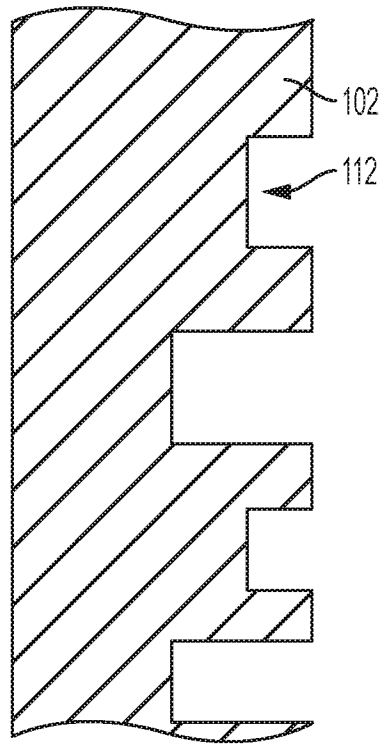

FIG. 6

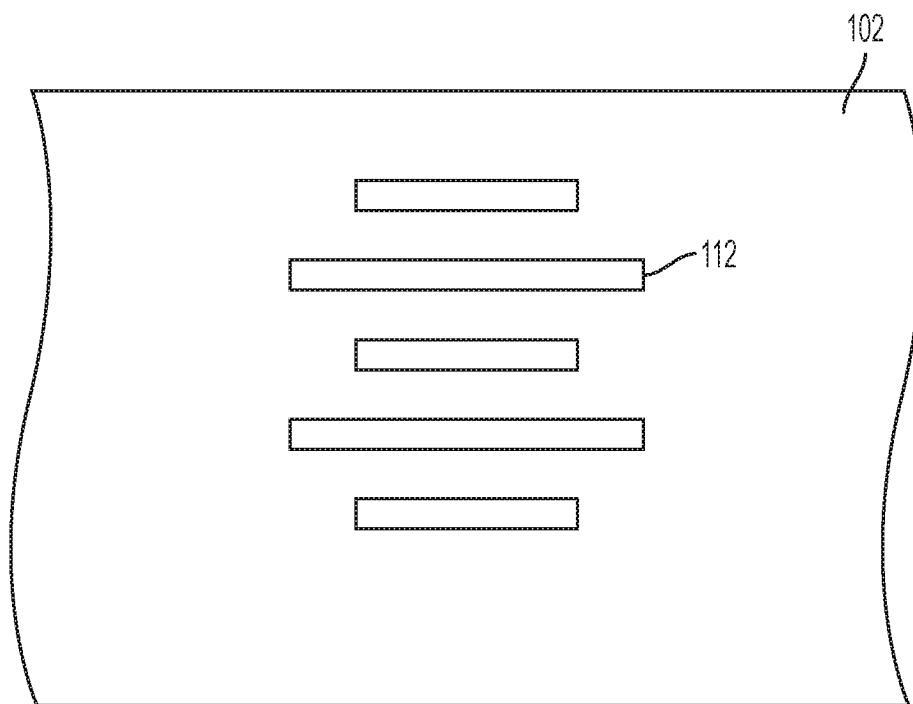

FIG. 7

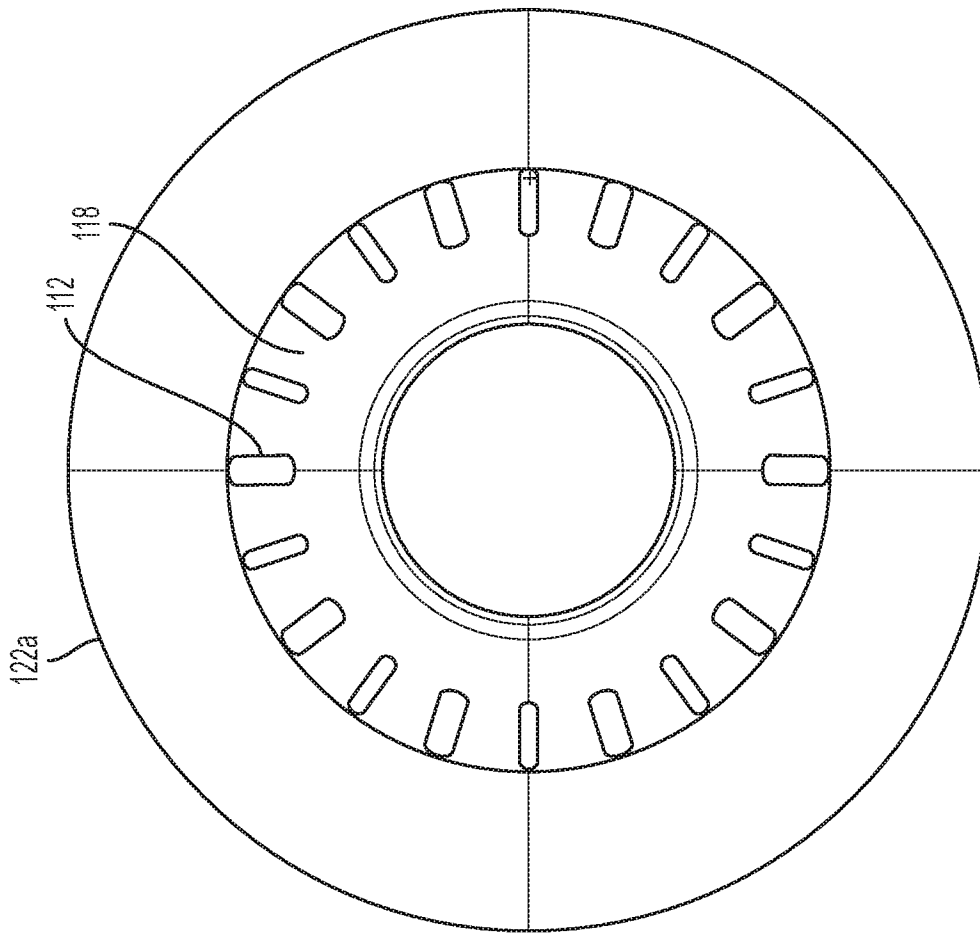

FIG. 9

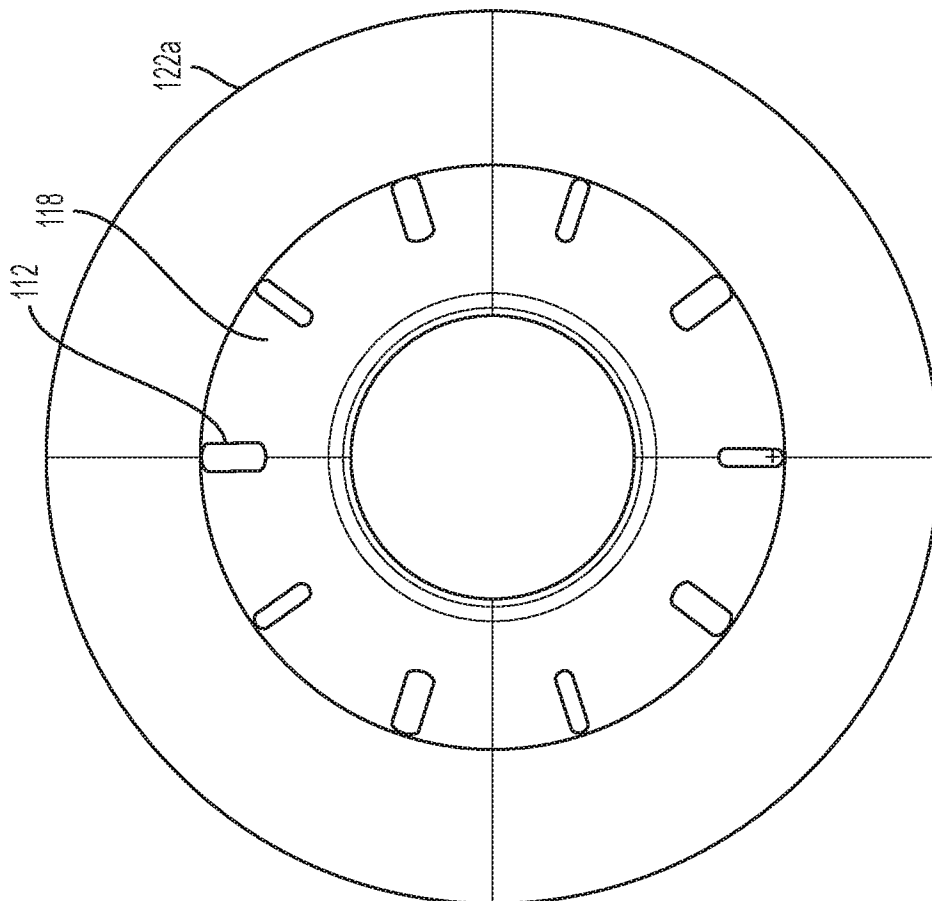

FIG. 8

INTERNATIONAL SEARCH REPORT

International application No.

PCT/US 18/20880

A. CLASSIFICATION OF SUBJECT MATTER
 IPC(8) - F01D 25/04, F04D 29/66, F04D 29/40, F01D 25/24, F03B 11/02 (2018.01)
 CPC - F01D 25/04, F04D 29/66, F01D 25/06, F04D 29/40, F05D 2240/14, F01D 5/143, F01D 25/24

According to International Patent Classification (IPC) or to both national classification and IPC

B. FIELDS SEARCHED

Minimum documentation searched (classification system followed by classification symbols)

See Search History Document

Documentation searched other than minimum documentation to the extent that such documents are included in the fields searched

See Search History Document

Electronic data base consulted during the international search (name of data base and, where practicable, search terms used)

See Search History Document

C. DOCUMENTS CONSIDERED TO BE RELEVANT

Category*	Citation of document, with indication, where appropriate, of the relevant passages	Relevant to claim No.
X -- A	US 2002/0004002 A1 (IRIE et al.) 10 January 2002 (10.01.2002) Entire document, especially para [0064], [0073], [0090]-[0091], [0093]-[0094] and figs. 1, 7 and 15.	1-3, 6-8, 12-13, 17-22 ----- 4-5, 10, 14-16
X -- A	US 2014/0020975 A1 (KONIG) 23 January 2014 (23.01.2014) Entire document, especially para [0067]-[0073], [0084], [0088], [0093]-[0096] and figs. 2 and 4.	1-3, 6-9, 11-13, 17-22 ----- 4-5
A	US 2015/0211545 A1 (PRATT & WHITNEY CANADA CORP.) 30 July 2015 (30.07.2015) Entire document.	1-22
A	US 2008/0199306 A1 (LEBRET) 21 August 2008 (21.08.2008) Entire document.	1-22
A	US 2009/0246007 A1 (JOHANN) 01 October 2009 (01.10.2009) Entire document.	1-22
A	US 2005/0111968 A1 (LAPWORTH) 26 May 2005 (26.05.2005) Entire document.	1-22
A	US 2003/0138317 A1 (BARNETT et al.) 24 July 2003 (24.07.2003) Entire document.	1-22

Further documents are listed in the continuation of Box C.

See patent family annex.

* Special categories of cited documents:	"T" later document published after the international filing date or priority date and not in conflict with the application but cited to understand the principle or theory underlying the invention
"A" document defining the general state of the art which is not considered to be of particular relevance	"X" document of particular relevance; the claimed invention cannot be considered novel or cannot be considered to involve an inventive step when the document is taken alone
"E" earlier application or patent but published on or after the international filing date	"Y" document of particular relevance; the claimed invention cannot be considered to involve an inventive step when the document is combined with one or more other such documents, such combination being obvious to a person skilled in the art
"L" document which may throw doubts on priority claim(s) or which is cited to establish the publication date of another citation or other special reason (as specified)	"&" document member of the same patent family
"O" document referring to an oral disclosure, use, exhibition or other means	
"P" document published prior to the international filing date but later than the priority date claimed	

Date of the actual completion of the international search
24 April 2010

Date of mailing of the international search report

29 MAY 2018

Name and mailing address of the ISA/US
 Mail Stop PCT, Attn: ISA/US, Commissioner for Patents
 P.O. Box 1450, Alexandria, Virginia 22313-1450
 Facsimile No. 571-273-8300

Authorized officer:
Lee W. Young

PCT Helpdesk: 571-272-4300
 PCT OSP: 571-272-7774