

G. P. FENNER.  
PRINTING PRESS.

APPLICATION FILED JULY 17, 1909.

Patented Feb. 7, 1911.

3 SHEETS—SHEET 1.

983,698.

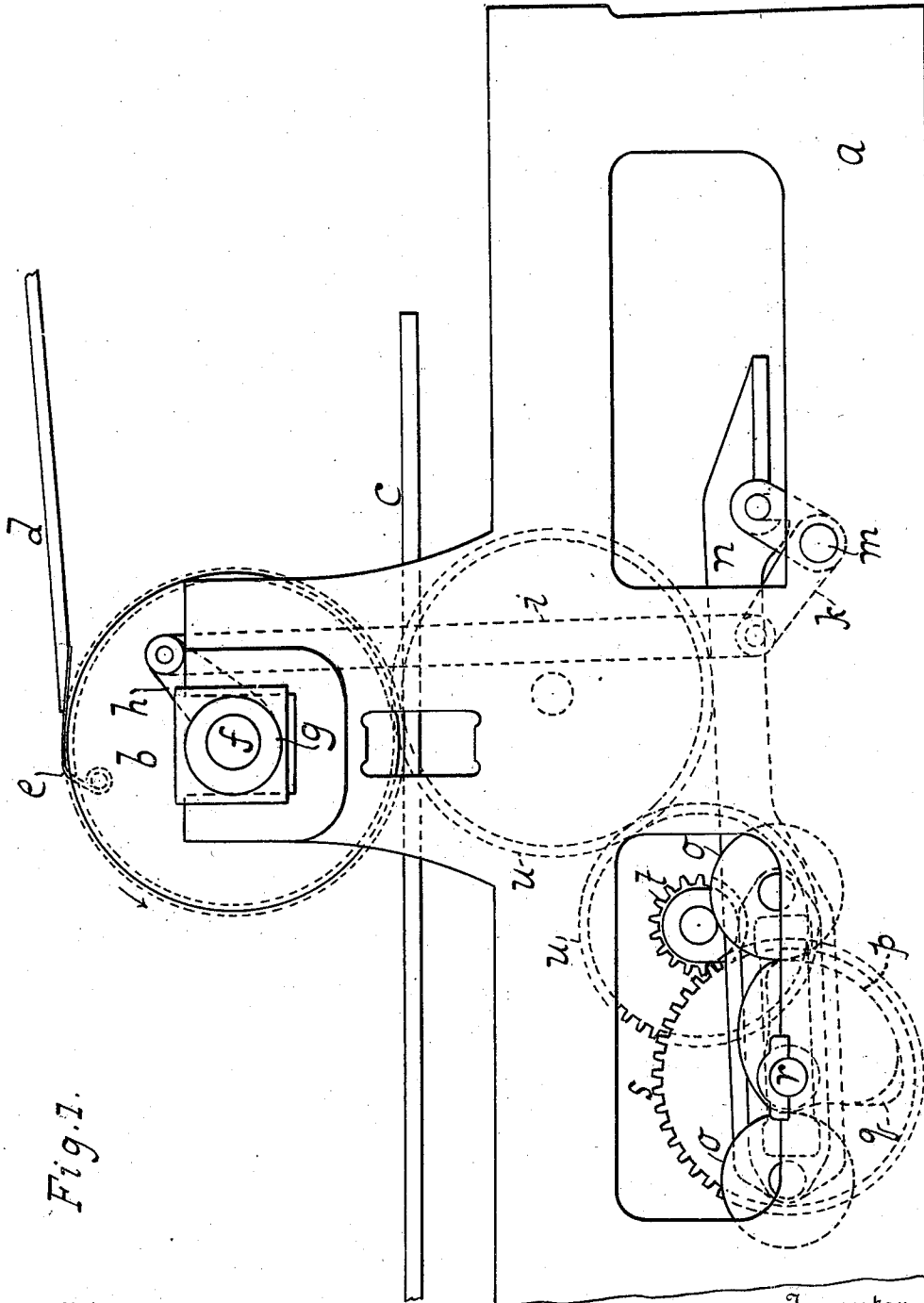

Fig. 1.

Witnesses:  
*William Miller*  
*Christian Almetraedt*

Inventor  
*George P. Fenner*  
By his Attorneys  
*Haufler & Harland*

G. P. FENNER.  
PRINTING PRESS.

APPLICATION FILED JULY 17, 1909.

983,698.

Patented Feb. 7, 1911.

3 SHEETS—SHEET 2.

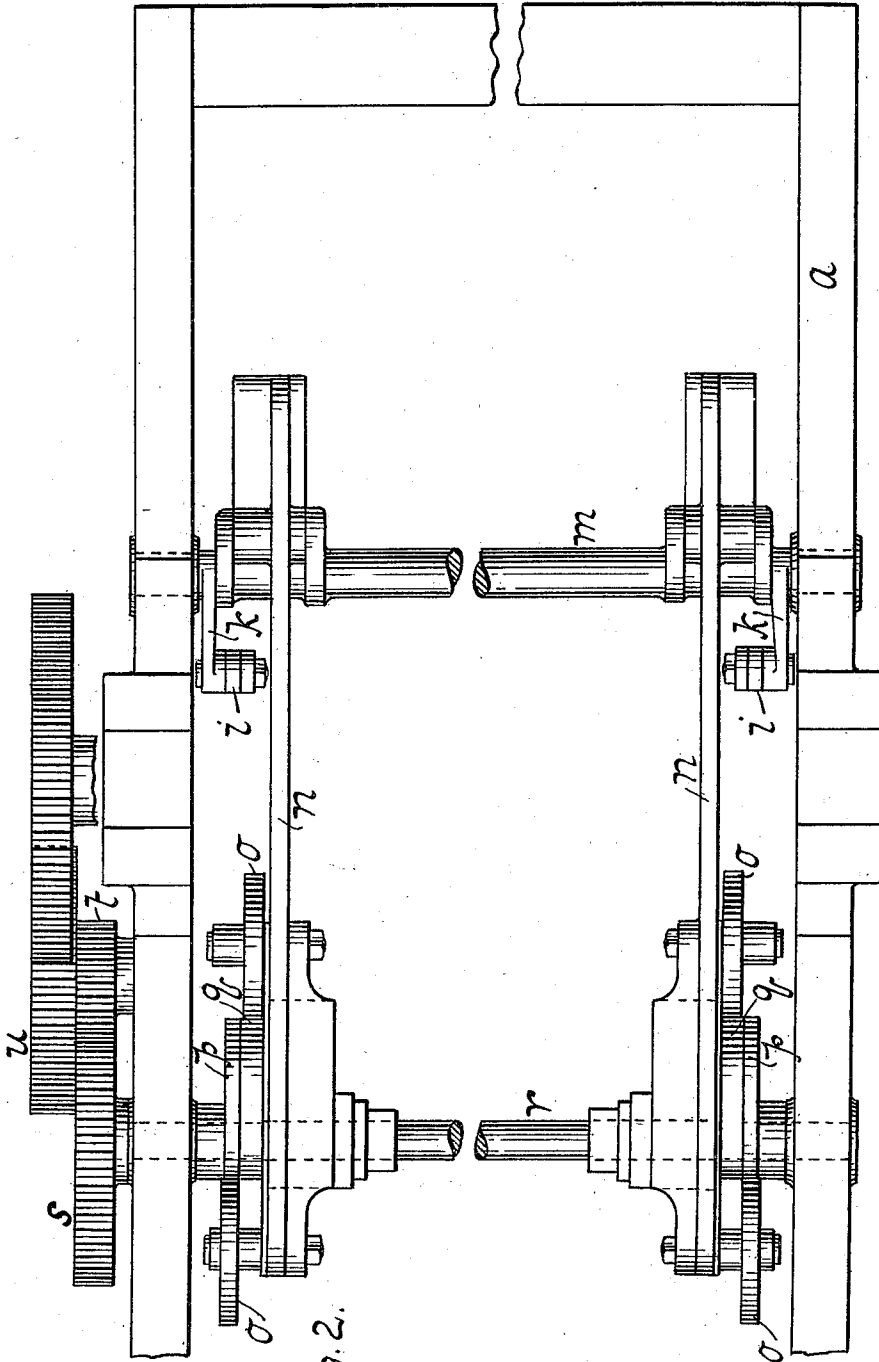

Fig. 2.

Witnesses:  
William Miller  
Christian Almstaedt

Inventor  
George P. Fenner  
By his Attorneys  
Hauff & Wankland

G. P. FENNER.  
 PRINTING PRESS.

APPLICATION FILED JULY 17, 1909.

Patented Feb. 7, 1911.

3 SHEETS-SHEET 3.

983,698.

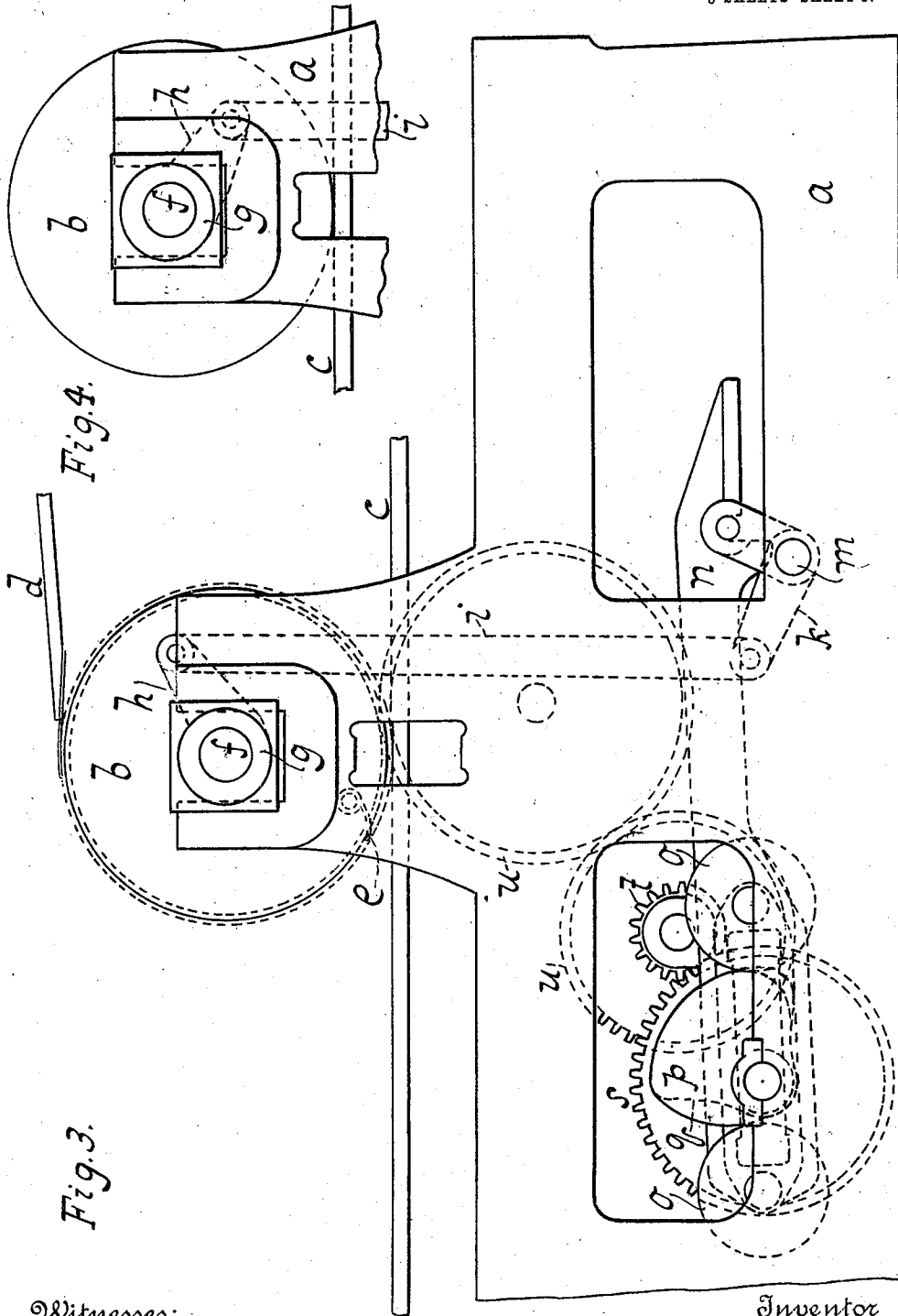

Fig. 4.

Fig. 3.

Witnesses:  
*William Miller*  
*Christian Almstaedt*

Inventor  
**George P. Fenner**  
 By his Attorneys  
*Hauff & Weland*

# UNITED STATES PATENT OFFICE.

GEORGE P. FENNER, OF NEW LONDON, CONNECTICUT.

PRINTING-PRESS.

983,698.

Specification of Letters Patent.

Patented Feb. 7, 1911.

Application filed July 17, 1909. Serial No. 508,157.

To all whom it may concern:

Be it known that I, GEORGE P. FENNER, a citizen of the United States, residing at New London, county of New London, and State of Connecticut, have invented new and useful Improvements in Printing-Presses, of which the following is a specification.

This invention relates to a printing press and the object of the invention is to accomplish the raising of the impression cylinder steadily from the time it starts until it is fully lifted. The time consumed in lifting is such that the tail of the sheet which has been printed has passed out from under the feed guide before the cylinder is clear up. This object is accomplished by the arrangement of mechanism set forth in the following specification and claim and illustrated in the annexed drawing in which—

Figure 1 is a side elevation of a printing press embodying my invention. Fig. 2 is a plan view of Fig. 1, the impression cylinder and type bed having been removed. Fig. 3 is a side elevation showing parts in different position than in Fig. 1. Fig. 4 is a like view showing parts in different position than in Fig. 3.

In this drawing the letter *a* indicates the base or supporting frame.

The impression cylinder is indicated at *b* and the type bed at *c*. The sheets coming off the feed board *d* are taken by the grippers *e* and carried about by the cylinder to the type bed.

The shaft of the cylinder *b* is shown at *f* and is mounted in an eccentric sleeve *g* from which extends arm *h* connected with rod *i*. This rod *i* is actuated by lever *k* fulcrumed at *m* and engaged by a reciprocating connection *n* provided with two antifricition disks *o*. Between these disks *o* are mounted cams *p*, *q* on shaft *r*, the gears *s* of which mesh by gears *t* and *u* with gears on the impression cylinder so as to receive motion therefrom. As the cams *p*, *q* are rotated the

connection *n* is reciprocated to oscillate the lever *k* and causes the lifting rod and connection *i* to swing the arm with eccentric sleeve *g* to raise or lower the cylinder *b*.

As seen a double cam face is provided by the two cams *p* and *q* acting respectively on the roller *o* provided for each face.

The arrangement before set forth gives an easy upward and downward movement continuous from the start to the finish.

The drawing shows a complete cam lifting mechanism for each side of the press that is, two such mechanisms but only one is necessary. Shaft *m* is oscillated by the cams on the opposite sides of the press from the gears. This makes it unnecessary to have the same cam mechanism with connections *n* on the side of the press next to the gears. All such and similar modifications are included in the scope of this invention.

I claim:

In a press, the combination of a reciprocatory type bed, an impression cylinder, eccentric sleeves supporting said cylinder and having operating arms connected thereto, gearing for operating the impression cylinder, a countershaft operatively connected to said gearing and equipped with two pairs of cams arranged toward the opposite sides of the press, and a pair of reciprocatory members connected to the operating arms of the respective sleeves of the impression cylinder; each member having a pair of laterally offset rollers cooperative with the respective cams of each pair whereby steady rising and falling motion is imparted to both sides of the impression cylinder.

In testimony whereof I have hereunto set my hand in the presence of two subscribing witnesses.

GEORGE P. FENNER.

Witnesses:

E. L. HUDSON,  
W. D. WELLS.