



(51) International Patent Classification:
H04W 52/38 (2009.01)

(21) International Application Number:
PCT/IB2018/055612

(22) International Filing Date:
26 July 2018 (26.07.2018)

(25) Filing Language: English

(26) Publication Language: English

(30) Priority Data:
62/538,236 28 July 2017 (28.07.2017) US

(71) Applicant: TELEFONAKTIEBOLAGET LM ERICSSON (PUBL) [SE/SE]; 164 83 Stockholm (SE).

(72) Inventors: LIBERG, Olof; Wollmar Yxkullsgatan 50A, SE-118 50 Stockholm (SE). SUI, Yutao; Ankdammsgatan 25 lgh 1703, SE-171 67 Solna (SE). TIRRONEN, Tuomas; Savitaipaleentie 9 B, FI-00950 Helsinki (FI). HÖGLUND, Andreas; Igelbacken 39, SE-170 62 Solna (SE).

(74) Agent: RAHMER, David et al.; Ericsson Canada Inc., 8275 Route Transcanadienne, Saint-Laurent, Québec H4S 0B6 (CA).

(81) Designated States (unless otherwise indicated, for every kind of national protection available): AE, AG, AL, AM, AO, AT, AU, AZ, BA, BB, BG, BH, BN, BR, BW, BY, BZ, CA, CH, CL, CN, CO, CR, CU, CZ, DE, DJ, DK, DM, DO, DZ, EC, EE, EG, ES, FI, GB, GD, GE, GH, GM, GT, HN, HR, HU, ID, IL, IN, IR, IS, JO, JP, KE, KG, KH, KN, KP, KR, KW, KZ, LA, LC, LK, LR, LS, LU, LY, MA, MD, ME, MG, MK, MN, MW, MX, MY, MZ, NA, NG, NI, NO, NZ,

OM, PA, PE, PG, PH, PL, PT, QA, RO, RS, RU, RW, SA, SC, SD, SE, SG, SK, SL, SM, ST, SV, SY, TH, TJ, TM, TN, TR, TT, TZ, UA, UG, US, UZ, VC, VN, ZA, ZM, ZW.

(84) Designated States (unless otherwise indicated, for every kind of regional protection available): ARIPO (BW, GH, GM, KE, LR, LS, MW, MZ, NA, RW, SD, SL, ST, SZ, TZ, UG, ZM, ZW), Eurasian (AM, AZ, BY, KG, KZ, RU, TJ, TM), European (AL, AT, BE, BG, CH, CY, CZ, DE, DK, EE, ES, FI, FR, GB, GR, HR, HU, IE, IS, IT, LT, LU, LV, MC, MK, MT, NL, NO, PL, PT, RO, RS, SE, SI, SK, SM, TR), OAPI (BF, BJ, CF, CG, CI, CM, GA, GN, GQ, GW, KM, ML, MR, NE, SN, TD, TG).

Declarations under Rule 4.17:
— as to the applicant's entitlement to claim the priority of the earlier application (Rule 4.17(iii))

Published:
— with international search report (Art. 21(3))



(54) Title: COUPLING LOSS REPORTING IN WIRELESS COMMUNICATION NETWORKS

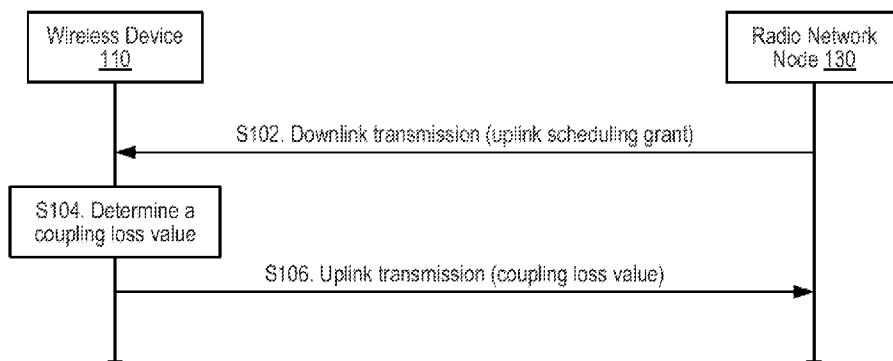

Fig. 5

(57) Abstract: Methods and related wireless devices and radio network nodes are described in which the wireless devices can report coupling loss values to radio network nodes in wireless communication networks. The coupling loss value is determined based at least in part on an estimated coupling loss at the wireless device and a coverage extension power threshold associated with a determined coverage extension mode of the wireless device.

COUPLING LOSS REPORTING IN WIRELESS COMMUNICATION NETWORKS**RELATED APPLICATIONS**

[0001] The present application claims the benefits of priority of U.S. Provisional Patent Application No. 62/538,236, entitled “COUPLING LOSS REPORTING IN WIRELESS COMMUNICATION NETWORKS”, and filed at the United States Patent and Trademark Office on July 28, 2017, the content of which is incorporated herein by reference.

TECHNICAL FIELD

[0002] The present description generally relates to wireless communications and wireless communication networks, and more particularly relates to coupling loss reporting in wireless communication networks.

BACKGROUND

[0003] In Release 13, 3GPP developed NB-IoT. This new radio access technology is dedicated to providing connectivity to services and applications demanding qualities such as reliable indoor coverage and high capacity in combination with low device complexity and optimized power consumption.

[0004] In this description, Coupling Loss (CL) is the expression used to describe the loss in signal strength between the transmitting node and the receiving node. The 3GPP specifications referred to are using the term Path Loss (PL) to describe this loss in signal strength.

[0005] *NPRACH Transmission and Power Control*

[0006] NB-IoT uses repeated transmissions to extend its coverage compared to earlier supported 3GPP radio access technologies. When accessing the system, a User Equipment (UE), or more generally, a wireless device (WD) may for example repeat the Narrow Band Random Access Channel (NPRACH) transmission up to 128 times to achieve coverage in the most demanding situations. The NB-IoT radio interface has therefore been designed with three separate NPRACH radio resources which are each associated with a coverage range and a set of repetitions.

[0007] Figure 1 illustrates a possible NPRACH configuration. The leftmost NPRACH resource is intended for UEs in good radio conditions, where the random access preamble is sent a single time. The system may configure two additional NPRACH resources to be used by UEs in extended and extreme coverages. Each NPRACH resource is associated with a Coverage Extension (CE) level. A CE level is furthermore associated with a set of repetitions of the random access preamble. The number of repetitions is increasing with the coverage intended to be supported by the NPRACH resource.

[0008] To select a NPRACH resource, the UE measures the downlink received power and based on this and a set of broadcasted signal level thresholds makes a selection of the NPRACH resource to use for its system access, i.e. the number of times the random access preamble transmission should be repeated.

5 **[0009]** Assuming that the eNB (or more generally, a radio network node) transmits 12 NB-IoT subcarriers with 43 dBm, then the power per 15 kHz sub-carrier is ~32 dBm. If CE1 starts at a coupling loss of 144 dB and CE2 at a coupling loss of 154 dB, then the NRSRP thresholds ($P_{CE,Th.1}$ and $P_{CE,Th.2}$) may be associated with NRSRP levels of $32 - 144 = -112$ dBm and $32 - 154 = -122$ dBm as illustrated in the Figure 2.

10 **[0010]** When a UE accesses the system using the first CE level 0, i.e. CE0, it is mandated to use power control and meet a received power level target at the eNB taking its estimated path loss into account. For CE levels 1 and 2, the UE is mandated to use repetitions in combination with its maximum configurable power $P_{CMAX,c}$, which is limited by the allowed power in the cell. In 3GPP TS 36.213, release 14, V14.3.0, this procedure is specified as:

15 **[0011]** “For the lowest configured repetition level, a narrowband preamble transmission power P_{NPRACH} is determined as $P_{NPRACH} = \min\{ P_{CMAX,c}(i), \text{NARROWBAND_PREAMBLE_RECEIVED_TARGET_POWER} + P_{L_c} \}$ [dBm], where $P_{CMAX,c}(i)$ is the configured UE transmit power for narrowband IoT transmission defined in [6] for subframe i of serving cell c and P_{L_c} is the downlink path loss estimate calculated in the UE for serving cell c . For a repetition level other than the lowest configured repetition level, P_{NPRACH} is set to $P_{CMAX,c}(i)$.”

[0012] $P_{CMAX,c}$ is set within the following bounds (according to 3GPP TS 36.101, release 14, V14.4.0):

$$P_{CMAX_L,c} \leq P_{CMAX,c} \leq P_{CMAX_H,c}$$

25 **[0013]** where

$$P_{CMAX_L,c} = \text{MIN} \{ P_{EMAX,c}, P_{PowerClass} - MPR_c - A-MPR_c \}$$

$$P_{CMAX_H,c} = \text{MIN} \{ P_{EMAX,c}, P_{PowerClass} \}$$

[0014] $P_{EMAX,c}$ in the above expression is the maximum allowed power in the serving cell which is signaled to the UE using the P -max Information Element (IE) in system information block.

30 MPR_c is the maximum power reduction, and $A-MPR_c$ the additional maximum power reduction.

[0015] The *NARROWBAND_PREAMBLE_RECEIVED_TARGET_POWER* is configured by the network using the *preambleInitialReceivedTargetPower* IE. A value between -90 and -130 dBm can be configured for NB-IoT.

[0016] Assume for example that the wireless device or UE uses 23 dBm power and the *preambleInitialReceivedTargetPower* is configured to -116 dBm. Then a UE experiencing a coupling loss less than $23 - (-116) = 139$ dB will down regulate the uplink power. A UE experiencing a coupling loss above 139 dB will use its maximum configurable power to come as close to the targeted power level as possible.

[0017] Figure 3 illustrates the relation between CE level selection and NPRACH power configuration.

[0018] NPUSCH Transmission and Power Control

[0019] After the UE has successfully performed the random access procedure, it enters connected mode where the number of repetitions to use when transmitting data using the NPUSCH Format 1 and Ack/Nacks using NPUSCH Format 2 is under the control of the network. The network uses the Downlink Control Information (DCI) messages sent over the NPDCCH to control the UE repetition number. The UE output power is defined in 3GPP TS 36.213, release 14, V14.3.0, as:

[0020] “The UE transmit power $P_{\text{NPUSCH},c}(i)$ for NPUSCH transmission in NB-IoT UL slot i for the serving cell c is given by

If the number of repetitions of the allocated NPUSCH RUs is greater than 2

$$P_{\text{NPUSCH},c}(i) = P_{\text{CMAX},c}(i) \text{ [dBm]}$$

otherwise

$$P_{\text{NPUSCH},c}(i) = \min \left\{ \begin{array}{l} P_{\text{CMAX},c}(i), \\ 10 \log_{10} (M_{\text{NPUSCH},c}(i)) + P_{\text{O_NPUSCH},c}(j) + \alpha_c(j) \cdot PL_c \end{array} \right\} \text{ [dBm]}$$

where,

- $P_{\text{CMAX},c}(i)$ is the configured UE transmit power defined in [6] in NB-IoT UL slot i for serving cell c .
- $M_{\text{NPUSCH},c}(i)$ is $\{1/4\}$ for 3.75 kHz subcarrier spacing and $\{1, 3, 6, 12\}$ for 15kHz subcarrier spacing
- $P_{\text{O_NPUSCH},c}(j)$ is a parameter composed of the sum of a component $P_{\text{O_NOMINAL_NPUSCH},c}(j)$ provided from higher layers and a component $P_{\text{O_UE_NPUSCH},c}(j)$ provided by higher layers for $j=1$ and for serving cell c where

$j \in \{1, 2\}$. For NPUSCH (re)transmissions corresponding to a dynamic scheduled grant then $j=1$ and for NPUSCH (re)transmissions corresponding to the random access response grant then $j=2$. $P_{O_UE_NPUSCH,c}(2) = 0$ and $P_{O_NORMINAL_NPUSCH,c}(2) = P_{O_PRE} + \Delta_{\text{PREAMBLE_Msg3}}$, where the parameter *preambleInitialReceivedTargetPower* [8] (P_{O_PRE}) and $\Delta_{\text{PREAMBLE_Msg3}}$ are signalled from higher layers for serving cell c .

- For $j=1$, for NPUSCH format 2, $\alpha_c(j)=1$; for NPUSCH format 1, $\alpha_c(j)$ is provided by higher layers for serving cell c . For $j=2$, $\alpha_c(j) = 1$.
- PL_c is the downlink path loss estimate calculated in the UE for serving cell c in dB and $PL_c = nrs\text{-Power} + nrs\text{-PowerOffsetNonAnchor} - \text{higher layer filtered NRSRP}$, where *nrs-Power* is provided by higher layers and Subclause 16.2.2, and *nrs-powerOffsetNonAnchor* is set to zero if it is not provided by higher layers and NRSRP is defined in [5] for serving cell c and the higher layer filter configuration is defined in [11] for serving cell c .

$P_{\text{CMAX},c(i)}$ is the configured UE transmit power defined in [6] in NB-IoT UL slot i for serving cell c .”

[0021] Also here in connected mode the maximum configurable power $P_{\text{CMAX},c}$, is limited by lower and upper bounds as described above and is a function of $P_{\text{EMAX},c}$ which is the maximum allowed power in the serving cell and is signaled using the *P-max* IE in system information block.

[0022] In case of (re)transmissions corresponding to the random access response grant, i.e. Msg3 transmissions, the targeted NRSRP is defined by the sum of *preambleInitialReceivedTargetPower* and $\Delta_{\text{PREAMBLE_Msg3}}$. The former can, as already pointed out, be configured in the range of -90 to -130 dBm while the latter can be configured by the *deltaPreambleMsg3* IE to a value between -2 and 12 dB.

[0023] To exemplify, assume UE B in Figure 3 is assigned a single transmission using 15 kHz subcarrier for the Msg3 transmission. *preambleInitialReceivedTargetPower* is still set to -116 dBm and *deltaPreambleMsg3* is set to 0 dB. The configured power then becomes $P_{\text{NPUSCH},c} = 10 \log_{10}(1) + -116 + 1 \times 134 = 18$ dBm.

[0024] For its part, UE A would use the maximum power of 23 dBm regardless of the assignment due to being in so deep coverage which requires an assignment with multiple repetitions.

[0025] In case of subsequent NPUSCH transmission corresponding to dynamic scheduled grants then $P_{O_NOMINAL_NPUSCH,c}(j)$ can be configured in the range -126 to 24 dBm and $P_{O_UE_NPUSCH,c}(j)$ in the range -8 to +7 dB.

[0026] *Power Headroom Reporting*

5 [0027] In NB-IoT the feedback from the UE to the network is kept at a minimum level. The UE provides HARQ Ack/Nack feedback in response to NPDSCH transmissions and a power headroom report (PHR) in Msg3. The PHR feeds back the difference between the estimated needed NPUSCH uplink power and the maximum configurable UE output power which corresponds to $P_{CMAX,c}$ in NB-IoT. In section 16.2.1.1.2 of 3GPP TS 36.213 V14.3.0, the PHR
10 functionality is defined as:

[0028] “If the UE transmits NPUSCH in NB-IoT UL slot i for serving cell c , power headroom is computed using

$$PH_c(i) = P_{CMAX,c}(i) - \left\{ P_{O_NPUSCH,c}(1) + \alpha_c(1) \cdot PL_c \right\} \text{ [dB]}$$

[0029] where, $P_{CMAX,c}(i)$, $P_{O_NPUSCH,c}(1)$, $\alpha_c(1)$, and PL_c , are defined in Subclause 16.2.1.1.1.

15 [0030] The power headroom shall be rounded down to the closest value in the set [PH1, PH2, PH3, PH4] dB as defined in [10] and is delivered by the physical layer to higher layers.”

[0031] The PHR has been specified to support four code points. To support this format, the measured PHR must be mapped to one out of four reporting values. Two different mapping tables have been defined in section 9.1.23.3 of 3GPP 36.133 V14.4.0. Which of the two tables to use is
20 defined by the UE experienced SINR.

Table 1: PHR for UEs selecting CE level 0.

Reported value	Measured quantity value (dB)
POWER_HEADROOM_0	PH < 5
POWER_HEADROOM_1	5 ≤ PH < 8
POWER_HEADROOM_2	8 ≤ PH < 11
POWER_HEADROOM_3	PH ≥ 11

Table 2: PHR for UEs selecting CE level 1 or 2.

Reported value	Measured quantity value (dB)
POWER_HEADROOM_0	PH < -10
POWER_HEADROOM_1	-10 ≤ PH < -2
POWER_HEADROOM_2	-2 ≤ PH < 6
POWER_HEADROOM_3	PH ≥ 6

25 [0032] To exemplify, assume a cell where $P_{CMAX,C} = 23$ dBm, $P_{O_NOMINAL_NPUSCH,c}(j) = -116$ dBm, $P_{O_UE_NPUSCH,c}(j) = 0$ dB and $\alpha_c(1) = 1$.

[0033] UE B would calculate $PH = 23 - (-116 + 134) = 23 - 18 = 5$ dB and report PHR 1 (assuming the mapping in Table 1 is used). When receiving this PHR, the network can use it to increase the number of sub-carriers assigned to the UE from 1 to 3. The UE would as a consequence thereof increase its UL power to 23 dBm.

- 5 [0034] UE A would calculate $PH = 23 - (-116 + 164) = 23 - 18 = -25$ dB and report PHR 0 (assuming the mapping in Table 2 is used). When receiving this PHR, the network will understand that the UE is in deep coverage and needs to be assigned many repetitions.

[0035] Extending the support for the PHR report beyond transmission in Msg3 is part of the NB-IoT Release 15 work item scope.

10 SUMMARY

[0036] The Power Headroom Report (PHR) is a very valuable tool for the radio network node (e.g., eNB) to estimate the path loss (also referred to as coupling loss) to the UE sending the PHR. The example given in the previous section shows that for UE A the value of the PHR is to inform the eNB that the UE is in deep coverage. This is however redundant information – the radio network node already possesses this information from the UE's choice to access the network on the NPRACH associated with CE level 2.

- 15 [0037] The PHR is measured relative to a coupling loss threshold that is meaningful in the context of the NB-IoT open loop power control that is used in the normal coverage range, i.e. for NPRACH CE level 0 and for NPUSCH using no or one repetition. The information the PHR conveys can be used in the assignment of the number of subcarriers and of the modulation and coding scheme (MCS). For the extended coverage domain (i.e., for CE level 1 and level 2), the PHR becomes less meaningful partly due to the UEs being far from the open loop power control coupling loss threshold, and due to the limited granularity of the PHR.

- 25 [0038] Hence, for UEs in extended coverage, it is proposed to replace the PHR reporting with a modified or enhanced PHR reporting, referred to in the present description as a Coupling Loss Report (CLR) (or as Coupling Loss Reporting) for UEs in extended coverage. One advantage of replacing the PHR with a CLR for UEs in extended coverage is that the CLR is reported relative to coupling loss thresholds relevant for the extended coverage range. The reported value then becomes more reliable due to a finer granularity and can be used for selecting the NPUSCH subcarrier spacing (3.75 kHz or 15 kHz) and selecting the number of repetitions with higher accuracy. This is beneficial for both UE battery life and for overall radio resource consumption.

- 30 [0039] Two scenarios may be distinguished, CLR reporting in Msg3 and CLR reporting subsequent to Msg3. The embodiments described in the description are applicable to any wireless

or cellular communication network supporting operations in extended coverage by means of configuring multiple PRACH and PUSCH coverage levels, including LTE UEs operating in CE mode A or B.

[0040] *CLR Reporting in Msg3*

5 **[0041]** When a UE selects one of CE levels 1 or 2, it is per definition measuring a coupling loss close to the threshold(s) defining the selection of the CE level. The UE should, when transmitting NPUSCH Msg3, report the difference between the estimated coupling loss and the coupling loss threshold of the selected NPRACH CE level.

10 **[0042]** As the measured coupling loss is expected to be close to the threshold of the selected CE level, a finer granularity in the reporting can be achieved compared to the current PHR for UEs in extended coverage. This added information relies on the fact that the radio network node (e.g., eNB) is already aware of which CE level the UE used for NPRACH via the number of repetitions used by the UE.

[0043] A specific CLR mapping may be associated with UEs selecting CE level 1 and 2.

15 **[0044]** *CLR Reporting Subsequent to Msg3*

[0045] When a UE is assigned repetitions for transmitting the NPUSCH, the PHR is replaced by a CLR. The UE should then report the difference between the measured coupling loss and a signaled threshold which can be offset by a factor increasing with the number of repetitions configured on the NPUSCH. In that sense, a set of thresholds could be explicitly configured for all possible repetition levels.

[0046] Alternatively, it could be possible for the UE to signal the estimated CLR difference with respect to the CLR reported in Msg3.

[0047] A specific CLR mapping could be associated with the UEs assigned repetitions on NPUSCH Format 1.

25 **[0048]** According to one aspect, some embodiments include a method performed by a wireless device (e.g., a user equipment or UE). The method generally comprises receiving an uplink scheduling grant from a radio network node (e.g., an eNB), the uplink scheduling grant being associated with an upcoming uplink transmission from the wireless device, determining a coupling loss value based at least in part on an estimated coupling loss at the wireless device and a coverage extension power threshold associated with a determined coverage extension mode of the wireless device, and transmitting the determined coupling loss value to the radio network node during the uplink transmission.

[0049] In some embodiments, the coupling loss value is determined based at least in part on a difference between the estimated coupling loss and the coverage extension power threshold associated with the determined coverage extension mode of the wireless device.

[0050] In some embodiments, the method may comprise, or further comprise, determining the coverage extension mode of the wireless device as a function of a measured power of a signal received from the radio network node and a plurality of coverage extension power thresholds, each coverage extension power threshold being associated with a coverage extension mode. In such embodiments, the measured power of a signal received from the radio network node may be a NB-IoT Received Signal Received Power (NRSRP) measurement.

[0051] In some embodiments, the method may comprise, or further comprise, receiving the plurality of coverage extension power thresholds from the radio network node. In such embodiments, the plurality of coverage extension power thresholds may be received from the radio network node as part of System Information Broadcast (SIB) signaling or as part of Radio Resource Control (RRC) signaling.

[0052] In some embodiments, the uplink scheduling grant may be received as part of a Random Access Response (RAR) message of a random access procedure. In such embodiments, the determined coupling loss value may be transmitted as part of a Msg3 message of the random access procedure.

[0053] In some embodiments, the received uplink scheduling grant may comprise a number of repetitions associated with the upcoming uplink transmission, and the determined coverage extension mode of the wireless device may be determined based at least in part on the number of repetitions comprised in the uplink scheduling grant.

[0054] In some embodiments, the uplink scheduling grant may be received as part of a Downlink Control Information (DCI) message, which, in some embodiments, may be received from the radio network node over the NB-IoT Physical Downlink Control Channel (NPDCCH). In such embodiments, the determined coupling loss value may be transmitted as part of an uplink message which, in some embodiments, may be transmitted over the NB-IoT Physical Uplink Shared Channel (NPUSCH).

[0055] According to another aspect, some embodiments include a wireless device (e.g., a UE, a NB-IoT UE, etc.) adapted, configured, or operable, to perform one or more wireless device functionalities (e.g., actions, operations, steps, etc.) as described herein.

[0056] In some embodiments, the wireless device may comprise one or more communication interfaces configured to communicate with one or more other wireless devices and/or with one or

more radio network nodes, and processing circuitry operatively connected to the communication interface, the processing circuitry being configured to perform one or more wireless device functionalities as described herein. In some embodiments, the processing circuitry may comprise at least one processor and at least one memory storing instructions which, upon being executed
5 by the processor, configure the at least one processor to perform one or more wireless device functionalities as described herein.

[0057] In some embodiments, the wireless device may comprise one or more modules configured to perform one or more wireless device functionalities as described herein.

[0058] According to another aspect, some embodiments include a computer program product
10 comprising a non-transitory computer-readable storage medium storing computer-readable program instructions or code which, upon being executed by processing circuitry (e.g., at least one processor) of the wireless device configure the processing circuitry to perform one or more wireless device functionalities as described herein.

[0059] According to another aspect, some embodiments include a method performed by a radio
15 network node (e.g., an eNB). The method generally comprises transmitting an uplink scheduling grant to a wireless device (e.g., a UE), the uplink scheduling grant being associated with an upcoming uplink transmission from the wireless device, and receiving a coupling loss value from the wireless device during the uplink transmission, the coupling loss value being determined based at least in part on an estimated coupling loss at the wireless device and a coverage extension power
20 threshold associated with a determined coverage extension mode of the wireless device.

[0060] In some embodiments, the method may comprise, or further comprise, determining at least one uplink transmission parameter based at least in part on the received coupling loss value. In such embodiments, the at least one uplink transmission parameter may be a subcarrier spacing (e.g., 3.75 kHz or 15 kHz), a number of repetitions, or both.

[0061] In some embodiments, the method may comprise, or further comprise, transmitting the
25 plurality of coverage extension power thresholds to the wireless device. In such embodiments, the plurality of coverage extension power thresholds may be transmitted to the wireless device as part of SIB signaling or as part of RRC signaling.

[0062] In some embodiments, the uplink scheduling grant may be transmitted as part of a RAR
30 message of a random access procedure. In such embodiments, the determined coupling loss value may be received as part of a Msg3 message of the random access procedure.

[0063] In some embodiments, the transmitted uplink scheduling grant may comprise a number of repetitions associated with the upcoming uplink transmission, and the determined coverage

extension mode of the wireless device may be determined based at least in part on the number of repetitions comprised in the uplink scheduling grant.

[0064] In some embodiments, the uplink scheduling grant may be transmitted as part of a DCI message, which, in some embodiments, may be transmitted to the wireless device over the NPDCCH. In such embodiments, the determined coupling loss value may be received as part of an uplink message, which, in some embodiments, may be received over the NPUSCH.

[0065] According to another aspect, some embodiments include a radio network node adapted, configured, or operable, to perform one or more radio network node functionalities (e.g., actions, operations, steps, etc.) as described herein.

[0066] In some embodiments, the radio network node may comprise one or more communication interfaces configured to communicate with one or more wireless devices, with one or more other radio network nodes, and/or with one or more other network nodes (e.g., core network nodes), and processing circuitry operatively connected to the communication interface, the processing circuitry being configured to perform one or more radio network node functionalities as described herein. In some embodiments, the processing circuitry may comprise at least one processor and at least one memory storing instructions which, upon being executed by the processor, configure the at least one processor to perform one or more radio network node functionalities as described herein.

[0067] In some embodiments, the radio network node may comprise one or more modules configured to perform one or more radio network node functionalities as described herein.

[0068] According to another aspect, some embodiments include a computer program product comprising a non-transitory computer-readable storage medium storing computer-readable program instructions or code which, upon being executed by processing circuitry (e.g., at least one processor) of the radio network node, configure the processing circuitry to perform one or more radio network node functionalities as described herein.

[0069] This summary is not an extensive overview of all contemplated embodiments and is not intended to identify key or critical aspects or features of any or all embodiments or to delineate the scope of any or all embodiments. In that sense, other aspects and features will become apparent to those ordinarily skilled in the art upon review of the following description of specific embodiments in conjunction with the accompanying figures.

BRIEF DESCRIPTION OF THE DRAWINGS

[0070] Exemplary embodiments will be described in more detail with reference to the following figures, in which:

[0071] Figure 1 is a graph of an exemplary NPRACH configuration with three resources for coverage level 0 (CE0), 1 (CE1) and 2 (CE2).

[0072] Figure 2 is a graph of exemplary NPRACH thresholds.

[0073] Figure 3 is a graph of exemplary NPRACH CE level selection and uplink open loop power control.

[0074] Figure 4 is a schematic diagram of an example communication network in accordance with some embodiments.

[0075] Figure 5 is a signaling diagram in accordance with some embodiments.

[0076] Figure 6 is a flow chart of operations of a wireless device in accordance with some embodiments.

[0077] Figure 7 is a flow chart of operations of a radio network node in accordance with some embodiments.

[0078] Figure 8 is a block diagram of a wireless device in accordance with some embodiments.

[0079] Figure 9 is another block diagram of a wireless device in accordance with some embodiments.

[0080] Figure 10 is a block diagram of a radio network node in accordance with some embodiments.

[0081] Figure 11 is another block diagram of a radio network node in accordance with some embodiments.

DETAILED DESCRIPTION

[0082] The embodiments set forth below represent information to enable those skilled in the art to practice the embodiments. Upon reading the following description in light of the accompanying figures, those skilled in the art will understand the concepts of the description and will recognize applications of these concepts not particularly addressed herein. It should be understood that these concepts and applications fall within the scope of the description.

[0083] In the following description, numerous specific details are set forth. However, it is understood that embodiments may be practiced without these specific details. In other instances, well-known circuits, structures, and techniques have not been shown in detail in order not to obscure the understanding of the description. Those of ordinary skill in the art, with the included description, will be able to implement appropriate functionality without undue experimentation.

[0084] References in the specification to “one embodiment,” “an embodiment,” “an example embodiment,” etc., indicate that the embodiment described may include a particular feature, structure, or characteristic, but every embodiment may not necessarily include the particular

feature, structure, or characteristic. Moreover, such phrases are not necessarily referring to the same embodiment. Further, when a particular feature, structure, or characteristic is described in connection with an embodiment, it is submitted that it is within the knowledge of one skilled in the art to implement such feature, structure, or characteristic in connection with other
5 embodiments whether or not explicitly described.

[0085] As used herein, the singular forms “a,” “an,” and “the” are intended to include the plural forms as well, unless the context clearly indicates otherwise. It will be further understood that the terms “comprises,” “comprising,” “includes,” and/or “including” when used herein, specify the presence of stated features, integers, steps, operations, elements, and/or components, but do not
10 preclude the presence or addition of one or more other features, integers, steps, operations, elements, components, and/or groups thereof.

[0086] Figure 4 illustrates an example of a wireless network 100 that may be used for wireless communications. Wireless network 100 includes wireless devices (WDs) 110A-110B (collectively referred to as wireless device or wireless devices 110) and a plurality of radio
15 network nodes 130A-130B (e.g., NBs and/or RNCs in UMTS, eNBs in LTE, gNBs in NR, etc.) (collectively referred to as radio network node or radio network nodes 130) directly or indirectly connected to a core network 150 which may comprise various core network nodes (e.g., SGSNs and/or GGSNs in UMTS, MMEs, SGWs, and/or PGWs in LTE/EPC, AMFs, SMFs, and/or UPFs in NGC, etc.). The network 100 may use any suitable radio access network (RAN) deployment
20 scenarios, including UMTS Terrestrial Radio Access Network, UTRAN, Evolved UMTS Terrestrial Radio Access Network, EUTRAN, and Next Generation Radio Access Network, NG-RAN. Wireless devices 110 within coverage areas 115 may each be capable of communicating directly with radio network nodes 130 over a wireless interface. In certain embodiments, wireless devices may also be capable of communicating with each other via device-to-device (D2D)
25 communication.

[0087] As an example, wireless device 110A may communicate with radio network node 130A over a wireless interface. That is, wireless device 110A may transmit wireless signals to and/or receive wireless signals from radio network node 130A. The wireless signals may contain voice traffic, data traffic, control signals, and/or any other suitable information. In some embodiments,
30 an area of wireless signal coverage associated with a radio network node 130 may be referred to as a cell.

[0088] In accordance with broad embodiments, when the wireless device (also referred to as user equipment or UE in the present description) is in a coverage extension mode (e.g., CE1, CE2,

etc.), the wireless device determines or calculates a coupling loss value instead of a power headroom value and transmits the determined coupling loss value to the radio network node. The coupling loss value may be seen as a modified power headroom value which is modified or enhanced to take into account the coupling loss thresholds relevant for the extended coverage range of the wireless device.

[0089] One benefit of reporting a coupling loss value instead of a power headroom value for wireless devices in extended coverage is that the coupling loss value is reported relative to coupling loss threshold(s) relevant for the extended coverage range(s). The reported value then becomes more reliable due to a finer granularity and can be used for selecting more appropriate uplink transmission parameters (e.g., NPUSCH subcarrier spacing, number of repetitions, etc.) for the wireless devices.

[0090] Referring to Figure 5, a high-level signaling and operating diagram according to some embodiments is illustrated. As shown, during a downlink transmission, the radio network node 130 transmits an uplink scheduling grant to the wireless device 110 (action S102). The uplink scheduling grant is generally associated with an upcoming uplink transmission from the wireless device 110. In that sense, the uplink scheduling grant may comprise an indication of the radio resources to be used by the wireless device 110 during the upcoming uplink transmission and one or more uplink transmission parameters (e.g., transmission power, number of repetitions, etc.).

[0091] Subsequent to (though in some embodiments, prior to) receiving the uplink transmission grant, the wireless device 110 determines a coupling loss value (action S104). As will be described in more detail below, the coupling loss value may be determined in different ways. Still, in most embodiments, the coupling loss value is determined based at least in part on an estimated coupling loss (also referred to as path loss) at the wireless device 110 and on a coverage extension power threshold associated with a determined coverage extension mode of the wireless device.

[0092] Regardless of how the coupling loss value is determined, the wireless device 110 then transmits (or reports) the determined coupling loss value to the radio network node 130 during the uplink transmission, i.e. the uplink transmission associated with the previously received uplink scheduling grant (action S106).

[0093] In some embodiments, the coupling loss value may be reported by the wireless device 110 to the radio network node 130 as a coupling loss report (CLR) similar in how power headroom reports (PHR) are reported in wireless communication networks operating according to the LTE standards (see section 5.4.6 of 3GPP TS 36.321 V14.3.0 and section 16.2.1.1.2, of 3GPP TS

36.213 V14.3.0). In that sense, the coupling loss value actually reported may be a code point in a mapping table.

[0094] There are two main scenarios in which the wireless device 110 may report the coupling loss value to the radio network node 130. In a first scenario, the wireless device 110 reports the coupling loss value to the radio network node 130 during the random access procedure and more particularly as part of Msg3 of the random access procedure (after having received the random access response (RAR) comprising an uplink scheduling grant). In a second scenario, the wireless device 110 reports the coupling loss value as part of a normal uplink transmission. Embodiments according to each scenario will now be described.

10 **[0095]** *Coupling Loss Value Reporting in Msg3*

[0096] In a first embodiment of this scenario, the coupling loss value is calculated as:

$$CL = (P_{eNB} - 10\log_{10}(12) - P_{CE,Th.X}) - CL_{UE}$$

15 **[0097]** Where P_{eNB} is the configured base station power per 180 kHz and $P_{CE,Th.X}$ is the RSRP threshold of the selected CE level. Examples of RSRP thresholds and CE levels are shown in Figure 2. CL_{UE} equals the coupling loss estimated by the UE.

[0098] As an example, UE B in Figure 2 would not use the CLR as it selects CE 0. UE A would estimate a $CL = 43 - 10\log_{10}(12) - (-122) - 164 = -10$ dB.

20 **[0099]** In a second embodiment, the estimated coupling loss for a wireless device in CE2 is mapped to an integer value $k \in \{0,1, \dots, N - 1\}$ that determines the minimum positive value for the below expression:

$$\min_k \left(CL - \left(k \cdot \frac{MCL - CL_{CE,Th.2}}{N} + CL_{CE,Th.2} \right) \right)$$

[0100] Where

N is the number of code points used in the reporting of CL (i.e. in the CLR mapping).

25 $CL_{CE,Th.2} = (P_{eNB} - 10\log_{10}(12) - P_{CE,Th.2})$ defines the coupling loss associated with CE level threshold 2 (see Figure 2).

MCL is the configured maximum coupling loss for the serving cell.

[0101] In a third embodiment, the estimated CL level for a UE in CE1 is mapped to an integer value $k \in \{0,1, \dots, N - 1\}$ that determines the minimum positive value for the below expression:

$$\min_k \left(CL - \left(k \cdot \frac{CL_{CE,Th.2} - CL_{CE,Th.1}}{N} + CL_{CE,Th.1} \right) \right)$$

30 **[0102]** Where

$CL_{CE,Th.1} = (P_{eNB} - 10\log_{10}(12) - P_{CE,Th.1})$ defines the coupling loss associated with CE level threshold 1 (see Figure 2).

[0103] In a fourth embodiment, the value k indicating the estimated coupling loss is determined based on a basic threshold (e.g. $CL_{CE,Th,0}$) and the set of repetitions (e.g. $R_{CE,Th,1}$) configured for the chosen CE level $N+1$ relative the number of repetitions (e.g. $R_{CE,Th,0}$) in CE level N the as:

$$\min_k \left(CL - \left(k \cdot \frac{G \cdot \log_{10}(R_{CE,Th,1}/R_{CE,Th,0})}{N} + CL_{CE,Th,0} \right) \right)$$

5 [0104] Where

G is the expected gain in dB for each doubling of the number of repetitions (3 dB is typically a suitable number).

[0105] *Coupling Loss Value Reporting Subsequent to Msg3*

[0106] In a first embodiment of this scenario, the coupling loss value is calculated as:

$$10 \quad CL = (P_{eNB} - 10 \log_{10}(12) - P_{CE,Th,NPUSCH}) - CL_{UE}$$

[0107] Where $P_{CE,Th,NPUSCH}$ is a NRSRP threshold associated with a coupling loss value towards which the wireless device should compare its estimated coupling loss CL_{UE} when assigned one or more repetitions on the NPUSCH.

[0108] $P_{CE,Th,NPUSCH}$ could be provided to the wireless device in system information broadcast, for example in the *NPUSCH-ConfigCommon-NB* information element contained in *RadioResourceConfigCommonSIB-NB* in SIB2. Alternatively, $P_{CE,Th,NPUSCH}$ could be provided to the wireless device by means of dedicated RRC signaling. An example of how this could be done is included below:

NPUSCH-Config-NB information element

```

20  -- ASN1START
NPUSCH-ConfigCommon-NB-r13 ::= SEQUENCE {
    ack-NACK-NumRepetitions-Msg4-r13 SEQUENCE (SIZE(1.. maxNPRACH-Resources-NB-r13)) OF
    ACK-NACK-NumRepetitions-NB-r13,
25  srs-SubframeConfig-r13          ENUMERATED {
    sc0, sc1, sc2, sc3, sc4, sc5, sc6, sc7,
    sc8, sc9, sc10, sc11, sc12, sc13, sc14, sc15
    } OPTIONAL, -- Need OR
30  dmrs-Config-r13                SEQUENCE {
    threeTone-BaseSequence-r13    INTEGER (0..12)          OPTIONAL, -- Need OP
    threeTone-CyclicShift-r13     INTEGER (0..2),
    sixTone-BaseSequence-r13      INTEGER (0..14)        OPTIONAL, -- Need OP
    sixTone-CyclicShift-r13       INTEGER (0..3),
35  twelveTone-BaseSequence-r13    INTEGER (0..30)        OPTIONAL, -- Need OP
    } OPTIONAL, -- Need OR
    ul-ReferenceSignalsNPUSCH-r13  UL-ReferenceSignalsNPUSCH-NB-r13
}

40  UL-ReferenceSignalsNPUSCH-NB-r13 ::= SEQUENCE {
    groupHoppingEnabled-r13        BOOLEAN,
    groupAssignmentNPUSCH-r13      INTEGER (0..29)
    }
...
45  [[ RSRP-ThresholdsPHR-InfoList-NB-r14 ::= SEQUENCE {
    RSRPthreshold-per-repetitionLevel RSRP-Range
    } OPTIONAL, -- Need OP
]]
11

```

```

NPUSCH-ConfigDedicated-NB-r13 ::= SEQUENCE {
  ack-NACK-NumRepetitions-r13    ACK-NACK-NumRepetitions-NB-r13 OPTIONAL, -- Need ON
  npusch-AllSymbols-r13          BOOLEAN          OPTIONAL, -- Cond SRS
  groupHoppingDisabled-r13       ENUMERATED {true}    OPTIONAL  -- Need OR
}
...
[[ RSRP-ThresholdsPHR-InfoList-NB-r14 ::= SEQUENCE {
  RSRPthreshold-per-repetitionLevel RSRP-Range
} OPTIONAL, -- Need OP
]]
ACK-NACK-NumRepetitions-NB-r13 ::= ENUMERATED {r1, r2, r4, r8, r16, r32, r64, r128}

```

[0109] In a second embodiment, the coupling loss value is calculated as:

$$CL = (P_{eNB} - 10\log_{10}(12) - (P_{CE,Th,NPUSCH} + G \cdot \log_2(R_{NPUSCH}))) - CL_{UE}$$

[0110] Where R_{NPUSCH} is the number of repetitions last assigned to the NPUSCH transmission. The term $G \cdot \log_2(R_{NPUSCH})$ adjusts the coupling loss value towards which the wireless device should compare its estimated coupling loss CL_{UE} as the number of assigned NPUSCH repetitions increase. G is the gain for each doubling of repetitions and can typically be set to 3 dB. The intention of this method is to minimize CL to allow for CLR with fine granularity.

[0111] Another way of reporting CLR subsequent to Msg3 is to use the CLR a wireless device reported in Msg3 as a reference point. The wireless device can report the estimated CLR difference, i.e., how much the CLR has changed, with respect to the one reported in Msg3. This would offer finer granularity if limited number of bits are available for the reporting.

[0112] Moreover, it would also be possible to use the latest previously reported CLR as the reference point. The wireless device would then report the estimated CLR difference, i.e., how much the CLR has changed, with respect to the previously reported CLR. This would offer finer granularity if limited number of bits are available for the reporting.

[0113] *MAC layer details*

[0114] According to the current specification (3GPP TS 36.321 V14.3.0), PHR for NB-IoT is reported using Data Volume and Power Headroom Report (DPR) MAC Control Element in a MAC PDU. The size is fixed to one octet (8 bits) as follows:

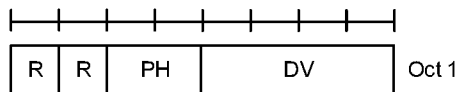

Figure 6.1.3.10-1: Data Volume and Power Headroom Report MAC control element

Table 6.1.3.10-2: Power Headroom levels for PH

PH	Power Headroom Level
0	POWER_HEADROOM_0
1	POWER_HEADROOM_1
2	POWER_HEADROOM_2
3	POWER_HEADROOM_3

[0115] The R-bits are reserved bits, set to '0' in the current protocol version. PH values are in the table above and DV values correspond to various data volume levels (not considered here).

[0116] In some embodiments, one or two of the 'R' bits may be used to indicate the wireless device is reporting a CLR in the DPR MAC Control Element (instead of a PHR). If one bit is used, the first 'R' could be reserved and set to '0', and the second bit could be set to '1' to indicate the UE is performing CLR as further described herein.

[0117] In some other embodiments, one or both of the 'R' bits would be used to gain extra granularity to the 4 power headroom levels possible with the current format, where the number of code points N described above would correspond to number of power headroom levels. For example, if one extra bit is used, the number of levels (or code points) would be $N = 2^{2+1} = 2^3 = 8$.

[0118] In some other embodiments, one of the 'R' bits is redefined to denote the used reference point. For example, if the bit is set to '0', then the initial CL calculation is the reference point, and if the bit is set to '1', the Msg3 or previous CL reporting is the reference points (as described above). This embodiment can further be combined with the embodiment above, where one 'R' bit would be used to either indicate that CLR is reported or to increase the granularity if the reported value, and the other 'R' bit would be used to indicate the reference point as described above.

[0119] In still other embodiments, a new MAC control element could be defined and reserved for CLR. For example, one octet could be reserved for the CL, where k of the 8 bits would be used to define $N = 2^k$ code points for CLR. The code points could be defined as a table, for example like the current PH values as shown above. If less than 8 bits are used for CLR, the remaining bits in the control element could be left as 'R'-bits, i.e., set to 0 in the protocol version where the control element is defined.

[0120] Figure 6 is a flow chart that illustrates operations of the wireless device 110 in accordance with some embodiments. As illustrated, the wireless device 110 receives an uplink scheduling grant from a radio network node 130, the uplink scheduling grant being associated with an upcoming uplink transmission from the wireless device 110 (action S202). The wireless device 110 further determines a coupling loss value based at least in part on an estimated coupling loss at the wireless device 110 and a coverage extension power threshold associated with a determined

coverage extension mode of the wireless device 110 (action S204). In some embodiments, the wireless device 110 may determine the coupling loss value before receiving the uplink scheduling grant while in other embodiments, the wireless device 110 may determine the coupling loss value after receiving the uplink scheduling grant. As indicated above, the wireless device 110 may determine the coupling loss value using different methods and/or different mathematical relationships. Furthermore, the way the wireless device 110 determines the coupling loss value may vary depending on whether the coupling loss value is determined during the random access procedure or during subsequent operations of the wireless device (e.g., during regular uplink data transmissions). Regardless of how the coupling loss value is determined, the wireless device 110 subsequently transmits it to the radio network node 130 during the uplink transmission, i.e., the uplink transmission associated with the previously received uplink scheduling grant (action S206).

[0121] In some embodiments, the wireless device 110 may further determine its coverage extension mode as a function of a measured power of a signal received from the radio network node 130 and a plurality of coverage extension power thresholds, each coverage extension power threshold being associated with a coverage extension mode. The power of the signal received from the radio network node 130 measured by the wireless device 110 may be the NRSRP.

[0122] In some embodiments, the wireless device 110 may further receive the plurality of coverage extension power thresholds from the radio network node 130. The wireless device 110 may, for instance, receive these coverage extension power thresholds from the radio network node 130 as part of System Information Broadcast (SIB) signaling or as part of Radio Resource Control (RRC) signaling.

[0123] In some embodiments, the wireless device 110 may receive the uplink scheduling grant as part of a RAR message of a random access procedure. In such cases, the wireless device 110 may transmit the determined coupling loss value to the radio network node 130 as part of a Msg3 message of the random access procedure.

[0124] In some embodiments, the wireless device 110 may receive the uplink scheduling grant as part of a DCI message which may be sent by the radio network node 130 to the wireless device 110 over the NPDCCH. In such cases, the wireless device 110 may transmit the determined coupling loss value to the radio network node 130 as part of an uplink message which may be sent by the wireless device 110 to the radio network node 130 over the NPUSCH.

[0125] In some embodiments, the uplink scheduling grant received by the wireless device 110 may comprise a number of repetitions associated with the upcoming uplink transmission. In such embodiments, the determined coverage extension mode of the wireless device 110 may be

determined based at least in part on the number of repetitions comprised in the uplink scheduling grant.

[0126] Figure 7 is a flow chart that illustrates operations of the radio network node 130 in accordance with some embodiments. As illustrated, the radio network node 130 transmits an uplink scheduling grant to a wireless device 110, the uplink scheduling grant being associated with an upcoming uplink transmission from the wireless device 110 (action S302). The radio network node 130 then receives a coupling loss value from the wireless device 110 during the uplink transmission, the coupling loss value being determined based at least in part on an estimated coupling loss at the wireless device 110 and a coverage extension power threshold associated with a determined coverage extension mode of the wireless device 110 (action S304).

[0127] In some embodiments, the radio network node 130 may further determine one or more uplink transmission parameters based on the coupling loss value reported by the wireless device 110. Such one or more uplink transmission parameters may include a subcarrier spacing (e.g., 3.75 kHz or 15 kHz), a number of repetitions, etc.

[0128] In some embodiments, the radio network node 130 may further transmit the plurality of coverage extension power thresholds to the wireless device 110. The radio network node may, for instance, transmit the plurality of coverage extension power thresholds to the wireless device 110 as part of SIB signaling or as part of RRC signaling.

[0129] In some embodiments, the radio network node 130 may transmit the uplink scheduling grant as part of a RAR message of a random access procedure. In such a case, the radio network node 130 may receive the determined coupling loss value from the wireless device 110 as part of a Msg3 message of the random access procedure.

[0130] In some embodiments, the radio network node 130 may transmit the uplink scheduling grant as part a DCI message, which, in some embodiments, may be transmitted to the wireless device 110 over the NPDCCH. In such a case, the radio network node 130 may receive the determined coupling loss value from the wireless device 110 as part of an uplink message, which, in some embodiments, may be received over the NPUSCH.

[0131] In some embodiments, the uplink scheduling grant transmitted by the radio network node may comprise a number of repetitions associated with the upcoming uplink transmission. In such embodiments, the determined coverage extension mode of the wireless device may be determined based at least in part on the number of repetitions comprised in the uplink scheduling grant.

[0132] Some embodiments of a wireless device 110 will now be described with respect to Figures 8 and 9. As used herein, a “wireless device” is any type of device that has access to (i.e., may be

served by) a wireless communication network by wirelessly transmitting and/or receiving signals to one or more radio network node(s). Notably, various communication standards sometimes use different terminologies when referring to or describing wireless devices. For instance, in addition to user equipment (UE), 3GPP also uses mobile terminal (MT). For its part, 3GPP2 uses the expression access terminal (AT) and IEEE 802.11 (also known as WiFi™) uses the term station (STA). Some examples of a wireless device include, but are not limited to, a User Equipment (UE) in a 3GPP network, a NB-IoT UE in a 3GPP NB-IoT network, a Machine Type Communication (MTC) device, and an Internet of Things (IoT) device.

[0133] Figure 8 is a block diagram of an exemplary wireless device 110 in accordance with some embodiments. Wireless device 110 includes one or more of a transceiver 112, processor 114, and memory 116. In some embodiments, the transceiver 112 facilitates transmitting wireless signals to and receiving wireless signals from radio network node 130 (e.g., via transmitter(s) (Tx) 118, receiver(s) (Rx) 120 and antenna(s) 122). The processor 114 executes instructions to provide some or all of the functionalities described above as being provided by wireless device 110, and the memory 116 stores the instructions to be executed by the processor 114. In some embodiments, the processor 114 and the memory 116 form processing circuitry 124.

[0134] The processor 114 may include any suitable combination of hardware to execute instructions and manipulate data to perform some or all of the described functions of wireless device 110, such as the functions of wireless device 110 described above. In some embodiments, the processor 114 may include, for example, one or more computers, one or more central processing units (CPUs), one or more microprocessors, one or more application specific integrated circuits (ASICs), one or more field programmable gate arrays (FPGAs) and/or other logic.

[0135] The memory 116 is generally operable to store instructions, such as a computer program, software, an application including one or more of logic, rules, algorithms, code, tables, etc. and/or other instructions capable of being executed by a processor such as processor 114. Examples of memory 116 include computer memory (for example, Random Access Memory (RAM) or Read Only Memory (ROM)), mass storage media (for example, a hard disk), removable storage media (for example, a Compact Disk (CD) or a Digital Video Disk (DVD)), and/or or any other volatile or non-volatile, non-transitory computer-readable and/or computer-executable memory devices that store information, data, and/or instructions that may be used by the processor 114 of wireless device 110.

[0136] Other embodiments of wireless device 110 may include additional components beyond those shown in Figure 8 that may be responsible for providing certain aspects of the wireless

device functionalities, including any of the functionalities described above and/or any additional functionalities (including any functionality necessary to support the solution(s) described above). As just one example, wireless device 110 may include input devices and circuits, output devices, and one or more synchronization units or circuits, which may be part of the processor. Input devices include mechanisms for entry of data into wireless device 110. As an example, wireless device 110 may include additional hardware 126 such as input devices and output devices. Input devices include input mechanisms such as microphone, input elements, display, etc. Output devices include mechanisms for outputting data in audio, video and/or hard copy format. For example, output devices may include a speaker, a display, etc.

5 [0137] Figure 9 is a block diagram of another exemplary wireless device 110 in accordance with some embodiments. As illustrated, in some embodiments, the wireless device 110 may comprise a series of modules (or units) 128 configured to implement some or all of the functionalities of the wireless device 110 described above. More particularly, in some embodiments, the wireless device 110 may comprise a receiving module configured to receive an uplink scheduling grant from a radio network node, the uplink scheduling grant being associated with an upcoming uplink transmission from the wireless device; a determining module configured to determine a coupling loss value based at least in part on an estimated coupling loss at the wireless device and a coverage extension power threshold associated with a determined coverage extension mode of the wireless device; and a transmitting module configured to transmit the determined coupling loss value to the radio network node during the uplink transmission.

15 [0138] It will be appreciated that the various modules 128 may be implemented as combination of hardware and/or software, for instance, the processor 114, memory 116 and transceiver(s) 112 of wireless device 110 shown in Figure 8. Some embodiments may also include additional modules to support additional and/or optional functionalities.

25 [0139] Embodiments of a radio network node 130 will now be described with respect to Figures 10 and 11.

[0140] Figure 10 is a block diagram of an exemplary radio network node 130 in accordance with some embodiments. Radio network node 130 may include one or more of a transceiver 132, processor 134, memory 136, and communication interface 146. In some embodiments, the transceiver 132 facilitates transmitting wireless signals to and receiving wireless signals from wireless devices 110 (e.g., via transmitter(s) (Tx) 138, receiver(s) (Rx) 140, and antenna(s) 142). The processor 134 executes instructions to provide some or all of the functionalities described above as being provided by a radio network node 130, the memory 136 stores the instructions to

30

be executed by the processor 134. In some embodiments, the processor 134 and the memory 136 form processing circuitry 144. The communication interface(s) 146 enable the radio network 130 to communicate with other network nodes, including other radio network nodes (via a radio access network interface) and core network nodes (via a core network interface).

5 [0141] The processor 134 may include any suitable combination of hardware to execute instructions and manipulate data to perform some or all of the described functions of radio network node 130, such as those described above. In some embodiments, the processor 134 may include, for example, one or more computers, one or more central processing units (CPUs), one or more microprocessors, one or more application specific integrated circuits (ASICs), one or more field
10 programmable gate arrays (FPGAs) and/or other logic.

[0142] The memory 136 is generally operable to store instructions, such as a computer program, software, an application including one or more of logic, rules, algorithms, code, tables, etc. and/or other instructions capable of being executed by a processor such as processor 134. Examples of
15 memory 136 include computer memory (for example, Random Access Memory (RAM) or Read Only Memory (ROM)), mass storage media (for example, a hard disk), removable storage media (for example, a Compact Disk (CD) or a Digital Video Disk (DVD)), and/or or any other volatile or non-volatile, non-transitory computer-readable and/or computer-executable memory devices that store information.

[0143] In some embodiments, the communication interface 146 is communicatively coupled to
20 the processor 134 and may refer to any suitable device operable to receive input for radio network node 130, send output from radio network node 130, perform suitable processing of the input or output or both, communicate to other devices, or any combination of the preceding. The communication interface may include appropriate hardware (e.g., port, modem, network interface card, etc.) and software, including protocol conversion and data processing capabilities, to
25 communicate through a network.

[0144] Other embodiments of radio network node 130 may include additional components beyond those shown in Figure 10 that may be responsible for providing certain aspects of the radio network node's functionalities, including any of the functionalities described above and/or any additional functionalities (including any functionality necessary to support the solutions described
30 above). The various different types of network nodes may include components having the same physical hardware but configured (e.g., via programming) to support different radio access technologies, or may represent partly or entirely different physical components.

[0145] In some embodiments, the radio network node 130 may comprise a series of modules (or units) 148 configured to implement the functionalities of the radio network node 130 described above. Referring to Figure 11, in some embodiments, the radio network node 130 may comprise a transmitting module configured to transmit an uplink scheduling grant to a wireless device, the uplink scheduling grant being associated with an upcoming uplink transmission from the wireless device; and a receiving module configured to receive a coupling loss value from the wireless device during the uplink transmission, the coupling loss value being determined based at least in part on an estimated coupling loss at the wireless device and a coverage extension power threshold associated with a determined coverage extension mode of the wireless device.

[0146] It will be appreciated that the various modules 148 may be implemented as combination of hardware and/or software, for instance, the processor 134, memory 136 and transceiver(s) 132 of radio network node 130 shown in Figure 10. Some embodiments may also include additional modules to support additional and/or optional functionalities.

[0147] Some embodiments may be represented as a non-transitory software product stored in a machine-readable medium (also referred to as a computer-readable medium, a processor-readable medium, or a computer usable medium having a computer readable program code embodied therein). The machine-readable medium may be any suitable tangible medium including a magnetic, optical, or electrical storage medium including a diskette, compact disk read only memory (CD-ROM), digital versatile disc read only memory (DVD-ROM) memory device (volatile or non-volatile), or similar storage mechanism. The machine-readable medium may contain various sets of instructions, code sequences, configuration information, or other data, which, when executed, cause a processor to perform steps in a method according to one or more of the described embodiments. Those of ordinary skill in the art will appreciate that other instructions and operations necessary to implement the described embodiments may also be stored on the machine-readable medium. Software running from the machine-readable medium may interface with circuitry to perform the described tasks.

[0148] The above-described embodiments are intended to be examples only. Alterations, modifications and variations may be effected to the particular embodiments by those of skill in the art without departing from the scope of the description.

ABBREVIATIONS

[0149] The present description may comprise one or more of the following abbreviation:

[0150] Ack Acknowledgement

[0151] AMF Access Management Function

	[0152]	CE	Coverage Enhancement
	[0153]	CL	Coupling Loss
	[0154]	CLR	Coupling Loss Reporting
	[0155]	D2D	Device-to-Device
5	[0156]	DPR	Data Volume and Power Headroom Report
	[0157]	GGSN	Gateway GPRS Support Node
	[0158]	IoT	Internet of Things
	[0159]	LTE	Long Term Evolution
	[0160]	MAC	Medium Access Control
10	[0161]	MCL	Maximum Coupling Loss
	[0162]	MME	Mobility Management Entity
	[0163]	Msg3	Message 3
	[0164]	Nack	Negative Acknowledgement
	[0165]	NB-IoT	Narrow-Band Internet of Things
15	[0166]	NGC	Next Generation Core
	[0167]	NPDCCH	NB-IoT Physical Downlink Control Channel
	[0168]	NPRACH	NB-IoT Physical Random Access Channel
	[0169]	NPUSCH	NB-IoT Physical Uplink Shared Channel
	[0170]	NR	New Radio
20	[0171]	NRSRP	NB-IoT Received Signal Received Power
	[0172]	PDU	Protocol Data Unit
	[0173]	PGW	Packet Data Network Gateway
	[0174]	PHR	Power Headroom Report
	[0175]	PL	Path Loss
25	[0176]	RNC	Radio Network Controller
	[0177]	SGSN	Serving GPRS Support Node
	[0178]	SGW	Serving Gateway
	[0179]	SINR	Signal-to-Interference and Noise Ratio
	[0180]	SMF	Session Management Function
30	[0181]	UMTS	Universal Mobile Telecommunications System
	[0182]	UPF	User Plane Function
	[0183]	UTRAN	Universal Terrestrial Radio Access Network

CLAIMS

What is claimed is:

1. A method in a wireless device, the method comprising:
 - receiving an uplink scheduling grant from a radio network node, the uplink
5 scheduling grant being associated with an upcoming uplink transmission from the wireless device;
 - determining a coupling loss value based at least in part on an estimated coupling loss at the wireless device and a coverage extension power threshold associated with a determined coverage extension mode of the wireless device;
 - 10 transmitting the determined coupling loss value to the radio network node during the uplink transmission.
2. The method of claim 1, wherein the coupling loss value is determined based at least in part on a difference between the estimated coupling loss and the coverage extension power threshold associated with the determined coverage extension mode of the wireless device.
- 15 3. The method of claim 1 or 2, further comprising determining the coverage extension mode of the wireless device as a function of a measured power of a signal received from the radio network node and a plurality of coverage extension power thresholds, each coverage extension power threshold being associated with a coverage extension mode.
4. The method of claim 3, wherein the measured power of a signal received from the radio
20 network node is a measured NB-IoT Received Signal Received Power, NRSRP.
5. The method of claim 3 or 4, further comprising receiving the plurality of coverage extension power thresholds from the radio network node.
6. The method of claim 5, wherein the plurality of coverage extension power thresholds are received from the radio network node as part of System Information Broadcast, SIB,
25 signaling or as part of Radio Resource Control, RRC, signaling.
7. The method of any one of claims 1 to 6, wherein the uplink scheduling grant is received as part of a random access response, RAR, message of a random access procedure.
8. The method of claim 7, wherein the determined coupling loss value is transmitted as part of a Msg3 message of the random access procedure.
- 30 9. The method of any one of claims 1 to 6, wherein the uplink scheduling grant is received as part of a Downlink Control Information, DCI, message.

10. The method of claim 9, wherein the DCI message is received from the radio network node over a NB-IoT Physical Downlink Control Channel, NPDCCH.
11. The method of claim 9 or 10, wherein the determined coupling loss value is transmitted as part of an uplink message.
- 5 12. The method of claim 11, wherein the uplink message is transmitted to the radio network node over a NB-IoT Physical Uplink Shared Channel, NPUSCH.
13. The method of any one of claims 1, 2, and 9 to 12, wherein the received uplink scheduling grant comprises a number of repetitions associated with the upcoming uplink transmission, and wherein the determined coverage extension mode of the wireless device is determined
10 based at least in part on the number of repetitions comprised in the uplink scheduling grant.
14. A wireless device adapted to:
 - receive an uplink scheduling grant from a radio network node, the uplink scheduling grant being associated with an upcoming uplink transmission from the wireless
15 device;
 - determine a coupling loss value based at least in part on an estimated coupling loss at the wireless device and a coverage extension power threshold associated with a determined coverage extension mode of the wireless device;
 - transmit the determined coupling loss value to the radio network node during the
20 uplink transmission.
15. The wireless device of claim 14, wherein the coupling loss value is determined based at least in part on a difference between the estimated coupling loss and the coverage extension power threshold associated with the determined coverage extension mode of the wireless device.
- 25 16. The wireless device of claim 14 or 15, further adapted to determine the coverage extension mode of the wireless device as a function of a measured power of a signal received from the radio network node and a plurality of coverage extension power thresholds, each coverage extension power threshold being associated with a coverage extension mode.
17. The wireless device of claim 16, wherein the measured power of a signal received from the
30 radio network node is a measured NB-IoT Received Signal Received Power, NRSRP.
18. The wireless device of claim 16 or 17, further adapted to receive the plurality of coverage extension power thresholds from the radio network node.

19. The wireless device of claim 18, wherein the plurality of coverage extension power thresholds are received from the radio network node as part of System Information Broadcast, SIB, signaling or as part of Radio Resource Control, RRC, signaling.
20. The wireless device of any one of claims 14 to 19, wherein the uplink scheduling grant is received as part of a random access response, RAR, message of a random access procedure.
21. The wireless device of claim 20, wherein the determined coupling loss value is transmitted as part of a Msg3 message of the random access procedure.
22. The wireless device of any one of claims 14 to 19, wherein the uplink scheduling grant is received as part of a Downlink Control Information, DCI, message.
23. The wireless device of claim 22, wherein the DCI message is received from the radio network node over a NB-IoT Physical Downlink Control Channel, NPDCCH.
24. The wireless device of claim 22 or 23, wherein the determined coupling loss value is transmitted as part of an uplink message.
25. The wireless device of claim 24, wherein the uplink message is transmitted to the radio network node over a NB-IoT Physical Uplink Shared Channel, NPUSCH.
26. The wireless device of any one of claims 14, 15, and 22 to 25, wherein the received uplink scheduling grant comprises a number of repetitions associated with the upcoming uplink transmission, and wherein the determined coverage extension mode of the wireless device is determined based at least in part on the number of repetitions comprised in the uplink scheduling grant.
27. A computer program product comprising a non-transitory computer readable storage medium having computer readable program code embodied in the medium, the computer readable program code comprising:
 - computer readable program code to receive an uplink scheduling grant from a radio network node, the uplink scheduling grant being associated with an upcoming uplink transmission from a wireless device;
 - computer readable program code to determine a coupling loss value based at least in part on an estimated coupling loss at the wireless device and a coverage extension power threshold associated with a determined coverage extension mode of the wireless device;

computer readable program code to transmit the determined coupling loss value to the radio network node during the uplink transmission.

28. The computer program product of claim 27, wherein the computer readable program code further comprises computer readable program code to operate according to the method of any of claims 2 to 13.
29. A method in a radio network node, the method comprising:
- transmitting an uplink scheduling grant to a wireless device, the uplink scheduling grant being associated with an upcoming uplink transmission from the wireless device;
 - receiving a coupling loss value from the wireless device during the uplink transmission, the coupling loss value being determined based at least in part on an estimated coupling loss at the wireless device and a coverage extension power threshold associated with a determined coverage extension mode of the wireless device.
30. The method of claim 29, further comprising determining at least one uplink transmission parameter based at least in part on the received coupling loss value.
31. The method of claim 30, wherein the at least one uplink transmission parameter is at least one of a subcarrier spacing and a number of repetitions.
32. The method of any one of claims 29 to 31, further comprising transmitting a plurality of coverage extension power thresholds to the wireless device.
33. The method of claim 32, wherein the plurality of coverage extension power thresholds are transmitted to the wireless device as part of System Information Broadcast, SIB, signaling or as part of Radio Resource Control, RRC, signaling.
34. The method of any one of claims 29 to 33, wherein the uplink scheduling grant is transmitted as part of a random access response, RAR, message of a random access procedure.
35. The method of claim 34, wherein the determined coupling loss value is received as part of a Msg3 message of the random access procedure.
36. The method of any one of claims 29 to 33, wherein the uplink scheduling grant is transmitted as part of a Downlink Control Information, DCI, message.
37. The method of claim 36, wherein the DCI message is transmitted to the wireless device over a NB-IoT Physical Downlink Control Channel, NPDCCH.

38. The method of claim 36 or 37, wherein the determined coupling loss value is received as part of an uplink message.
39. The method of claim 38, wherein the uplink message is received from the wireless device over a NB-IoT Physical Uplink Shared Channel, NPUSCH.
- 5 40. The method of any one of claims 29 to 31 and 36 to 39, wherein the transmitted uplink scheduling grant comprises a number of repetitions associated with the upcoming uplink transmission, and wherein the determined coverage extension mode of the wireless device is determined based at least in part on the number of repetitions comprised in the uplink scheduling grant.
- 10 41. A radio network node adapted to:
- transmit an uplink scheduling grant to a wireless device, the uplink scheduling grant being associated with an upcoming uplink transmission from the wireless device;
- receive a coupling loss value from the wireless device during the uplink transmission, the coupling loss value being determined based at least in part on an
- 15 estimated coupling loss at the wireless device and a coverage extension power threshold associated with a determined coverage extension mode of the wireless device.
42. The radio network node of claim 41, further adapted to determine at least one uplink transmission parameter based at least in part on the received coupling loss value.
43. The radio network node of claim 42, wherein the at least one uplink transmission
- 20 parameter is at least one of a subcarrier spacing and a number of repetitions.
44. The radio network node of any one of claims 41 to 43, further adapted to transmit a plurality of coverage extension power thresholds to the wireless device.
45. The radio network node of claim 44, wherein the plurality of coverage extension power thresholds are transmitted to the wireless device as part of System Information Broadcast, SIB, signaling or as part of Radio Resource Control, RRC, signaling.
- 25 46. The radio network node of any one of claims 41 to 45, wherein the uplink scheduling grant is transmitted as part of a random access response, RAR, message of a random access procedure.
47. The radio network node of claim 46, wherein the determined coupling loss value is
- 30 received as part of a Msg3 message of the random access procedure.
48. The radio network node of any one of claims 41 to 45, wherein the uplink scheduling grant is transmitted as part of a Downlink Control Information, DCI, message.

49. The radio network node of claim 48, wherein the DCI message is transmitted to the wireless device over a NB-IoT Physical Downlink Control Channel, NPDCCH.
50. The radio network node of claim 48 or 49, wherein the determined coupling loss value is received as part of an uplink message.
- 5 51. The radio network node of claim 50, wherein the uplink message is received from the wireless device over a NB-IoT Physical Uplink Shared Channel, NPUSCH.
52. The radio network node of any one of claims 41 to 43 and 48 to 51, wherein the transmitted uplink scheduling grant comprises a number of repetitions associated with the upcoming uplink transmission, and wherein the determined coverage extension mode of
10 the wireless device is determined based at least in part on the number of repetitions comprised in the uplink scheduling grant.
53. A computer program product comprising a non-transitory computer readable storage medium having computer readable program code embodied in the medium, the computer readable program code comprising:
- 15 computer readable program code to transmit an uplink scheduling grant to a wireless device, the uplink scheduling grant being associated with an upcoming uplink transmission from the wireless device;
- computer readable program code to receive a coupling loss value from the wireless device during the uplink transmission, the coupling loss value being determined based at
20 least in part on an estimated coupling loss at the wireless device and a coverage extension power threshold associated with a determined coverage extension mode of the wireless device.
54. The computer program product of claim 53, wherein the computer readable program code further comprises computer readable program code to operate according to the method of
25 any of claims 30 to 40.

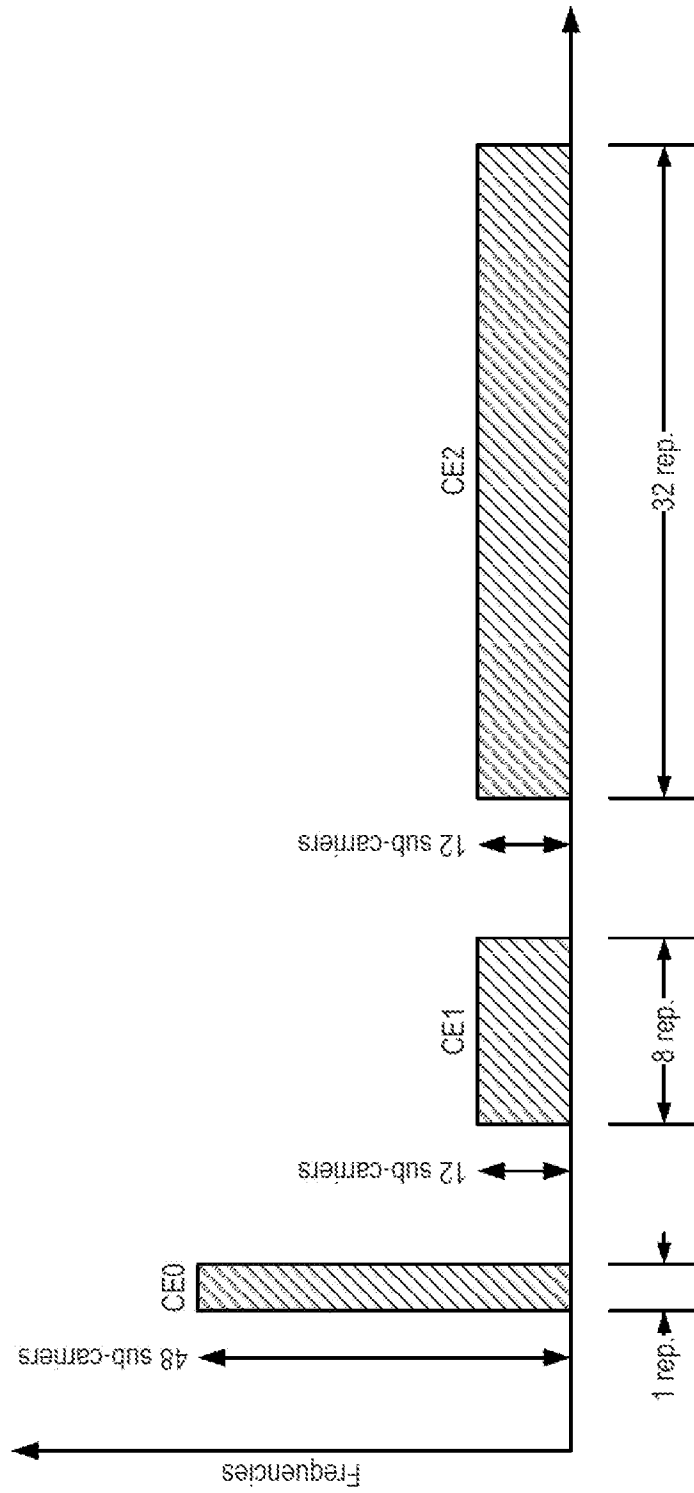

Fig. 1

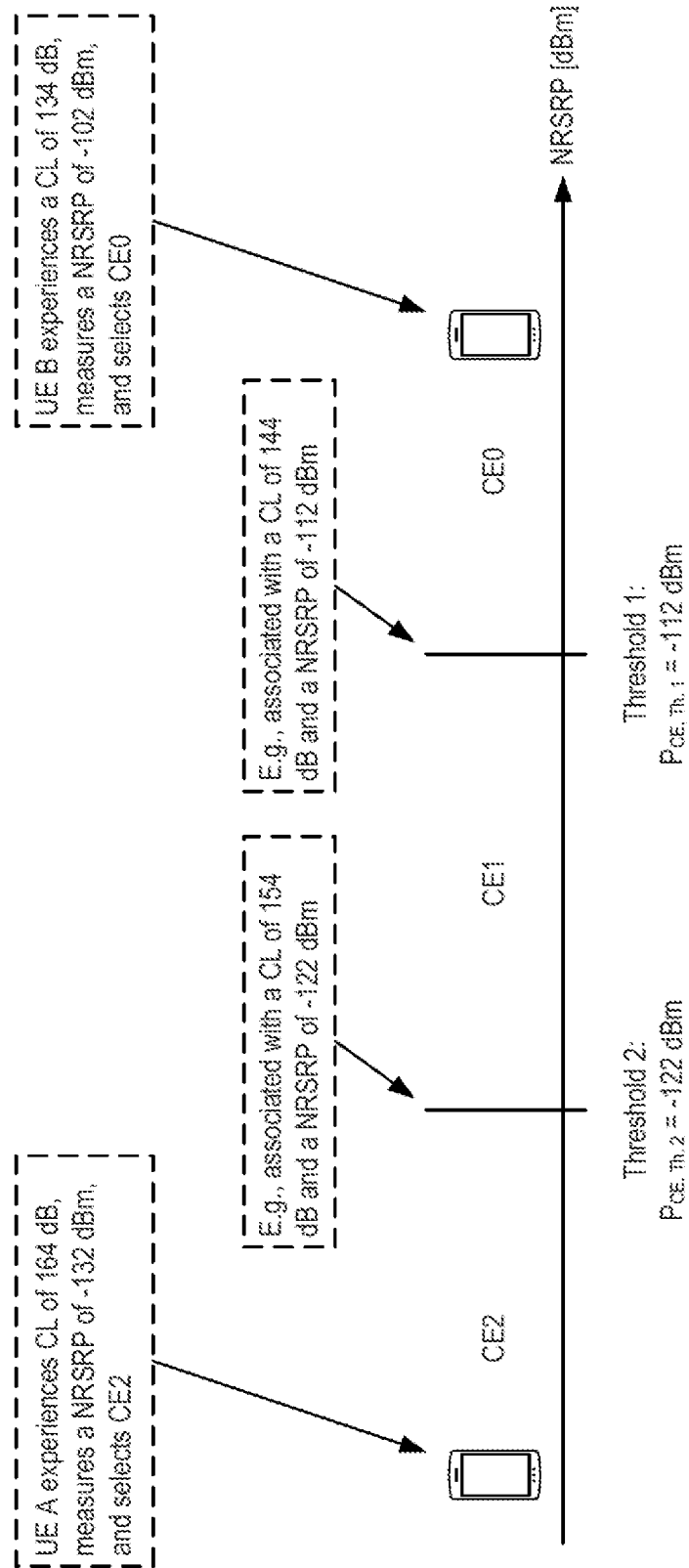

Fig. 2

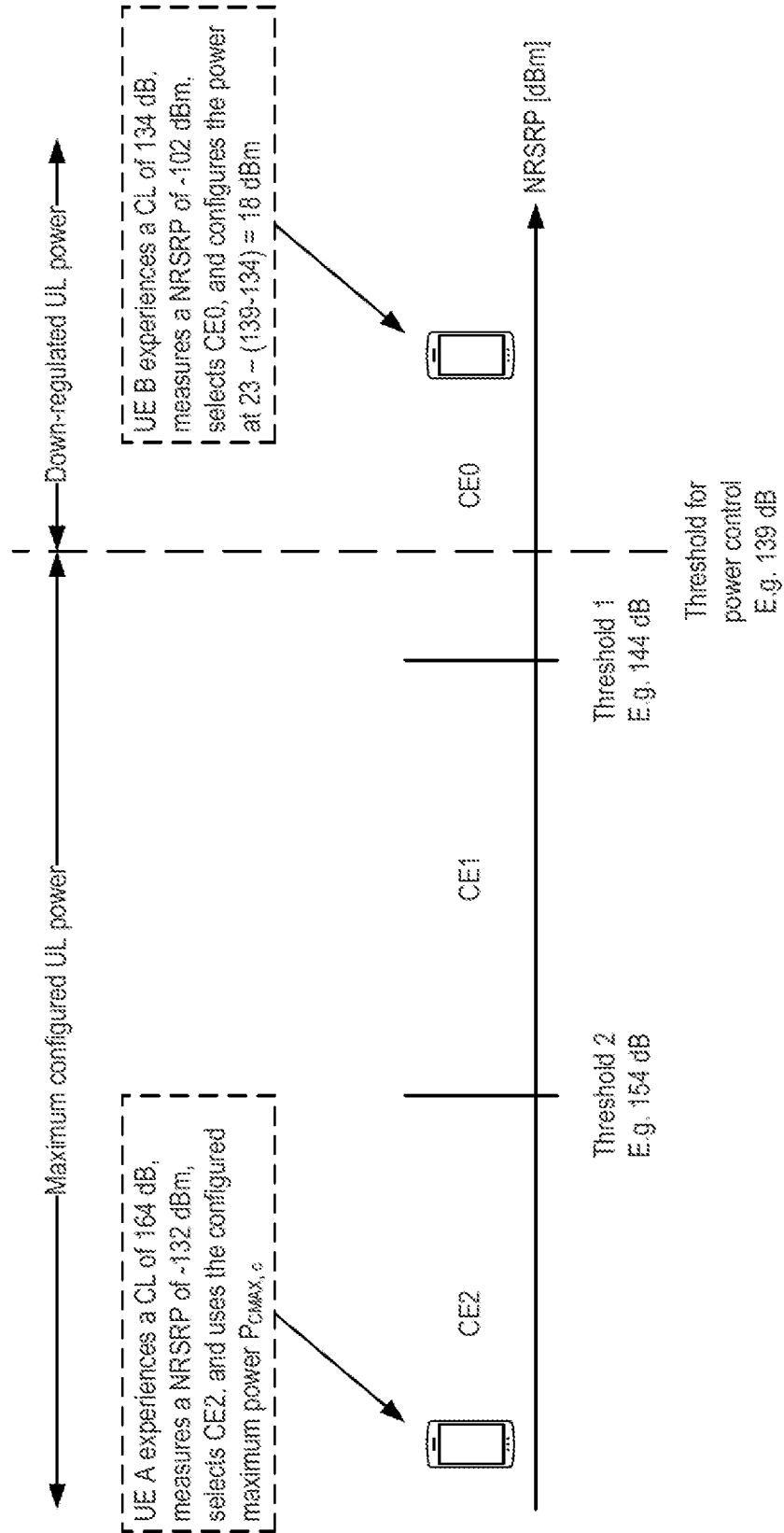

Fig. 3

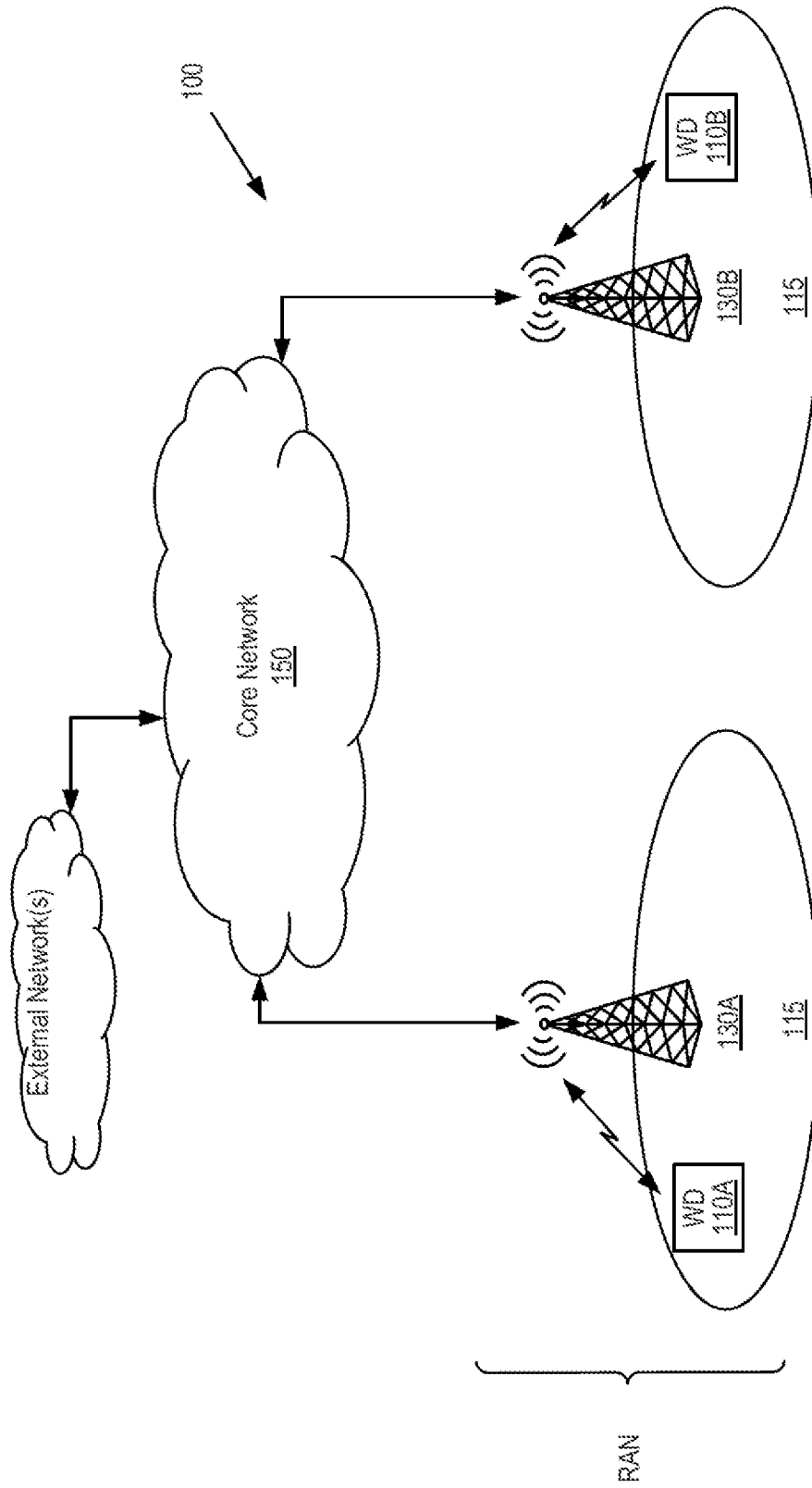

Fig. 4

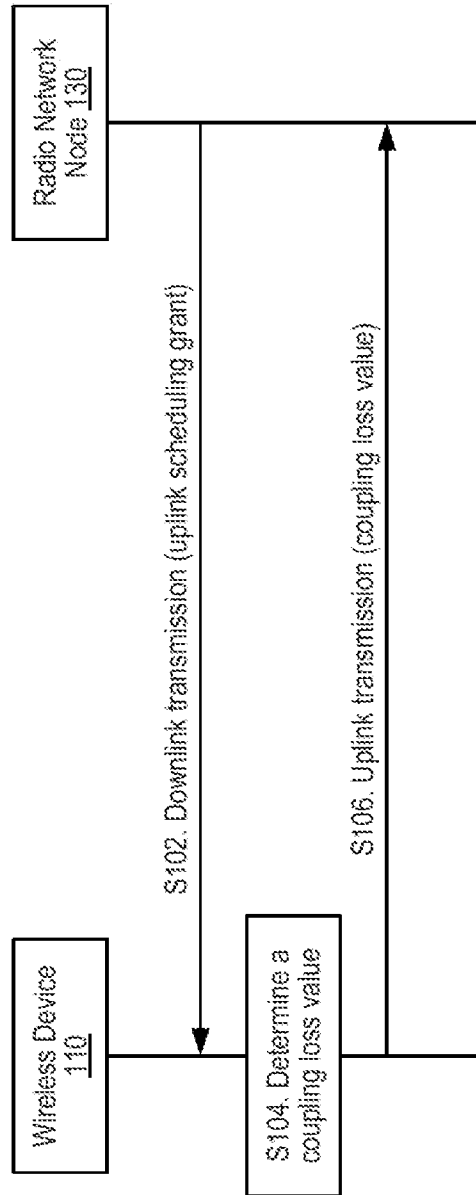

Fig. 5

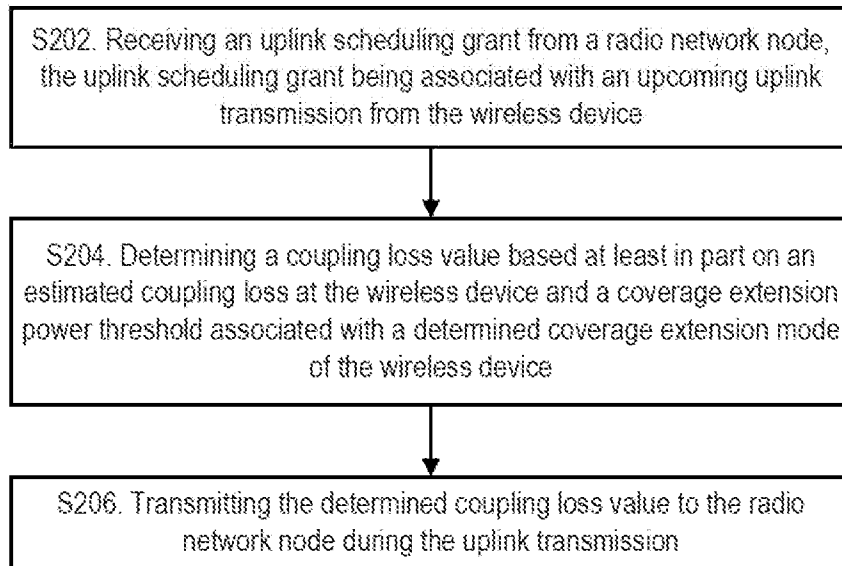

Fig. 6

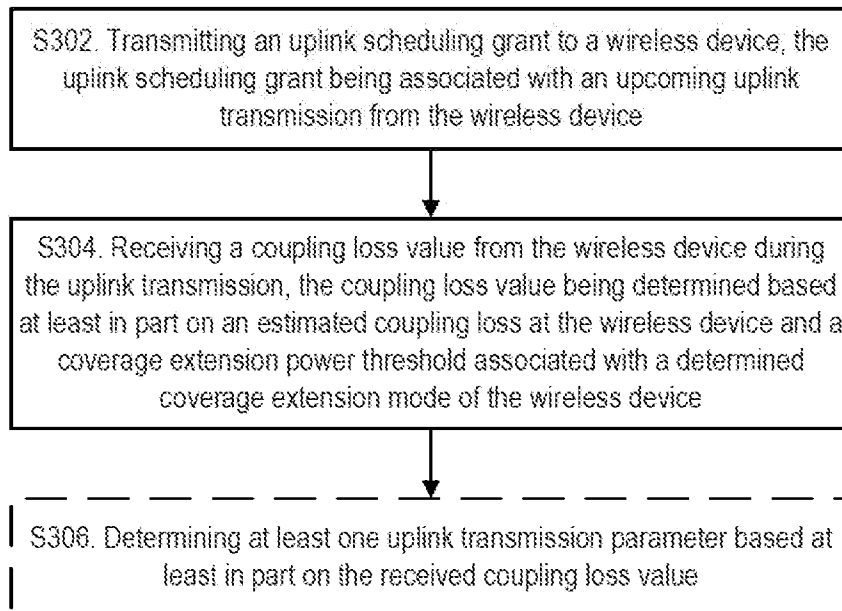

Fig. 7

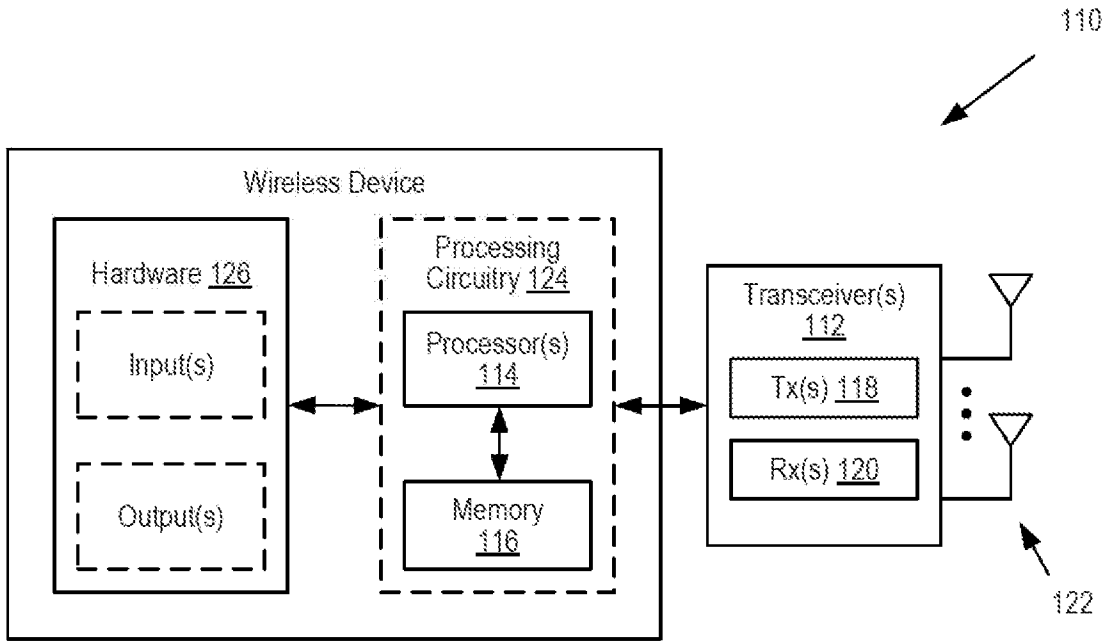

Fig. 8

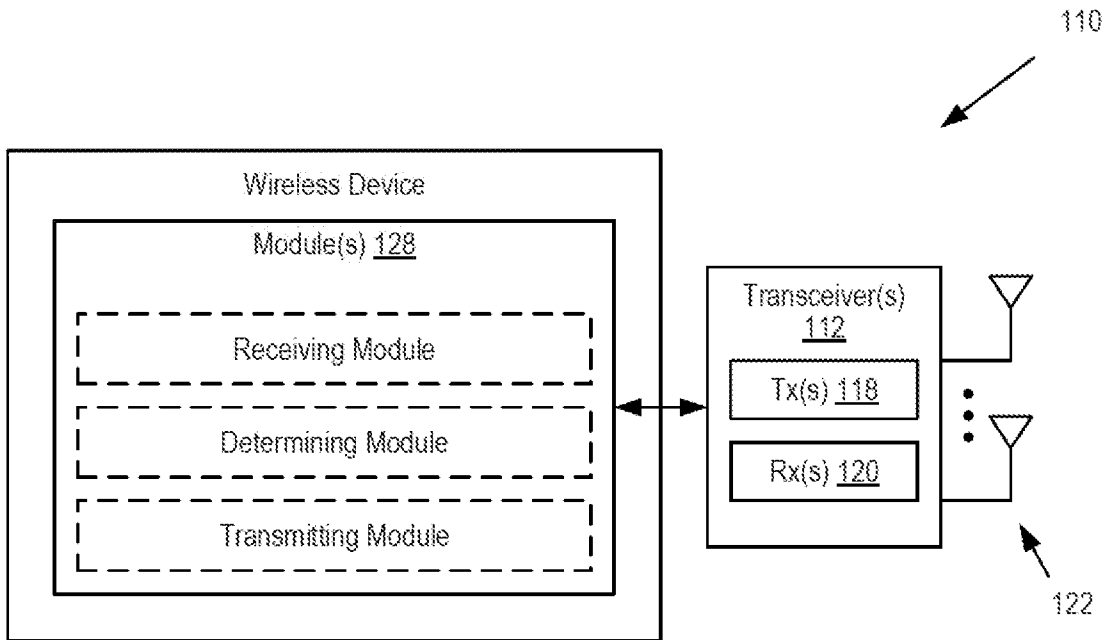

Fig. 9

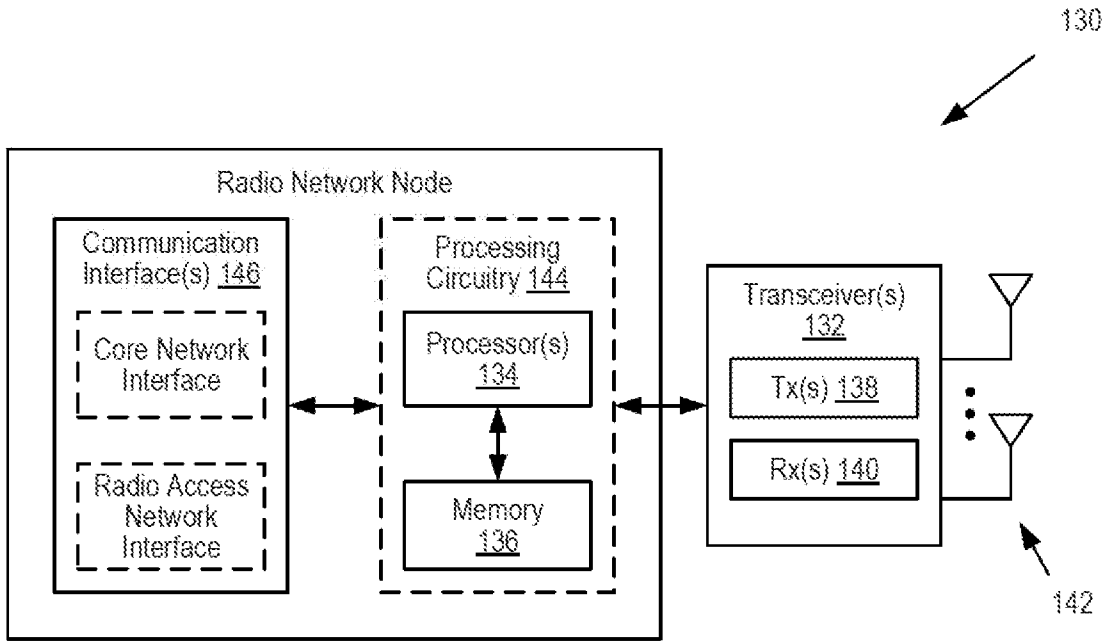

Fig. 10

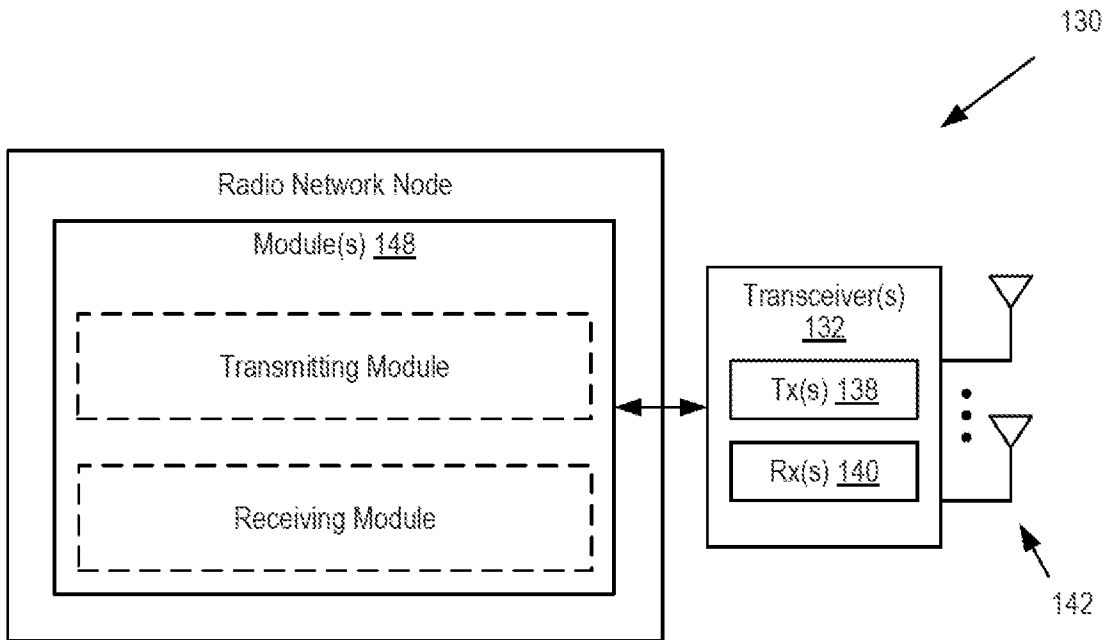

Fig. 11

INTERNATIONAL SEARCH REPORT

International application No
PCT/IB2018/055612

A. CLASSIFICATION OF SUBJECT MATTER
INV. H04W52/38
ADD.
According to International Patent Classification (IPC) or to both national classification and IPC

B. FIELDS SEARCHED
Minimum documentation searched (classification system followed by classification symbols)
H04W

Documentation searched other than minimum documentation to the extent that such documents are included in the fields searched

Electronic data base consulted during the international search (name of data base and, where practicable, search terms used)
EPO-Internal, WPI Data

C. DOCUMENTS CONSIDERED TO BE RELEVANT

Category*	Citation of document, with indication, where appropriate, of the relevant passages	Relevant to claim No.
X	EP 3 094 146 A1 (HUAWEI TECH CO LTD [CN]) 16 November 2016 (2016-11-16) paragraph [0089] - paragraph [0093]; figures 3A, 3B	1-54
A	----- US 2016/353440 A1 (LEE MOON-IL [US] ET AL) 1 December 2016 (2016-12-01) paragraph [0312] - paragraph [0337] ----- -/--	1-54

Further documents are listed in the continuation of Box C.

See patent family annex.

* Special categories of cited documents :

- "A" document defining the general state of the art which is not considered to be of particular relevance
- "E" earlier application or patent but published on or after the international filing date
- "L" document which may throw doubts on priority claim(s) or which is cited to establish the publication date of another citation or other special reason (as specified)
- "O" document referring to an oral disclosure, use, exhibition or other means
- "P" document published prior to the international filing date but later than the priority date claimed

- "T" later document published after the international filing date or priority date and not in conflict with the application but cited to understand the principle or theory underlying the invention
- "X" document of particular relevance; the claimed invention cannot be considered novel or cannot be considered to involve an inventive step when the document is taken alone
- "Y" document of particular relevance; the claimed invention cannot be considered to involve an inventive step when the document is combined with one or more other such documents, such combination being obvious to a person skilled in the art
- "&" document member of the same patent family

Date of the actual completion of the international search
1 October 2018

Date of mailing of the international search report
10/10/2018

Name and mailing address of the ISA/
European Patent Office, P.B. 5818 Patentlaan 2
NL - 2280 HV Rijswijk
Tel. (+31-70) 340-2040,
Fax: (+31-70) 340-3016

Authorized officer
Riposati, Benedetto

C(Continuation). DOCUMENTS CONSIDERED TO BE RELEVANT		
Category*	Citation of document, with indication, where appropriate, of the relevant passages	Relevant to claim No.
A	<p>ERICSSON: "On the UL power control of NPRACH in NB-IoT", 3GPP DRAFT; RP-171218 - ON THE UL POWER CONTROL OF NPRACH IN NB-IOT, 3RD GENERATION PARTNERSHIP PROJECT (3GPP), MOBILE COMPETENCE CENTRE ; 650, ROUTE DES LUCIOLES ; F-06921 SOPHIA-ANTIPOLIS CEDEX ; FR</p> <p>, vol. TSG RAN, no. West Palm Beach, US; 20170605 - 20170609 5 June 2017 (2017-06-05), XP051280705, Retrieved from the Internet: URL:http://www.3gpp.org/ftp/Meetings_3GPP_SYNC/RAN/Docs/ [retrieved on 2017-06-05] section 2.1 section 2.5 section 3</p> <p style="text-align: center;">-----</p>	1-54
A	<p>"3 Generation Partnership Project; Technical Specification Group Radio Access Network; Evolved Universal Terrestrial Radio Access (E-UTRA); Physical layer procedures (Release 14)", 3GPP STANDARD ; TECHNICAL SPECIFICATION ; 3GPP TS 36.213, 3RD GENERATION PARTNERSHIP PROJECT (3GPP), MOBILE COMPETENCE CENTRE ; 650, ROUTE DES LUCIOLES ; F-06921 SOPHIA-ANTIPOLIS CEDEX ; FRANCE, vol. RAN WG1, no. V14.3.0, 23 June 2017 (2017-06-23), pages 50-305, XP051299004, [retrieved on 2017-06-23] section 6.2</p> <p style="text-align: center;">-----</p>	1-54
A	<p>"3rd Generation Partnership Project; Technical Specification Group Radio Access Network; Evolved Universal Terrestrial Radio Access (E-UTRA); Medium Access Control (MAC) protocol specification (Release 14)", 3GPP STANDARD ; TECHNICAL SPECIFICATION ; 3GPP TS 36.321, 3RD GENERATION PARTNERSHIP PROJECT (3GPP), MOBILE COMPETENCE CENTRE ; 650, ROUTE DES LUCIOLES ; F-06921 SOPHIA-ANTIPOLIS CEDEX ; FRANCE, vol. RAN WG2, no. V14.3.0, 23 June 2017 (2017-06-23), pages 1-107, XP051299019, [retrieved on 2017-06-23] section 5.1.1 section 6.1.5</p> <p style="text-align: center;">-----</p> <p style="text-align: center;">-/--</p>	1-54

INTERNATIONAL SEARCH REPORT

International application No

PCT/IB2018/055612

C(Continuation). DOCUMENTS CONSIDERED TO BE RELEVANT		
Category*	Citation of document, with indication, where appropriate, of the relevant passages	Relevant to claim No.
A	<p>"3rd Generation Partnership Project; Technical Specification Group Radio Access Network; Evolved Universal Terrestrial Radio Access (E-UTRA); Radio Resource Control (RRC); Protocol specification (Release 14)", 3GPP STANDARD ; TECHNICAL SPECIFICATION ; 3GPP TS 36.331, 3RD GENERATION PARTNERSHIP PROJECT (3GPP), MOBILE COMPETENCE CENTRE ; 650, ROUTE DES LUCIOLES ; F-06921 SOPHIA-ANTIPOLIS CEDEX ; FRANCE, vol. RAN WG2, no. V14.3.0, 13 July 2017 (2017-07-13), pages 1-745, XP051336663, [retrieved on 2017-07-13] page 401 -----</p>	1-54

INTERNATIONAL SEARCH REPORT

Information on patent family members

International application No PCT/IB2018/055612

Patent document cited in search report	Publication date	Patent family member(s)	Publication date	
EP 3094146	A1	16-11-2016	CN 105519219 A	20-04-2016
			EP 3094146 A1	16-11-2016
			EP 3383123 A1	03-10-2018
			ES 2672477 T3	14-06-2018
			JP 6374518 B2	15-08-2018
			JP 2017505064 A	09-02-2017
			KR 20160114663 A	05-10-2016
			KR 20180041249 A	23-04-2018
			KR 20180097785 A	31-08-2018
			US 2016338070 A1	17-11-2016
			US 2018084557 A1	22-03-2018
			WO 2015113228 A1	06-08-2015

US 2016353440	A1	01-12-2016	AU 2015211013 A1	18-08-2016
			CN 106233794 A	14-12-2016
			EP 3100536 A1	07-12-2016
			JP 2017513260 A	25-05-2017
			KR 20160114688 A	05-10-2016
			US 2016353440 A1	01-12-2016
			WO 2015116732 A1	06-08-2015
