

(12) STANDARD PATENT
(19) AUSTRALIAN PATENT OFFICE

(11) Application No. **AU 2005294731 B2**

- (54) Title
Airbag cushion with cinch tube for reduced out-of-position effects
- (51) International Patent Classification(s)
B60R 21/16 (2006.01) **B60R 21/26** (2006.01)
- (21) Application No: **2005294731** (22) Date of Filing: **2005.08.01**
- (87) WIPO No: **WO06/041552**
- (30) Priority Data
- (31) Number (32) Date (33) Country
10/959,256 **2004.10.06** **US**
- (43) Publication Date: **2006.04.20**
- (44) Accepted Journal Date: **2012.04.19**
- (71) Applicant(s)
Autoliv ASP, Inc.
- (72) Inventor(s)
Smith, Bradley W.;Jamison, Patrick D.;Williams, Jeffrey D.;Rose, Larry D.;Jordan, Michael P.
- (74) Agent / Attorney
Griffith Hack, GPO Box 1285, Melbourne, VIC, 3001
- (56) Related Art
US6139048A
JP05-85295A

(19) World Intellectual Property Organization
International Bureau



(43) International Publication Date
20 April 2006 (20.04.2006)

PCT

(10) International Publication Number
WO 2006/041552 A2

(51) International Patent Classification:
B60R 21/16 (2006.01) *B60R 21/26* (2006.01)

(74) Agent: LAURENCE, Kevin B.; One Utah Center, 201 So. Main Street, Suite 1100, Salt Lake City, Utah 84111 (US).

(21) International Application Number:
PCT/US2005/027255

(81) Designated States (unless otherwise indicated, for every kind of national protection available): AE, AG, AL, AM, AT, AU, AZ, BA, BB, BG, BR, BW, BY, BZ, CA, CH, CN, CO, CR, CU, CZ, DE, DK, DM, DZ, EC, EE, EG, ES, FI, GB, GD, GE, GH, GM, HR, HU, ID, IL, IN, IS, JP, KE, KG, KM, KP, KR, KZ, LC, LK, LR, LS, LT, LU, LV, MA, MD, MG, MK, MN, MW, MX, MZ, NA, NG, NI, NO, NZ, OM, PG, PH, PL, PT, RO, RU, SC, SD, SE, SG, SK, SL, SM, SY, TJ, TM, TN, TR, TT, TZ, UA, UG, US, UZ, VC, VN, YU, ZA, ZM, ZW.

(22) International Filing Date: 1 August 2005 (01.08.2005)

(25) Filing Language: English

(26) Publication Language: English

(30) Priority Data:
10/959,256 6 October 2004 (06.10.2004) US

(84) Designated States (unless otherwise indicated, for every kind of regional protection available): ARIPO (BW, GH, GM, KE, LS, MW, MZ, NA, SD, SL, SZ, TZ, UG, ZM, ZW), Eurasian (AM, AZ, BY, KG, KZ, MD, RU, TJ, TM), European (AT, BE, BG, CH, CY, CZ, DE, DK, EE, ES, FI, FR, GB, GR, HU, IE, IS, IT, LT, LU, LV, MC, NL, PL, PT, RO, SE, SI, SK, TR), OAPI (BF, BJ, CF, CG, CI, CM, GA, GN, GQ, GW, ML, MR, NE, SN, TD, TG).

(71) Applicant (for all designated States except US): AUTO-LIV ASP, INC. [US/US]; 3350 Airport Road, Ogden, Utah 84405 (US).

(72) Inventors; and

(75) Inventors/Applicants (for US only): WILLIAMS, Jeffrey D. [US/US]; 5155 South 3025 West, Roy, Utah 84067 (US). ROSE, Larry D. [US/US]; 2023 East Cedar Loop Drive, South Weber, Utah 84405 (US). SMITH, Bradley W. [US/US]; 1035 North 3650 West, Ogden, Utah 84404 (US). JORDAN, Michael P. [US/US]; 8140 South Cedar Circle, South Weber, Utah 84405 (US). JAMISON, Patrick D. [US/US]; 248 West 3450 North, North Ogden, Utah 84414 (US).

Published:

— without international search report and to be republished upon receipt of that report

For two-letter codes and other abbreviations, refer to the "Guidance Notes on Codes and Abbreviations" appearing at the beginning of each regular issue of the PCT Gazette.

(54) Title: AIRBAG CUSHION WITH CINCH TUBE FOR REDUCED OUT-OF-POSITION EFFECTS

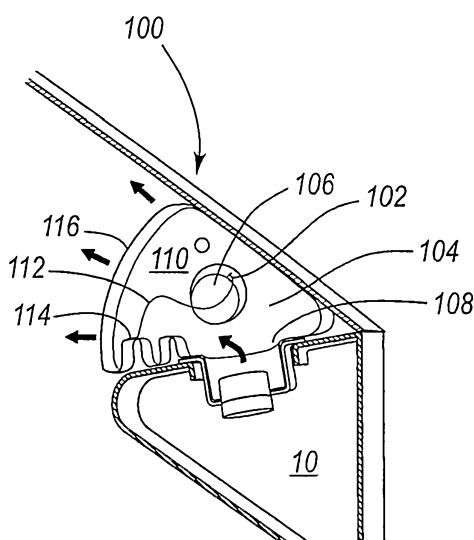

(57) Abstract: An airbag cushion is disclosed for use in automotive protective systems. The airbag cushion includes a tube that may be restricted to prevent gas venting. A cord is coupled to the tube and to a surface of the cushion. Upon airbag deployment, the cord extends until taut or extends until the cushion encounters an obstruction. If pulled taut, the cord tightens the tube and restricts gas venting. If the cushion encounters an obstruction, the cord remains lax and the tube is able to vent gas.

WO 2006/041552 A2

AIRBAG CUSHION WITH CINCH TUBE FOR REDUCED
OUT-OF-POSITION EFFECTS

Technical Field

[0001] The present invention relates generally to the field of automotive
5 protective systems. More specifically, the present invention relates to inflatable
airbags for automobiles.

Summary of the Invention

[0001A] The present invention provides an airbag cushion module,
comprising:

10 an inflatable airbag cushion defining an interior;
a cinch tube having a base end opposite from a terminal end,
wherein the terminal end has an aperture; and
a cinch cord coupled to the terminal end of the cinch tube and
extending around a majority of the aperture of the terminal end of the
15 cinch tube, the cinch cord further coupled to a surface of the airbag
cushion such that upon inflatable airbag deployment with obstruction, the
cinch cord does not fully extend and the cinch tube remains open, and
upon inflatable airbag deployment without obstruction, the cinch
cord extends and at least partially closes the aperture at the terminal
20 end,

wherein the cinch tube is configured such that the aperture
at the terminal end at least partially closes, upon inflatable airbag
deployment without obstruction, without necessitating closure of
the base end of the cinch tube, and

wherein the configuration of the cinch tube and the length of the cinch cord enables the aperture to at least partially close, upon inflatable airbag deployment without obstruction, such that the terminal end is at least partially within the interior of the inflatable airbag cushion after the aperture becomes at least partially closed.

[0001B] The present invention also provides an airbag cushion module, comprising:

an inflatable airbag cushion defining an interior;

a first cinch tube and a second cinch tube, wherein each cinch tube has a base end opposite from a terminal end, and each terminal end has an aperture; and

a cinch cord coupled to the first and second cinch tubes and extending around a majority of the aperture of the terminal end of each of the cinch tubes;

wherein the cinch cord passes through a cinch loop coupled to a surface of the airbag cushion at a location such that upon inflatable airbag deployment with obstruction, the cinch cord does not fully extend and the cinch tubes remain open, and

upon inflatable airbag deployment without obstruction, the cinch cord extends and at least partially closes the apertures of the terminal ends of the cinch tubes;

wherein the cinch tubes are configured such that the apertures at the terminal ends at least partially closes, upon

inflatable airbag deployment without obstruction, without necessitating closure of the base ends of the cinch tubes, and wherein the configuration of the cinch tubes and the length of the cinch cord enables the apertures to at least partially close, upon inflatable airbag deployment without obstruction, such that the terminal ends are at least partially within the interior of the inflatable airbag cushion after the apertures becomes at least partially closed.

[0001C] The invention further provides an airbag cushion module, comprising:

an inflatable airbag cushion defining an interior;
means for venting gas out of the airbag; and
means for restricting gas venting by cinching the venting means to reduce the circumference of the venting means at a terminal end without necessitating closure of an opposing base end upon inflatable airbag deployment without obstruction and enabling the venting means to remain open upon inflatable airbag deployment with obstruction, wherein the configuration of the venting means and configuration of the means for restricting gas venting enable the venting means to at least partially close, upon inflatable airbag deployment without obstruction, such that the terminal end is at least partially within the interior of the inflatable airbag cushion after the venting means becomes at least partially closed.

Brief Description of the Drawings

[0002] Understanding that drawings depict only typical embodiments of the invention and are not therefore to be considered to be limiting of its scope, the

invention will be described and explained with additional specificity and detail through the use of the accompanying drawings in which:

[0003] FIG. 1A is a cross-sectional view of an embodiment of a deploying airbag cushion.

5 **[0004]** FIG. 1B is a cross-sectional view of the deploying airbag cushion of FIG. 1A

[0005] FIG. 1C is a cross-sectional view of an embodiment of a deploying airbag cushion of FIGS 1A and 1B.

[0006] FIG. 2A is a perspective view of an embodiment of a cinch tube.

10 **[0007]** FIG. 2B is a perspective view of the cinch tube of FIG. 2A.

[0008] FIG. 3 is a perspective view of another embodiment of a cinch tube.

[0009] FIG. 4 is a perspective view of an additional embodiment of a cinch tube.

[0010] FIG. 5A is a cross-sectional view illustrating initial deployment of an airbag cushion.

[0011] FIG. 5B is a cross-sectional view illustrating a deploying airbag cushion.

5 [0012] FIG. 5C is a cross-sectional view of a deployed airbag cushion.

[0013] FIG 5D is a cross-sectional view illustrating initial deployment of an airbag cushion.

[0014] FIG. 5E is a cross-sectional view illustrating a deploying airbag cushion.

10 [0015] FIG 5F is a cross-sectional view of a deployed airbag cushion.

[0016] FIG 6 is a diagram illustrating an airbag cushion venting graph in relation to an airbag cushion's deployment.

[0017] FIG. 7 is a cross-sectional view of an alternative embodiment of a deployed airbag cushion.

15 [0018] FIG. 8 is a side view of one embodiment of a cinch tube.

[0019] FIG. 9 is a side view of another embodiment of a cinch tube.

Detailed Description of Preferred Embodiments

[0020] Described below are embodiments of an airbag cushion and venting mechanism. As those of skill in the art will appreciate, the principles of the invention may be applied to and used with a variety of airbag deployment systems including frontal driver and passenger airbags, knee airbags, overhead airbags, curtain airbags, and the like. Thus, the present invention is applicable to airbag cushions of various shapes and sizes.

20

Airbag cushions are frequently located in an instrument panel and directly in

front of an occupant. During a collision, the airbag cushion inflates and
deploys through a cosmetic cover. The airbag cushion deploys towards the
occupant and provides a restraint. A dangerous situation occurs where an
occupant is positioned too closely to the airbag which causes the occupant to
5 contact the airbag as it is deploying. Ideally, the occupant should be in position
to contact the airbag only after full deployment. It would be advantageous to
provide an airbag with a softer deployment when an occupant is out-of-position.
Embodiments described below

provide an airbag cushion that responds to an occupant's position and vents accordingly to avoid excessive deploying impact.

[0020] Embodiments disclosed herein include a cinch cord that is connected at one end to a cinch tube and at an opposing end to an interior surface of the cushion. If an occupant is in close proximity to the deploying airbag and restricts normal inflation, the cinch tube remains open and allows gas to rapidly escape. If the occupant is in a normal position and inflation is unrestricted, the tension pulls on the cinch tube to quickly close the cinch tube. Closure retains gas for normal occupant restraint. Thus, the cinch tube may be used as a variable feature in out-of-position conditions and in normal restraint conditions. In this manner, the airbag cushion is sensitive to obstructive expansion of the cushion.

[0021] With reference now to the accompanying figures, particular embodiments of the invention will now be described in greater detail. FIGS. 1A through 1C depicts a cross-sectional view of an airbag cushion 100 deploying from a housing 10. The airbag cushion 100 includes a cinch tube 102 that may include a nylon woven fabric-type or other suitable material known in the art. The cinch tube 102 may be embodied with a generally cylindrical shape and having opposing open ends to enable gas venting. The cinch tube 102 may have any suitable shape such as rectangular, triangular, or polygon shapes. The cinch tube 102 may be embodied with a height that is sufficient to achieve desired closure.

[0022] The cinch tube 102 is coupled to a surface 104 of the airbag cushion 100 and circumvents an aperture 106 in the surface 104. The surface 104 may form part of an airbag cushion throat 108 or may be proximate to the throat 108. The cinch tube 102 may extend into the airbag cushion interior 110 or may extend from the airbag cushion 100. For illustrative purposes, a single cinch tube 102 is disclosed

but the airbag cushion 100 may include multiple cinch tubes to provide required venting capability.

[0023] The airbag cushion 100 includes a cinch cord 112 that couples or engages the cinch tube 102 and couples to a surface 114 of the airbag cushion 100. The cinch cord 112 may include a nylon material or other suitable material known in the art. The surface 114 may be an interior surface of the airbag cushion as depicted. The surface 114 may be the surface opposing the face surface 116 of the airbag cushion that contacts the occupant. Alternatively, the surface 114 may be disposed proximate to a surface opposing the face surface 116. The surface 114 may be an exterior surface such as the face surface 116. Thus, the cinch cord 112 may extend through the interior 110 of the airbag cushion 100 or may be positioned exterior to the airbag cushion 100. The location of the surface 114 depends on module deployment angle, vehicle interior geometry, and cushion fold type.

[0024] In FIG. 1A, the initially deploying airbag cushion 100 has a slack cinch cord 112 and the cinch tube 102 remains open. In FIG. 1B, the cinch cord 112 is pulled taut and the cinch tube 102 begins to close. In FIG. 1C, the cinch cord 112 is completely taut and the cinch tube 102 is closed.

[0025] Referring to FIGS. 2A and 2B, perspective views of one embodiment of a cinch tube 102 in both the open and closed positions are shown. The cinch cord 112 circumvents a majority of the perimeter 200 of the cinch tube 102 in order to properly tighten and restrict the cinch tube 102. The cinch cord 112 has a length that includes an initial free length and a circumference of the cinch tube 102. The cinch cord 112 may be disposed within a sleeve 202 that is formed within the cinch tube 102. Access to the sleeve 202 is through a sleeve aperture 204 formed in the cinch tube 102. The cinch cord 112 enters the sleeve aperture 204, feeds through the

sleeve 202, and is coupled at an end 206 within the sleeve 120 to the cinch tube 102. Coupling may be achieved by stitches, bonds, or adhesives.

[0026] Referring to FIG. 3, an alternative embodiment of a cinch tube 300 is shown wherein a cinch cord 302 loops around the majority of the cinch tube perimeter 304. The cinch tube 300 includes first and second sleeve apertures 306, 308 that are in communication with a sleeve 310 formed within the cinch tube 300. The cinch cord 302 enters the first sleeve aperture 306, extends along the sleeve 310, and exits out the second sleeve aperture 308.

[0027] Referring to FIG. 4, an alternative embodiment of a cinch tube 400 is shown wherein the cinch tube 400 includes a plurality of cinch loops 402. The cinch loops 402 may be disposed on a periphery 404 as shown or on an inner or outer surface 406, 408 of the cinch tube 400. A cinch cord 410 is fed through the cinch loops 402 and is thereby able to restrict the cinch tube 400 as needed.

[0028] Figures 5A-C illustrate three stages of a deploying airbag cushion 500 without obstruction in the deploying path. The depicted airbag cushion 500 includes two cinch tubes 502 symmetrically disposed on the cushion 500 and two vents 504 symmetrically disposed on the cushion 500. The vents 504 provide consistent venting of the airbag cushion 500 and are not restricted by an occupant's position. The vents 504 may be optional in certain cushion embodiments based on venting requirements. The locations for the cinch tubes 502 and vents 504 may vary as does the number of tubes 502 and vents 504. An occupant 12 is in a normal seating position which will allow the airbag cushion 500 to fully expand before impacting the occupant. In this manner, the occupant 12 benefits from the full restraint capability of the airbag cushion 500.

[0029] In FIG. 5A, the initial breakout of the airbag cushion 500 occurs. The cinch tubes 502 are open and, in the depicted embodiment, extend from the airbag cushion 500. In FIG. 5B, cinch cords 506 corresponding to each cinch tube 502 are pulled taut and the cinch tubes 502 are restricted. The cinch tubes 502 may also be pulled within the interior 508 of the airbag cushion 500. In FIG. 5C, the cinch tubes 502 are completely closed, the gas vents through the vents 504, and normal restraint is provided to the occupant 12.

[0030] Figures 5D-F illustrate three stages of a deploying airbag cushion 500 with obstruction in the deploying path. An occupant 12 is out-of-position and obstructs the deploying airbag cushion 500 and prevents the airbag cushion 500 from fully inflating. In FIG. 5D, the airbag cushion 500 begins initial deployment as in FIG. 5A. In FIG. 5E, the airbag cushion 500 impacts the occupant 12 and the cinch cords 506 remain slack. The cinch tubes 502 remain open and venting rapidly occurs from tubes 502 and vents 504. The cushion inflation is restricted but the occupant 12 receives less than the full deployment loading of the cushion 500. In FIG. 5F, the cushion 500 is partially inflated and provides limited restraint. Venting continues through the tubes 502 and vents 504.

[0031] Referring to FIG. 6, a graph illustrating cinch tube venting as a function of airbag cushion displacement is shown. For reference, an airbag cushion 600 is shown in various stages of deployment. The airbag cushion 600 includes two symmetrically disposed cinch tubes 602. During initial deployment, the airbag cushion 600 is unfolding and the cinch tubes 602 provide little or no venting. The airbag cushion 600 expands into an out-of-position zone 604 where, if obstructed, the cinch tubes 602 will remain completely or nearly open and full venting occurs. In this zone an occupant does not receive the full restraint capability but does benefit

from limited restraint. If unobstructed, the airbag cushion 600 expands into a gray zone 606 where partial closure of the cinch tubes 602 begins and venting is limited. The cinch tubes 602 may be pulled into the airbag cushion 600 depending on the cushion design. If further unobstructed, the airbag cushion 600 fully expands to the restraint zone 608. At this zone, the cinch tubes 602 completely close and an occupant benefits from the full restraint capability of the airbag cushion 600.

[0032] Referring to FIG. 7, an alternative embodiment of an airbag cushion 700 is shown. The airbag cushion 700 includes two symmetrical cinch tubes 702 that may be embodied as described above. The cinch tubes 702 have been pulled completely into the airbag cushion interior 704. Rather than having cinch cords corresponding to each cinch tube 702, a single cinch cord 706 is used. The cinch cord 706 is coupled to or engages each cinch tube 702 in a manner similar to that previously described. The cinch cord 706 passes through a cord loop 708 that is coupled to an interior surface 710. The cord loop 708 may be formed of a fabric material similar or identical to that of the airbag cushion 700. The cinch cord 706 may freely pass through the loop 708 and may therefore be referred to as a "floating" cinch cord. In an alternative embodiment, the cinch cord 706 may be disposed on the airbag cushion exterior and passes through a cord loop 708 coupled to an exterior surface of the airbag cushion 700. In either embodiment, airbag cushion deployment pulls the cinch cord 706 taut and closes both cinch tubes 702.

[0033] Referring to FIG. 8, an alternative embodiment of a cinch cord 800 disposed within a cinch tube 802 is shown. The cinch tube 802 includes a sleeve 804 that extends around a periphery of the cinch tube 802 and houses a portion of the cinch cord 800. The cinch cord 800 exits from the sleeve 804 through a sleeve aperture 806. The cinch cord 800 includes a stopper 808 that, prior to airbag

cushion deployment, is disposed within the sleeve 804. The stopper 808 is sized and configured to permit deploying movement, i.e. from the sleeve 804 and through the aperture 806, but does restricts movement through the aperture 806. In operation, the stopper 808 prevents a cinch tube 802 from reopening after deployment and closure of the cinch tube 802. This may occur during deflation of an airbag cushion as the cinch cord becomes slack. Venting is thereby directed to other vents.

[0034] Referring to FIG. 9, an alternative embodiment of a cinch tube 900 is shown with a cinch cord 902 partially disposed within. The cinch tube 900 includes a sleeve 904 that contains a portion of the cinch cord 902. The cinch tube 900 further includes tack stitching 906 that is inserted through the sleeve 904 and the cinch cord 902 to retain the cinch cord 902 and prevent inadvertent closing of the cinch tube 900 during shipping and handling. The tack stitching 906 is designed to be easily broken and provides no interference to airbag cushion deployment.

[0035] Embodiments disclosed herein illustrate novel techniques for venting an airbag cushion to retain an open vent when an occupant obstructs the path of a deploying cushion and closed when an occupant does not obstruct a deploying cushion. Airbag cushions provide improved safety by deploying with less pressure when an occupant is obstructing deployment. The airbag cushions deploy with more pressure when an occupant is not obstructing deployment and when high pressure is required to provide the necessary restraint. The airbag cushions described herein have application to both driver and passenger positions. Furthermore, the airbag cushions may be configured in a variety of sizes based on design constraints.

[0036] Various embodiments for cinch tubes have been disclosed herein. Cinch tubes 102, 300, 400, 502, 602, 702, 802, and 900 are examples of means for venting

gas out of the airbag and circumventing an aperture disposed in the airbag. Cinch cords 112, 302, 410, 506, 706, 800, and 902 are examples of means for restricting gas venting by cinching the venting means to reduce the circumference of the venting means upon inflatable airbag deployment without
5 obstruction and enabling the venting means to remain open upon inflatable airbag deployment with obstruction.

[0037] It will be apparent to those having skill in the art that changes may be made to the details of the above-described embodiments without departing from the underlying principles of the invention. Embodiments of the invention in
10 which an exclusive property or privilege is claimed are defined as follows.

[0038] In the claims which follow and in the preceding description of the invention, except where the context requires otherwise due to express language or necessary implication, the word "comprise" or variations such as "comprises" or "comprising" is used in an inclusive sense, i.e. to specify the
15 presence of the stated features but not to preclude the presence or addition of further features in various embodiments of the invention.

[0039] It is to be understood that, if any prior art publication is referred to herein, such reference does not constitute an admission that the publication forms a part of the common general knowledge in the art, in Australia or any
20 other country.

Claims

1. An airbag cushion module, comprising:

5 an inflatable airbag cushion defining an interior;

a cinch having a base end opposite from a terminal end, wherein the terminal end has an aperture; and

a cinch cord coupled to the terminal end of the cinch tube and extending around a majority of the aperture of the terminal end of the cinch tube, the cinch cord further coupled to a surface of the airbag cushion such that upon inflatable airbag deployment with obstruction, the cinch cord does not fully extend and the cinch tube remains open, and upon inflatable airbag deployment without obstruction, the cinch cord extends and at least partially closes the aperture at the terminal end,

15 wherein the cinch tube is configured such that the aperture at the terminal end at least partially closes, upon inflatable airbag deployment without obstruction, without necessitating closure of the base end of the cinch tube, and

20 wherein the configuration of the cinch tube and the length of the cinch cord enables the aperture to at least partially close, upon inflatable airbag deployment without obstruction, such that the terminal end is at least partially within the interior of the inflatable airbag cushion after the aperture becomes at least partially closed.

25

2. The airbag cushion module of claim 1, wherein the cinch tube includes,

a sleeve extending around the majority of the aperture of the terminal end of the cinch tube and housing a portion of the cinch cord; and

5 a sleeve aperture in communication with the sleeve and through which the cinch cord passes.

3. The airbag cushion module of claim 2, further comprising a stopper coupled to the cinch cord and disposed within the sleeve prior to airbag
10 deployment, the stopper adapted to pass through the sleeve aperture upon airbag deployment and resisting entry into the sleeve aperture after airbag deployment.

4. The airbag cushion module of claim 2, further comprising a tack
15 stitch inserted into the sleeve and the cinch cord.

5. The airbag cushion module of claim 2, wherein the cinch tube includes a plurality of loops and wherein the cinch cord is disposed within the
20 loops.

6. The airbag cushion module of claim 1, wherein the surface coupled to the cinch cord is an internal surface of the inflatable airbag cushion
25 and the cinch cord is disposed within the interior of the inflatable airbag cushion.

7. The airbag cushion module of claim 1, wherein the surface coupled to the cinch cord is an external surface of the inflatable airbag cushion.

5

8. The airbag cushion module of claim 1, further comprising:

a second cinch tube having a base end opposite from a terminal end, wherein the terminal end has an aperture; and

10

a second cinch cord coupled to the terminal end of the second cinch tube and extending around a majority of the aperture of the terminal end of the second cinch tube, the second cinch cord further coupled to a surface of the airbag cushion such that upon inflatable airbag deployment with obstruction, the second cinch cord does not fully extend and the second cinch tube remains open, and

15

upon inflatable airbag deployment without obstruction, the second cinch cord extends and at least partially closes the aperture at the terminal end without necessitating closure of the base end of the second cinch tube;

20

wherein the second cinch tube is configured such that the aperture at the terminal end of the second cinch tube at least partially closes, upon inflatable airbag deployment without obstruction, without necessitating closure of the base end of the second cinch tube, and

25

wherein the configuration of the second cinch tube and the length of the second cinch cord enables the aperture to at least partially close, upon inflatable airbag deployment without obstruction, such that the terminal end of the second cinch tube is at least partially within the

interior of the inflatable airbag cushion after the aperture of the second cinch tube becomes at least partially closed.

5 9. The airbag cushion module of claim 1, further comprising a vent disposed on the airbag cushion and adapted to vent gas during airbag deployment with and without obstruction.

10 10. An airbag cushion module, comprising:
an inflatable airbag cushion defining an interior;
a first cinch tube and a second cinch tube, wherein each cinch tube has a base end opposite from a terminal end, and each terminal end has an aperture; and
a cinch cord coupled to the first and second cinch tubes and
15 extending around a majority of the aperture of the terminal end of each of the cinch tubes;
wherein the cinch cord passes through a cinch loop coupled to a surface of the airbag cushion at a location such that upon inflatable airbag deployment with obstruction, the cinch cord
20 does not fully extend and the cinch tubes remain open, and
upon inflatable airbag deployment without obstruction, the cinch cord extends and at least partially closes the apertures of the terminal ends of the cinch tubes;
wherein the cinch tubes are configured such that the
25 apertures at the terminal ends at least partially closes, upon

inflatable airbag deployment without obstruction, without necessitating closure of the base ends of the cinch tubes, and

wherein the configuration of the cinch tubes and the length of the cinch cord enables the apertures to at least partially close,

5 upon inflatable airbag deployment without obstruction, such that the terminal ends are at least partially within the interior of the inflatable airbag cushion after the apertures becomes at least partially closed.

10 11. The airbag cushion module of claim 10, wherein the first and second cinch tubes each include,

a sleeve extending around the majority of the aperture of the terminal end of the cinch tube and housing a portion of the cinch cord; and

15 a sleeve aperture in communication with the sleeve and through which the cinch cord passes.

20 12. The airbag cushion module of claim 11, further comprising a first stopper coupled to the cinch cord and disposed within the sleeve of the first cinch tube and a second stopper coupled to the cinch cord and disposed within the sleeve of the second cinch tube, the first and second stoppers adapted to pass through corresponding sleeve apertures upon airbag deployment and resisting entry into the sleeve apertures after airbag deployment.

13. The airbag cushion module of claim 11, further comprising tack stitches inserted into the sleeves of the first and second cinch tubes and the cinch cord.

5

14. The airbag cushion module of claim 10, wherein the first and second cinch tubes each include a plurality of loops and wherein the cinch cord is disposed within the loops.

10

15. The airbag cushion module of claim 10, wherein the surface coupled to the cinch loop is an interior surface of the inflatable airbag cushion and the cinch cord is disposed within the interior of the inflatable airbag cushion.

15

16. The airbag cushion module of claim 10, wherein the surface coupled to the cinch cord is an external surface of the inflatable airbag.

20

17. The airbag cushion module of claim 8 or 10, wherein the first and second cinch tubes are symmetrically disposed on the airbag cushion.

25

18. The airbag cushion module of claim 10, further comprising a vent disposed on the inflatable airbag cushion and adapted to vent gas during airbag deployment with and without obstruction.

30

19. An airbag cushion module, comprising:
an inflatable airbag cushion defining an interior;

means for venting gas out of the airbag; and

means for restricting gas venting by cinching the venting means to reduce the circumference of the venting means at a terminal end without necessitating closure of an opposing base end upon inflatable airbag deployment without obstruction and enabling the venting means to remain open upon inflatable airbag deployment with obstruction,

wherein the configuration of the venting means and configuration of the means for restricting gas venting enable the venting means to at least partially close, upon inflatable airbag deployment without obstruction, such that the terminal end is at least partially within the interior of the inflatable airbag cushion after the venting means becomes at least partially closed.

20. An airbag cushion, substantially as herein described with reference to the accompanying drawings.

1/7

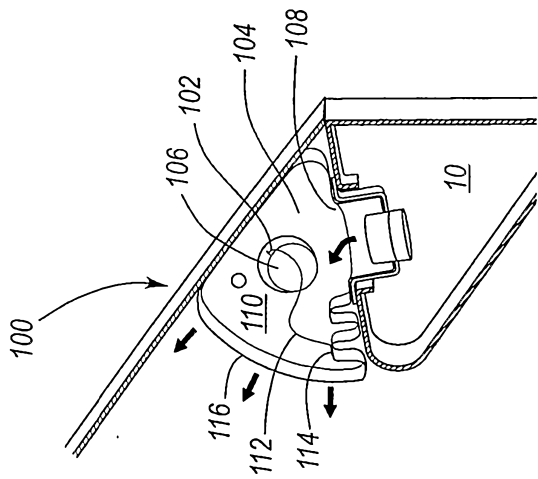
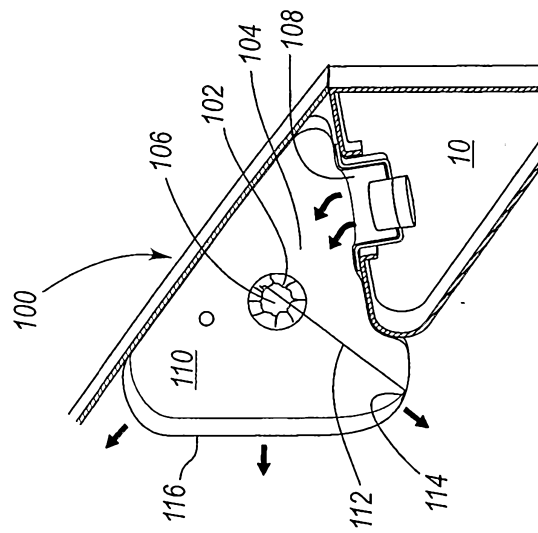
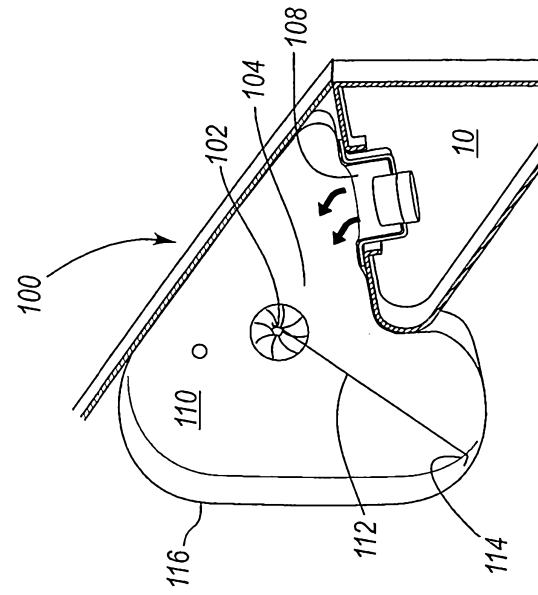

Fig. 1C

Fig. 1B

Fig. 1A

2/7

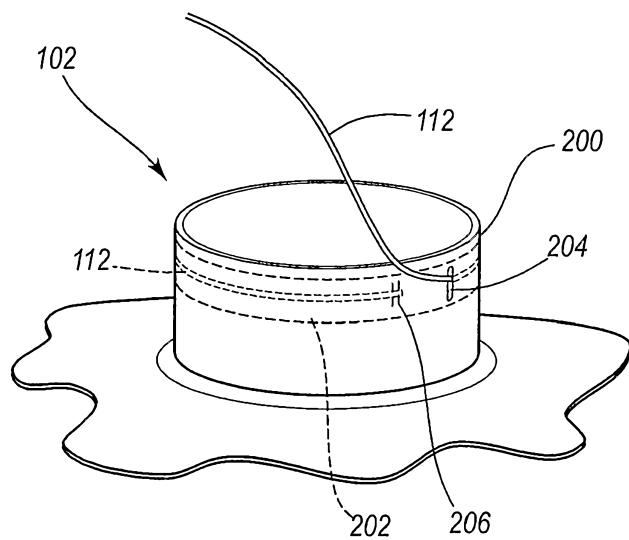

Fig. 2A

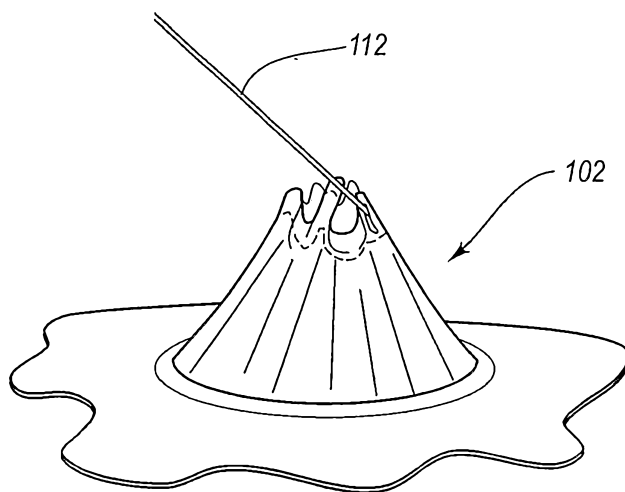

Fig. 2B

3/7

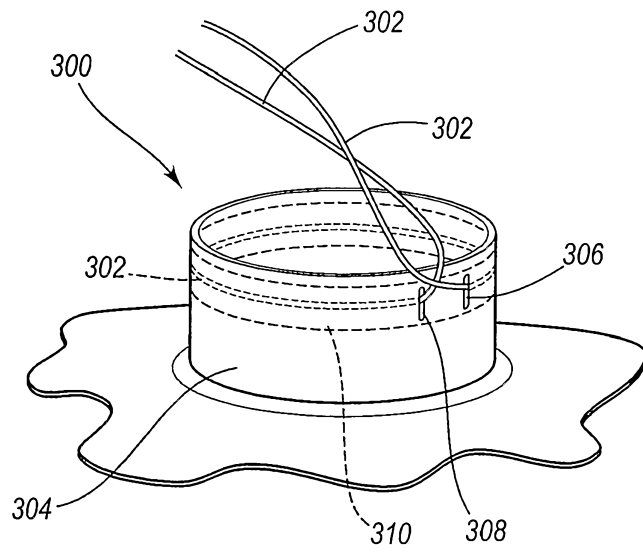

Fig. 3

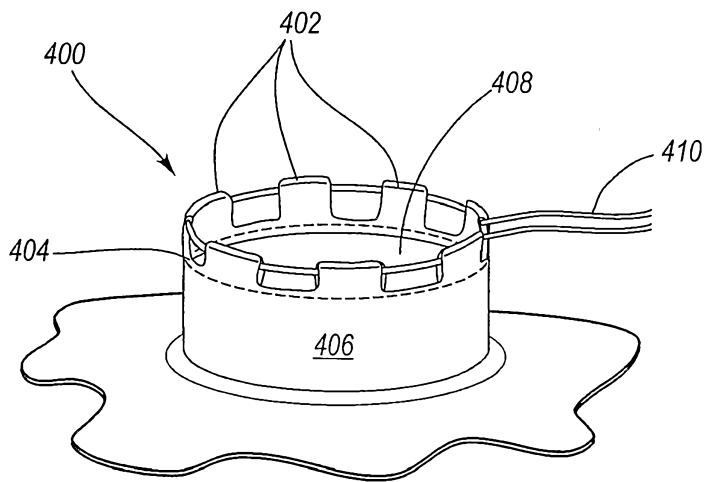

Fig. 4

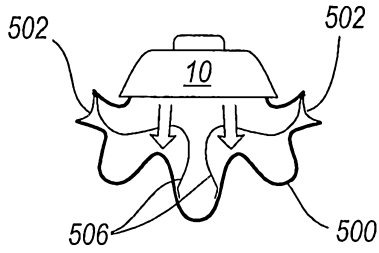

Fig. 5A

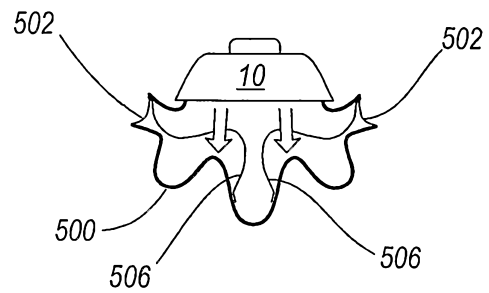

Fig. 5D

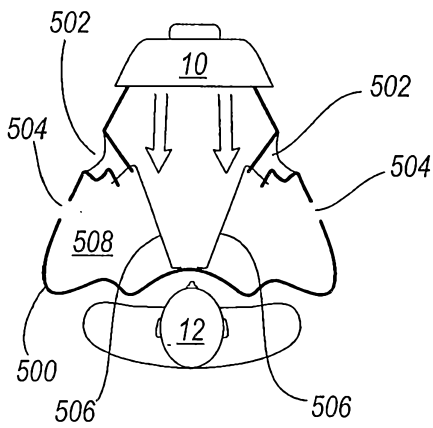

Fig. 5B

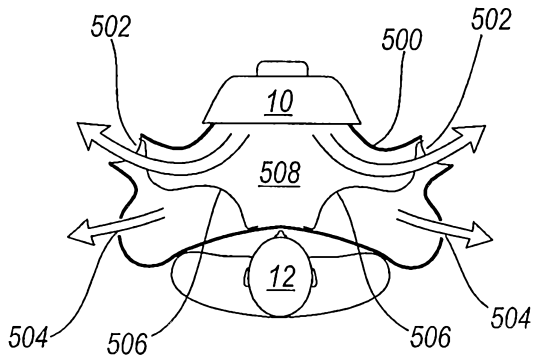

Fig. 5E

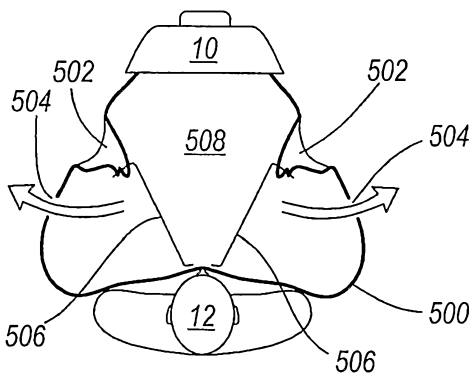

Fig. 5C

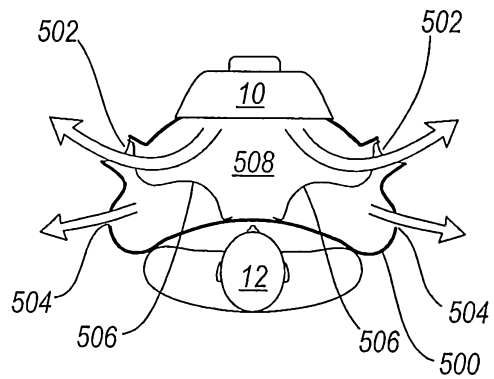

Fig. 5F

5 / 7

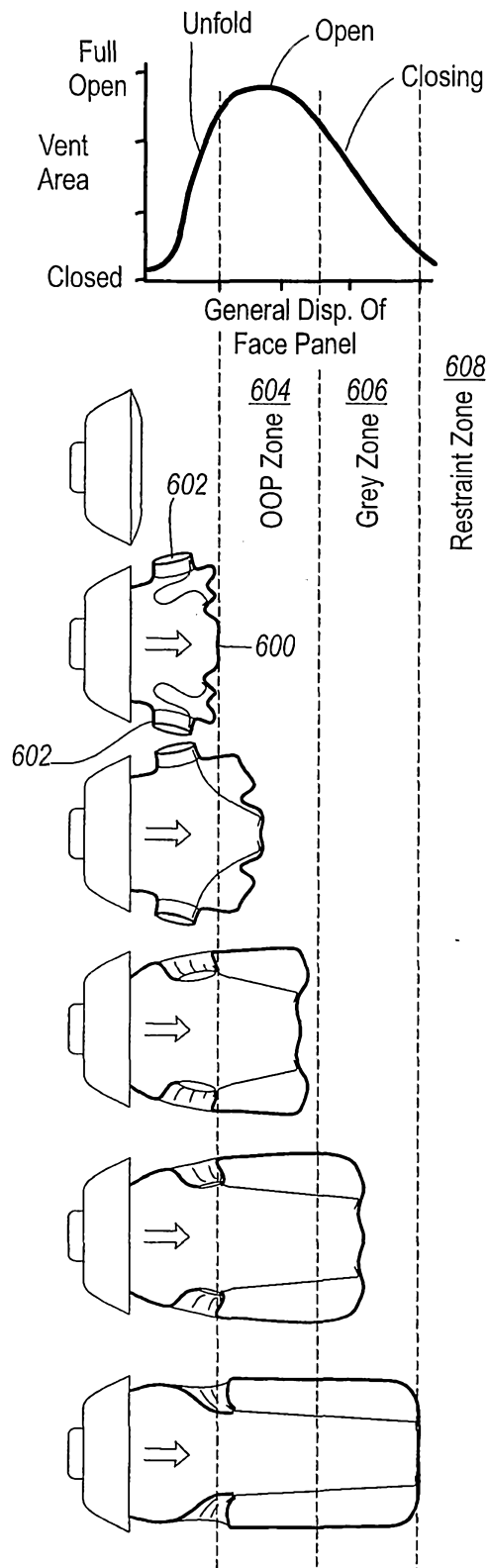

Fig. 6

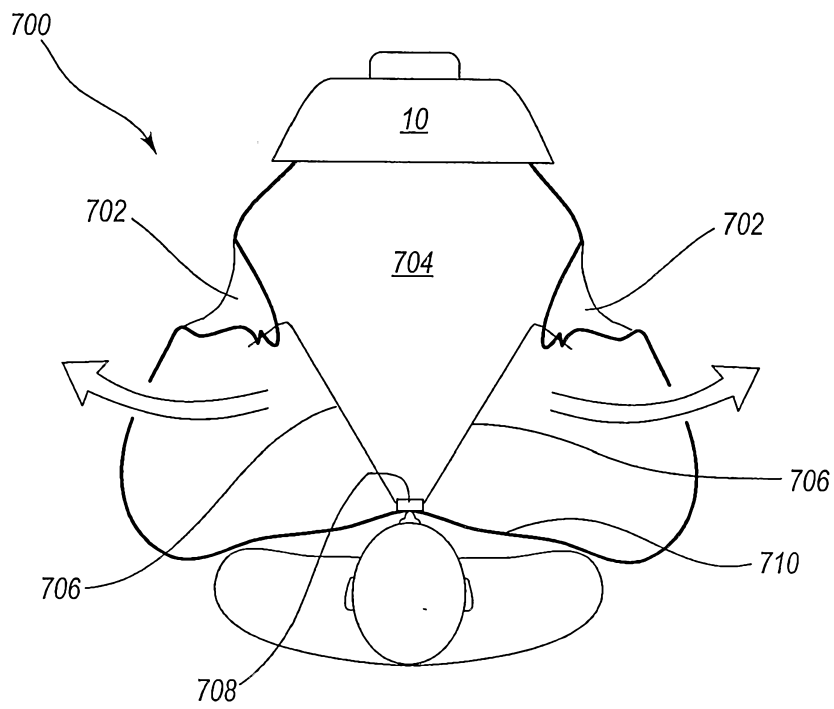

Fig. 7

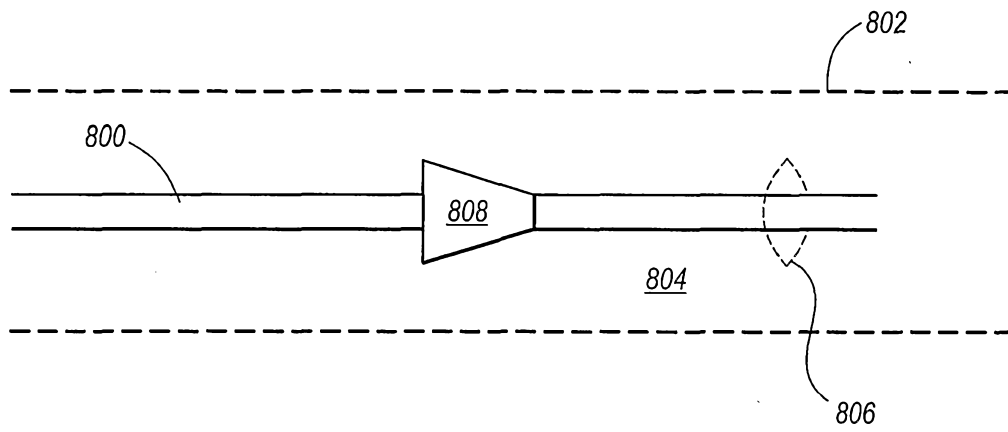

Fig. 8

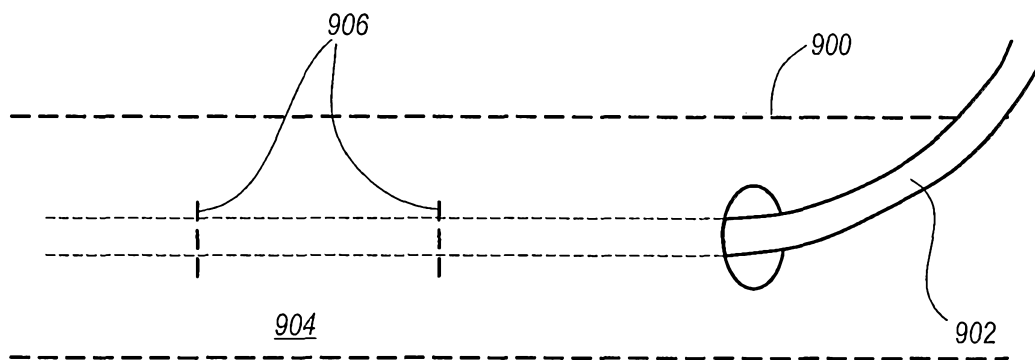

Fig. 9