

(No Model.)

3 Sheets—Sheet 2.

J. F. DUSTIN.
LOOM.

No. 594,684.

Patented Nov. 30, 1897.

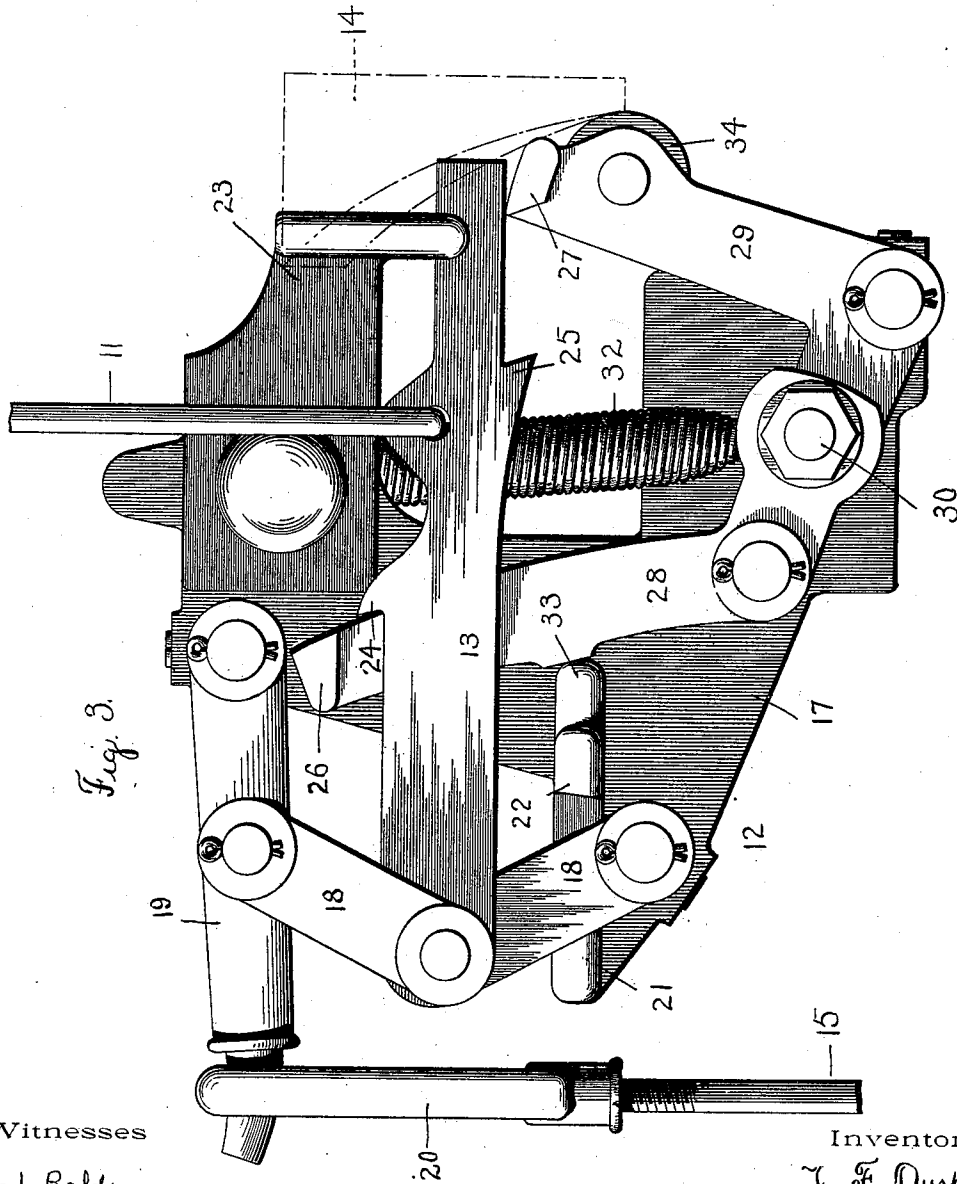

Fig. 3.

Witnesses

W. J. Baldwin.
E. M. Healy.

Inventor.

J. F. Dustin
By
Southgate & Southgate
Attorneys.

(No Model.)

3 Sheets—Sheet 3.

J. F. DUSTIN.
LOOM.

No. 594,684.

Patented Nov. 30, 1897.

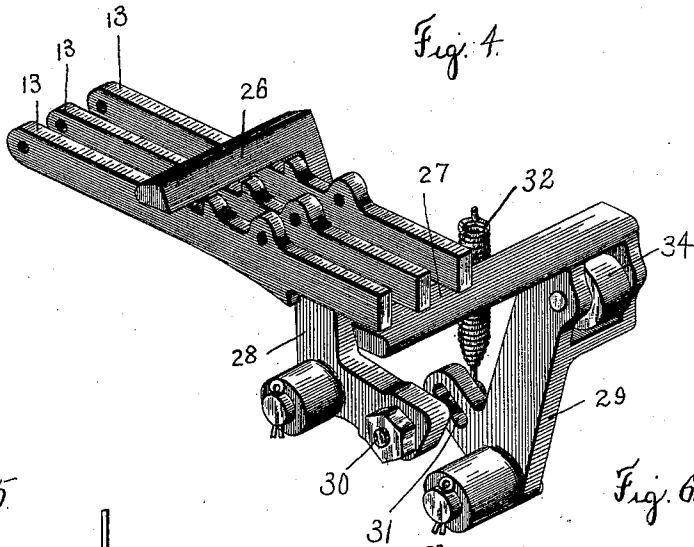

Fig. 4.

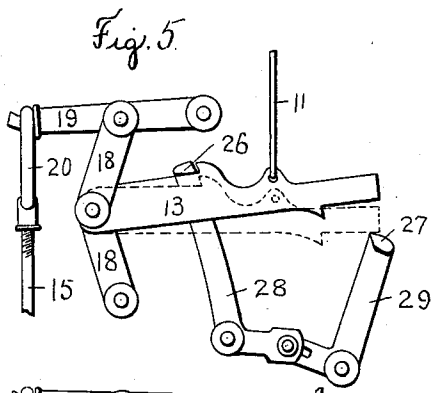

Fig. 5.

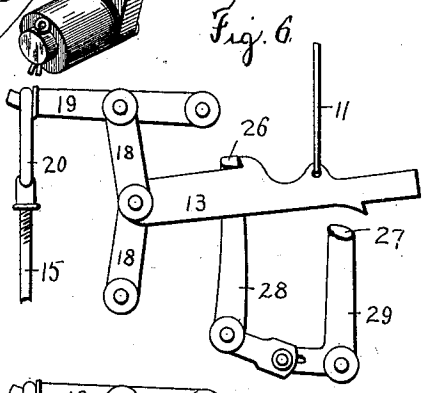

Fig. 6.

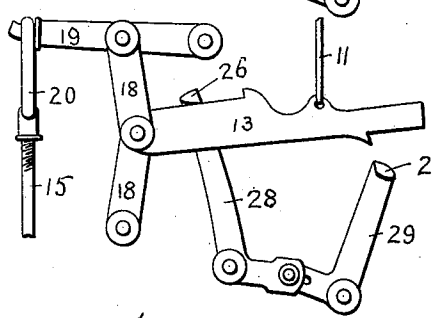

Fig. 7.

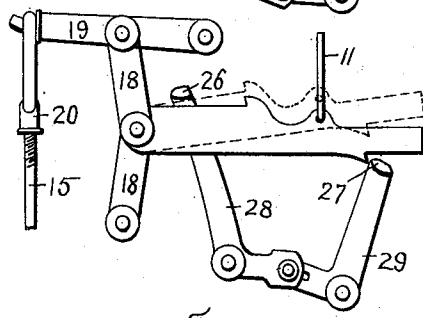

Fig. 8.

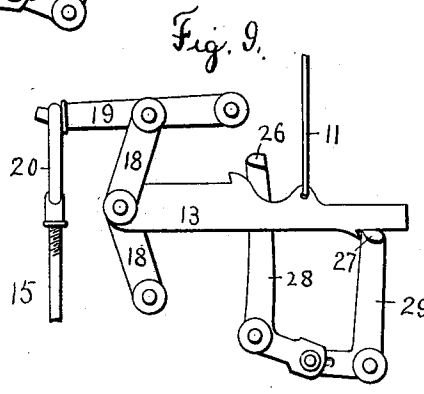

Fig. 9.

Witnesses.
W. J. Baltimore
E. M. Healy.

Inventor.
J. F. Dustin
By Southgate & Southgate
Attorneys.

UNITED STATES PATENT OFFICE.

JOHN F. DUSTIN, OF FITCHBURG, MASSACHUSETTS, ASSIGNOR TO HIMSELF
AND THE PARKHILL MANUFACTURING COMPANY, OF SAME PLACE.

LOOM.

SPECIFICATION forming part of Letters Patent No. 594,684, dated November 30, 1897.

Application filed February 9, 1897. Serial No. 622,621. (No model.)

To all whom it may concern:

Be it known that I, JOHN F. DUSTIN, a citizen of the United States, residing at Fitchburg, in the county of Worcester and State of Massachusetts, have invented a new and useful Improvement in Looms, of which the following is a specification.

The objects of my invention are, first, to provide a simple, compact, and efficient box-motion-operating device for looms, and, in the second place, to arrange the pattern devices or chains which control the harness and box motions of a loom, respectively, so that said pattern devices or chains will move together, so that when one chain is advanced or moved back the second chain will be correspondingly shifted.

To these ends my invention consists of the parts and combinations of parts, as hereinafter described, and more particularly pointed out in the claims at the end of this specification.

In the accompanying drawings, Figure 1 is an end view of a loom, sufficient parts thereof being shown to illustrate the application of my invention. Figs. 1^a and 1^b are detail views illustrating a slightly-modified form of construction. Fig. 2 is a detail sectional view to be hereinafter referred to. Fig. 3 is a front view of a box-motion-operating device constructed according to my invention. Fig. 4 is a perspective view illustrating the relative position of the hook-pieces and operating blades or sweeps therefor; and Figs. 5 to 9, inclusive, are diagrammatic views illustrating the operation of the device.

The ordinary forms of dobby-loom now usually employed in cotton-weaving embody two distinct pattern mechanisms. One pattern mechanism through a harness-motion controls the position of the warp-threads, and the other pattern mechanism is arranged to control the box-motion which governs the weft or filling threads. These two pattern mechanisms, which control the warp-threads and the weft or filling threads, respectively, have heretofore ordinarily been independently mounted, so that either of them could be advanced or turned back without affecting the other. The pattern which is produced in the fabric woven by a loom depends upon

the correct joint action of the two pattern mechanisms which control the warp-threads and the weft-threads, respectively.

In ordinary constructions it has heretofore been necessary for the operator or weaver to independently adjust the two pattern mechanisms and to bring them into proper relation with each other before starting up the loom after the same has been stopped for any reason. For example, in the ordinary forms of gingham or fancy looms the warps are controlled by means of a dobby-cylinder and chain, and the box-motion thereof is controlled by an independent pattern-chain located at some distance from the dobby and which can be turned back or shifted without affecting the dobby. When the loom is stopped, for example, by the weft stop-motion upon the exhaustion of a shuttle-bobbin, it is now the practice for the weaver to turn back the dobby-cylinder one peg and then by an independent operation to turn back one peg on the pattern-chain which controls the box-motion. A new shuttle can then be introduced and the loom again started in operation. If, however, it should happen that the dobby-cylinder should be turned back one peg while the pattern-chain which controls the box-motion should be perhaps turned back two pegs or not turned at all and the loom should then be started up, it would result in the entire confusion of the pattern which is being produced by the loom.

The especial object of my invention is therefore to provide a box-motion-operating attachment which may be applied to the ordinary dobby-loom now employed in cotton-weaving, so that the pattern-chains or mechanisms which control the weft or filling threads and the pattern-chains or mechanisms which control the warp-threads will move together, so that when one pattern device or chain is advanced or turned back the other chain will be correspondingly shifted; and my invention consists of a box-motion-operating device comprising a series of toggle levers or links, lifting-levers actuated thereby, hook-pieces connected to the toggle levers or links, and actuating blades or sweeps arranged to be moved toward each other by a cam and to be separated by a spring, and as thus con-

constructed my device can be applied with comparatively little trouble to looms already in use, and as the same is cam-actuated it can be readily timed to perform its function without interfering with the operation of the other essential parts of the machine.

Referring to the drawings and in detail, A designates one of the side frames of a loom, which may be of any ordinary or approved construction.

Journalled in the side frames A is one of the power-shafts *b*, having a pinion *c*, which meshes with and drives a gear *d*, secured upon a shaft *e*, journalled in the side frame of the loom. The gear *d* forms a crank-disk, which by means of a pitman *f* is connected to operate the levelers controlling the harness-motion.

Mounted on the shaft *e* is a bevel-gear *g*, which meshes with and drives a bevel-gear *h*, secured upon a vertical shaft *i*, which shaft *i* may be provided with a worm meshing with and driving a worm-wheel *j*, which worm-wheel *j* is connected to the dobbie-cylinder *l* by means of a spring-clutch *k*. The spring-clutch *k* allows the dobbie-cylinder *l* to be turned by the hand-wheel *m* independently of its driving connections, the parts of the clutch being normally held together by means of a spring coiled around the dobbie-cylinder shaft in the ordinary way.

The parts thus far referred to may be of any ordinary or approved construction and need not be herein described at length.

Mounted on the dobbie-cylinder *l* is a main pattern-chain *n*, which controls the harness-motion of the loom in the ordinary manner. Also mounted on the dobbie-cylinder *l*, near the inner end thereof, is a second pattern device or chain 10, which pattern-chain I employ for controlling my box-motion-actuating device.

As illustrated, the pattern-chain 10 coöperates with a plurality of fingers 16, in this instance three such fingers 16 being illustrated, which fingers are connected by means of lifting-wires 11 to the hook-pieces 13, which are mounted in and form part of my box-motion-operating mechanism 12.

In the construction of looms embodying my invention the dobbie-cylinder *l* may be made wide enough to coöperate with three additional fingers 16. In applying this form of construction to looms which employ dobbie-cylinders simply wide enough to coöperate with the number of fingers necessary to operate the harnesses thereof three of the fingers 16 will have to be disconnected from the harnesses and their harnesses thrown out of work if the pattern-chain 10 is made to run directly upon the dobbie-cylinder. In some cases it is therefore desirable to provide a distinct cylinder for the pattern-chain which controls the box-motion, and I have illustrated such a construction in Figs. 1^a and 1^b.

As shown in these figures, a supplemental cylinder 101, which is cored out, so as not to

interfere with the spring on the dobbie-cylinder shaft, may be secured in place by a set-screw, as shown, and the chain 100 for the box-motion may be trained thereover to coöperate with the fingers 160.

As shown most clearly in Fig. 1^b, the fingers 160 may be bent or offset, so as to bring their rear ends into position to coöperate with the lifting-wires 11.

Bolted upon the face of the leveler-operating crank-disk *d* is a face-cam 14, by means of which power will be applied to the box-motion-operating device 12.

The construction of the box-motion-operating device 12 is most clearly illustrated in Fig. 3. As shown, it comprises a framework or bracket 17, which may be bolted or secured to any convenient part of the framework of the loom. Mounted in the bracket 17 are toggle-joints formed by the toggle levers or links 18, which toggle-joints are connected to operate the lifting-levers 19. Secured upon the ends of the lifting-levers 19 are connecting-pieces 20, adjustably threaded into each of which is a lifting-rod 15.

As shown most clearly in Fig. 1, the lifting-rods 15 extend down to that part of the framework of the loom ordinarily occupied by the box-motion, and said lifting-rods may be connected at their lower ends either directly to operate the box-motion or to any form of multiplying devices now ordinarily employed in connection with such box-motions.

Extending from the bracket or frame 17, as shown in Fig. 3, are stops 21 and 22 for limiting the motion of the toggle-levers 18. The stop 22 is preferably located so that the toggle-joints may be thrown slightly past their centers of motion, as illustrated in Figs. 6 to 8, so that when the toggle-joints are in this position the lifting-levers will be locked in a raised position.

The hook-pieces 13, which connect to the toggle-joints, are provided on their upper edges with abutments 24 and on their lower edges with abutments 25. Near their outer ends the hook-pieces 13 pass through suitable slots in a guide piece or comb 23. Arranged to coöperate with the abutments 24 and 25, respectively, are actuating blades or sweeps 26 and 27. The actuating blades or sweeps 26 and 27 are carried by bell-crank levers 28 and 29, as most clearly illustrated in Fig. 4. The lower arms of the bell-crank levers 28 and 29 are connected by means of a pin 30, extending from the bell-crank lever 28 through a slot 31 in the bell-crank lever 29. A coiled spring 32 is connected at its lower end to the pin 30 and normally acts to open or separate the actuating blades or sweeps 26 and to hold the bell-crank lever 28 against a stop 33, as shown in Fig. 3. Journalled in the bell-crank lever 29, in position to engage the face-cam 14 before referred to, is a friction-roll 34. When the cam 14 engages with and acts upon its friction-roll 34, the actuating blades or sweeps 26 and 27 will be moved

toward each other from their normal position to that illustrated in Fig. 6.

The operation of a box-motion-actuating device as thus constructed is most clearly illustrated by Figs. 5 to 9, inclusive.

When a blank space on the pattern-chain 10 passes under one of the fingers 16, as illustrated in Fig. 2, the fingers 16 will pull up a lifter-wire 11 and raise a hook-piece 13 to the position illustrated in Fig. 5. When the actuating blades or sweeps 26 and 27 are moved toward each other by the action of the cam 14, the blade 26 will engage the upwardly-extending abutment of the lifted hook-piece 13, so that said hook-piece will be carried forward and the lifting-lever 19 will be raised, as illustrated in Fig. 6. The toggle-joint formed by the toggle links or levers 18 having been moved slightly past its center of motion, as illustrated, the parts will remain locked in this position as long as the hook-piece 13 is held up by its lifting-wire 11. When the hook-piece 13 is lowered, as illustrated in Fig. 8, the abutment on the lower side thereof will be brought into position to be engaged by the operating-blade 27, which will then act to restore the parts to their first position, as illustrated in Fig. 9.

If at any time the loom is stopped on account of the giving out of the weft-thread or for any other reason, the operator can turn back or advance the dobby-cylinder *l* by means of the hand-wheel *m*, and the pattern-chains *n* and 10 will move together, so that they will always maintain a correct cooperative relation; and I consider this an especially important feature of my invention, as a loom to which my attachments are applied is always in condition to be started, so that it will correctly weave a pattern.

I am aware that a mechanical movement comprising toggle levers or links, hook-pieces connected thereto, and reciprocating blades or sweeps for engaging said hook-pieces is not new, and that such a construction for operating the harness-motion of a loom is shown in the patent to Hattersley and Hill, No. 448,713, dated March 24, 1891, and I do not

claim such a construction broadly. My construction, however, is designed to operate a box-motion of a loom and differs from this, as my actuating blades or sweeps are actuated by means of a cam and spring, which fact enables me to time my construction so that the same has the quickness of motion requisite in a box-motion-operating device.

What I claim, and desire to secure by Letters Patent of the United States, is—

1. In a loom, the combination of a dobby-cylinder and its pattern-chain, a supplemental pattern-chain for controlling the box-motion mounted to turn with said dobby-cylinder, a box-motion-controlling device comprising toggle-levers, lifting-links actuated thereby, hook-pieces controlled by the supplemental pattern-chain, and connected to the toggle-levers, pivoted pieces having actuating blades or sweeps connected to move toward and away from each other, a spring for normally separating the actuating-blades, and a cam for moving the actuating-blades toward each other, substantially as described.

2. In a device of the class described, the combination of toggle-levers, lifting-links actuated thereby, stops for said toggle-levers, one of said stops being arranged so that the toggle-levers can slightly pass their center of motion to lock a lifting-link in its raised position, hook-pieces connected to the toggle-levers, a pivoted bell-crank lever having an actuating blade or sweep, and a friction-roll, a cam driven from the operating parts of the loom to engage said friction-roll, a pivoted lever having a second actuating blade or sweep, a pin-and-slot connection for causing the actuating-blades to move toward each other, and a spring for normally separating said actuating-blades, substantially as described.

In testimony whereof I have hereunto set my hand in the presence of two subscribing witnesses.

JOHN F. DUSTIN.

Witnesses:

LOUIS W. SOUTHGATE,
PHILIP W. SOUTHGATE.