

**(12) STANDARD PATENT**  
**(19) AUSTRALIAN PATENT OFFICE**

(11) Application No. **AU 2017370751 B2**

(54) Title  
**Improved methods for multiplex imaging using labeled nucleic acid imaging agents**

(51) International Patent Classification(s)  
**C12Q 1/68** (2018.01)                      **C12Q 1/6818** (2018.01)  
**C12Q 1/6804** (2018.01)                  **C12Q 1/6823** (2018.01)  
**C12Q 1/6806** (2018.01)

(21) Application No: **2017370751**                      (22) Date of Filing: **2017.12.08**

(87) WIPO No: **WO18/107054**

(30) Priority Data

(31) Number	(32) Date	(33) Country
<b>62/432,511</b>	<b>2016.12.09</b>	<b>US</b>
<b>62/445,896</b>	<b>2017.01.13</b>	<b>US</b>

(43) Publication Date: **2018.06.14**

(44) Accepted Journal Date: **2023.11.09**

(71) Applicant(s)  
**Ultivue, Inc.**

(72) Inventor(s)  
**Hennek, Stephanie Rae;Manesse, Mael;Chen, Xi;Natan, Michael Jules;Mohammed, Abdul**

(74) Agent / Attorney  
**Pizzeys Patent and Trade Mark Attorneys Pty Ltd, GPO Box 1374, Brisbane, QLD, 4001, AU**

(56) Related Art  
**US 2016/0289750 A1**  
**US 2015/0267251 A1**



(51) International Patent Classification:

C12Q 1/68 (2018.01) C12Q 1/6818 (2018.01)  
C12Q 1/6804 (2018.01) C12Q 1/6823 (2018.01)  
C12Q 1/6806 (2018.01)

(21) International Application Number:

PCT/US2017/065362

(22) International Filing Date:

08 December 2017 (08.12.2017)

(25) Filing Language:

English

(26) Publication Language:

English

(30) Priority Data:

62/432,511 09 December 2016 (09.12.2016) US  
62/445,896 13 January 2017 (13.01.2017) US

(71) Applicant: **ULTIVUE, INC.** [US/US]; 763D Concord Avenue, Cambridge, Massachusetts 02138 (US).

(72) Inventor; and

(71) Applicant: **MOHAMMED, Abdul** [IN/US]; 763D Concord Avenue, Cambridge, Massachusetts 02138 (US).

(72) Inventors: **WALTER, Stephanie Rae**; 763D Concord Avenue, Cambridge, Massachusetts 02138 (US). **MANESSE, Mael**; 763D Concord Avenue, Cambridge, Massachusetts 02138 (US). **CHEN, Xi**; 31 Kerry Court, West Newton, Massachusetts 02465 (US). **NATAN, Michael Jules**; 763D Concord Avenue, Cambridge, Massachusetts 02138 (US).

(74) Agent: **MCNEILL, Rebecca** et al.; 125 Cambridge Park Drive, Suite 301, Cambridge, Massachusetts 02140 (US).

(81) Designated States (unless otherwise indicated, for every kind of national protection available): AE, AG, AL, AM,

AO, AT, AU, AZ, BA, BB, BG, BH, BN, BR, BW, BY, BZ, CA, CH, CL, CN, CO, CR, CU, CZ, DE, DJ, DK, DM, DO, DZ, EC, EE, EG, ES, FI, GB, GD, GE, GH, GM, GT, HN, HR, HU, ID, IL, IN, IR, IS, JO, JP, KE, KG, KH, KN, KP, KR, KW, KZ, LA, LC, LK, LR, LS, LU, LY, MA, MD, ME, MG, MK, MN, MW, MX, MY, MZ, NA, NG, NI, NO, NZ, OM, PA, PE, PG, PH, PL, PT, QA, RO, RS, RU, RW, SA, SC, SD, SE, SG, SK, SL, SM, ST, SV, SY, TH, TJ, TM, TN, TR, TT, TZ, UA, UG, US, UZ, VC, VN, ZA, ZM, ZW.

(84) Designated States (unless otherwise indicated, for every kind of regional protection available): ARIPO (BW, GH, GM, KE, LR, LS, MW, MZ, NA, RW, SD, SL, ST, SZ, TZ, UG, ZM, ZW), Eurasian (AM, AZ, BY, KG, KZ, RU, TJ, TM), European (AL, AT, BE, BG, CH, CY, CZ, DE, DK, EE, ES, FI, FR, GB, GR, HR, HU, IE, IS, IT, LT, LU, LV, MC, MK, MT, NL, NO, PL, PT, RO, RS, SE, SI, SK, SM, TR), OAPI (BF, BJ, CF, CG, CI, CM, GA, GN, GQ, GW, KM, ML, MR, NE, SN, TD, TG).

Published:

— with international search report (Art. 21(3))

(54) Title: IMPROVED METHODS FOR MULTIPLEX IMAGING USING LABELED NUCLEIC ACID IMAGING AGENTS

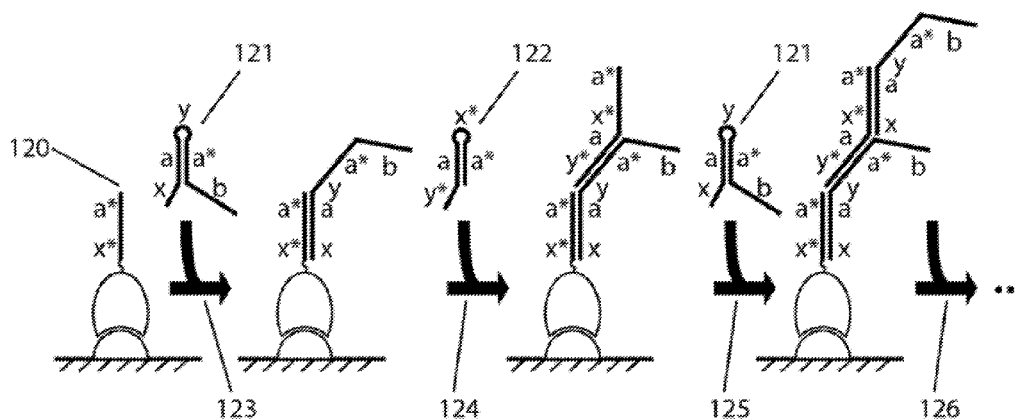

FIG. 1D

(57) Abstract: The present application provides certain advantageous ways of conducting multiplexed imaging.

WO 2018/107054 A1

# IMPROVED METHODS FOR MULTIPLEX IMAGING USING LABELED NUCLEIC ACID IMAGING AGENTS

## DESCRIPTION

### FIELD

[001] This application relates generally to the field of detection and quantification of analytes (*e.g.*, targets).

### BACKGROUND

[002] Fluorescence microscopy is a powerful tool for exploring molecules in, for example, a biological system. However, the number of distinct species that can be distinguishably and simultaneously visualized (*i.e.* the multiplexing power) is limited by the spectral overlap between the fluorophores. Some multiplexed imaging methods are known, but may not adequately produce a strong enough signal or may require specific means of switching between targets being imaged. Thus, there is a need for new and improved multiplexed imaging methods employing improved amplification methods and additional means of switching between targets being imaged.

### SUMMARY

[003] In accordance with the description, in some embodiments, a method to test a sample for the presence of one or more targets comprises:

- (1) contacting a sample being tested for the presence of one or more targets with one or more target-specific binding partners, wherein each target-specific binding partner is linked to a nucleic acid strand and wherein target-specific binding partners of different specificity are linked to different nucleic acid strands,
- (2) optionally removing unbound target-specific binding partners,
- (3) contacting the sample with a nonlinear amplifier strand having complementarity to a nucleic acid strand, wherein the nucleic acid strand is either a docking strand or a primer strand,

- (4) optionally removing unbound nonlinear amplifier strands,
- (5) in either one or two steps amplifying the docking strand with rolling circle amplification and contacting the sample with labeled imager strands having complementarity to the docking strand or amplified strand,
- (6) imaging the sample to detect bound labeled imager strands,
- (7) removing the bound labeled imager strands, and
- (8) optionally repeating steps (1)-(8), or any subset thereof.

[004] In some embodiments, a method to test a sample for the presence of one or more targets comprises:

- (1) contacting the sample with one or more target-specific binding partners, wherein each target-specific binding partner is linked to a nucleic acid strand, directly or indirectly, and wherein target-specific binding partners of different specificity are linked to different nucleic acid strands,
- (2) optionally removing unbound target-specific binding partners,
- (3) wherein the nucleic acid strand is a docking strand or a primer strand and if the nucleic acid is
  - (a) a docking strand, optionally increasing the number of docking strands associated with each target-specific binding partner, or
  - (b) a primer strand, optionally associating more than one docking strand with the primer strand,
- (4) contacting the sample with labeled imager strands capable of binding a docking strand, directly or indirectly,
- (5) optionally removing unbound labeled imager strands,
- (6) imaging the sample to detect bound labeled imager strands, and
- (7) optionally extinguishing signal from the bound labeled imager strand;
- (8) optionally repeating steps (1)-(7) or any subset thereof.

[005] In some embodiment, a composition comprises: a sample bound to more than one target-specific binding partners, each binding partner bound to a nucleic acid strand and at least one docking strand stably bound to a labeled imager

strand, directly or indirectly, wherein the nucleic acid strand is a docking strand or a primer strand if the nucleic acid is

- (a) a docking strand, increasing the number of docking strands associated with each target-specific binding partner, or
- (b) a primer strand, associating more than one docking strand with the primer strand.

[006] In some embodiments, a composition comprises

- (1) a label,
- (2) a first nucleic acid domain, a second nucleic acid domain, and a third nucleic acid domain, wherein each nucleic acid domain is from 1 to 9 nucleotides long,
- (3) a first linking moiety linking the first nucleic acid domain and the second nucleic acid domain and
- (4) a second linking moiety linking the second nucleic acid domain and the third nucleic acid domain,

wherein both linking moieties are independently chosen from (a) an abasic site with an intact phosphodiester backbone, (b) a linker cleavable by a nucleic acid glycosylase, (c) non-natural nucleotides, or (d) restriction site or a nicking site.

[007] Additional objects and advantages will be set forth in part in the description which follows, and in part will be obvious from the description, or may be learned by practice. The objects and advantages will be realized and attained by means of the elements and combinations particularly pointed out in the appended claims.

[008] It is to be understood that both the foregoing general description and the following detailed description are exemplary and explanatory only and are not restrictive of the claims.

[009] The accompanying drawings, which are incorporated in and constitute a part of this specification, illustrate one (several) embodiment(s) and together with the description, explain the principles described herein.

## BRIEF DESCRIPTION OF THE DRAWINGS

[0010] Figures 1A-E show a scheme of attaching Docking Strands to the target via a target-recognizing moiety. Specifically, Figure 1A shows Attachment of the Docking Strand to the target-recognizing moiety without signal amplification. Figure 1B shows attachment of the Docking Strand to the target-recognizing moiety with signal amplification using a branched structure, which can be created using processes such as HCR. Figure 1C shows attachment of the Docking Strand to the target-recognizing moiety with signal amplification using a linear structure, which can be created using processes such as RCA. Figure 1D shows modified hybridization chain reaction (HCR), where a docking site (domain b) is attached to one of the two hairpins of HCR, allowing introduction of multiple docking sites to one target-recognizing moiety. Figure 1E shows rolling circle amplification to introduce multiple docking site (domain c-d) to one target-recognizing moiety. The following reference numbers are used in this figure. 101: Target. 102: Target-recognizing moiety. 103: Docking Strand. 120: Primer strand of the HCR reaction that is attached to the target-recognizing moiety. 121: one hairpin of HCR, which is attached with the docking site. 122: another hairpin of HCR. 123-126: Sequential hairpin assembly reactions. 127: Primer that is attached to the target-recognizing moiety. 128: linear template that can be circularized by ligation. 129: The ligation reaction. 130: Primer extension with DNA polymerase with strand-displacement activity. 131: multiple docking sites.

[0011] Figure 2 shows sequential amplification, polymerization, and dendrimerization for amplified and removable signal.

[0012] Figure 3 shows simultaneous amplification, polymerization, and dendrimerization for amplified and removable signal.

[0013] Figures 4A-B illustrate (A) sequential imaging with sequential amplification from HRP-like enzymes and (B) simultaneous imaging with sequential amplification from HRP-like enzymes.

[0014] Figures 5A-D show removal of Imager Strand using nucleic acid-degrading enzymes. (A) General scheme. (B) Embodiments where there is a single deoxyuridine (dU) nucleotide in the Docking Strand-recognizing portion of the Imager Strand. (C) Embodiments where there are multiple dU nucleotides in the Docking Strand-recognizing portion of the Imager Strand. (D) Embodiments where the dU nucleotide is placed within the linkage between the Docking Strand-recognizing portion and the signal-generating moiety of the Imager Strand. 104: imager strand. 105: signal generating moiety of the imager strand. 106: linkage between the target-recognizing moiety and the docking strand. 107: optional linkage to additional docking strands. 120: primer strand of the hybridization chain reaction (HCR) that is attached. 201: dU as an example of a moiety that can be degraded enzymatically. 202: The enzymatic reaction to degrade dU. 203: The process where the remnant of the degradation reaction spontaneously dissociates from the Docking Strand.

[0015] Figures 6A-F shows removal of Imager Strand using polymerase enzymes. (A) A self-priming hairpin is placed at the 3' end of the Imager Strand; the Imager Strand is removed using a polymerase with strand-displacement activity (e.g., phi29). (B) A self-priming hairpin is placed at the 3' end of the Imager Strand which is linked to the signal-generating moiety via nucleic acid hybridization; the Imager Strand is removed using a polymerase with strand-displacement activity. (C) A self-priming hairpin is placed at the 3' end of the Docking Strand; the Imager Strand is removed using a polymerase with strand-displacement activity. (D) A self-priming hairpin is placed at the 3' end of the Imager Strand; the Imager Strand is removed using a polymerase with 5'-to-3' exonuclease activity (e.g., DNA Polymerase I). (E) A self-priming hairpin is placed at the 3' end of the Docking Strand; the Imager Strand is removed using a polymerase with 5'-to-3' exonuclease activity. (F) The self-priming hairpin is replaced by a hybridized duplex with an extendable 3' end. 301: Self-priming hairpin. 302: The reaction where the self-priming hairpin or the hybridized duplex with an extendable 3' end is extended by the DNA polymerase with strand-

displacement activity. 303: The short oligonucleotide that brings the signal-generating moiety to the Imager Strand via hybridization. 304: The reaction where the self-priming hairpin or the hybridized duplex with an extendable 3' end is extended by the DNA polymerase with 5'-to-3' exonuclease activity. 305: hybridized duplex with an extendable 3' end. 306: Linkage between the target-recognizing moiety and the Docking Strand, wherein the linkage comprises covalent or non-covalent interactions.

[0016] Figures 7A-G provide images after amplification. Figure 7A provides a schematic illustrating the process of switching between fluorescence imaging and brightfield imaging with DNA exchange and HRP-based amplification. Figure 7B provides the resulting fluorescence image of tonsil tissue cytokeratin labeled with antibody-DNA conjugate and corresponding fluorescently labeled imager strand. Figure 7C provides resulting brightfield immunohistochemistry image of cytokeratin in the same tonsil tissue following DNA exchange and HRP-based chromogenic amplification. Figures 7D and E show fluorescence signal obtained from cell samples stained for vimentin and DAPI without amplification (D, left) and with rolling circle amplification (E, right). Figure 7F provides resulting fluorescence image of tonsil tissue cytokeratin labeled with antibody-DNA conjugate and corresponding fluorescently labeled imager strand (F, left). Figure 7G, right, shows fluorescence image from the same tissue section after HCR amplification of the docking strands, and hybridization of the corresponding fluorescently labeled imager strand. In Figure 7D and 7E, the images show a DAPI nuclear stain in blue and appears as a generally round or bean-shaped object typically located in the center region of a cell. DAPI stains the DNA inside the nucleus of the cell, and was included in the images as proof that there are cells present in the field of view. The vimentin staining (red) in Figure 7D is lower without amplification and in Figure 7E brighter and more intense with amplification. The red vimentin staining shows filament-like or wispy staining mainly outside of the cell nucleus.

[0017] Figure 8 shows the use of pre-formed nonlinear DNA strands that can be hybridized to docking strands as a starting point for rolling circle polymerization.

[0018] Figures 9A-F and 9H-K show a series of images obtained in the Cy5 channel during an exchange imaging experiment to reinterrogate a target in a sample. Figure 9G shows the average signal intensity in the images of Figures 9A-F.

[0019] Figures 10A-B shows schematics and results for proximity detection with stable binding. Like Figures 7D-7E, Figures 10A-B show DAPI (blue) staining of the nucleus inside of cells. Figure 10A also shows alpha-tubulin staining (green) primarily outside of the nucleus of the cell.

[0020] Figures 11A-C shows cell staining in an experiment designed to evaluate off-target cross reactivity. These figures also use DAPI staining of the nucleus inside of cells (blue). Alpha-tubulin staining (red) is strongly present in Figure 11A, absent in Figure 11B, and weakly present in Figure 11C.

[0021] Figures 12A-D show that the signal from a target can be almost completely extinguished either using USER or UDG.

[0022] Figures 13A-D show various embodiments of exchange imaging, some using primer and intermediate strands in addition to imager and docking strands. Figure 13A shows DNA-Exchange imaging with the use of an intermediate strand (401) to link an imager strand and a docking strand bound to a target through a target-recognition moiety. Figure 13B illustrates a primer strand (404) used to amplify the number of docking strands associated with a target-binding complex, where the resulting amplified product (403) is attached to multiple docking sites (103) and can be imaged with an imager strand, directly or indirectly through an intermediate strand as shown. Figure 13C shows amplification of the number of docking strands associated with a target using a primer strand to initiate a hybridization chain reaction and imaging with the addition of an imager strand, bound to docking strand through an intermediate strand. Figure 13D shows amplification of the number of docking strands associated with a target using a primer strand as a template for ligation and rolling circle amplification, followed by the addition of an imager strand, bound to docking strands through intermediate strands for imaging.

[0023] Figures 14A-D show removal efficiency of imager strands using nucleic acid-degrading enzymes varies with sequence design. Imager strands were synthesized with (Figure 14B and D) and without (Figure 14A and C) an abasic site. Fluorescence images of CD3 in tonsil tissues labeled with antibody-DNA conjugates are shown before (Figures 14A-B, shown at a 30,000-intensity scale) and after (Figures 14C-D, shown at a 2,000-intensity scale) removal of the corresponding fluorescently labeled imager strands.

[0024] Figures 15A-F show an embodiment of exchange imaging in which four targets are imaged using four imager strands labeled with two different fluorophores, two targets at a time, sequentially. Thus, Figure 15 shows a combination of spectral and sequential multiplexing.

[0025] The following reference numbers are used throughout the figures and the application:

<b>Table 1: Figure Reference Numbers</b>	
101	target
102	target-recognizing moiety
103	docking strand
104	imager strand
105	signal generating moiety of the imager strand
106	linkage between the target-recognizing moiety and the docking strand
107	optional linkage to additional docking strands
120	primer strand of the hybridization chain reaction (HCR) that is attached to the target-recognizing moiety
121	one hairpin of HCR, which is attached with the docking site
122	another hairpin of HCR
123- 126	sequential hairpin assembly reactions
127	primer that is attached to the target-recognizing moiety
128	linear template that can be circularized by ligation

129	the ligation reaction
130	primer extension with DNA polymerase with strand-displacement activity
131	multiple docking sites
201	dU as an example of a moiety that can be degraded enzymatically
202	the enzymatic reaction to degrade dU
203	the process where the remnant of the degradation reaction spontaneously dissociates from the docking strand
301	self-priming hairpin
302	the reaction where the self-priming hairpin or the hybridized duplex with an extendable 3' end is extended by the DNA polymerase with strand-displacement activity
303	the short oligonucleotide that brings the signal-generating moiety to the Imager Strand via hybridization
304	the reaction where the self-priming hairpin or the hybridized duplex with an extendable 3' end is extended by the DNA polymerase with 5'-to-3' exonuclease activity
305	hybridized duplex with an extendable 3' end
306	linkage between the target-recognizing moiety and the docking strand, wherein the linkage comprises covalent or non-covalent interactions
401	intermediate strand
402	amplification reaction
403	amplification product and associated docking strands
404	primer

## DESCRIPTION OF THE EMBODIMENTS

### I. Methods of Testing a Sample for the Presence of One or More Targets

[0026] This application relates to improved methods and compositions for testing for the presence of one or more targets with one or more target specific binding partners.

[0027] Exchange Imaging is a method to achieve high multiplexing capability so that many targets can be imaged on the same sample. The central concept of Exchange Imaging involves the following steps: (1) attaching different decodable information-carrying molecules (called docking strands) to different target-specific binding partners (such as but not limited to an antibody that recognizes a target), wherein target-specific binding partners of different specificity (i.e., binding different targets) are linked to different docking strands and optionally removing unbound target-specific binding partners (2) using a set of molecules (called imager strands), each specifically recognizing a docking strand and carrying an observable moiety, to label *a subset* of docking strands, and imaging the corresponding subset of targets, (3) extinguishing the signal from the bound labeled imager strand by removing the set of imager strands used in step 2, removing the observable moiety from the imager strand, or inactivating the observable moieties on such imager strands, and (4) using another set of imager strands, each specifically recognizing a docking strand and carrying an observable moiety, to label *another subset* of docking strands, and imaging the corresponding subset of targets, (5) optionally, steps 3 and 4 can be repeated to visualize multiple subsets of targets. End users will readily appreciate that not all steps should be repeated in all experiments. For example, in the last round of imaging, there would be no need to extinguish the signal from the bound labeled imager strand because no further imaging strands would be applied.

[0028] One non-limiting example of Exchange Imaging is DNA Exchange Immunofluorescence, where one uses antibodies as the target-recognizing molecules to image target proteins or other biomolecules, uses DNA oligonucleotides as docking strands, and uses DNA oligonucleotides that are complementary to the docking strands and labeled with at least one observable moiety (such as a fluorophore) as the imager strands. In step 3, extinguishing the signal from the bound labeled imager strand includes several embodiments. In some embodiments, one may remove the imager strand, remove the label from the imager strand, and/or the inactivate the label attached to the imager strand. These various methods may be

employed by using high temperature, low ionic strength buffers, denaturant (including formamide, for example), DNA helicase, DNase, strand displacement, chemical cleavage, enzymatic cleavage, chemical bleaching, photo-bleaching, and/or photochemical bleaching. By bound labeled imager strand, we aim to distinguish the labeled imager strand that has, at one point, bound to the docking strand from the excess labeled imager strand that did not bind to a docking strand. During the process of extinguishing the signal, the so-called bound labeled imager strand may remain bound to the docking strand or it may not remain bound to the docking strand.

[0029] In some embodiments, imaging the sample to detect bound labeled imager strands detects the presence of bound labeled imager strands. In some embodiments, imaging the sample to detect bound labeled imager strands detects the presence, location, and/or number of bound labeled imager strands.

[0030] Various types of imaging may be used in conjunction with the methods. For example, the imaging may include any type of microscopy that has an objective, illumination, and a sensor. In some embodiments, imaging is performed using a light microscope, fluorescence microscope including widefield, confocal (line and point scanning, spinning disk), total internal reflection (TIR), stimulated emission depletion (STED), light-sheet illumination (including lattice light-sheet illumination), structured illumination (SIM), expansion microscopy, and electron microscopy.

#### **A. Amplification Methods**

[0031] In microscopy, signal amplification is desired in many situations such as when the abundance of target is low, when the allowable exposure time is short, and/or when the sensitivity of the imaging equipment is low. Signal amplification offers advantages in DNA exchange immunofluorescence. In traditional, single-plex immunofluorescence (where only one target is analyzed), one often uses unconjugated primary antibody and fluorescent-labeled secondary antibody. Because the secondary antibodies are often polyclonal, multiple molecules of secondary antibody can bind to one molecule of primary antibody, resulting in amplification of

signal. In DNA Exchange Immunofluorescence, however, in some embodiments, users directly label the DNA docking strand to the primary antibody, thus eliminating such signal-amplification step obtained by using a polyclonal secondary antibody. As a result, in some cases, DNA exchange immunofluorescence may have lower signal intensity relative to traditional immunofluorescence.

[0032] Thus, in one embodiment, amplification is used to improve the signal intensity in multiplexed DNA exchange immunofluorescence. Many methods for signal amplification in microscopy exist, but not all can be applied to DNA exchange immunofluorescence. One of the most well-known methods involves linking (covalently or non-covalently) the target-recognizing molecule (e.g., antibody) to an enzyme that can convert a non-observable substrate into an observable product. Many enzymes such as horseradish peroxidase (HRP), alkaline phosphatase (AP), glucose oxidase (GO),  $\beta$ -galactosidase ( $\beta$ -gal) have been used for these purposes. And an array of chromogenic, fluorogenic and chemiluminescent substrates for these enzymes have been developed, such as 3,3'-diaminobenzidine (DAB), nitro blue tetrazolium chloride (NBT), 5-bromo-4-chloro-3-indolyl phosphate (BCIP), and 5-bromo-4-chloro-3-indoyl- $\beta$ -D-galactopyranoside (X-Gal). Another strategy to exploit such enzymes in signal amplification is to create covalent bonds between the target (or other molecules in vicinity to the target) and an observable reporter molecule. This strategy is exemplified by tyramide signal amplification (TSA) technology that is commercialized by Thermo Fisher and Perkin Elmer, among others. However, none of these signal-amplification methods is compatible with exchange imaging, as the observable reporter, enzyme/primer or the substrate is brought to the vicinity of the target permanently or without a decodable docking strand. DNA-based (i.e., decodable) signal amplification methods where the observable signal can, at least in principle, be removed have been reported (e.g., Zimak, et al., *Chembiochem* 13(18):2722-8 (2012) (PMID: 23165916)). However, such methods involve multiple rounds of manipulation and the signal gain is modest.

[0033] Another type of signal amplification involves linking (covalently or non-covalently) the target-recognizing molecule to a primer molecule of a polymerization or dendrimerization reaction. One example of such polymerization reactions is rolling circle amplification (RCA) where the primer of the RCA is linked to the target-recognizing molecule and is converted to a long repetitive single-stranded DNA. Fluorescent molecules can be either directly incorporated into the RCA product via fluorescent-labeled nucleotides, or be bound to the RCA product as a part of a fluorescent-labeled oligonucleotide that is designed to hybridize to the RCA product. Other examples of such polymerization or dendrimerization reactions include branched DNA toehold-based strand displacement (Schweller et al. PMID: PMC3517005), hybridization chain reaction (HCR) (Dirks et al., 2014, PMID: 15492210, 24712299) and a similar DNA hairpin-based dendrimerization reaction (Yin et al., 2008, PMID 18202654), which here we call HDR. Common applications of amplification methods such as RCA, HCR, and HDR do not include the option for Exchange Imaging, but could be compatible as demonstrated by the improvements described herein.

[0034] Herein we discuss embodiments covering signal amplification that is compatible with exchange imaging. We describe a series of embodiments that make signal amplification compatible with exchange imaging. These embodiments can be divided into two classes based on whether the amplification product is decodable. For example, if the amplification product contains a docking strand component (e.g. single-stranded DNA), many (e.g., >5) antibodies against different targets can be programmed to generate such product of distinct docking strand sequences that can later be decoded by the ssDNA molecules of complementary sequence. Thus, such amplification product is considered decodable. In such cases, signal amplification for different targets can be carried out simultaneously, followed by simultaneous and/or sequential imaging of different amplification products. Simultaneous amplification carried out for different targets can be considered multiplexed amplification.

[0035] In contrast, when the amplification product is a fluorophore or label that is covalently attached or noncovalently deposited near the target but does not contain a docking strand that could interact with an imager strand, these amplification products are considered undecodable. For example, when the enzyme responsible for signal amplification is HRP, the product is a chemical chromophore that does not allow many variations that can be specifically bound by many molecules serving as imager strands. In such cases, signal amplification for different targets may be carried out sequentially, and the enzyme linked to a target that has already been amplified may be removed from the sample. Simultaneous signal amplification of undecodable amplification products is possible if orthogonal enzyme-substrate pairs can be used.

[0036] Therefore, in some embodiments a method comprises (1) contacting a sample being tested for the presence of one or more targets with one or more target-specific binding partners, wherein each target-specific binding partner is linked to a nucleic acid strand, and wherein target-specific binding partners of different specificity are linked to different nucleic acid strands, (2) optionally removing unbound target-specific binding partners, (3) wherein the nucleic acid strand is a docking strand or a primer strand and if the nucleic acid is (a) a docking strand, increasing the number of docking strands associated with each target-specific binding partner or (b) a primer strand, associating more than one docking strand with the primer strand (in either (a) or (b), such as, for example, amplifying the number of docking strands available), (4) contacting the sample with labeled imager strands capable of binding a docking strand, directly or indirectly, (5) optionally removing unbound labeled imager strands, (6) imaging the sample to detect bound labeled imager strands, (7) optionally removing the bound labeled imager strands from the docking strands, and (8) optionally repeating steps (1)-(6), or any subset thereof.

[0037] By docking strands associated each target specific binding partner, here and throughout the application, Applicant does not intend to require amplification to occur on every single docking strand, but that amplification generally occurs on the docking strands associated with the various target-specific binding partners, as

desired by the user (including amplifying only some docking strands participating in detecting targets A and B, while not amplifying docking strands participating in detecting target B.) Amplification may also be incomplete, such as amplification occurring on only some but not all of the copies of the docking strand participating in detecting a given target. Additionally, amplification may replicate the entire docking strand or it may replicate only a portion of the docking strand sufficient for binding an imager strand.

[0038] Additionally, in some embodiments, a method comprises (1) contacting a sample being tested for the presence of one or more targets with one or more target-specific binding partners, wherein each target-specific binding partner is linked to a nucleic acid strand and wherein target-specific binding partners of different specificity are linked to different nucleic acid strands, (2) optionally removing unbound target-specific binding partners, (3) contacting the sample with labeled imager strands capable of binding a docking strand, directly or indirectly, wherein the nucleic acid strand in (1) is either a primer strand or a docking strand and if the nucleic acid strand is a primer strand, it is linked to a docking strand (4) optionally removing unbound labeled imager strands, (5) imaging the sample to detect bound labeled imager strands and determine if amplification (step (7)) is required, (6) optionally removing the bound labeled imager strands from the docking strands, (7) optionally increasing the number of docking strands associated with each target-specific binding partner (such as, for example, amplifying the number of docking strands available by multiple means, including, but not limited to self-assembly of docking strand complexes, other assembly methods, branched and circular docking strands, etc.), and (8) optionally repeating steps (1)-(7), or any subset thereof.

### **1. Amplification**

[0039] **Decodable amplification products.** Decodable amplification products include those cases in which the amplified product is a docking strand. In one embodiment, the docking strand does not contain an observable label. In one embodiment, the docking strand serves as a barcode for an observable label (or

imager strand). It should be noted at the outset that the docking strands, or docking sites, may be introduced to the target during a signal-amplification reaction (**Fig. 1b-c**), so that multiple docking strands are attached to one target molecule. Without being limiting, there are at least two strategies of achieving this: (Strategy 1) creating multiple docking sites that are attached to a scaffold, which is in turn attached to the target-recognizing moiety (**Fig. 1b**), and (Strategy 2) creating multiple binding sites on one piece of long single-stranded DNA that is attached to the target-recognizing moiety (**Fig. 1c**).

[0040] One may use RCA, HCR or HDR to generate a polymeric or dendrimeric product from the primer molecule linked to the antibody. In some embodiments, the product may contain many (e.g., greater than 2, 5, 10, 15, 20, 25, 50, 100, etc.) copies of single-stranded DNA domains that can serve as the docking strand and thus be recognized by oligonucleotides serving as the imager strand. Such DNA domains may be long enough (e.g. 7, 8, 9, 10, 11, 12, 13, 14, 15, 20, or more nucleotides long, or be able to bind its complementary strand with  $K_d < 1$  nM at imaging condition). For RCA, this is achieved regularly. For HCR and HDR, if necessary one can include, at the loop or tail of the substrate hairpin, DNA domains that do not participate in the strand-displacement cascades but constitute part or the entirety of the imager strand-binding site.

[0041] In one embodiment, a modified version of hybridization chain reaction (HCR) is employed for signal amplification, in which two hairpins (105 and 106 of **Fig. 1d**) are assembled onto the primer strand (104 of **Fig. 1d**) in an alternating fashion. Either or both of the two hairpins can carry a docking site (domain b on hairpin 105 of **Fig. 1d**). Tens to hundreds of hairpin units can be assembled onto one primer strand, bringing tens to hundreds of docking sites to the target-recognizing moiety. Several pairs of hairpin sequences (without the docking site) have been demonstrated by the Pierce group to enable successful HCR reactions. Hairpin sequences with the docking sites can be designed with the same principle, although

care may be taken to ensure that the docking site does not form unwanted secondary structure with the rest of the hairpin.

[0042] In another embodiment, signal amplification involves linking (covalently or non-covalently) the target-recognizing molecule to a primer molecule of a polymerization or dendrimerization reaction. One example of such polymerization reactions is rolling circle amplification (RCA, **Fig. 1e**) where the primer of the RCA is linked to the target-recognizing molecule and is converted to a long repetitive single-stranded DNA. Fluorescent molecules can be either directly incorporated into the RCA product via fluorescent-labeled nucleotides, or be bound to the RCA product as a part of a fluorescent-labeled oligonucleotide that is designed to hybridize to the RCA product.

[0043] There are many ways to carry out RCA, one of which is to first ensure that the oligonucleotide conjugated to the target-recognizing moiety (here we call 'primer', 111 of **Fig. 1e**) has an extendable 3' end. Then one can introduce a linear template strand (112 of **Fig. 1e**) that can hybridize to the primer in the circular fashion, in which the primer brings the two ends of the template together so that the two ends can be ligated. Next, a ligase (such as T4 DNA ligase or CircLigase™ ssLigase, for example) is used to ligate the two ends to form a circle. After the ligation the primer is hybridized to the circular template. Next, a DNA polymerase with strand-displacement activity (e.g., phi29, Bst, Vent(exo<sup>-</sup>)) can extend the primer along the circular template multiple rounds to create a concatemeric repeat. Part of the entirety of the repeat unit (domains c-d, or 115 of **Fig. 1e**) can serve as the docking sites (or docking strands) for imager strands.

[0044] An alternative method of RCA involves the use of a nonlinear amplifier or template strand, wherein an oligonucleotide (such as a docking strand) conjugated to the target-recognizing moiety is hybridized to a circular DNA template (amplifier strand), followed by extension of the docking strand by a DNA polymerase to create a concatemeric repeat of the reverse complement of the amplifier strand (i.e. an amplified strand or RCA product). The hybridization of the amplifier strand to the

oligonucleotide conjugated target-recognizing moiety may occur before (preassembly or prehybridization) or after the oligonucleotide conjugated target-recognizing moiety contacts the sample.

[0045] Thus, in some embodiments, at least one oligonucleotide-conjugated target-recognizing moiety is hybridized to a nonlinear amplifier strand before being introduced to the sample. When the user chooses to pre-assemble an antibody-DNA conjugate with an amplifier, a method to test a sample for the presence of one or more targets comprises (1) contacting a sample being tested for the presence of one or more targets with one or more target-specific binding partners, wherein each target-specific binding partner is linked to a nucleic acid strand and wherein target-specific binding partners of different specificity are linked to different nucleic acid strands, and wherein at least one nucleic acid strand is hybridized to a nonlinear amplifier strand (2) optionally removing unbound target-specific binding partners, (3) amplifying the docking strand with rolling circle amplification (i.e., increasing the number of docking strands or introducing a plurality of docking strands) to produce a rolling circle amplification product (4) contacting the sample with labeled imager strands having complementarity to the docking strand or the rolling circle amplification product, (5) imaging the sample to detect bound labeled imager strands, (6) optionally removing the bound labeled imager strands, and (7) optionally repeating steps (1)-(7), or any subset thereof. In this process, the rolling circle amplification product comprises a concatemeric repeat of the reverse complement of the amplifier strand.

[0046] In another embodiment, imager strands may be hybridized to the RCA product (e.g. the concatemeric repeat of the reverse complement of the amplifier strand that is linked to the target-recognizing moiety) during the RCA reaction. In some embodiments, therefore, amplification occurs using rolling circle amplification, while in the presence of labeled imager strands having complementarity to the amplified strand. For example, a sample may be contacted with an oligonucleotide conjugated to a target-recognizing moiety that is either prehybridized to an amplifier

strand or the amplifier strand may be hybridized in a later step. Then, all additional components for the RCA reaction may be added in one step including proteins (e.g. DNA polymerases, optionally BSA), nucleotides, buffer solution, salts, and imager strands. In some embodiments, a user may wish to prevent the imager strand from being amplified. This can be accomplished by several means, including, but not limited to employing a 3'-modified imager strand having a modification on the 3' end. For example, the 3' modification on the imager strand may include a label (such as a fluorophore), a modified base, a stop code or terminator, a 3'-O-modification, a dideoxy-C, a dideoxy-G, a dideoxy-A, a dideoxy-T, an inverted nucleotide, any modification that eliminates the presence of a 3' hydroxyl group, or a single-stranded extension of the 3' end that is not complementary to the amplifier strand.

[0047] In addition to HCR and RCA, other examples of such polymerization or dendrimerization reactions include DNA hairpin-based dendrimerization reaction (HDR) (Yin et al., 2008, PMID 18202654), and toe-hold mediated strand displacement.

[0048] DNA strand displacement is a method for the isothermal and dynamic exchange of DNA complexes. Strand displacement can be designed and intentionally controlled based on an understanding of DNA hybridization interactions and thermodynamics, and can be facilitated by introducing engineered handles which are known as "toehold domains." The ability to modulate binding interactions and exchange hybridization partners gives rise to a series of potential signal amplification applications.

[0049] In another embodiment, an encodable tyramide-based signal amplification product is described. This method comprises (1) contacting a sample being tested for the presence of one or more targets with one or more target-specific binding partners, wherein each target-specific binding partner is linked to a nucleic acid strand and wherein target-specific binding partners of different specificity are linked to different nucleic acid strands, (2) optionally removing unbound target-specific binding partners, (3) contacting the sample with enzyme-labeled strands

capable of binding a docking strand, wherein the nucleic acid strand in (1) is either a primer strand or a docking strand and if the nucleic acid strand is a primer strand, it is linked to a docking strand (5) optionally removing unbound enzyme-labeled strands, (4) contacting the sample with tyramide-bound docking strands, (5) enzymatically converting the tyramide moiety into an activated state, wherein the activated state results in a covalent linkage of the tyramide-bound docking strand to the enzyme-labeled target site, (6) optionally quenching the enzymatic reaction, (7) removing the enzyme-labeled strands, and (8) optionally repeating a subset of steps 3-8. In one embodiment, the enzyme-linked strand is an HRP-linked strand.

[0050] In another embodiment, a method comprises (1) contacting a sample being tested for the presence of one or more targets with one target-specific binding partner, wherein the target-specific binding partner is linked to an enzyme (2) optionally removing unbound target-specific binding partners, (3) contacting the sample with tyramide-bound docking strands, (4) enzymatically converting the tyramide moiety into an activated state, wherein the activated state results in a covalent linkage of the tyramide-bound docking strand to the enzyme-labeled target site, (5) quenching the enzymatic reaction, and (6) optionally repeating a subset of steps 1-8, wherein target-specific binding partners of different specificity are introduced. In one embodiment, the enzyme-linked target-specific binding partners contain HRP.

[0051] As shown in **Figure 2**, the amplification of multiple targets can be carried out sequentially. Alternatively, the amplification of multiple targets can be carried out simultaneously (**Figure 3**). Imaging steps can be carried out between rounds of amplification, or following all rounds of amplification.

[0052] **Undecodable amplification products.** Undecodable amplification products include those cases in which the amplified product is an observable label that does not have specific affinity for an imager strand. In one embodiment, the undecodable amplification product could be a fluorophore, chromogenic stain, or nanoparticle.

[0053] In one embodiment, a method to produce undecodable amplification products comprises: (1) contacting a sample being tested for the presence of one or more targets with one or more target-specific binding partners, wherein each target-specific binding partner is linked to a nucleic acid strand and wherein target-specific binding partners of different specificity are linked to different nucleic acid strands, (2) optionally removing unbound target-specific binding partners, (3) contacting the sample with enzyme-labeled strands capable of binding a docking strand, wherein the nucleic acid strand in (1) is either a primer strand or a docking strand and if the nucleic acid strand is a primer strand, it is linked to a docking strand, (4) optionally removing unbound enzyme-labeled strands, (5) contacting the sample with a substrate for the enzyme, (6) allowing an enzymatic reaction to produce an amplification product, (7) quenching the enzymatic reaction, (8) imaging the sample to detect the presence or absence of one or more targets, (9) removing the amplification product, and (10) repeating a subset of steps 1-9. Examples of enzymes that could be used include HRP, AP, GO,  $\beta$ -gal. When the enzyme is linked to an imager strand, i.e. a strand capable of binding a docking strand), sequential amplification and imaging can be carried performed (**Fig. 4**). **Figure 4a** illustrates a method for sequential amplification and sequential imaging. Here, a method is employed to remove or inactivate the amplification product between each imaging round. Removing or inactivating the amplification product can be done by carefully choosing the substrate. For example, one may use a chromogenic substrate of HRP that is soluble in sample-friendly organic solution (e.g., 3-amino-9-ethylcarbazole, which is alcohol-soluble, PMID 19365090). In this case, after staining of docking strand-conjugated antibodies (**Fig. 4a**, Step 1), introducing the imager strand-conjugated HRP for one target and the substrate (**Fig. 4**, Step 2), and imaging the sample, one can use alcohol (e.g., methanol) to remove the HRP product and remove the imager strand using any of the method described herein or their combination. Next one can introduce the imager strand-conjugated HRP for another target and repeat the process.

[0054] One may also use the TSA amplification method where the fluorophore can be readily bleached. For example, many cyanine fluorophores and Alexa fluorophore can be readily bleached by hydrogen peroxide in acidic or basic conditions (PMID: 26399630). Alternatively, one can synthesize a TSA dye that contains a cleavable bond between the tyramide and the fluorophore. In this case the fluorophore can be inactivated by cleaving this bond and washing.

[0055] **Figure 4b** illustrates a method for sequential amplification and simultaneous imaging. In this case, after staining of docking strand-conjugated antibodies (**Fig. 4b**, Step 1), introducing the imager strand-conjugated enzyme for one target and the substrate (**Fig. 4**, Step 2, using HRP and TSA for example) to generate amplified product, one can remove the imager strand-conjugated enzyme without removing the amplified product, and repeat multiple rounds of amplification for multiple targets prior to imaging the sample in a single imaging step.

[0056] One may also use RCA, HCR, and HDR to achieve signal amplification without decoding the amplification product. For example, after multiplexed antibody staining, one can add reagent (circular template in the case of RCA, and substrate hairpins in the case of HCR and HDR) that only supports the polymerization/dendrimerization of one subset of target and directly incorporation of fluorescent dyes in the amplification product (e.g., via fluorescent-labeled nucleotides in the case of RCA, and via fluorophore-labeled hairpin substrate in the case of HCR and HDR). After imaging of this subset of targets and inactivation of the dye by bleaching or cleavage as described above, one can introduce the reagent that supports the polymerization/dendrimerization of another subset of targets and directly incorporation of fluorescent dyes in the amplification product. This process can then be repeated.

[0057] Multiple types of signal amplification can even be used in combination. For example, Gusev et al reported combining rolling circle amplification and HRP-based signal amplification (PMID: 11438455).

[0058] One may replace the fluorophore (that is brought to the target via DNA complexes or other amplification method), by other molecule or moieties that can be directly or indirectly observed. These molecules or moieties include, but are not limited to, metal particles, plasmonic enhancers, and proteins.

## 2. Nonlinear Amplification

[0059] A nonlinear DNA template could be employed for signal amplification as a circular amplification strand. A circular oligo, with complementarity to a docking strand, can be generated separately from the amplification method. For example, ex situ ligation could be performed on a template DNA strand to form a circular strand of DNA. A circular strand could be hybridized to a docking strand that is attached to a target-specific binding partner before contacting the sample. Alternatively, the target-specific binding partner could first be used to stain the sample, and then subsequently the circular strand could be introduced to the sample to hybridize with the docking strand on the target-specific binding partner. Following the formation of a complex wherein a circular strand is attached to a docking strand that is linked to a target-specific binding partner, rolling circle amplification (RCA) could be carried out. This method offers certain advantages as it can be used to circumvent issues with inefficient in situ ligation steps.

[0060] In some situations, an amplifier strand may be employed. For example, in some embodiments, a method comprises (1) contacting a sample being tested for the presence of one or more targets with one or more target-specific binding partners, wherein each target-specific binding partner is linked to a nucleic acid strand and wherein target-specific binding partners of different specificity are linked to different nucleic acid strands, (2) optionally removing unbound target-specific binding partners, (3) contacting the sample with a nonlinear amplifier strand having complementarity to a nucleic acid strand, wherein the nucleic acid strand in (1) is either a primer strand or a docking strand (4) optionally removing unbound nonlinear amplifier strands, (5) amplifying the docking strand with rolling circle amplification (i.e., increasing the number of docking strands or introducing a plurality of docking

strands), (6) contacting the sample with labeled imager strands capable of binding a docking strand, either directly or indirectly, (7) imaging the sample to detect bound labeled imager strands, (8) removing the bound labeled imager strands, and (9) optionally repeating steps (1)-(8), or any subset thereof.

[0061] In some embodiments, a polymerase may be used for RCA. In some instances, the labeled imager strands are linear strands. In some instances, the nonlinear amplifier strands are circular strands. In some instances, the nonlinear amplifier strands are branched strands. In some instances, the nonlinear amplifier strand becomes circular after ligation.

[0062] In some embodiments, amplification products may comprise a geometric shape, such as a triangle, quadrilateral, pentagon, hexagon, and the like.

## **B. Variations in Method Steps**

[0063] There are various ways of approaching multiplexed imaging, including options for amplifying the signal using amplification steps at different time points and repeated steps to allow for imaging of multiple targets or reinterrogation of a single target. Methods may also optionally include extinguishing the signaling image at various points in time.

### **1. Amplifying Signal Before Applying Imager Strands and Optionally Extinguishing Signal from the Bound Labeled Imager Strand**

[0064] In some embodiments, a method to test a sample for the presence of one or more targets comprises (1) contacting the sample with one or more target-specific binding partners, wherein each target-specific binding partner is linked to a nucleic acid strand and wherein target-specific binding partners of different specificity are linked to different nucleic acid strands, (2) optionally removing unbound target-specific binding partners, (3) wherein the nucleic acid strand is a docking strand or a primer strand and if the nucleic acid is (a) a docking strand, increasing the number of docking strands associated with each target-specific binding partner or (b) a primer strand, associating more than one docking strand with the primer strand,

(4) contacting the sample with labeled imager strands capable of binding a docking strand, either directly or indirectly, (5) optionally removing unbound labeled imager strands, (6) imaging the sample to detect bound labeled imager strands, and (7) optionally extinguishing signal from the bound labeled imager strand. In some instances, after step (4) and after optionally performing step (5) the method further comprises increasing the number of docking strands associated with each target-specific binding partner. In some embodiments, the method further comprises removing unbound labeled imager strand after the increasing the number of docking strands. Thus, in some modes, amplifying the docking strand with rolling circle amplification occurs separately from contacting the sample with labeled imager strands having complementarity to the amplified strand. By amplified strand, we mean the product of amplification (sometimes also called the amplification product or the RCA product if rolling circle amplification is employed).

[0065] In some instances, the sample is mounted to an optically transparent support. In some embodiments, the increase in the number of docking strands associated with each target-specific binding partner is achieved using an enzyme. For example, the enzyme approaches described in Section I.A above may be employed.

### **1. Amplifying Signal in the Presence of Imager Strands and Optionally Extinguishing Signal from the Bound Labeled Imager Strand**

[0066] In some embodiments, a method to test a sample for the presence of one or more targets comprises (1) contacting the sample with one or more target-specific binding partners, wherein each target-specific binding partner is linked to a nucleic acid strand and wherein target-specific binding partners of different specificity are linked to different nucleic acid strands, (2) optionally removing unbound target-specific binding partners, (3) contacting the sample with labeled imager strands capable of binding a docking strand, either directly or indirectly, (4) wherein the nucleic acid strand is a docking strand or a primer strand and if the nucleic acid is (a) a docking strand, increasing the number of docking strands associated with each

target-specific binding partner or (b) a primer strand, associating more than one docking strand with the primer strand, wherein the amplification occurs in the presence of the imager strand (5) optionally removing unbound labeled imager strands, (6) imaging the sample to detect bound labeled imager strands, and (7) optionally extinguishing signal from the bound labeled imager strand. In some instances, after step (4) and after optionally performing step (5) the method further comprises increasing the number of docking strands associated with each target-specific binding partner. In some embodiments, the method further comprises removing unbound labeled imager strand after the increasing the number of docking strands.

[0067] In some instances, the sample is mounted to an optically transparent support. In some embodiments, the increase in the number of docking strands associated with each target-specific binding partner is achieved using an enzyme. For example, the enzyme approaches described in Section I.A above may be employed.

[0068] The imager strands may have complementarity to the docking strand. The imager strand may be a circular imager strand for rolling circle amplification. The imager strand may be an imager strand that circularizes in the presence of the docking strand and ligase. In some embodiments, the imager strand may comprise at least 2, 3, 4, 5, 6, 7, 8, 9, or 10 regions that are complementary to the docking strand.

## **2. A Method to Test a Sample Mounted to An Optically Transparent Support**

[0069] In some embodiments, a method to test a sample mounted to an optically transparent support for the presence of one or more targets comprises (1) contacting the sample with one or more target-specific binding partners, wherein each target-specific binding partner is linked to a nucleic acid strand and wherein target-specific binding partners of different specificity are linked to different nucleic acid strands, (2) optionally removing unbound target-specific binding partners, (3) wherein the nucleic acid strand is a docking strand or a primer strand and optionally if the nucleic acid is (a) a docking strand, increasing the number of docking

strands associated with each target-specific binding partner or (b) a primer strand, associating more than one docking strand with the primer strand (4) contacting the sample with labeled imager strands capable of binding a docking strand, either directly or indirectly, wherein the labeled imager strands are provided in a liquid medium or buffer solution (5) optionally removing unbound labeled imager strands, (6) optionally removing liquid to create a liquid-free sample, (7) affixing a second optically-transparent material parallel to the first support, and (8) imaging the sample to detect bound labeled imager strands.

[0070] In some embodiments, the second optically-transparent material is glass or plastic. In some instances, the second optically-transparent material is from about 5 microns to 5 mm, from 50 microns to 500 microns, or from 500 microns to 5 mm from the first support. In some instances, the imaging is carried out with an upright microscope.

[0071] In some embodiments, optionally removing liquid to create a liquid-free sample comprises preparing the sample for storage, such as long-term storage for at least 4 hours, 1 day, 3 days, 1 week, 2 weeks, or one month. In some embodiments, optionally removing liquid to create a liquid-free sample increases sample handling convenience because the user does not need to keep the sample hydrated.

[0072] By optionally removing liquid to create a liquid-free sample, this means removing at least about 90%, 91%, 92%, 93%, 94%, 95%, 96%, 97%, 98%, 99%, or 100% of the liquid in a sample (namely, the liquid previously in the sample and associated with the other sample components, such as the sample itself, the docking strand, the imager strand, etc.). In some embodiments, the mounting medium comprises air. In other embodiments, the mounting media comprises a mounting media in a gel formulation. In some embodiments, the mounting media comprises a formula that begins as a liquid but changes to a gel or solid as time elapses (such as a hardening material, glue, cement, or other optically transparent and similarly-functioning material).

[0073] In other embodiments, the liquid in the sample may be replaced by a liquid mounting media such as a saline-based buffered solution (such as PBS).

[0074] Mounting media may be used to hold a specimen in place, to prevent a sample from drying out, to more closely match the refractive index of the objective you will use, to prevent photobleaching (when not desired), and to preserve a sample for long-term storage. The choice of mounting media depends on the sample type, the imaging strategy, which observable moiety is used, and the objectives of the user (whether the user wishes to hydrate the sample or whether the user wishes to store the sample).

[0075] In some embodiments, a method to test a fixed sample mounted to an optically transparent support for the presence of one or more targets comprises (1) contacting the sample with one or more target-specific binding partners, wherein each target-specific binding partner is linked to a nucleic acid strand and wherein target-specific binding partners of different specificity are linked to different nucleic acid strands, (2) optionally removing unbound target-specific binding partners, (3) wherein the nucleic acid strand is a docking strand or a primer strand and if the nucleic acid is (a) a docking strand, increasing the number of docking strands associated with each target-specific binding partner or (b) a primer strand, associating more than one docking strand with the primer strand, (4) contacting the sample with labeled imager strands capable of binding a docking strand, either directly or indirectly, (5) optionally removing unbound labeled imager strands, (6) optionally removing liquid to create a liquid-free sample, (7) affixing a second optically-transparent material parallel to the first support, and (8) imaging the sample to detect bound labeled imager strands.

[0076] In the various multiple embodiments, the optically transparent support and the second optically transparent material parallel to the first support may comprise a flow cell. In the various multiple embodiments, by parallel, it includes geometrical arrangements that are perfectly parallel, as well as those that deviate from parallel by up to 1°, 2°, 3°, 4°, 5°, 6°, 7°, 8°, 9°, or 10°.

### 3. Sample Reinterrogation

[0077] In some embodiments, users may desire to reinterrogate a sample for the same target multiple times. When reinterrogation is desired, the multiplex imaging is conducted by conducting another round of imaging with the same imager stand. Thus, when a user desires to image different targets, the imager strand has a unique nucleotide sequence relative to all other labeled imager strands. When a user desires to image the same target multiple times, the repeated steps use an imager strand that does not have a unique nucleotide sequence relative to all other labeled imager strands, but instead has the same sequence as a previously employed imager strand.

[0078] Thus, in some embodiments, a method comprises (1) contacting a sample being tested for the presence of one or more targets with one or more target-specific binding partners, wherein each target-specific binding partner is linked to a nucleic acid strand and wherein target-specific binding partners of different specificity are linked to different nucleic acid strands, (2) optionally removing unbound target-specific binding partners, (3) wherein the nucleic acid strand is a docking strand or a primer strand and optionally if the nucleic acid is (a) a docking strand, increasing the number of docking strands associated with each target-specific binding partner or (b) a primer strand, associating more than one docking strand with the primer strand, (4) contacting the sample with labeled imager strands capable of binding a docking strand, either directly or indirectly, (5) optionally removing unbound labeled imager strands, (6) imaging the sample to detect presence, location, and number of bound labeled imager strands, (7) extinguishing signal from the bound labeled imager strand, and (8) repeating steps (3)-(6) or (3)-(7), with a labeled imager strand optionally having a unique nucleotide sequence relative to all other labeled imager strands.

### 4. Spectral and Sequential Multiplexing

[0079] Two main methods exist for creating multiplexing in exchange imaging: spectral multiplexing and sequential multiplexing. Spectral multiplexing refers to the ability to use different labels (such as different fluorophores) in a single round of imaging. Spectral multiplexing does not necessitate extinguishing the signal

from the first label before viewing the second label. For example, in the case of fluorophores, different excitation wavelengths of light can be used to individually excite different fluorophores. This does not require separate rounds of imaging. Sequential multiplexing refers to the ability to use the same labels (such as the same fluorophore) in multiple rounds of imaging by extinguishing the signal from the first round of imaging before the second round of imaging. Spectral multiplexing and sequential multiplexing can either be used alone or in conjunction with each other. Using more than one technique of multiplexing, however, can significantly increase the number of targets that a user can visualize during a particular experiment.

[0080] In some embodiments, multiple rounds of imaging are performed with at least some of the same fluorophores. For example, in a first round of imaging, target A can be imaged with label X, target B can be imaged with label Y, and target C can be imaged with label Z. As a next step, the signals from these labels can be extinguished. Then, in a second round of imaging, target D can be imaged with label X, target E can be imaged with label Y, and target F can be imaged with label Z. In some embodiments, at least two targets are imaged using at least two labels, the signal extinguished, and then at least one more target is imaged using at least one of the same labels, wherein the imaging steps may be performed in either order. This means that the order of steps could be reversed so the first imaging step comprises imaging at least one target, the signal extinguished, and the second imaging step comprises imaging at least two targets.

[0081] Combining both spectral multiplexing and sequential multiplexing can increase the overall convenience of performing the imaging for the user and reduce disruption to the sample being imaged.

### **C. Stable Binding**

[0082] In some embodiments, at least some of the complementary agents used in imaging are stably binding to each other and in other embodiments, all the complementary agents used in imaging are stably binding to each other. In some embodiments, the docking strand is stably bound to the imager strand. In some

embodiments, the amplifier strand is stably bound to the docking strand. In some embodiments, the amplifier strand is stably bound to the imager strand.

[0083] In some embodiments, the intermediate strand is stably bound to the docking strand. In some embodiments, the intermediate strand is stably bound the amplifier strand. In some embodiments, the intermediate strand is stably bound the imager strand. In some embodiments, the amplifier strand is stably bound to the imager strand. In some embodiments, the primer strand is stably bound to the docking strand.

[0084] In some embodiments, a composition comprises a sample bound to more than one target-specific binding partners, each binding partner bound to a docking strand, and at least one docking strand stably bound to a labeled imager strand.

[0085] In some embodiments, the stable binding comprises at least the percentage binding for the time recited in Table 2. For example, Table 2 includes 90% binding for at least 30 minutes. This means that of the items bound at  $t=0$ , 90% of the items stay bound for at least 30 minutes. This also means that an equilibrium is achieved that has at least 90% of the docking strand bound to imager strand, for example, at any one time and no more than 10% unbound. The stable binding can include an unbinding of some molecules and a rebinding of other molecules to achieve a population binding percentage; it does not require that at least 90% are permanently bound, it only requires that at any one time at least 90% are bound. Stable binding also can include, wherein V is a variable amount of time corresponding to the length required for the user's experiment and an x means that percentage bound for the length of time qualifies as stable binding:

Table 2: Stable Binding														
Percentage		time (T) bound (at least)												
		minutes								hours			days	
		V	5	10	20	30	40	50	60	3	8	24	48	7
50	x	x	x	x	x	x	x	x	x	x	x	x	x	x

60	x	x	x	x	x	x	x	x	x	x	x	x	x	x
65	x	x	x	x	x	x	x	x	x	x	x	x	x	x
70	x	x	x	x	x	x	x	x	x	x	x	x	x	x
75	x	x	x	x	x	x	x	x	x	x	x	x	x	x
80	x	x	x	x	x	x	x	x	x	x	x	x	x	x
85	x	x	x	x	x	x	x	x	x	x	x	x	x	x
90	x	x	x	x	x	x	x	x	x	x	x	x	x	x
91	x	x	x	x	x	x	x	x	x	x	x	x	x	x
92	x	x	x	x	x	x	x	x	x	x	x	x	x	x
93	x	x	x	x	x	x	x	x	x	x	x	x	x	x
94	x	x	x	x	x	x	x	x	x	x	x	x	x	x
95	x	x	x	x	x	x	x	x	x	x	x	x	x	x
96	x	x	x	x	x	x	x	x	x	x	x	x	x	x
97	x	x	x	x	x	x	x	x	x	x	x	x	x	x
98	x	x	x	x	x	x	x	x	x	x	x	x	x	x
99	x	x	x	x	x	x	x	x	x	x	x	x	x	x
100	x	x	x	x	x	x	x	x	x	x	x	x	x	x

[0086] For example, stably bound may include 70%, 80%, or 90% binding at from about 5 minutes to 7 days, 10 minutes to 60 minutes, 20 minutes to 3 hours, 30 minutes to 24 hours, 3 hours to 24 hours, or 24 hours to 7 days.

[0087] The values in Table 2 apply to all types of stable binding discussed above. Such measurements may be taken at imaging conditions (in some situations room temperature, neutral pH, and physiological buffer conditions), after non-reactive buffer wash(es), or after a non-enzymatic buffer wash(es).

[0088] In some embodiments, the docking strand, primer strand, or intermediate strand engaging in stable binding comprises 30 nucleotides or less, such as from about 8 to 30 nucleotides, from 10 to 25 nucleotides, or from 10 to 20 nucleotides. In some embodiments, the imager strand engaging in stable binding

comprises 30 nucleotides or less, such as from about 8 to 30 nucleotides, from 10 to 25 nucleotides, or from 10 to 20 nucleotides. In some embodiments, the amplifier strand is from about 30 to 60 nucleotides, 20 to 80 nucleotides, 30 to 70 nucleotides, 30 to 60 nucleotides or more than 60 nucleotides. The type of amplification reaction can also impact the length of the amplifier strand desired, with longer lengths desired for hybridization chain reaction (HCR), for example. The person of ordinary skill in the art will recognize that the composition of different bases in the docking strand, imager strand, and/or amplifier strand will impact the number of nucleotides desired in each strand due to affinity differences. Temperature will also impact the number of nucleotides desired.

### **1. Proximity Imaging with Stable Binding**

[0089] In some embodiments, a user may employ proximity imaging with stable binding. In some embodiments, a composition comprises: (a) at least one first binding partner-oligonucleotide conjugate comprising a binding partner linked to an oligonucleotide that comprises a half-docking domain, an optional stability domain, and optionally a spacer domain; (b) at least one second binding partner-oligonucleotide conjugate comprising a binding partner linked to an oligonucleotide that comprises a half-docking domain, an optional stability domain, and optionally a spacer domain; wherein the stability domains of (a) and (b) are complementary to each other, and wherein the half-docking domains of (a) and (b) can combine linearly to form a full docking domain; and (c) at least one labeled imager strand or intermediate strand comprising a 5' domain, a 3' domain, and a linker domain located between the 5' domain and the 3' domain, wherein the 5' domain is complementary to the half-docking domain of (a) and the 3' domain is complementary to the half-docking domain of (b), and wherein the labeled imager strand or intermediate strand capable of being stably bound to the full docking domain and if an intermediate strand is used also providing a labeled imager strand. Alternatively, an intermediate strand may be used and be complementary to both the docking strand and the imager

strand. Amplification may also be employed. The stability criteria set forth in Table 2 also apply in this context.

[0090] In some embodiments, a user may employ proximity imaging with stable binding when employing a primer. In some embodiments, a composition comprises: (a) at least one first binding partner-oligonucleotide conjugate comprising a binding partner linked to an oligonucleotide that comprises a half-primer domain, an optional stability domain, and optionally a spacer domain; (b) at least one second binding partner-oligonucleotide conjugate comprising a binding partner linked to an oligonucleotide that comprises a half-primer domain, an optional stability domain, and optionally a spacer domain; wherein the stability domains of (a) and (b) are complementary to each other, and wherein the half-primer domains of (a) and (b) can combine linearly to form a full primer domain; (c) at least one docking strand capable of being stably bound to the full primer domain; and (d) at least one labeled imager strand capable of being stably bound to the docking strand or an intermediate strand capable of being stably bound to the docking strand and a labeled imager strand capable of being stably bound to the intermediate strand. The docking strand capable of being stably bound to the full primer domain includes complementary binding (noncovalent) and extending from the same nucleic acid strand (covalent binding). In embodiments where the docking strand is noncovalently bound to the full primer domain and has a complementary nucleic acid sequence, the docking strand may comprise a 5' domain, a 3' domain, and a linker domain located between the 5' domain and the 3' domain, wherein the 5' domain is complementary to the half-primer domain of (a) and the 3' domain is complementary to the half-primer domain of (b). In embodiments where the docking strand is covalently bound, it may be extended out from the full primer domain by nucleic acid synthesis. Additionally and alternatively, an intermediate strand may be used and be complementary to both the docking strand and the imager strand. Amplification may also be employed. The stability criteria set forth in Table 2 also apply in this context.

## D. Control Experiments and Background Subtraction

[0091] Control experiments and background subtraction may be employed to further improve the results of the methods of testing a sample for the presence of one or more targets. Neither of these aspects are required for useful experimentation; however, both improve the quality of multiplexing and can be used alone or in conjunction with each other.

### 1. Control Experiments

[0092] Control measurements may be added at multiple time points in a multiplexed process. In some embodiments, a method to test a fixed sample mounted to an optically transparent support for the presence of one or more targets comprises (1) contacting the sample with one or more target-specific binding partners, wherein each target-specific binding partner is linked to a nucleic acid strand and wherein target-specific binding partners of different specificity are linked to different nucleic acid strands, (2) optionally removing unbound target-specific binding partners, (3) wherein the nucleic acid strand is a docking strand or a primer strand and optionally if the nucleic acid is (a) a docking strand, increasing the number of docking strands associated with each target-specific binding partner or (b) a primer strand, associating more than one docking strand with the primer strand, (4) contacting the sample with labeled imager strands capable of binding a docking strand, either directly or indirectly, such as through an intermediate strand, (5) optionally removing unbound labeled imager strands, (6) imaging the sample to detect bound labeled imager strands, (7) extinguishing signal from the bound labeled imager strand, (8) performing a control step by contacting the sample with labeled imager strands having a nucleotide sequence that is ***not complementary*** to a docking strand or intermediate strand (i.e., one actually present in the method, if used, not a hypothetical intermediate strand), (9) optionally removing unbound labeled imager strands, (10) imaging the sample to detect bound labeled imager strands, and (11) optionally extinguishing signal from the bound labeled imager strand.

[0093] In some embodiments, a method to test a fixed sample mounted to an optically transparent support for the presence of one or more targets comprises (1) contacting the sample with one or more target-specific binding partners, wherein each target-specific binding partner is linked to a nucleic acid strand and wherein target-specific binding partners of different specificity are linked to different nucleic acid strands, (2) optionally removing unbound target-specific binding partners, (3) wherein the nucleic acid strand is a docking strand or a primer strand and optionally if the nucleic acid is (a) a docking strand, increasing the number of docking strands associated with each target-specific binding partner or (b) a primer strand, associating more than one docking strand with the primer strand, (4) performing a control step by contacting the sample with labeled imager strands having a nucleotide sequence that is *not complementary* to a docking strand or intermediate strand (i.e., one actually present in the method, if used, not a hypothetical intermediate strand), (5) optionally removing unbound labeled imager strands, (6) imaging the sample to detect presence, location, and/or number of bound labeled imager strands, (7) extinguishing signal from the bound labeled imager strand, (8) contacting the sample with labeled imager strands capable of binding a docking strand, either directly or indirectly, such as through an intermediate strand (9) optionally removing unbound labeled imager strands, (10) imaging the sample to detect presence, location, and/or number of bound labeled imager strands, and (11) optionally extinguishing signal from the bound labeled imager strand.

[0094] In either of the above two embodiments, in some instances, the method further comprises repeating steps (4)-(11). In some embodiments, the user would not repeat the control steps. In other embodiments, the user would repeat the control steps to assess noncomplementary binding.

[0095] In some of these embodiments, the labeled imager strand complementary to the docket strand used in the repeated steps optionally has a unique nucleotide sequence relative to at least one other labeled imager strands.

[0096] In some embodiments, the control experiment is used to assess crossbinding of noncomplementary strands to ensure in an example assessing targets A, B, and C (for example) that the imager strand (imager A) intended to bind to the docking strand (docking A) affixed to the target-specific binding partner (anti-A) for target A does not interact with the docking strand affixed to the target-specific binding partner for B (imager B) or to measure the degree of its interaction. In such embodiments, repeated processes may evaluate the interaction of imager C with docking strand A, etc. In these embodiments, the complementary strand (imager A binding to docking A) would not necessarily be repeated.

## **2. Background Subtraction**

[0097] In any of the embodiments discussed throughout this application, the method may employ background subtraction. In some embodiments, the method comprises imaging the sample to detect and/or measure a background signal and subtracting the background signal from the image of the sample to detect bound labeled imager strands. Such background signals may include autofluorescence and/or residual fluorescence associated with incompletely extinguishing signal from the bound labeled imager strands. In some aspects, the background signal is measured before the image of the sample to detect bound labeled imager strands. In other aspects, the background signal is measured after the image of the sample to detect bound labeled imager strands.

### **E. Methods of Extinguishing Signal from the Bound Labeled Imager Strand**

[0098] Various methods can be used to extinguish a signal from a bound labeled imager strand and this may be desired so that the same type of detectable moiety (such as a fluorophore) may be used on multiple imager strands so that the experiment is not spectrally limited.

[0099] In other words, removing the set of imager strands or inactivating the observable moieties on the imager strands allows for spectrally-unlimited multiplex imaging. Some prior methods of multiplex imaging were limited by the number of

colors of fluorophores or other imaging agents available. Removing the imager strands, removing labels from imager strands, or inactivating the observable moieties allows for reuse of the same colors of fluorophores in a single experiment. In some embodiments, ideally, as much of the signal should be removed to ensure as low backgrounds as possible for continued imaging. In some embodiments, 100% of the prior signal-generating moiety is removed or destroyed, while in some embodiments at least about 90%, 91%, 92%, 93%, 94%, 95%, 96%, 97%, 98%, or 99% of the prior signal-generating moiety is removed or destroyed.

[00100] Thus, extinguishing the signal from the labeled imager strand includes any method for removing the imager strand from binding, directly or indirectly, to the docking strand, removing the label from the imager strand, or inactivating the label on the imager strand.

[00101] All methods for extinguishing the signal from imager strands may be applied to docking strands as well. In some embodiments, extinguishing the signal from the bound labeled imager strand involves disrupting the link between docking strand (or primer strand) and target-recognition moiety. In some embodiments, the docking strand comprises a photocleavable linker that can be cleaved photochemically (e.g. by UV exposure, visible light, infrared, near infrared, x-ray, microwave, radio waves, or gamma rays). In some embodiments, the docking strand (or primer strand) itself contains a moiety that can be cleaved by an enzyme. Examples of such enzymatically cleavable moieties include but are not limited to ribonucleotides, which can be cleaved by a variety of RNases; deoxyuridines, which can be cleaved by enzyme combinations such as USER (New England Biolabs); and restriction sites, which can be cleaved by sequence-specific nicking enzymes or restriction enzymes. In some embodiments, the docking nucleic acid comprises a deoxyuridine, in which the uracil group may be cleaved by uracil-DNA glycosylase. In some embodiments, the docking nucleic acid comprises an abasic site, which may be cleaved by endonuclease.

[00102] One non-limiting example of Exchange Imaging is DNA Exchange Immunofluorescence, where one uses antibodies as the target-recognizing molecules to image target proteins or other biomolecules, uses DNA oligonucleotides as docking strands, and uses DNA oligonucleotides that are complementary to the docking strands and labeled with fluorophores as the imager strands. A user may extinguish the signal from the labeled imager strand by using high temperature, denaturant, DNA helicase, DNase, and/or strand displacement, or may remove the fluorophores on the imager strands by chemical cleavage, enzymatic cleavage, chemical bleaching, photo-bleaching, and/or photochemical bleaching.

### 1. Nucleic acid-degrading enzymes

[00103] A number of enzymes can break the covalent bonds within a nucleic acid molecule. For example, some glycosylase can remove the base from the sugar moiety of a nucleotide, endonuclease can cut the bond within the phosphodiester bridge inside the nucleic acid molecule, while exonuclease can similarly break the phosphodiester bridge at the 5' or 3' terminal of the nucleic acid molecule in a sequential fashion. Another example comprises DNAzymes or deoxyribozymes, oligonucleotides with catalytic activity capable of cleaving the phosphodiester bond in nucleic acid molecules. All these types of enzymes may be engineered for imager strand removal (**Figure 5**) and constitute enzymatically cleaving, modifying, or degrading the labeled imager strand nucleic acids.

[00104] **Glycosylase.** If a glycosylase can specifically remove a base that participates the base-pairing between the Docking Strand and the Imager Strand, it can reduce the strength of interaction between the two strands. For example, one can use deoxyuridine (dU) to replace deoxythymidine (dT) in the Imager Strand. dU can pair with dA in the Docking Strand just like the dT does, but can be specifically removed by Uracil-DNA Glycosylase (UDG, commercially available from New England Biolabs, Cat #M0280S). This reaction will result in abasic site(s) on the Imager Strand. Such abasic sites can be further cleaved by Endonuclease VIII. This will further promote the dissociation between the remnant of Imager Strand and the

Docking Strand. Enzyme blend comprising both UDG and Endonuclease VIII is also commercially available (e.g., from New England Biolabs, under the tradename USER, Cat# M5505S). One may place from about 1 to 20, 1 to 15, 1 to 10, or 1 to 5 dU nucleotides in the Imager Strand. With USER, the dUs may be placed in a way that after removal of U, the remnants are short enough (e.g., less than or equal to about 9, 8, 7, 6, 5, 4, 3, 2, or 1 nucleotides) that they dissociate spontaneously and quickly. If only UDG (i.e., no Endonuclease VIII) is used, the removal of dU units could destabilize the strand enough to facilitate removal. Total number of base pairs between the imager strand and docking strand after dU removal may be less than or equal to 9, 8, 7, 6, 5, 4, 3, 2, or 1 nucleotides. Thus, in some embodiments the imager strand or intermediate strand may comprise at least one U capable of cleavage by USER.

[00105] The sequence of the remnants, as well as the temperature, will impact how short the remnants should be to dissociate spontaneously. For example, a sequence high in GC content might have more binding affinity at a shorter length than another sequence at a longer length. Thus, in some instances, a 9-mer may be sufficient for stable binding and in other instances a 9-mer may be sufficient to dissociate. A person of ordinary skill in the art can evaluate the sequences, temperatures, and affinities, here and in the cleavage of non-natural nucleotides discussed below.

[00106] **Restriction endonuclease and nicking endonuclease.** One may engineer a restriction site in the docking strand:imager strand duplex. This allows the usage of the corresponding restriction endonuclease to cut such restriction site, which breaks the linkage between the target and the signal-generating moiety of the imager strand. As an example, Cas9 (CRISPR associated protein 9) is a RNA-guided endonuclease that can be used to specifically cleave docking: imager strand duplexes, by engineering a specific recognition site in the corresponding sequences. This results in both strands being cleaved, preventing one from re-interrogating the corresponding target. To solve this problem, one can use nicking endonuclease which

only cut one strand. As an example, Cas9 nickases are Cas9 enzymes that have been engineered to only include one active cleaving site, leading to single strand cuts, while conserving the high specificity of Cas9. One can design the restriction site in a way that only the imager strand is cut, and that the remnant of imager strand that carries the signal-generating moiety is sufficiently short (e.g., <7 nucleotide) that it dissociates spontaneously and quickly from the docking strand. Other examples of endonucleases with site specific activity include but are not limited to: zinc finger nucleases, transcription activator-like effector nucleases (TALENs), and deoxyribozymes.

[00107] **Rnase.** One may make some or all of nucleotides in the imager strand RNA nucleotides (also called ribonucleotides), instead of DNA nucleotides (also called deoxynucleotide). Such RNA nucleotides can be removed by Rnase. If the docking strand is comprised of DNA nucleotides and the imager strand contains RNA nucleotides, such RNA nucleotides in the DNA:RNA heteroduplex can be removed by Rnase H.

[00108] **Polymerase.** The imager strand can also be removed by using polymerases with strand-displacement activity or 5'-to-3' exonuclease activity. For example, one can engineer a hairpin structure at the 3' end of the docking strand made of DNA. When a DNA polymerase with strand displacement activity (e.g., Phi29, Bst, Vent) is introduced and supplied with suitable buffer and dNTPs, the 3' of the docking strand can be extended, during which the imager strand is displaced (Fig. 6c). The self-priming hairpin can also be engineered on the imager strand (Fig. 6a-b), for which the signal-general moiety can be either attached to the imager strand directly (Fig. 6a), or attached to the imager strand via DNA hybridization (Fig. 6b). When a DNA polymerase with 5'-to-3' exonuclease activity (e.g., DNA polymerase I, Taq) is introduced and supplied with suitable buffer and dNTPs, and a self-priming hairpin is engineered at the 3' end of the docking strand, the 3' can be extended, during which the imager strand is degraded (Fig. 6e). Similar effect can be achieved if the self-priming hairpin is engineered at the 3' end of the imager strand (Fig. 6d).

Note that the self-priming hairpin can also be replaced by a stable duplex (e.g., Fig. 6f).

[00109] **Cleavage of non-natural nucleotides.** Non-natural nucleotide that serve as substrates for particular enzymes may be used. For example, 8-oxoguanine may be cleaved by DNA glycosylase OGG1. Abasic sites may also be incorporated into a DNA strand, such as an imager strand, which may be cleaved by an endonuclease. For example, a 1',2'-Dideoxyribose, dSpacer, apurinic/aprimidinic, tetrahydrofuran, or abasic furan may be cleaved by Endonuclease VIII. Thus, in some embodiments the imager strand or intermediate strand may comprise at least one abasic site capable of cleavage by Endonuclease VIII. In some embodiments the imager strand or intermediate strand may comprise at least one deoxyuridine and at least one abasic site capable of cleavage by USER, UDG, or Endonuclease VIII. Photocleavable spacers or RNA abasic sites may also be used, such as ribospacer (rSpacer) or Abasic II modification. Other pairs of non-natural nucleotides and their paired enzymes may be employed.

[00110] Thus in some embodiments, a composition comprises (1) a label, (2) a first nucleic acid domain, a second nucleic acid domain, and a third nucleic acid domain, wherein each nucleic acid domain is from about 1 to 9 nucleotides long (for example, about 9, 8, 7, 6, 5, 4, 3, 2, or 1 nucleotides), (3) a first linking moiety linking the first nucleic acid domain and the second nucleic acid domain and (4) a second linking moiety linking the second nucleic acid domain and the third nucleic acid domain, wherein both linking moieties are independently chosen from (a) an abasic site with an intact phosphodiester backbone, (b) a linker cleavable by a nucleic acid glycosylase, or (c) a restriction site or nicking site. In some embodiments, additional nucleic acid domains are linked by additional linking moieties. In some embodiments, at least one linking moiety is an abasic site (apurimidinic) with an intact phosphodiester backbone. In some embodiments, at least one linking moiety is susceptible to cleavage from Endonuclease VIII. In some embodiments, the nucleic acid domains comprise DNA and in some the nucleic acid domains comprise RNA.

In some aspects, at least one linking moiety comprises at least one non-natural nucleotide. In some aspects, at least one linking moiety comprises 8-oxoguanine.

[00111] In some embodiments, methods of removing imager strand may be combined with amplification steps. In some embodiments, a method to test a sample for the presence of one or more targets comprises (1) contacting the sample with one or more target-specific binding partners, wherein each target-specific binding partner is linked to a nucleic acid strand, directly or indirectly and wherein target-specific binding partners of different specificity are linked to different nucleic acid strands, (2) optionally removing unbound target-specific binding partners, (3) wherein the nucleic acid strand is a docking strand or a primer strand and if the nucleic acid is (a) a docking strand, increasing the number of docking strands associated with each target-specific binding partner or (b) a primer strand, associating more than one docking strand with the primer strand, (4) contacting the sample with labeled imager strands capable of binding a docking strand, directly or indirectly, wherein the labeled imager strands comprise the composition described immediately above, (5) optionally removing unbound labeled imager strands, (6) imaging the sample to detect bound labeled imager strands, (7) removing the bound labeled imager strands from the docking strands, wherein the labeled imager strands are removed from the docking strands by enzymatically cleaving, modifying, or degrading the labeled imager nucleic acids, and (8) optionally repeating steps (1)-(7), or any subset thereof.

[00112] In some aspects, the labeled imager nucleic acids are removed by enzymatically cleaving the labeled imager strand.

## **F. Description of Samples**

### **1. Types of Samples**

[00113] Various types of samples may be imaged using these methods. In some embodiments, the sample is a fixed sample. In some embodiments, the sample is a cell, cell lysate, tissue, tissue lysate, and or a whole organism. In some embodiments, the sample is a cell or tissue sample, a cell or tissue lysate, or a bodily

fluid. In some embodiments, the sample is tissue and the imaging comprises in-tissue multiplexing for immunostaining.

[00114] The sample may be provided in a liquid medium or buffer solution.

## 2. Antigen Retrieval

[00115] In some embodiments, staining a sample with a target-specific binding partner requires specific conditions and not all target-specific binding partners will bind to their antigens under the same conditions. This may be because their target antigens are not available under the same conditions.

Thus in some embodiments, a method to test a sample for the presence of one or more targets comprises (1) treating the sample to expose one or more previously unavailable targets, (2) contacting the sample with one or more target-specific binding partners, wherein each target-specific binding partner is linked to a nucleic acid strand, and wherein target-specific binding partners of different specificity are linked to different nucleic acid strands, (3) optionally removing unbound target-specific binding partners, (4) wherein the nucleic acid strand is a docking strand or a primer strand and optionally if the nucleic acid is (a) a docking strand, increasing the number of docking strands associated with each target-specific binding partner or (b) a primer strand, associating more than one docking strand with the primer strand, (5) contacting the sample with labeled imager strands capable of binding a docking strand, directly or indirectly, (6) optionally removing unbound labeled imager strands, (7) imaging the sample to detect bound labeled imager strands, (8) extinguishing signal from the bound labeled imager strand, and (9) optionally repeating steps (1)-(8), each time (a) exposing a different set of previously unavailable targets (b) using one or more different target-specific binding partners and (c) using a labeled imager strand having a unique nucleotide sequence relative to at least one other labeled imager strand.

### 3. Description of Targets and Use in Identifying Biomarkers

[00116] In some embodiments, the method is useful for identifying a biomarker. In some instances, samples are imaged and data analysis performed on those samples. In some embodiments, multiple targets are tested for using corresponding target-specific binding partners for each target. In some instances, the relationship between different targets may be assessed; for example, a user might seek to determine the relationship of multiple markers to a disease state and conclude that the disease sample has increased levels of A, decreased levels of B, and levels of C within a certain range, as compared to healthy tissue that does not have that biomarker distribution.

[00117] In some embodiments, at least 10, 96, 100, 384, or 500 samples are imaged and data analysis performed on those samples.

[00118] In some embodiments, at least 5, 10, 15, 25, 30, 50, 75, or 100 or more targets are tested for using corresponding target-specific binding partners for each target.

## G. Equipment and Software

### 1. Imaging Chamber, Such as a Flow Cell

[00119] In some embodiments, an imaging chamber can be employed. In some instances, an imaging chamber is a fixed chamber with no inlet and no outlet. In some embodiments, an imaging chamber has a single inlet/outlet combination. In other instances, an imaging chamber allows for flow and is designated a flow cell. A flow cell may be comprised of a first optically transparent support in combination with a second optically transparent material (such as a glass or plastic coverslip) to provide a flow cell with a top and bottom surface and fluid flow between them. If a first and second optically transparent material are used, they may be placed parallel to each other. By parallel, it includes geometrical arrangements that are perfectly parallel, as well as those that deviate from parallel by up to 1°, 2°, 3°, 4°, 5°, 6°, 7°, 8°, 9°, or 10°. In some embodiments, the second optically transparent material is in close proximity to the first optically transparent material,

such as about 5 microns to 5 mm, from 50 microns to 500 microns, or from 500 microns to 5 mm.

[00120] An imaging chamber may also be comprised of a first optically transparent support and a gasket (also referred to as an isolator or spacer). The gasket may be open to the air on the top surface or it may be closed and have an optically transparent top surface. The gasket may have a combined inlet/outlet or it may have both an inlet and an outlet. The gasket may also have no outlet. The gasket may be plastic, rubber, adhesive. A gasket may comprise a CoverWell Chamber Gasket (Thermo Fisher), an ultra-thin sealed chamber for upright and inverted microscopes (Bioscience Tools), or an incubation chamber (Grace Bio-Labs, including HybriSlip™ hybridization covers, HybriWell™ sealing system, CoverWell™ incubation chambers, imaging spacers, SecureSeal™ hybridization chambers, FlexWell™ incubation chambers, FastWells™ reagent barriers, and Silicone Isolators™).

[00121] In some instances, a gasket may be employed along with a coverslip forming the top surface of an imaging chamber or flow cell.

[00122] Imaging chambers, such as but not limited to flow cells, may be reusable or disposable.

[00123] Thus, in some embodiments, a method to test a fixed sample mounted to a first optically transparent support for the presence of one or more targets comprises (1) contacting the sample with one or more target-specific binding partners, wherein each target-specific binding partner is linked to a nucleic acid strand and wherein target-specific binding partners of different specificity are linked to different nucleic acid strands, (2) optionally removing unbound target-specific binding partners, (3) wherein the nucleic acid strand is a docking strand or a primer strand and optionally if the nucleic acid is (a) a docking strand, increasing the number of docking strands associated with each target-specific binding partner or (b) a primer strand, associating more than one docking strand with the primer strand, (4) in an imaging chamber (such as a flow cell), contacting the sample with labeled imager

strands capable of binding a docking strand, directly or indirectly, (5) optionally removing unbound labeled imager strands, (6) imaging the sample to detect presence, location, and/or number of bound labeled imager strands and optionally removing the imaging chamber, (7) extinguishing signal from the bound labeled imager strand, and (8) repeating steps (4)-(6) or (4)-(7), at least once with a labeled imager strand optionally having a unique nucleotide sequence relative to at least one other labeled imager strands.

[00124] A method to image a fixed sample mounted to an optically transparent support comprising (1) contacting the sample with one or more target-specific binding partners, wherein each target-specific binding partner is linked to a nucleic acid strand, and wherein target-specific binding partners of different specificity are linked to different nucleic acid strands, (2) optionally removing unbound target-specific binding partners, (3) wherein the nucleic acid strand is a docking strand or a primer strand and if the nucleic acid is (a) a docking strand, increasing the number of docking strands associated with each target-specific binding partner or (b) a primer strand, associating more than one docking strand with the primer strand, (4) contacting the sample with labeled imager strands capable of binding a docking strand, either directly or indirectly, (5) optionally removing unbound labeled imager strands, (6) optionally removing liquid to create a liquid-free sample, (7) affixing a second optically-transparent material in close proximity to (namely about 5 microns to 5 mm, from 50 microns to 500 microns, or from 500 microns to 5 mm) and parallel to the first support, and (8) imaging the sample to detect bound labeled imager strands.

## **2. Software for Control of Fluidic Steps**

[00125] In some embodiments, all fluidic exchange steps are performed using a fluidic system comprising electronic, and/or pneumatic, and/or hydraulic, and/or electro-fluidic actuators and systems. In certain situations, the fluidic system is controlled by software. In some embodiments, wherein the fluidic system is automatically controlled by software synchronizing steps (1 (contacting a sample with

target-specific binding partners) and/or 2 (optionally removing unbound target-specific binding partners) and/or 3 (increasing the number of docking strands, or amplification) and/or 4 (contacting the sample with labeled imager strands capable of binding a docking strand, directly or indirectly) and/or 5 (optionally removing unbound labeled imager strands), and/or 7 (optionally removing the bound labeled imager strands from the docking strands) with the imaging step (6).

[00126] In some embodiments, the fluidic system is controlled by software synchronizing the steps (1 and/or 2 and/or 3 and/or 4 and/or 5, and/or 7) with the imaging step (6) by communicating with the imaging software, with the references to step numbers described in the preceding paragraph.

[00127] In some embodiments, all fluidic steps are performed while the sample is on the imaging device. In some embodiments, steps 4, 5, and 7 are performed while the sample is on the imaging device, with the references to step numbers described two paragraphs previously.

[00128] The sample may be fixed in a disposable imaging chamber (such as a flow cell) or a reusable imaging chamber (such as a flow cell).

## **H. Kits**

[00129] In some embodiments, a composition comprises (1) one or more reagent(s) including but not limited to target-specific binding partners linked to docking-strands, wherein target-specific binding partners of different specificity are linked to different docking strands, labeled imager strands, buffers, amplification reagents, and/or reagents to remove bound imager strands, (2) a fluidic system to perform all fluid exchange steps, a software to control the fluidic system and time and/or synchronize the fluidic steps with the imaging steps, (3) an imaging chamber (such as a flow cell) to affix on the sample of interest with at least one optically transparent side to allow imaging of the sample. In some embodiments, the imaging chamber (such as a flow cell) is disposable.

## II. Components of the Method

### A. Target-Specific Binding Partners

[00130] The target recognition moiety refers to antibodies and antibody-like molecules that can be used to detect the target molecule. Antibody refers to any immunoglobulin from any species that can specifically recognize a target molecule. Antibody-like molecule refers to (Class A) any engineered variation or fragment of an antibody such as Fab, Fab', F(ab')<sub>2</sub>, single heavy chain, diabody, and the like (antigen binding fragments of antibodies) (Class B) any known binding partner of a target molecule and engineered variants of such binding partner, (Class C) any binding partner of the target molecule engineered via directed evolution (e.g., peptides and aptamers), and (Class D) any molecule that selectively forms covalent bond(s) with a target (e.g., a suicide substrate of an enzyme of interest).

[00131] The target-specific binding partner may be provided in a liquid medium or buffer solution.

[00132] Table 3 provides a representative listing of targets and corresponding target recognition moieties.

<b>Table 3: Representative Targets and Target Recognition Moieties</b>		
<b>Target</b>	<b>Target Recognition Moiety</b>	<b>Source or Sequence</b>
Any protein	Antibody (Class A)	Variable
Fluorescein (chemical compound)	Antibody (Class A)	Abcam, product # ab7253
Digoxigenin (chemical compound)	Antibody (Class A)	Abcam, product # ab76907
Biotin	Avidin/Streptavidin (Class B)	
Epidermal growth factor receptor (EGFR, protein)	Epidermal growth factor (EGF, Class B)	

Platelet-derived growth factor receptor (PDGFR, protein)	Platelet-derived growth factor (PDGF, Class B)	
Epidermal growth factor receptor (EGFR, protein)	E07 aptamer (Class C)	Li et al., PloS ONE, 2011;6(6):e20299
Integrins (protein)	RGD-containing peptides (Class B)	
TNF- $\alpha$ (protein)	T09.12 peptide (Class C)	Xu et al., Chem Biol. 2002 Aug;9(8):933-42.
HaloTag (enzyme)	Halogenated compounds (Class D)	Bioconjug Chem. 2015 Jun 17;26(6):975-86.
Oxidosqualene cyclase (OSC, enzyme)	[3H]29-methylidene-2,3-oxidosqualene ([3H]29-MOS, Class D)	Biochem Biophys Res Commun. 1992 Aug 31;187(1):32-8.

[00133] Table 4 provides a listing of additional targets. Antibodies and other known binding partners of these targets may be used as target recognizing moieties.

<b>Table 4: Additional Representative Targets</b>		
Actin	EGFR	MMP
AIF	EpCAM	mTOR
AKT	ER	MYC
alpha-synuclein	ERK	NeuN
amyloid precursor protein	ERK	p21
annexin	FOXA	p53
arrestin	FOXP3	PAX
BAD	GABA	PD-1
BAX	GAPDH	PD-L1
Bcl-2	GFP	PI3K

Bcl-2	granzymeB	PR
beta-catenin	GRB2	PSD95
BRCA1	HER2	RAS
cAMP	HER3	SOX
caveolin	HIF-1	STAT
CD20	histoneH3	synapsin
CD3	HSP27	Tau
CD4	HSP70	TOM20
CD45	HSP90	tubulin
CD68	keratin	ubiquitin
CD8	Ki67	VEGF
collagen	lamin	vimentin
CREB	MAPK	WNT
DNA	MEK	
E-Cadherin	MET	

## B. Docking Strands

[00134] In some embodiments, the docking moiety or docking strand is a nucleic acid, a protein, a peptide, or a chemical compound. Many proteins and domains of proteins are known to interact with other proteins, domains or peptides. Some of the best-known domains include SH2, SH3, and WD40 domains. In many cases the binding partner of these proteins and domains are known and can be engineered to have the desired affinity. For example, biotin and avidin/streptavidin interact with sufficient specificity. Many other chemical compounds, such as digoxigenin, fluorescein, tacrolimus and rapamycin also have well known binding partners.

[00135] In some embodiments, the docking strand comprises nucleic acids. In some embodiments, the nucleic acids are single stranded nucleic acids such as single stranded DNA, RNA, or a nucleic acid analog. A nucleic acid analog (also

known as non-natural nucleic acid) may include an altered phosphate backbone, an altered pentose sugar, and/or altered nucleobases. Nucleic acid analogs may include, but are not limited to, 2'-O-Methyl ribonucleic acid, 2'-fluoro ribonucleic acid, peptide nucleic acid, morpholino and locked nucleic acid, glycol nucleic acid, and threose nucleic acid.

[00136] In some embodiments, the docking strand is attached to the imager strand covalently and in other embodiments noncovalently.

[00137] In some embodiments, the docking strand comprises single-stranded nucleic acids and may be from about 5 to 20 nucleotides long, from about 8 to 15, or from about 10 to 12 nucleotides long. In some embodiments, the docking strand is about 5, 8, 9, 10, 11, 12, 13, 14, 15, 18, or 20 nucleotides long.

[00138] The docking strand may be an independent element or it may be part of the target recognizing moiety. For example, if the target recognizing moiety is an antibody, part of the Fc domain of the antibody may be the docking strand and a peptide or protein that binds the Fc domain may be used, such as protein A or protein G.

[00139] The docking strand may be provided in a liquid medium or buffer solution.

### **C. Imager Strands**

[00140] In some embodiments, the docking strand may be a nucleic acid strand. In such cases, the observable moiety or label may be conjugated to an imager moiety, which may be a nucleic acid strand that is complementary to the docking strand. In other words, the imager strand specifically binds the docking strand. In such a case, the label may be conjugated to an imager moiety that may be from about 5 to 20 nucleotides long, from about 8 to 15, or from about 10 to 12 nucleotides long. In some embodiments, the imager moiety is about 5, 8, 9, 10, 11, 12, 13, 14, 15, 18, or 20 nucleotides long.

[00141] In some embodiments, the imager strand is even longer, such as from 20 to 80 nucleotides long, for example less than or equal to 80, 75, 70, 65, 60,

55, 50, 45, 40, 35, or 30 nucleotides long. In embodiments employing a hairpin structure for the imager strand, the length of the imager strand may be longer than if no hairpin structure is used.

[00142] In some embodiments, the complementary portions between the imager moiety and the docking strand may be from about 5 to 20 nucleotides long, from about 8 to 15, or from about 10 to 12 nucleotides long. In some embodiments, the complementary portions between the imager moiety and the docking strand may be about 5, 8, 9, 10, 11, 12, 13, 14, 15, 18, or 20 nucleotides long.

[00143] In some embodiments, the nucleic acid imager strand comprises single stranded nucleic acids such as single stranded DNA, RNA, or a nucleic acid analog. A nucleic acid analog (also known as non-natural nucleic acid) may include an altered phosphate backbone, an altered pentose sugar, and/or altered nucleobases. Nucleic acid analogs may include, but are not limited to, 2'-O-Methyl ribonucleic acid, 2'-fluoro ribonucleic acid, peptide nucleic acid, morpholino and locked nucleic acid, glycol nucleic acid, and threose nucleic acid.

[00144] In some embodiments, the imager moiety is a protein, peptide, or a chemical compound, as a partner to the docking strand options discussed above in Section II.B above.

[00145] In some embodiments, the docking strand may bind to the imager moiety indirectly, such as through an intermediate moiety. For instance, when the docking strand and the imager moiety are nucleic acids, an intermediate moiety comprising nucleic acids may be used as long as the intermediate moiety has a first region complementary to the docking strand and a second region complementary to the imager moiety. In this embodiment, it is not necessary for the docking strand to be complementary to the imager moiety. The intermediate moiety may serve only a bridging function or it may also serve an amplification function.

[00146] The imager strand may be provided in a liquid medium or buffer solution.

#### D. Primer Strands

[00147] In some instances, the target-specific binding partner is linked indirectly to a docking strand, such as through a primer. For instance, when the docking moiety and the imager moiety comprise nucleic acids, the primer strand comprising nucleic acids may be used as a binding location for the docking strand (if the docking strand has a region complementary to the primer strand) or it may be used as a primer for nucleic acid synthesis through, for example, rolling circle amplification. The primer strand may also be used to initiate the cascade of binding events in hybridization chain reaction amplification. In instances where the primer serves as a location for amplification (such as rolling circle amplification, hybridization chain reaction amplification), the primer is not necessarily complementary to the docking strand. Instead, it serves as a template for amplification and the docking strands are included through the amplification process.

[00148] In some embodiments, the target-specific binding partner and linked primer are added to the sample as a first step, docking strand added as a second step, and imager strand added as a third step. In another embodiment, the components are not added in discrete steps. Washing steps may be added between the first, second, and/or third steps.

[00149] In some embodiments, the primer strand comprises nucleic acids. In some embodiments, the nucleic acids are single stranded nucleic acids such as single stranded DNA, RNA, or a nucleic acid analog. A nucleic acid analog (also known as non-natural nucleic acid) may include an altered phosphate backbone, an altered pentose sugar, and/or altered nucleobases. Nucleic acid analogs may include, but are not limited to, 2'-O-Methyl ribonucleic acid, 2'-fluoro ribonucleic acid, peptide nucleic acid, morpholino and locked nucleic acid, glycol nucleic acid, and threose nucleic acid.

[00150] In some embodiments, the primer strand comprises single-stranded nucleic acids and may be from about 5 to 20 nucleotides long, from about 8 to 15, or from about 10 to 12 nucleotides long. In some embodiments, the primer

strand is about 5, 8, 9, 10, 11, 12, 13, 14, 15, 18, 20, 25, 30, 35, 40, 45, 50, 55, 60, 65, or 70 nucleotides long.

[00151] The primer strand may be provided in a liquid medium or buffer solution.

#### **E. Intermediate Strands**

[00152] In some instances, the docking strand binds to the imager strand through an intermediate moiety (or intermediate strand). For instance, when the docking moiety and the imager moiety comprise nucleic acids, the intermediate strand comprising nucleic acids may be used as long as the intermediate strand has a first region complementary to the docking strand and a second region complementary to the imager strand. In such embodiments, it is not necessary for the docking strand to be complementary to the imager moiety.

[00153] In some embodiments, the intermediate strand is added as a first step to a sample comprising the target-specific binding partner linked to a docking strand, either directly or indirectly, and the imager strands added as a second step. In another embodiment, the intermediate strand and imager strand are not added in discrete steps. In some instances, the intermediate strand and imager strand are hybridized together before being added in a single step.

[00154] In some embodiments, the intermediate strand comprises nucleic acids. In some embodiments, the nucleic acids are single stranded nucleic acids such as single stranded DNA, RNA, or a nucleic acid analog. A nucleic acid analog (also known as non-natural nucleic acid) may include an altered phosphate backbone, an altered pentose sugar, and/or altered nucleobases. Nucleic acid analogs may include, but are not limited to, 2'-O-Methyl ribonucleic acid, 2'-fluoro ribonucleic acid, peptide nucleic acid, morpholino and locked nucleic acid, glycol nucleic acid, and threose nucleic acid.

[00155] In some embodiments, the intermediate strand comprises single-stranded nucleic acids and may be from about 5 to 30 nucleotides long, from about 8 to 15, or from about 10 to 12 nucleotides long. In some embodiments, the

intermediate strand is about 5, 8, 9, 10, 11, 12, 13, 14, 15, 18, 20, 25, or 30 nucleotides long.

[00156] The intermediate strand may be provided in a liquid medium or buffer solution.

#### **F. Nucleic Acids in Hairpin Format**

[00157] Any of the linear nucleic acids described herein may optionally be provided in a hairpin format. This includes the imager strand, docking strand, primer strand, and intermediate strand. In the hairpin format, a region of from at least 1-5 nucleotides at the end of the hairpin stem region may optionally comprise only G's and C's. This G/C region is known as a clamp. The G/C region prevents or reduces fraying at the end of the hairpin to prevent opening up into linear DNA.

[00158] A hairpin may be used in contexts when a user desires to break the interaction (direct or indirect) between the imager strand and the docking strand using a polymerase with a strand-displacement activity (e.g., phi29) or a polymerase with a 5'-to-3' exonuclease activity (e.g., DNA Polymerase I). A hairpin may also be used to limit unwanted binding of single-stranded nucleic acids.

#### **G. Labels**

[00159] Various labels, also known as observable moieties, may be bound to the imager strand. These labels or observable moieties assist the user by enabling detection of the bound imager strand. When the application refers to detecting bound labeled imager strands, the application references detecting the signal produced by the label or observable moiety bound to the imager strand.

[00160] In some embodiments, any observable moiety may be employed and, in some embodiments, the moiety is optically observable. The moiety may be signal absorbing or signal emitting. Of signal emitting molecules, molecules that fluoresce may be used, such as organic small molecules, including, but not limited to fluorophores, such as, but not limited to, fluorescein, Rhodamine, cyanine dyes, Alexa dyes, DyLight dyes, Atto dyes, etc.

[00161] In some embodiments, organic polymers, such as p-dots may be employed. In some embodiments, the observable moiety may be a biological molecule, including but not limited to a fluorescent protein or fluorescent nucleic acid (including fluorescent RNAs including Spinach and its derivatives). In some embodiments, the observable moiety may be an inorganic moiety including Q-dots. In some embodiments, the observable moiety may be a moiety that operates through scattering, either elastic or inelastic scattering, such as nanoparticles and Surface Enhanced Raman Spectroscopy (SERS) reporters (e.g., 4-Mercaptobenzoic acid, 2,7-mercapto-4-methylcoumarin). In some embodiments, the observable moiety may be chemiluminescence/ electrochemiluminescence emitters such as ruthenium complexes and luciferases. The observable moiety may generate an optical signal, an electromagnetic signal (across the entire electromagnetic spectrum), atomic/molecular mass (e.g. detectable by mass spectrometry), tangible mass (e.g., detectable by atomic force microscope), current or voltage.

## EXAMPLES

### Example 1: Multiple modes of amplification

[00162] There are multiple approaches to amplification. This example demonstrates the use of three approaches including enzymatic amplification using HRP conjugates (Figure 7A-C), rolling circle amplification (Figure 7D-E), and hybridization chain reaction (HCR) (Figure 7F-G).

[00163] For HRP-based amplification, formalin-fixed paraffin-embedded (FFPE) tonsil tissue sections were dewaxed and antigen-retrieved using R-Buffer A (Fisher Scientific) in a Lab Vision PT-module. Tissue sections were blocked in 3% BSA and 0.2% Triton-X 100 for 1.5 hours. Tissue sections were stained with a mouse anti-cytokeratin primary antibody overnight at 4°C in a humidity chamber. Tissue sections were then washed with 1x PBS, and stained for 2 hours at room temperature with a goat anti-mouse secondary antibody conjugated to a DNA docking strand (D1). Tissue sections were washed again in 1x PBS, and stained for DAPI.

[00164] A fluorescence microscope was used to image the tissue section in the DAPI and Cy5 channels to serve as a blank. An imager strand (I1-650), comprising a red fluorophore attached to DNA that includes a domain complementary to a docking strand D1, was added to the prepared tissue section and allowed to hybridize for 25 minutes at room temperature. Sections were washed to remove unbound I1-650. Then, fluorescence images were captured in the DAPI and Cy5 channels using a 10x objective. See Figure 7B.

[00165] The imager strand I1-650 was then removed by applying 10 units of USER enzyme to the tissue sections for 15 minutes at room temperature, washing with 1x PBS, incubating the tissue sample with 30% formamide for 5 minutes, then washing with 1x PBS. A fluorescence microscope was used to confirm the complete removal of fluorescent signal in the Cy5 channel. Then a brightfield image was taken at 10x magnification as a blank.

[00166] To amplify the cytokeratin signal for brightfield immunohistochemical detection, the tissue section was incubated with an imager strand (I1-HRP), comprising a horseradish peroxidase (HRP) enzyme attached to DNA that includes a domain complementary to docking strand D1. The sample was washed by submerging the tissue section in 1x PBS. Then, chromogenic signal amplification was carried out by applying a solution of 3,3'-diaminobenzidine (DAB) chromogen to the sample for 10 minutes. The sample was washed in 1x PBS. Finally, the sample was imaged using brightfield illumination. Figure 7C.

[00167] Figure 7A-C illustrate the use of DNA Exchange to enable fluorescence and brightfield (e.g. immunohistochemistry) images to be captured on the same sample. While this example demonstrates the use of HRP-conjugated imager strands for chromogenic signal amplification, HRP-conjugated imager strands could also be applied for fluorescent signal amplification using alternative enzyme substrates (e.g. tyramide).

[00168] In a separate approach for amplification based on rolling circle amplification, cultured HeLa cells were fixed with warm 3% paraformaldehyde and

0.1% glutaraldehyde, reduced with 0.1% sodium borohydride, blocked and permeabilized with 3% bovine serum albumin and 0.2% Triton-X 100, and then stained with a rabbit primary antibody against vimentin overnight.

[00169] For a control sample, a goat-anti-rabbit antibody conjugated to a docking strand (Gt-a-Rb-D1) was incubated with the cells for 2 hours at room temperature as a secondary staining step. After washing the control sample, DAPI and 100 nM fluorescently labeled imager strands were added to the sample. Fluorescence images in the DAPI and Cy5 channels were collected of the control well. Figure 7D.

[00170] The following procedure was carried out for cell samples undergoing rolling circle amplification. A goat-anti-rabbit antibody conjugated to a docking strand (Gt-a-Rb-D1), was used as a template for ligation. A ligation solution was made in a PCR tube with 125 nM circle oligo (IDT DNA), 125 nM Gt-a-Rb-D1, 20 U/ $\mu$ L T4 ligase (NEB), in 1x ligation buffer (NEB). The ligation solution was incubated at room temperature for two hours. After ligation, the ligation solution was diluted 1:5 in blocking buffer, added to the cell samples, and allowed to incubate for 2 hours at room temperature, then washed in 1x PBS.

[00171] In a separate vessel, a polymerase solution was made containing 0.1 mg/mL BSA, 0.2 mM dNTPs, and 1 U/ $\mu$ L phi29 DNA Polymerase in 1x polymerase reaction buffer (New England Biolabs). The polymerase solution was applied directly to the cell samples that were prepared for RCA. The samples were incubated with the polymerase solution for 1.5 hours at 30°C. The cell samples were washed three times with 1x PBS. DAPI was added to stain the cell nuclei. Finally, 100 nM fluorescently labeled imager strands were added prior to imaging. Fluorescence images in the DAPI and Cy5 channels were collected following RCA. See Figure 7E.

[00172] In a separate approach for amplification based on a hybridization chain reaction, formalin-fixed paraffin-embedded (FFPE) tonsil tissue sections were dewaxed and antigen-retrieved using R-Buffer A (Fisher Scientific) in a Lab Vision PT-module. Tissue sections were blocked in 3% BSA and 0.2% Triton-X

100 for 1.5 hours. Tissue sections were stained with a mouse anti-cytokeratin primary antibody overnight at 4°C in a humidity chamber. Tissue sections were then washed with 1x PBS, and stained for 2 hours at room temperature with a goat anti-mouse secondary antibody conjugated to a DNA docking strand (D1). Tissue sections were washed again in 1x PBS, and stained for DAPI.

[00173] A fluorescence microscope was used to image the tissue section in the DAPI and Cy5 channels to serve as a blank. An imager strand (I1-650), comprising a red fluorophore attached to DNA that includes a domain complementary to a docking strand D1, was added to the prepared tissue section and allowed to hybridize for 25 minutes at room temperature. Sections were washed to remove unbound I1-650. Then, fluorescence images were captured in the DAPI and Cy5 channels using a 10x objective. See Figure 7F.

[00174] The imager strand I1-650 was then removed by applying 10 units of USER enzyme to the tissue sections for 15 minutes at room temperature, washing with 1x PBS. A fluorescence microscope was used to confirm the complete removal of fluorescent signal in the Cy5 channel (data not shown).

[00175] After removal of the imager strand, a primer strand including the I1 sequence was hybridized to the D1 docking strand (20 nM) for 30 minutes at room temperature. The sections were washed with 1X PBS to wash the unbound primer strands. In parallel, hairpin strands H1 and H2-D2 were diluted to 1uM in 5x SSX in separate microcentrifuge tubes. The tubes were heated and held at 90°C for 5 minutes, and then slowly cooled down to room temperature. The hairpins were then pooled and diluted to 200 nM in 5X SSC with 0.1% Tween 20 and 10% dextran sulfate. This solution was added to the tissue section and incubated overnight in an incubation chamber at room temperature. The sections were then washed with PBS 1x. Finally, 100 nM fluorescently labeled imager strands I2 were added prior to imaging. Fluorescence images in the DAPI and Cy5 channels were collected following HCR amplification. Figure 7G, right.

**Example 2: Amplification with pre-ligated circle oligo**

[00176] Nonlinear DNA strands were made in advance of performing an assay. Using nonlinear DNA strands provides the benefit that it may increase the efficiency of signal amplification, particularly if the signal amplification method used is similar to rolling circle amplification (Figure 8). In this example, a circular DNA strand was made via a ligation step. The DNA sequence used in the ligation step was referred to as the circle oligo, which includes a domain that is equivalent to an imager strand sequence (i.e. complementary to a docking strand).

[00177] Cultured HeLa cells were fixed with warm 3% paraformaldehyde and 0.1% glutaraldehyde, reduced with 0.1% sodium borohydride, blocked and permeabilized with 3% bovine serum albumin and 0.2% Triton-X 100, and then stained with a rabbit primary antibody against vimentin overnight. A goat-anti-rabbit antibody conjugated to a docking strand (Gt-a-Rb-D1), was then used as a secondary stain and allowed to incubate for 2 hours at room temperature.

[00178] A ligation solution was made in a PCR tube with 0.5  $\mu$ M circle oligo (IDT DNA), 50  $\mu$ M ATP, 2.5 mM  $MnCl_2$ , 5 U/ $\mu$ L CircLigase (Cat# CL4111K, EpiCentre), in 1x reaction buffer (EpiCentre). The ligation solution was placed in a thermocycler for 1 hour to incubate at 60°C. After ligation, a 1:4 dilution of the ligation solution was made in blocking buffer, added to the stained cell samples, and allowed to incubate for 25 minutes to hybridize to a docking strand on an antibody-labeled target complex before washing in PBS.

[00179] As an alternative approach, the ligation step can be carried out prior to staining the sample with a secondary antibody conjugate. Following the ligation step, an excess of ligation solution was hybridized to an antibody DNA conjugate such that the molar ratio of ligated circle oligo was at least two-fold greater than the molar ratio of docking strands bound to the antibody. After hybridization of the ligated circle oligo to Gt-a-Rb-D1, the complex was added to the sample and incubated for two hours at room temperature as a secondary staining step, then washed three times in 1x PBS.

[00180] In a separate vessel, a polymerase solution was made containing 0.1 mg/mL BSA, 0.2 mM dNTPs, and 1 U/ $\mu$ L phi29 DNA Polymerase in 1x polymerase reaction buffer (New England Biolabs). The polymerase solution was applied directly to a fixed cell sample that was already stained with a primary antibody, a secondary antibody docking strand conjugate, and hybridized to a ligated circle oligo. The sample was incubated with the polymerase solution for 1.5 hours at 30°C. The cell samples were washed three times with 1x PBS. DAPI was added to stain the cell nuclei. Finally, 100 nM fluorescently labeled imager strands were added prior to imaging. Figure 8 shows the use of pre-formed nonlinear DNA strands that can be hybridized to docking strands as a starting point for rolling circle polymerization.

### **Example 3: Sample re-interrogation (0-A-0-A)**

[00181] This example demonstrates the ability to use Exchange Imaging to reinterrogate a target in a sample. It also shows that the enzymatic method of extinguishing signal does not affect, modify, or degrade the staining of the sample.

[00182] In this example, docking strands (D1 and D2) were conjugated to secondary antibodies goat anti-mouse and goat anti-rabbit respectively. The imagers strands I1U and I2U, respectively complementary to D1 and D2, were labeled with a fluorescent dye (ATTO647N). The sequence of the imager strands I1U and I2U includes several uracil nucleobases. An enzyme, or cocktail of enzymes, can cleave bases leading to the dehybridization of the docking-imager duplex, leading to a decrease in the observed signal.

[00183] Cultured HeLa cells were fixed with warm 3% paraformaldehyde and 0.1% glutaraldehyde, reduced with 0.1% sodium borohydride, blocked and permeabilized with 3% bovine serum albumin and 0.2% Triton-X 100 in 1X PBS for 1.5 hours. The cells were first stained using a cocktail of primary antibodies anti-tubulin and anti-TOM20, raised in mouse and rabbit respectively, overnight at 4 °C. Goat secondary antibodies against mouse and rabbit conjugated to two different docking strands (Gt-a-Ms-D1 and Gt-a-Rb-D2) were used for a

secondary staining for 2 hours at room temperature. DAPI was added to stain the cell nuclei.

[00184] Samples were loaded onto an inverted Nikon Eclipse Ti microscope (Nikon Instruments) with a fluorescence module and an Andor Zyla sCMOS camera. The microscope was equipped with two fluorescence filter sets to image DAPI and the fluorescently labeled imager strands (Cy5 channel).

[00185] The sample was first imaged using a 20x dry objective (Nikon, 0.45 NA), in both DAPI and Cy5 channels to register the cells using DAPI, and to measure the autofluorescence signal in the Cy5 channel (Figure 9A). A solution of 100 nM I1U was added to the sample and incubated for 15 minutes. The sample was then washed 3 times with 1X PBS, and imaged again (Figure 9B). To extinguish the signal, a solution containing 5 units of USER™, 50 mM potassium acetate, 20 mM tris-acetate, 10 mM magnesium acetate, and 100 µg/ml BSA, was added to the sample, and incubated at room temperature for 15 minutes. The sample was then washed 3 times with PBS 1x, and imaged (Figure 9C). A solution of 100 nM I2U was added to the sample and incubated for 15 minutes. The sample was then washed 3 times with 1X PBS, and imaged (Figure 9D). The signal was extinguished as previously, and the sample was imaged again (Figure 9E). Finally, a solution of 100 nM I1U was added to the sample and incubated for 15 minutes. The sample was washed 3 times with 1X PBS, and imaged (Figure 9F).

[00186] Figure 9 shows the series of images obtained in the Cy5 channel during this experiment. In Figure 9A, 8C, and 8E, no signal is observed. These images correspond to: before introduction of imager strand, after removal of I1U, and after removal of I2U respectively. After addition of the imager strand I1U, the microtubule networked is observed (Fig 8B, 8F). Fig. 8D shows the presence of mitochondria after adding I2U. Figure 9G presents the average signal intensity in the images of Figures 9A-F. The signal decreases by more than 98% in both cases shown in Figure 9C and 8E. The signal recovery on the microtubule target after two rounds

of exchange is over 95%, demonstrating the ability to reliably reinterrogate a target after multiple exchange steps.

[00187] The images in Figures 9A-F were obtained by manually pipetting the incubation and wash solutions in and out of the imaging chambers. The Exchange Imaging workflow can be automated by using flow cells and a fluidic system.

[00188] Using a fluidics system synchronized with the acquisition software of the microscope, the fluidics steps required for the hybridization of the imager strand (injections, incubation, washes), as well as the signal removal can be automatically performed between imaging rounds.

[00189] HeLa cells were cultured, fixed, and stained as described above, in a flow cell, which can be fitted on a regular microscope stage. The sample was first imaged using a 20x dry objective (Nikon, 0.45 NA), in both DAPI and Cy5 channels to register the cells using DAPI, and to measure the autofluorescence signal in the Cy5 channel (Figure 9, Image H). A solution of 100 nM I1U was flowed into the sample chamber and incubated for 15 minutes. The sample was then washed with 1X PBS with continuous flow for 30 seconds, and imaged again (Figure 9I). Next, a solution containing 5 units of USER™, 50 mM potassium acetate, 20 mM tris-acetate, 10 mM magnesium acetate, and 100 µg/ml BSA, was injected into the flow cell, and incubated for 15 minutes. The sample was then washed for 30 seconds with PBS 1X, and imaged (Figure 9J). Finally, the solution of imager I1U was injected again into the flow cell, incubated for 15 minutes, washed with PBS for 30 seconds. The sample was imaged one last time (Figure 9K).

#### **Example 4: Proximity detection with stable binding**

[00190] A pair of proximity probes (PL and PR) were conjugated to anti-mouse antibodies using the ThunderLink kit (Innova Biosciences). Cultured HeLa cells were fixed with warm 3% paraformaldehyde and 0.1% glutaraldehyde, reduced with 0.1% sodium borohydride, blocked and permeabilized with 3% bovine serum albumin and 0.2% Triton-X 100, and then stained with a mouse primary

antibody against alpha-tubulin. Fixed cells were then stained with a mixture of PL- and PR-conjugated secondary antibodies, and washed to remove any unbound material. A large fraction of anti-alpha-tubulin antibodies in the sample should receive at least one molecule of PL-conjugated secondary antibody and at least one molecule of PR-conjugated antibody. To detect proximity signal, DAPI and 100 nM of imager strand was added to the sample, and the sample was imaged with wide-field fluorescence microscope at 20x, with an LED light source (Figure 10A (top panel)).

[00191] In a negative control experiment (Figure 10, bottom panel), one of the proximity probes was conjugated to an off-target, anti-rabbit secondary antibody. Fixed cells were stained with mouse anti-tubulin primary, PL-conjugated anti-mouse and PR-conjugated anti-rabbit secondary antibodies. The anti-rabbit secondary antibody should not bind to the mouse derived primary, and thus the proximity probes should not be co-localized and the full docking site will not be available to bind the imager strand.

[00192] As shown in Figure 10 the microtubule structures are apparent only when both proximity probes are specifically bound to the target. Fluorescence signal is stable for standard fluorescence imaging.

#### **Example 5: Control experiment for off-target crossreactivity**

[00193] Cross-reactivity between off-target imager and docking strands was assessed by measuring the signal intensity of a sample before and after exposure to noncomplementary imager strand sequences.

[00194] Cultured HeLa cells were fixed, reduced, blocked and permeabilized, then stained with a mouse primary antibody against alpha-tubulin. Fixation buffer was composed of 3% paraformaldehyde and 0.1% glutaraldehyde. A solution containing 0.1% sodium borohydride was used to reduce fixed cells. A solution with 3% bovine serum albumin and 0.2% Triton-X 100 was used to block and permeabilized cells for 1.5 hours, prior to overnight primary antibody staining. To test the crossreactivity of docking strand *A* to imager strands *B* and *C*, anti-mouse antibodies conjugated to docking strand *A* (a-Ms-*A<sub>d</sub>*) were added to fixed cell

samples stained for alpha-tubulin. Secondary staining with  $\alpha$ -Ms- $A_d$  was done for 2 hours at room temperature in blocking buffer, then washed three times in 1x PBS. DAPI stain was added to all wells, and blank images were taken in both the DAPI and Cy5 channels on a Nikon fluorescence microscope with a 20x objective.

[00195] After recording blank images, imager strand solutions were prepared. In this example, an imager strand was partially double stranded; the imager strand was composed of a universal domain and a non-universal domain, where the universal domain is hybridized a complementary sequence that is attached to a fluorophore and the non-universal domain is single stranded and available to interact with a docking strand in a sample. In this example, a fluorophore is included in the imager strand indirectly, through a DNA-based bridge. In this example, the non-universal domain in an imager strand is complementary to a specific docking strand (ex. docking strand  $A$ ,  $B$ , or  $C$ .)

[00196] A 100 nM solution of imager strands  $A$  ( $A_i$ ),  $B$  ( $B_i$ ), or  $C$  ( $C_i$ ) was added to separate sample wells and allowed to hybridize for 10 minutes. Following hybridization of the imager strands, samples were washed with 1x PBS three times. Images were taken of each well in both the DAPI and Cy5 channels on a Nikon fluorescence microscope with a 20x objective. The same field of view was imaged as selected for the blank image previously.

[00197] The signal intensity of each sample was compared before and after addition of the imager strand using custom made software. Images were aligned using the DAPI channel, and a mask was made to segment individual cells from the background. The mean fluorescence intensity inside the cell region was calculated for the Cy5 channel and divided by the mean intensity of the background to yield a signal-to-noise ratio. The signal-to-noise ratios obtained in the blank image were compared to the signal-to-noise ratios obtained post-addition of imager strand to assess cross-reactivity between imager strands  $A_i$ ,  $B_i$ , and  $C_i$  with docking strand  $A$ .

[00198] As shown in Figure 11, the on-target imager strand  $A_i$  clearly shows the specific microtubule structures stained with  $\alpha$ -Ms- $A_d$ . Figure 11 also shows that  $B_i$  does not crossreact with docking strand  $A$ , but  $C_i$  does.

#### **Example 6: USER and subUSER**

[00199] This example demonstrates the ability to extinguish signal from a target using enzymatic activity. In this example, the docking strand (D1) was conjugated to secondary antibodies goat anti-mouse. The imager strands I1U complementary to D1, were labeled with a fluorescent dye (ATTO647N). The imager strand I1U contained several uracil nucleobases that can be cleaved by specific enzymatic activity, destabilizing the duplex imager/docking strands, resulting in the removal of fluorescent signal.

[00200] Cultured HeLa cells were fixed with warm 3% paraformaldehyde and 0.1% glutaraldehyde, reduced with 0.1% sodium borohydride, blocked and permeabilized with 3% bovine serum albumin and 0.2% Triton-X 100 in 1x PBS for 1.5 hours. The cells were first stained with a primary antibody anti-tubulin raised in mouse, overnight at 4 °C. Secondary staining was performed using a goat secondary antibody against mouse conjugated to D1 for 2 hours at room temperature. DAPI was added to stain the cell nuclei.

[00201] Samples were loaded onto an inverted Nikon Eclipse Ti microscope (Nikon Instruments) with a fluorescence module and an Andor Zyla sCMOS camera. The microscope was equipped with two fluorescence filter sets to image DAPI and the fluorescently labeled imager strands (Cy5 channel).

[00202] A solution of 100 nM I1U was added to two separate samples and incubated for 15 minutes. The samples were then washed 3 times with 1x PBS, and imaged using a 20x dry objective (Nikon, 0.45 NA), in both DAPI and Cy5 channels (Figure 12, Image A and C). To extinguish the signal, a solution containing 2 units of USER™, 50 mM potassium acetate, 20 mM tris-acetate, 10 mM magnesium acetate, and 100  $\mu$ g/ml BSA, was added to one sample. To the other sample, a solution of 10 units Uracil-DNA Glycosylase (UDG) in 20 mM Tris-HCl, 1 mM

DTT, 1 mM EDTA. Both samples were incubated at room temperature for 15 minutes. The samples were then washed 3 times with PBS 1x, and imaged (Figure 12, Image B for USER and D for UDG).

[00203] As shown on Figure 12, signal can be almost completely extinguished either using USER or UDG.

#### **Example 7: Cleavage of Imager Strands by USER**

[00204] As shown in Figure 14, the extent that signal can be extinguished may depend on the imager strand architecture and/or sequence design. In this example, formalin-fixed paraffin embedded (FFPE) tissue samples were dewaxed, antigen retrieved, blocked, and stained with anti-CD3 antibodies conjugated to docking strand D1. The number of D1 docking strands bound to the sample were amplified by RCA and labeled with imager strands containing a domain complementary to D1 and linked to a fluorophore. Imager strands either contained several uracil nucleobases (Figure 14A and C) or several uracil nucleobases and an abasic site (Figure 14B and D). Images were collected using a fluorescence microscope to detect the presence of targets bound by labeled imager strands (Figure 14A-B).

[00205] To extinguish the signal, a solution containing USER was added and incubated with the tissue sample for 15 minutes, followed by washing steps to remove the cleaved imager strands. Fluorescence images were collected to confirm the removal of the fluorescence signal. As shown in Figure 14D, the presence of an abasic site in addition to dideoxyuridines in the imager strand sequence design results in improved removal efficiency compared with Figure 14C.

#### **Example 8: Combined multicolor and sequential detection**

[00206] This example illustrates the ability to use Exchange Imaging to detect multiple targets using sets of imager strands functionalized with different, spectrally separated fluorophores.

[00207] Formalin-fixed paraffin-embedded (FFPE) tonsil tissue samples were dewaxed, antigen retrieved, blocked, and stained with DAPI, as well as anti-

CD4, anti-CD8, anti-Ki67, and anti-Cytokeratin antibodies respectively conjugated to docking strand D1, D2, D3, and D4. The number of docking strands (D1, D2, D3, D4) bound to the sample *via* the antibodies was amplified by RCA. Imager strands I1, I2, I3, and I4, containing a domain complementary to D1, D2, D3, and D4 respectively, also comprised several uracil bases for enzymatic removal. I1, and I3 are labeled with Atto565 dye, while I2 and I4 are labeled with Atto647N. Samples were imaged using an inverted Nikon Eclipse Ti microscope (Nikon Instruments) with a fluorescence module and an Andor Zyla sCMOS camera. The microscope was equipped with fluorescence filter sets to image DAPI and the fluorescently labeled imager strands (TRITC and Cy5 channels).

[00208] In a first step, the sample was labeled using I1 and I2 imager strands, by incubating a cocktail of the two strands on the sample for 25 minutes. The unbound strands were washed away, and images were collected in the TRITC and Cy5 channels to detect the presence of the targets labeled with the imager strands I1 and I2, respectively CD4 and CD8 (Figure 15 B and C respectively). A DAPI image was also collected to detect the cell nuclei (Figure 15 A).

[00209] The signal was then extinguished, using a solution containing USER, which was incubated with the tissue sample for 15 minutes, followed by washing steps to remove the cleaved imager strands. Fluorescence images were collected to confirm the removal of the fluorescence signal.

[00210] Finally, the sample was labeled again using a cocktail solution of the imager strands I3 and I4, followed by a wash step to remove unbound imager strands. A fluorescence image was acquired in the TRITC and Cy5 channels to detect the presence of Ki67 and Cytokeratin (Figure 15 E and F respectively). A DAPI image was also collected (Figure 15 D), and used to align and overlay the images of the four targets.

### **Example 9: Numbered Items**

[00211] The following numbered items provide a further description of the embodiments herein and how they relate to each other.

[00212] Item 1. A method comprising

(1) contacting a sample being tested for the presence of one or more targets with one or more target-specific binding partners, wherein each target-specific binding partner is linked to a nucleic acid strand and wherein target-specific binding partners of different specificity are linked to different nucleic acid strands,

(2) optionally removing unbound target-specific binding partners,

(3) wherein the nucleic acid strand is a docking strand or a primer strand and if the nucleic acid is

(a) a docking strand, increasing the number of docking strands associated with each target-specific binding partner, or

(b) a primer strand, associating more than one docking strand with the primer strand,

(4) contacting the sample with labeled imager strands capable of binding a docking strand, directly or indirectly,

(5) optionally removing unbound labeled imager strands,

(6) imaging the sample to detect bound labeled imager strands,

(7) optionally removing the bound labeled imager strands from the docking strands, and

(8) optionally repeating steps (1)-(6), or any subset thereof.

[00213] Item 2. A method comprising

(1) contacting a sample being tested for the presence of one or more targets with one or more target-specific binding partners, wherein each target-specific binding partner is linked to a nucleic acid strand and wherein target-specific binding partners of different specificity are linked to different nucleic acid strands,

(2) optionally removing unbound target-specific binding partners,

(3) contacting the sample with labeled imager strands capable of binding a docking strand, directly or indirectly, wherein the nucleic acid strand in (1) is

- either a primer strand or a docking strand and if the nucleic acid strand is a primer strand, it is linked to a docking strand,
- (4) optionally removing unbound labeled imager strands,
  - (5) imaging the sample to detect bound labeled imager strands and determine if amplification (step (7)) is required,
  - (6) optionally removing the bound labeled imager strands from the docking strands,
  - (7) optionally increasing the number of docking strands associated with each target-specific binding partner, and
  - (8) optionally repeating steps (1)-(7), or any subset thereof.

[00214] Item 3. A method to test a sample for the presence of one or more targets comprising

- (1) contacting a sample being tested for the presence of one or more targets with one or more target-specific binding partners, wherein each target-specific binding partner is linked to a nucleic acid strand and wherein target-specific binding partners of different specificity are linked to different nucleic acid strands,
- (2) optionally removing unbound target-specific binding partners,
- (3) contacting the sample with a nonlinear amplifier strand having complementarity to a nucleic acid strand, wherein the nucleic acid strand is either a docking strand or a primer strand,
- (4) optionally removing unbound nonlinear amplifier strands,
- (5) in either one or two steps amplifying the docking strand with rolling circle amplification and contacting the sample with labeled imager strands having complementarity to the docking strand or amplified strand,
- (6) imaging the sample to detect bound labeled imager strands,
- (7) removing the bound labeled imager strands, and
- (8) optionally repeating steps (1)-(8), or any subset thereof.

[00215] Item 4. The method of item 3, wherein a polymerase is used for rolling circle amplification.

[00216] Item 5. The method of any one of items 3-4, wherein the nonlinear amplifier strand is combined with the target-specific binding partner linked to a nucleic acid strand before contacting the sample.

[00217] Item 6. The method of any one of items 3-5, wherein amplifying the docking strand with rolling circle amplification occurs separately from contacting the sample with labeled imager strands having complementarity to the docking strand or amplified strand.

[00218] Item 7. The method of any one of items 3-6, wherein amplifying the docking strand with rolling circle amplification occurs in the same step as contacting the sample with labeled imager strands having complementarity to the docking strand and wherein the imager strand optionally comprises a 3' modification to prevent amplification of the imager strand.

[00219] Item 8. The method of any one of items 3-5 or 7, wherein the imager strand is a circular imager strand for rolling circle amplification.

[00220] Item 9. The method of any one of items 3-7, wherein the imager strand is a linear imager strand that circularizes in the presence of the docking strand and a ligase.

[00221] Item 10. The method of any one of items 3-9, wherein the imager strand or amplifier strand comprises at least two regions that are complementary to the docking strand.

[00222] Item 11. The method of any one of items 3-10, wherein the labeled imager strands are linear strands.

[00223] Item 12. The method of any one of items 3-11, wherein the nonlinear amplifier strand is a circular strand.

[00224] Item 13. The method of any one of items 3-12, wherein the nonlinear amplifier strand becomes circular after ligation.

[00225] Item 14. A method to test a sample for the presence of one or more targets comprising

(1) contacting the sample with one or more target-specific binding partners, wherein each target-specific binding partner is linked to a nucleic acid strand, directly or indirectly, and wherein target-specific binding partners of different specificity are linked to different nucleic acid strands,

(2) optionally removing unbound target-specific binding partners,

(3) wherein the nucleic acid strand is a docking strand or a primer strand and if the nucleic acid is

(a) a docking strand, optionally increasing the number of docking strands associated with each target-specific binding partner, or

(b) a primer strand, optionally associating more than one docking strand with the primer strand,

(4) contacting the sample with labeled imager strands capable of binding a docking strand, directly or indirectly,

(5) optionally removing unbound labeled imager strands,

(6) imaging the sample to detect bound labeled imager strands, and

(7) optionally extinguishing signal from the bound labeled imager strand;

(8) optionally repeating steps (1)-(7) or any subset thereof.

[00226] Item 15. The method of item 14, wherein the sample is mounted to an optically transparent support.

[00227] Item 16. The method of any one of items 14-15, wherein after step (6) and after optionally performing step (7) the method further comprises increasing the number of docking strands associated with each target-specific binding partner and repeating steps (4), optionally (5), (6), and optionally (7).

[00228] Item 17. The method of any one of items item 14-16, wherein the method comprises at step (3) increasing the number of docking strands associated with each target-specific binding partner or associating more than one docking strand with the primer strand.

[00229] Item 18. The method of any one of items 1-17, where the increase in the number of docking strands associated with each target-specific binding partner is achieved using an enzyme and wherein the enzyme is optionally a polymerase.

[00230] Item 19. The method of any one of items 1-18, wherein enzymatically cleaving, modifying, or degrading unbound labeled imager strands is achieved by using an enzyme and wherein the enzyme is optionally a glycosylase, a restriction endonuclease, a nicking endonuclease, an RNase, and an enzyme that cleaves at a non-natural nucleotide.

[00231] Item 20. A method to test a sample mounted to an optically transparent support for the presence of one or more targets comprising

(1) contacting the sample with one or more target-specific binding partners, wherein each target-specific binding partner is linked to a nucleic acid strand, and wherein target-specific binding partners of different specificity are linked to different nucleic acid strands,

(2) optionally removing unbound target-specific binding partners,

(3) wherein the nucleic acid strand is a docking strand or a primer strand and optionally if the nucleic acid is

(a) a docking strand, increasing the number of docking strands associated with each target-specific binding partner, or

(b) a primer strand, associating more than one docking strand with the primer strand,

(4) contacting the sample with labeled imager strands capable of binding a docking strand, directly or indirectly,

(5) optionally removing unbound labeled imager strands,

(6) optionally removing liquid to create a liquid-free sample,

(7) affixing a second optically-transparent material parallel to the first support, and

(8) imaging the sample to detect bound labeled imager strands.

[00232] Item 21. The method of item 20, where the second optically-transparent material is glass.

[00233] Item 22. The method of item 21, where the second optically-transparent material is plastic.

[00234] Item 23. The method of any one of items 20-22, wherein the second optically-transparent material is 5 microns to 5 mm, from 50 microns to 500 microns, or from 500 microns to 5 mm from the first support.

[00235] Item 24. The method of item 20, where the imaging is carried out with an upright microscope.

[00236] Item 25. A method to test a fixed sample mounted to an optically transparent support for the presence of one or more targets comprising

- (1) contacting the sample with one or more target-specific binding partners, wherein each target-specific binding partner is linked to a nucleic acid strand and wherein target-specific binding partners of different specificity are linked to different nucleic acid strands,
- (2) optionally removing unbound target-specific binding partners,
- (3) wherein the nucleic acid strand is a docking strand or a primer strand and if the nucleic acid is
  - (a) a docking strand, increasing the number of docking strands associated with each target-specific binding partner, or
  - (b) a primer strand, associating more than one docking strand with the primer strand,
- (4) contacting the sample with labeled imager strands capable of binding a docking strand, directly or indirectly,
- (5) optionally removing unbound labeled imager strands,
- (6) optionally removing liquid to create a liquid-free sample,
- (7) affixing a second optically-transparent material parallel to the first support, and
- (8) imaging the sample to detect bound labeled imager strands.

- [00237] Item 26. A method comprising
- (1) contacting a sample being tested for the presence of one or more targets with one or more target-specific binding partners, wherein each target-specific binding partner is linked to a nucleic acid strand and wherein target-specific binding partners of different specificity are linked to different nucleic acid strands,
  - (2) optionally removing unbound target-specific binding partners,
  - (3) wherein the nucleic acid strand is a docking strand or a primer strand and optionally if the nucleic acid is
    - (a) a docking strand, increasing the number of docking strands associated with each target-specific binding partner, or
    - (b) a primer strand, associating more than one docking strand with the primer strand,
  - (4) contacting the sample with labeled imager strands capable of binding a docking strand, directly or indirectly,
  - (5) optionally removing unbound labeled imager strands,
  - (6) imaging the sample to detect presence, location and number of bound labeled imager strands,
  - (7) extinguishing signal from the bound labeled imager strand, and
  - (8) repeating steps (3)-(6) or (3)-(7), with a labeled imager strand optionally having a unique nucleotide sequence relative to all other labeled imager strands.

- [00238] Item 27. A composition comprising:  
a sample bound to more than one target-specific binding partners, each binding partner bound to a nucleic acid strand and at least one docking strand stably bound to a labeled imager strand, directly or indirectly, wherein the nucleic acid strand is a docking strand or a primer strand if the nucleic acid is
  - (a) a docking strand, increasing the number of docking strands associated with each target-specific binding partner, or

(b) a primer strand, associating more than one docking strand with the primer strand.

[00239] Item 28. The composition of item 27, wherein the docking strand bound to a labeled imager strand, directly or indirectly, comprises at least 90% binding for 30 minutes.

[00240] Item 29. The composition of any one of items 27-28, wherein the

(a) docking strand or

(b) docking strand and any intermediate strand

is 80 nucleotides or less, 70, 60, 50, 40, or 30 nucleotides or less.

[00241] Item 30. The composition of any one of items 27-29, wherein the imager strand is 60 nucleotides or less.

[00242] Item 31. A composition comprising:

(a) a composition employing a half-docking domain, wherein the composition comprises (i) at least one first binding partner-oligonucleotide conjugate comprising a binding partner linked to an oligonucleotide that comprises a half-docking domain, an optional stability domain, and optionally a spacer domain; (ii) at least one second binding partner-oligonucleotide conjugate comprising a binding partner linked to an oligonucleotide that comprises a half-docking domain, an optional stability domain, and optionally a spacer domain; wherein the stability domains of (a)(i) and (a)(ii) are complementary to each other, and wherein the half-docking domains of (a)(i) and (a)(ii) combine linearly to form a full docking domain; and (iii) at least one labeled imager strand or intermediate strand comprising a 5' domain, a 3' domain, and a linker domain located between the 5' domain and the 3' domain, wherein the 5' domain is complementary to the half-docking domain of (a)(i) and the 3' domain is complementary to the half-docking domain of (a)(ii), and wherein the labeled imager or intermediate strand is stably bound to the full docking domain and if an intermediate strand is used also providing a labeled imager strand; or

(b) a composition employing a half-primer domain, wherein the composition comprises (i) at least one first binding partner-oligonucleotide conjugate comprising a binding partner linked to an oligonucleotide that comprises a half-primer domain, an optional stability domain, and optionally a spacer domain; (ii) at least one second binding partner-oligonucleotide conjugate comprising a binding partner linked to an oligonucleotide that comprises a half-primer domain, an optional stability domain, and optionally a spacer domain; wherein the stability domains of (b)(i) and (b)(ii) are complementary to each other, and wherein the half-primer domains of (b)(i) and (b)(ii) can combine linearly to form a full primer domain; (iii) at least one docking strand capable of being stably bound to the full primer domain; and (iv) at least one labeled imager strand capable of being stably bound to the docking strand or an intermediate strand capable of being stably bound to the docking strand and a labeled imager strand capable of being stably bound to the intermediate strand.

[00243] Item 32. The composition of item 31, wherein at least one imager strand is bound to a full docking domain for at least 30 minutes.

[00244] Item 33. The composition of item 31, wherein at least 70% of imager strands bound to full docking domains remain bound for at least 30 minutes.

[00245] Item 34. The composition of item 31, wherein at least 90% of imager strands bound to full docking domains are resistant to non-enzymatic buffer washes.

[00246] Item 35. A method to test a fixed sample mounted to an optically transparent support for the presence of one or more targets comprising

- (1) contacting the sample with one or more target-specific binding partners, wherein each target-specific binding partner is linked to a nucleic acid strand and wherein target-specific binding partners of different specificity are linked to different nucleic acid strands,
- (2) optionally removing unbound target-specific binding partners,
- (3) wherein the nucleic acid strand is a docking strand or a primer strand and optionally if the nucleic acid is

- (a) a docking strand, increasing the number of docking strands associated with each target-specific binding partner, or
- (b) a primer strand, associating more than one docking strand with the primer strand,
- (4) contacting the sample with labeled imager strands capable of binding a docking strand, directly or indirectly, wherein when used indirect binding is capable of occurring through an intermediate strand,
- (5) optionally removing unbound labeled imager strands,
- (6) imaging the sample to detect bound labeled imager strands,
- (7) extinguishing signal from the bound labeled imager strand,
- (8) contacting the sample with labeled imager strands having a nucleotide sequence that is not complementary to a docking strand or, when used, an intermediate strand,
- (9) optionally removing unbound labeled imager strands,
- (10) imaging the sample to detect bound labeled imager strands, and
- (11) optionally extinguishing signal from the bound labeled imager strand.

[00247] Item 36. A method to test a fixed sample mounted to an optically transparent support for the presence of one or more targets comprising

- (1) contacting the sample with one or more target-specific binding partners, wherein each target-specific binding partner is linked to a nucleic acid strand, and wherein target-specific binding partners of different specificity are linked to different nucleic acid strands,
- (2) optionally removing unbound target-specific binding partners,
- (3) wherein the nucleic acid strand is a docking strand or a primer strand and optionally if the nucleic acid is
  - (a) a docking strand, increasing the number of docking strands associated with each target-specific binding partner, or
  - (b) a primer strand, associating more than one docking strand with the primer strand,

- (4) contacting the sample with labeled imager strands having a nucleotide sequence that is not complementary to a docking strand or, when used, any intermediate strand,
- (5) optionally removing unbound labeled imager strands,
- (6) imaging the sample to detect presence, location and/or number of bound labeled imager strands,
- (7) extinguishing signal from the bound labeled imager strand.
- (8) contacting the sample with labeled imager strands capable of binding a docking strand, directly or indirectly, wherein, when used, indirect binding is capable of occurring through an intermediate strand,
- (9) optionally removing unbound labeled imager strands,
- (10) imaging the sample to detect presence, location, and/or number of bound labeled imager strands, and
- (11) optionally extinguishing signal from the bound labeled imager strand.

[00248] Item 37. The method of either one of items 35 or 36, wherein the method further comprises repeating steps (4)-(11).

[00249] Item 38. The method of either one of items 35-37, wherein the method further comprises repeating steps to detect binding of additional noncomplementary imaging strands.

[00250] Item 39. The method of any one of items 35-38, wherein the labeled imager strands capable of binding a docking strand, directly or indirectly, used in the repeated steps optionally has a unique nucleotide sequence relative to at least one other labeled imager strands capable of binding another docking strand, directly or indirectly.

[00251] Item 40. A composition comprising

- (1) a label,
- (2) a first nucleic acid domain, a second nucleic acid domain, and a third nucleic acid domain, wherein each nucleic acid domain is from 1 to 9 nucleotides long,

(3) a first linking moiety linking the first nucleic acid domain and the second nucleic acid domain and

(4) a second linking moiety linking the second nucleic acid domain and the third nucleic acid domain,

wherein both linking moieties are independently chosen from (a) an abasic site with an intact phosphodiester backbone, (b) a linker cleavable by a nucleic acid glycosylase, (c) non-natural nucleotides, or (d) restriction site or a nicking site.

[00252] Item 41. The composition of item 40, wherein additional nucleic acid domains are linked by additional linking moieties.

[00253] Item 42. The composition of any one of items 40-41, wherein at least one linking moiety is an abasic site (apyrimidinic) with an intact phosphodiester backbone.

[00254] Item 43. The composition of any one of items 40-42, wherein at least one linking moiety is susceptible to cleavage from Endonuclease VIII.

[00255] Item 44. The composition of any one of items 40-43, wherein the nucleic acid domains comprise DNA.

[00256] Item 45. The composition of any one of items 40-44, wherein the nucleic acid domains comprise RNA.

[00257] Item 46. The composition of any one of items 40-45, wherein at least one linking moiety comprises at least one non-natural nucleotide.

[00258] Item 47. The composition of any one of items 40-46, wherein at least one linking moiety comprises 8-oxoguanine.

[00259] Item 48. A method to test a sample for the presence of one or more targets comprising

(1) contacting the sample with one or more target-specific binding partners, wherein each target-specific binding partner is linked to a nucleic acid strand, directly or indirectly and wherein target-specific binding partners of different specificity are linked to different nucleic acid strands,

- (2) optionally removing unbound target-specific binding partners,
- (3) wherein the nucleic acid strand is a docking strand or a primer strand and if the nucleic acid is
  - (a) a docking strand, increasing the number of docking strands associated with each target-specific binding partner, or
  - (b) a primer strand, associating more than one docking strand with the primer strand,
- (4) contacting the sample with labeled imager strands capable of binding a docking strand, directly or indirectly, wherein the labeled imager strands comprise the composition of any one of items 34-41,
- (5) optionally removing unbound labeled imager strands,
- (6) imaging the sample to detect bound labeled imager strands,
- (7) removing the bound labeled imager strands from the docking strands, wherein the labeled imager strands are removed from the docking strands by enzymatically cleaving, modifying, or degrading the labeled imager nucleic acids,
- (8) optionally repeating steps (1)-(7), or any subset thereof.

[00260] Item 49. The method of item 48, wherein the labeled imager nucleic acids are removed by enzymatically cleaving the labeled imager strand.

[00261] Item 50. A method to test a sample for the presence of one or more targets comprising

- (1) treating the sample to expose one or more previously unavailable targets,
- (2) contacting the sample with one or more target-specific binding partners, wherein each target-specific binding partner is linked to a nucleic acid strand and wherein target-specific binding partners of different specificity are linked to different nucleic acid strands,
- (3) optionally removing unbound target-specific binding partners,
- (4) wherein the nucleic acid strand is a docking strand or a primer strand and optionally if the nucleic acid is

- (a) a docking strand, increasing the number of docking strands associated with each target-specific binding partner, or
- (b) a primer strand, associating more than one docking strand with the primer strand,
- (5) contacting the sample with labeled imager strands capable of binding a docking strand, directly or indirectly,
- (6) optionally removing unbound labeled imager strands,
- (7) imaging the sample to detect bound labeled imager strands,
- (8) extinguishing signal from the bound labeled imager strand, and
- (9) optionally repeating steps (1)-(8), each time (a) exposing a different set of previously unavailable targets (b) using one or more different target-specific binding partners and (c) using a labeled imager strand having a unique nucleotide sequence relative to at least one other labeled imager strand.

[00262] Item 51. A method to test a fixed sample mounted to a first optically transparent support for the presence of one or more targets comprising

- (1) contacting the sample with one or more target-specific binding partners, wherein each target-specific binding partner is linked to a nucleic acid strand and wherein target-specific binding partners of different specificity are linked to different nucleic acid strands,
- (2) optionally removing unbound target-specific binding partners,
- (3) wherein the nucleic acid strand is a docking strand or a primer strand and optionally if the nucleic acid is

- (a) a docking strand, increasing the number of docking strands associated with each target-specific binding partner, or
- (b) a primer strand, associating more than one docking strand with the primer strand,
- (4) in an imaging chamber (such as a flow cell), contacting the sample with labeled imager strands capable of binding a docking strand, directly or indirectly,

- (5) optionally removing unbound labeled imager strands,
- (6) imaging the sample to detect presence, location, and/or number of bound labeled imager strands,
- (7) extinguishing signal from the bound labeled imager strand, and
- (8) repeating steps (4)-(6) or (4)-(7), at least once with a labeled imager strand optionally having a unique nucleotide sequence relative to at least one other labeled imager strands.

[00263] Item 52. The method of item 51, wherein the imaging chamber is removed after an imaging step and before repeating steps (4)-(6) or (4)-(7).

[00264] Item 53. The method of any one of items 51-52, wherein the imaging chamber does not permit fluid flow and the imaging chamber is removed after an imaging step and before repeating steps (4)-(6) or (4)-(7).

[00265] Item 54. The method of any one of items 51-53, where the flow cell is formed with a second optically-transparent material.

[00266] Item 55. The method of item 54, where the second optically-transparent material comprises glass.

[00267] Item 56. The method of item 54, where the second optically-transparent material comprises plastic.

[00268] Item 57. The method of any one of items 51-52, wherein the imaging chamber (such as a flow cell) comprises a gasket with at least one fluid inlet and/or outlet ports.

[00269] Item 58. The method of any one of items 54-56, wherein the flow cell comprises a second optically-transparent material parallel to the first optically-transparent support.

[00270] Item 59. The method of any one of items 1-26, 35-39, or 48-58, wherein all fluidic exchange steps are performed using a fluidic system comprising electronic, and/or pneumatic, and/or hydraulic, and/or electro-fluidic actuators and systems.

[00271] Item 60. The method of item 59, wherein the fluidic system is controlled by software.

[00272] Item 61. The method of item 59, wherein the fluidic system is automatically controlled by software synchronizing steps (1 and/or 2 and/or 3 and/or 4 and/or 5, and/or 7) with the imaging step (6), with reference to the numbering provided in item 1.

[00273] Item 62. The method of item 59, wherein the fluidic system is controlled by software synchronizing the steps (1 and/or 2 and/or 3 and/or 4 and/or 5, and/or 7) with the imaging step (6) by communicating with the imaging software, with reference to the numbering provided in item 1.

[00274] Item 63. The method of any one of items 59-62, wherein all fluidic steps are performed while the sample is on the imaging device.

[00275] Item 64. The method of any one of items 59-63, wherein steps 4, 5, and 7 are performed while the sample is on the imaging device, with reference to the numbering provided in item 1.

[00276] Item 65. The method of any one of items 59-64, wherein the sample is fixed in a disposable imaging chamber (such as a flow cell).

[00277] Item 66. The method of any one of items 59-65, wherein the sample is fixed in a reusable imaging chamber (such as a flow cell).

[00278] Item 67. A kit comprising:

(1) one or more reagent(s) including but not limited to target-specific binding partners linked to nucleic acid strands, wherein target-specific binding partners of different specificity are linked to different nucleic acid strands, labeled imager strands, buffers, amplification reagents, and/or reagents to remove bound imager strands, wherein the nucleic acid strand is a docking strand or a primer strand and if the nucleic acid strand is a docking strand, increasing the number of docking strands associated with each target-specific binding partner, or if the nucleic acid is a primer strand, associating more than one docking strand with the primer strand,

(2) a fluidic system to perform all fluid exchange steps,  
a software to control the fluidic system and time and/or synchronize the  
fluidic steps with the imaging steps,

(3) a flow cell to affix on the sample of interest with at least one optically  
transparent side to allow imaging of the sample.

[00279] Item 68. The kit of item 67, wherein the flow cell is a disposable  
flow cell.

[00280] Item 69. The method of any one of items 1-26, 35-39, or 48-66,  
wherein imaging the sample to detect bound labeled imager strands detects the  
presence of bound labeled imager strands.

[00281] Item 70. The method of any one of items 1-26, 35-39, or 48-66,  
wherein imaging the sample to detect bound labeled imager strands detects the  
presence, location, and/or number of bound labeled imager strands.

[00282] Item 71. The method of any one of items 70, wherein the  
method comprises imaging the sample to detect and/or measure a background signal  
and subtracting the background signal from the image of the sample to detect bound  
labeled imager strands.

[00283] Item 72. The method of item 71, wherein the background signal  
comprises autofluorescence.

[00284] Item 73. The method of any one of items 71-72, wherein the  
background comprises residual fluorescence associated with incompletely  
extinguishing signal from the bound labeled imager strands.

[00285] Item 74. The method of any one of items 71-73, wherein the  
background signal is measured before the image of the sample to detect bound  
labeled imager strands.

[00286] Item 75. The method of any one of items 71-74, wherein the  
background signal is measured after the image of the sample to detect bound labeled  
imager strands.

[00287] Item 76. The method of any one of items 1-26, 35-39, or 48-75, wherein the sample is a fixed sample.

[00288] Item 77. The method of any one of items 1-26, 35-39, or 48-76, wherein the sample is a cell, cell lysate, tissue, tissue lysate, bodily fluid, and/or a whole organism.

[00289] Item 78. The method of any one of items 1-26, 35-39, or 48-77, wherein the method is useful for identifying a biomarker.

[00290] Item 79. The method of item 78, wherein at least 96 samples are imaged and data analysis performed on those samples.

[00291] Item 80. The method of any one of items 78-79, wherein at least 15 targets are tested for using corresponding target-specific binding partners for each target.

[00292] Item 81. The method of any one of items 1-26, 35-39, or 48-80, wherein the imaging is performed using a light microscope, fluorescence microscope including widefield, confocal (line and point scanning, spinning disk), total internal reflection (TIR), stimulated emission depletion (STED), light-sheet illumination, structured illumination (SIM), and expansion microscopy.

[00293] Item 82. The method of any one of items 1-26, 35-39, or 48-81, wherein the docking strand bound to a labeled imager strand, directly or indirectly, comprises at least 90% binding for 30 minutes.

[00294] Item 83. The method of any one of items 1-26, 35-39, or 48-82, wherein the target-specific binding partner is directly linked to a docking strand.

[00295] Item 84. The method of any one of items 1-26, 35-39, or 48-83, wherein the target-specific binding partner is indirectly linked to a docking strand through a primer strand.

[00296] Item 85. The method of any one of items 1-26, 35-39, or 48-84, wherein the docking strand binds the imager strand directly.

[00297] Item 86. The method of any one of items 1-26, 35-39, or 48-85, wherein the docking strand has complementarity to the imager strand.

[00298] Item 87. The method of any one of items 1-26, 35-39, or 48-86, wherein the docking strand binds the imager strand indirectly through an intermediate strand.

[00299] Item 88. The method of any one of items 1-26, 35-39, or 48-87 or the kit of items 67-68, wherein the imager strand and/or the intermediate strand comprises at least one U capable of cleavage by USER.

[00300] Item 89. The method of any one of items 1-26, 35-39, or 48-88 or the kit of items 66-67 and 88, wherein the imager strand and/or intermediate strand comprises at least one abasic site.

[00301] Item 90. The method of any one of items 1-25, 34-38, or 47-89 or the kit of items 66-67 and 89, wherein the imager strand and/or the intermediate strand comprise a hairpin.

[00302] Item 91. The method of any one of items 1-25, 34-38, or 47-90 or the kit of items 66-67 or 88-90, wherein the imager strand and/or the intermediate strand comprise a hairpin with a clamp.

[00303] Item 92. The method of any one of items 1-25, 34-38, or 47-91, wherein at least two targets are imaged using at least two labels in the same imaging step.

[00304] Item 93. The method of any one of items 1-25, 34-38, or 47-92, wherein at least two targets are imaged using the same label in different imaging steps.

[00305] Item 94. The method of any one of items 1-25, 34-38, or 47-93, wherein at least two targets are imaged using at least two labels, the signal extinguished, and then at least one more target is imaged using at least one of the same labels, wherein the imaging steps may be performed in either order.

[00306] Item 95. The method of any one of items 1-25, 34-38, or 47-93, wherein extinguishing the signal from the bound labeled imager strand comprises removing the nucleic acid strand from the target-specific binding partner.

[00307] Item 96. The method of item 95, wherein removing the nucleic acid strand comprises enzymatically cleaving, modifying, or degrading the nucleic acid strand linked to the target specific binding partner.

[00308] Item 97. The method of item 97, wherein the nucleic acid strand is docking strand.

[00309] Item 98. The method of item 97, wherein the nucleic acid strand is a primer strand.

[00310] Item 99. The method of any one of items 1-25, 34-38, or 47-94, wherein if the nucleic acid strand linked to the target specific binding partner is a primer strand, extinguishing the signal from the bound labeled imager strand comprises removing the docking strand from the primer strand.

[00311] Item 100. The method of item 99, wherein removing the docking strand comprises enzymatically cleaving, modifying, or degrading the docking strand.

[00312] Item 101. The method of any one of items 1-25, 34-38, or 47-94, wherein extinguishing the signal from the bound labeled imager strand comprises removing the imager strand.

[00313] Item 102. The method of any one of items 1-25, 34-38, or 47-94, wherein removing the imager strand comprises enzymatically cleaving, modifying, or degrading the imager strand.

[00314] Item 103. The method of any one of items 1-25, 34-38, or 47-94, wherein extinguishing the signal from the bound labeled imager strand comprises removing the label from the imager strand.

## EQUIVALENTS

[00315] The foregoing written specification is sufficient to enable one skilled in the art to practice the embodiments. The foregoing description and Examples detail certain embodiments and describes the best mode contemplated by the inventors. It will be appreciated, however, that no matter how detailed the

foregoing may appear in text, the embodiment may be practiced in many ways and should be construed in accordance with the appended claims and any equivalents thereof.

[00316] As used herein, the term about refers to a numeric value, including, for example, whole numbers, fractions, and percentages, whether or not explicitly indicated. The term about generally refers to a range of numerical values (e.g., +/-5-10% of the recited range) that one of ordinary skill in the art would consider equivalent to the recited value (e.g., having the same function or result). When terms such as at least and about precede a list of numerical values or ranges, the terms modify all of the values or ranges provided in the list. In some instances, the term about may include numerical values that are rounded to the nearest significant figure.

What is Claimed is:

1. A method to test a tissue sample for the location of two or more targets comprising:
  - (1) contacting a tissue sample being tested for the presence of two or more targets with two or more target-specific binding partners, wherein each target-specific binding partner is directly linked to a nucleic acid strand, wherein the nucleic acid strand is a docking strand, wherein target-specific binding partners of different specificity are linked to different docking strands, and wherein the sample is a tissue sample;
  - (2) optionally removing unbound target-specific binding partners,
  - (3) contacting the tissue sample with circular amplifier strands having complementarity to the different docking strands,
  - (4) optionally removing unbound circular amplifier strands,
  - (5) amplifying simultaneously the different docking strands with rolling circle amplification to produce amplified strands comprising concatemeric repeats of the different docking strands,
  - (6) contacting the tissue sample with labeled imager strands capable of binding directly, to the amplified strands, wherein each of the labeled imager strands comprise an imager strand with a different fluorescent label attached thereto ,
  - (7) imaging the tissue sample to detect the presence and location of bound labeled imager strands,
  - (8) extinguishing the signal from the bound labeled imager strands, and
  - (9) optionally repeating steps (1)-(8), or any subset thereof.
2. The method of claim 1, wherein the circular amplifier strands are combined with the target-specific binding partners linked to nucleic acid strands before contacting the sample.
3. The method of claim 1 or 2, wherein amplifying simultaneously the different docking strands with rolling circle amplification occurs separately from contacting the sample with labeled imager strands.
4. The method of claim 1 or 2, wherein amplifying simultaneously the different docking strands with rolling circle amplification occurs in the same step as contacting the sample with labeled imager strands.
5. The method of claim 4, wherein the imager strands comprise a 3' modification to prevent amplification of the imager strands.

6. The method of any one of claims 1-5, wherein the labeled imager strands are hybridized to the concatemeric repeats of the docking strands.
7. The method of any one of claims 1-6, wherein at least two targets are imaged using at least two labels, the signal extinguished, and then at least one more target is imaged, optionally wherein at least one of the same labels is used in each imaging step.
8. The method of any one of claims 1-5, wherein steps (6) – (9) or a subset thereof are repeated, optionally wherein steps (6) and (7) are repeated.
9. The method of any one of claims 1-8, wherein the extinguishing comprises a step selected from: removing the bound imager strands from the docking strands; removing the labels from the imager strands; inactivating the label on the imager strands; and enzymatically cleaving, modifying, or degrading the bound imager strands.
10. The method of claim 9, wherein the extinguishing is accomplished by a condition selected from high temperature, low ionic strength buffer, denaturant, strand displacement, chemical cleavage, photochemical cleavage, and enzymatic cleavage.
11. The method of claim 10, wherein enzymatic cleavage is performed optionally wherein the enzyme is selected from glycosylase, restriction endonuclease, nicking endonuclease, DNase, RNase, and an enzyme that cleaves at a non-natural nucleotide.
12. The method of any one of claims 1-11, wherein a target-specific binding partner is an antibody, optionally wherein the extinguishing comprises disrupting the link between the docking strand and the antibody.
13. The method of any one of claims 1-12, wherein the nucleic acid strands comprise DNA, and the imager strand comprises a complementary nucleotide sequence.
14. The method of any one of claims 1-13, wherein an imager strand comprises at least one deoxyuridine capable of cleavage by uracil-DNA-glycosylase.
15. The method of any one of claims 1-14, wherein an imager strand comprises an abasic site capable of cleavage by endonuclease, optionally wherein the endonuclease is Endonuclease VIII.

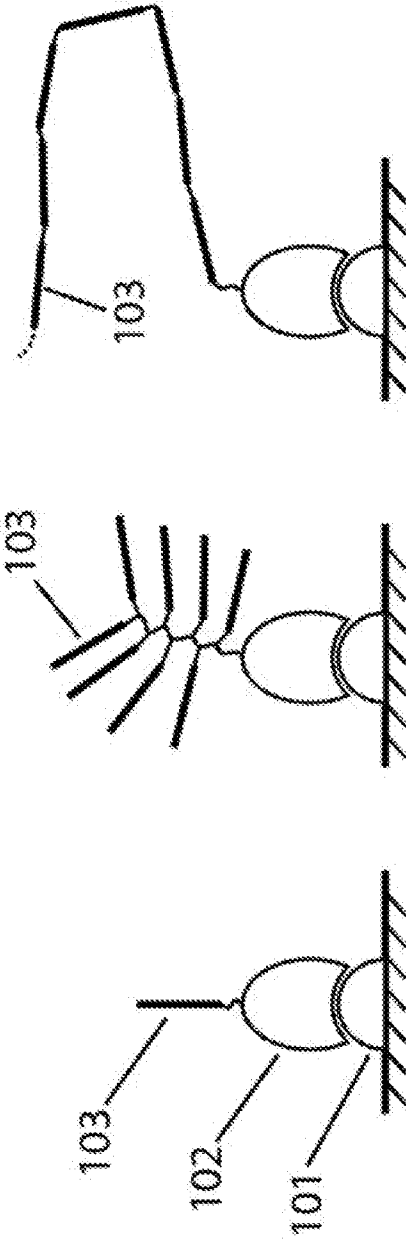

FIG. 1C

FIG. 1B

FIG. 1A

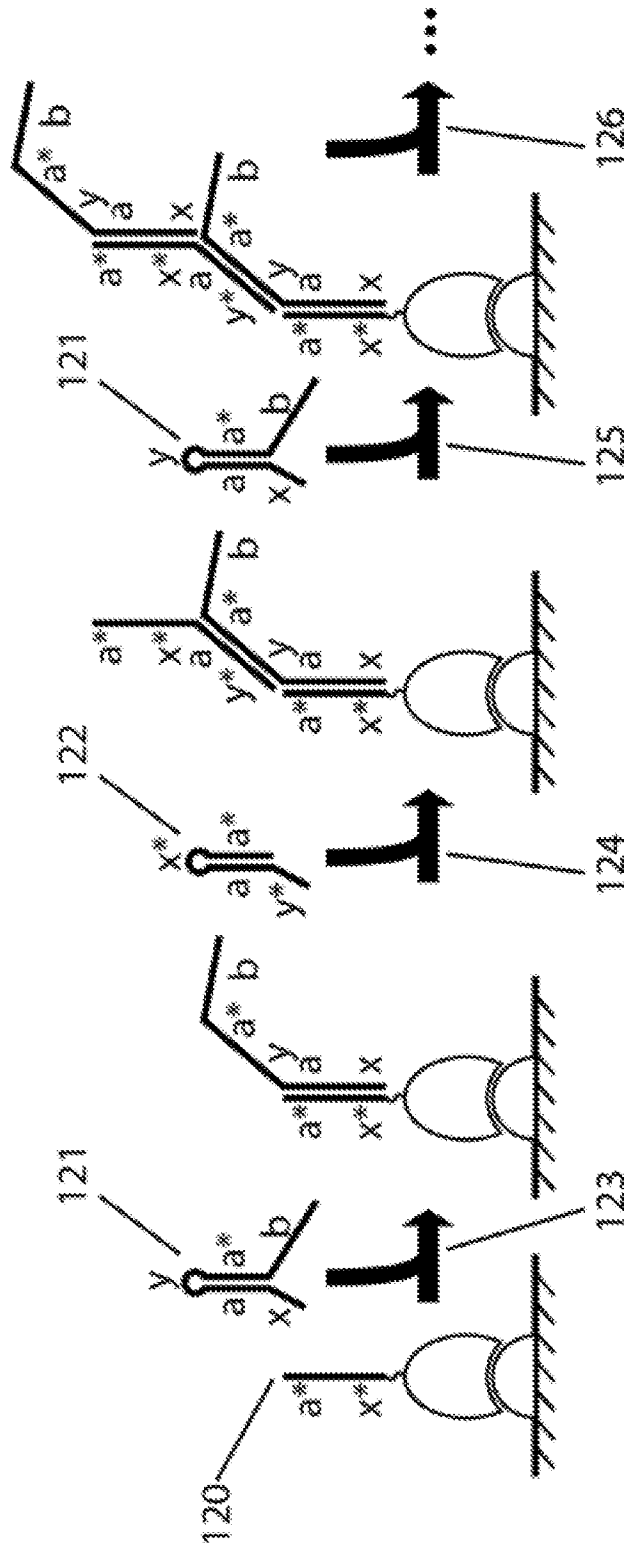

FIG. 1D

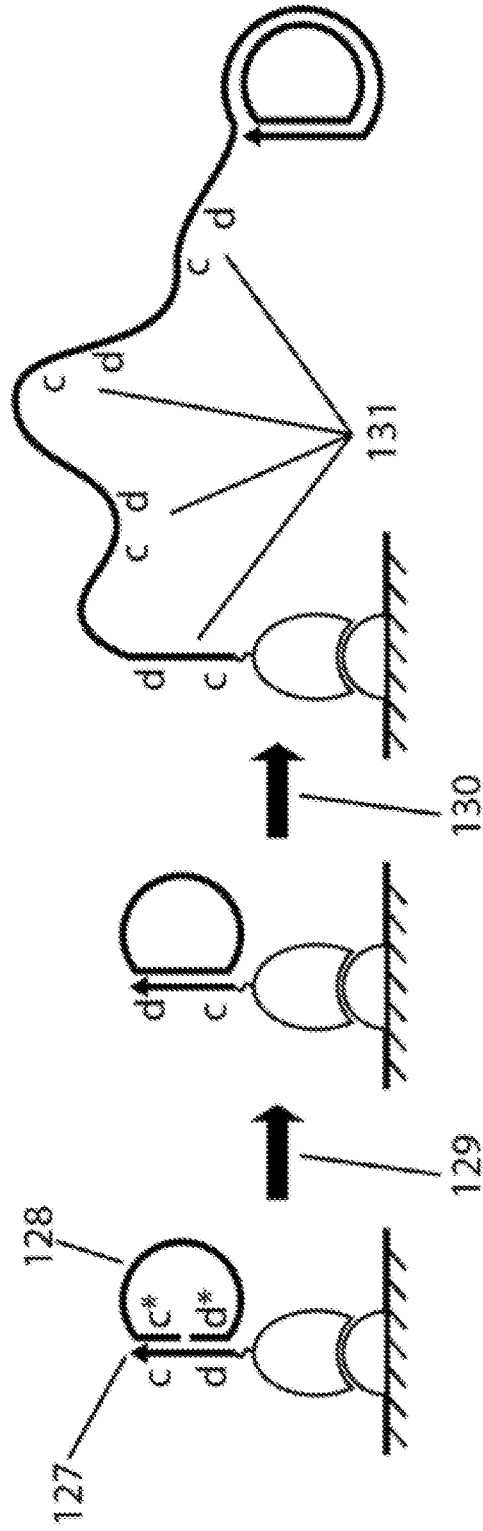

FIG. 1E

4/23

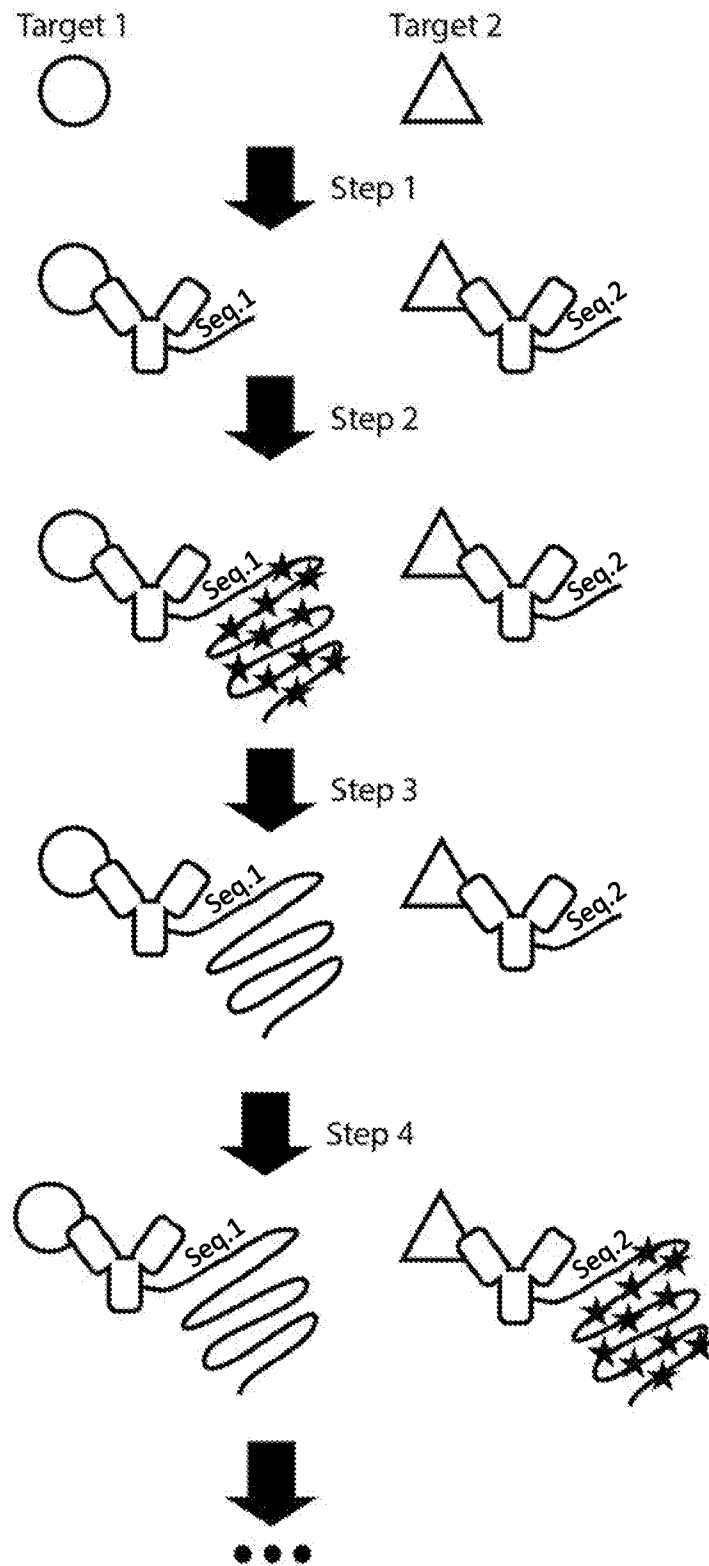

FIG. 2

5/23

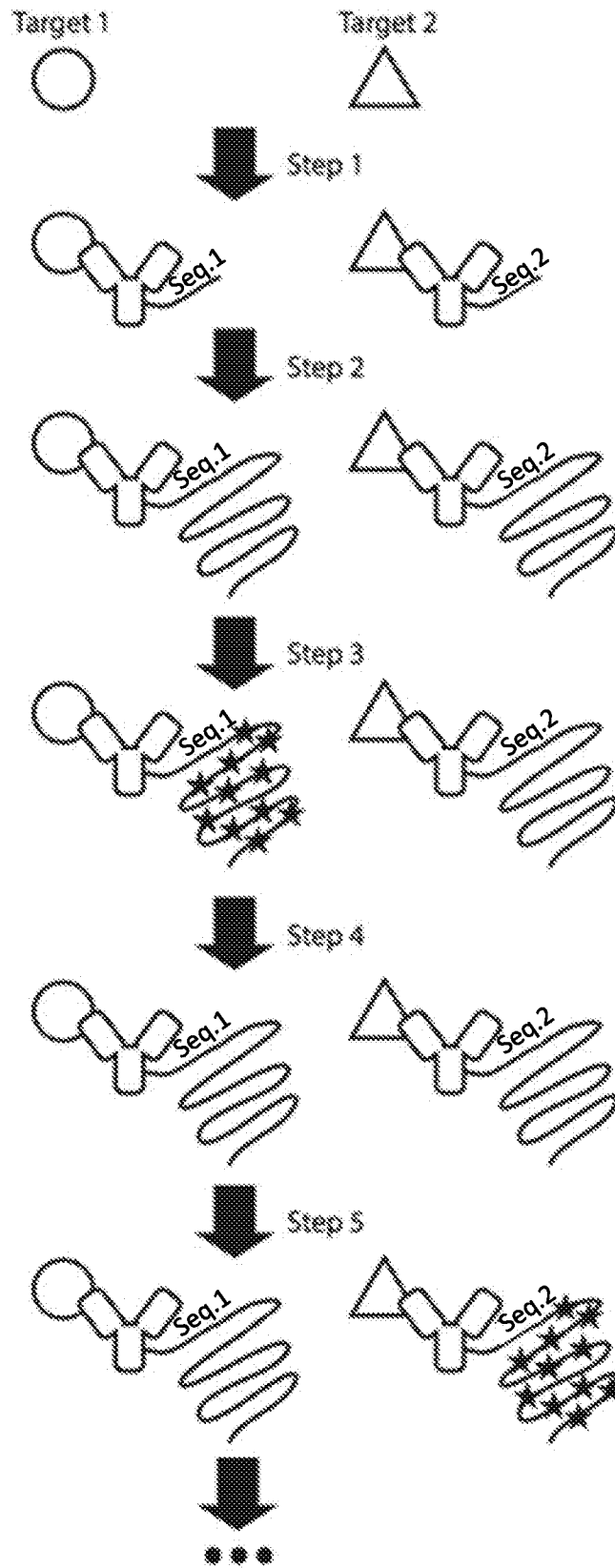

FIG. 3

6/23

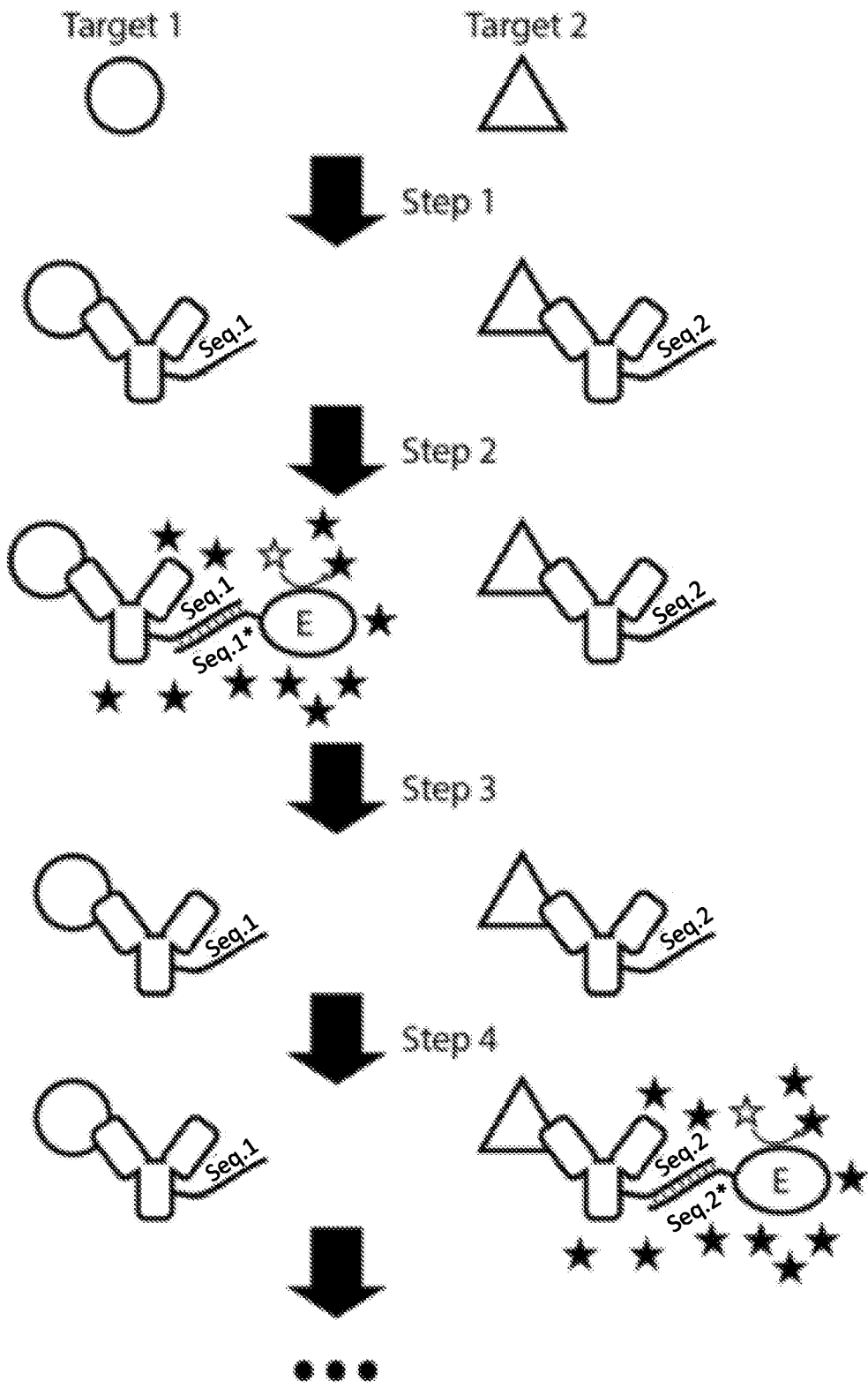

FIG. 4A

7/23

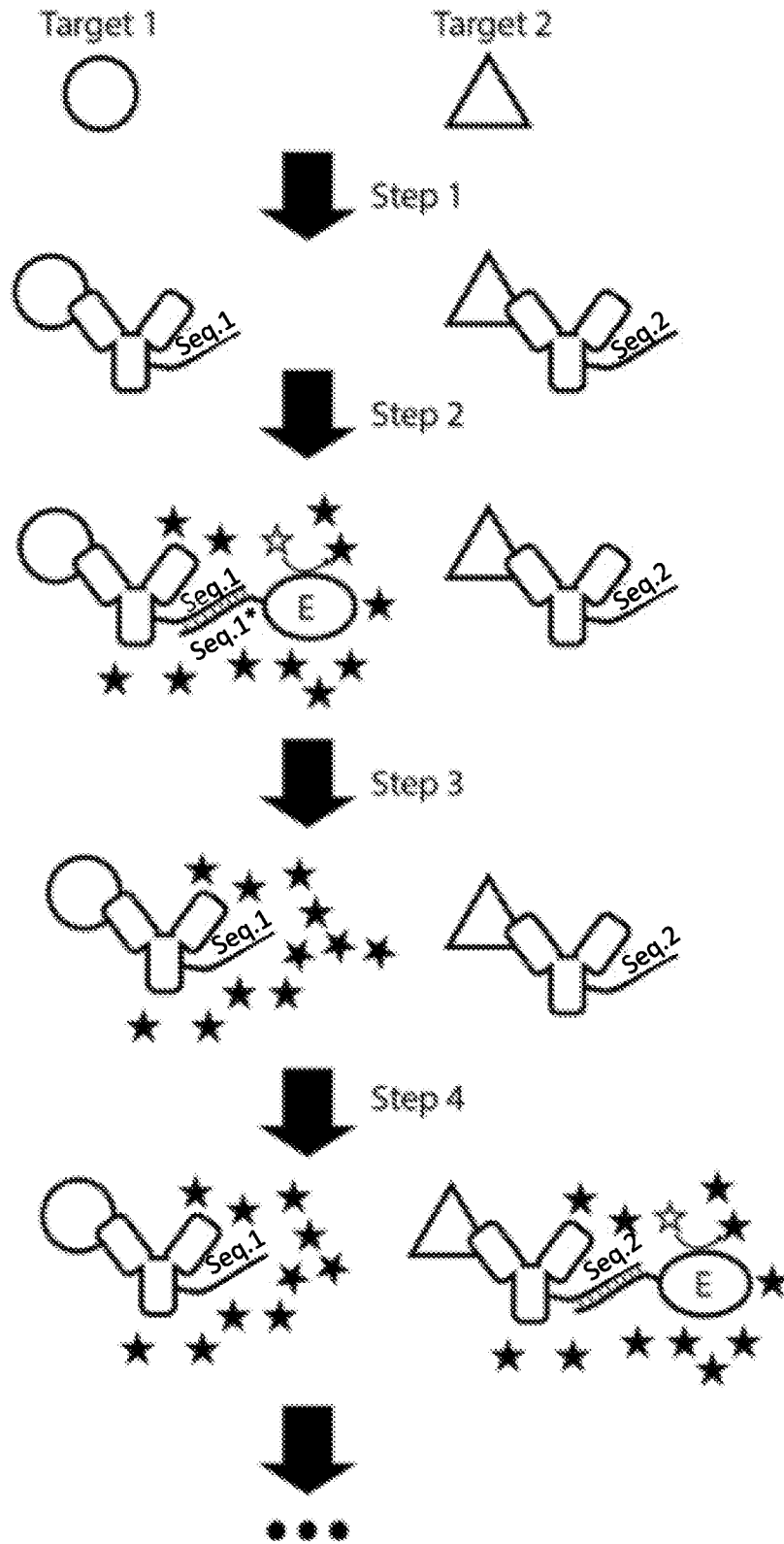

FIG. 4B

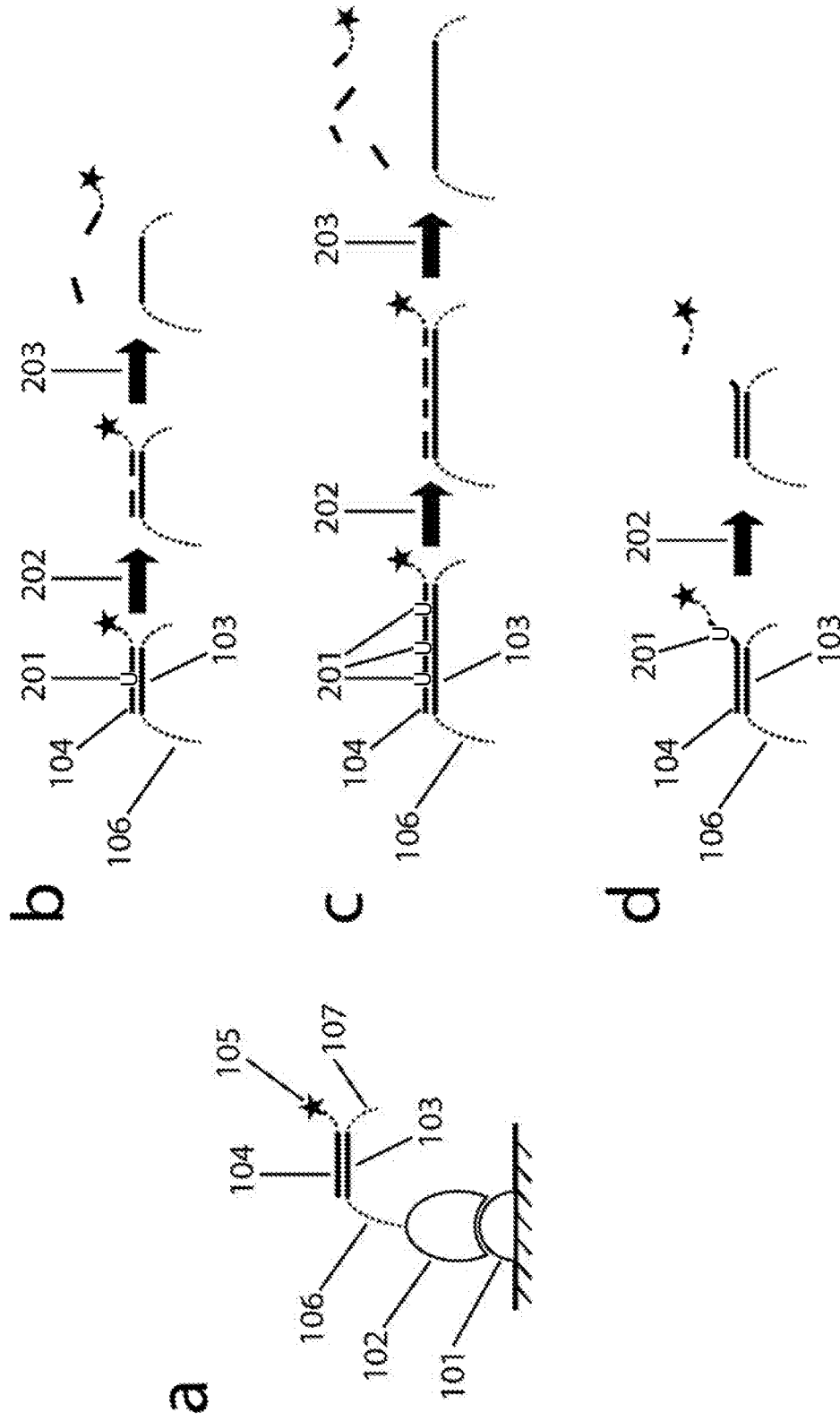

FIG. 5

9/23

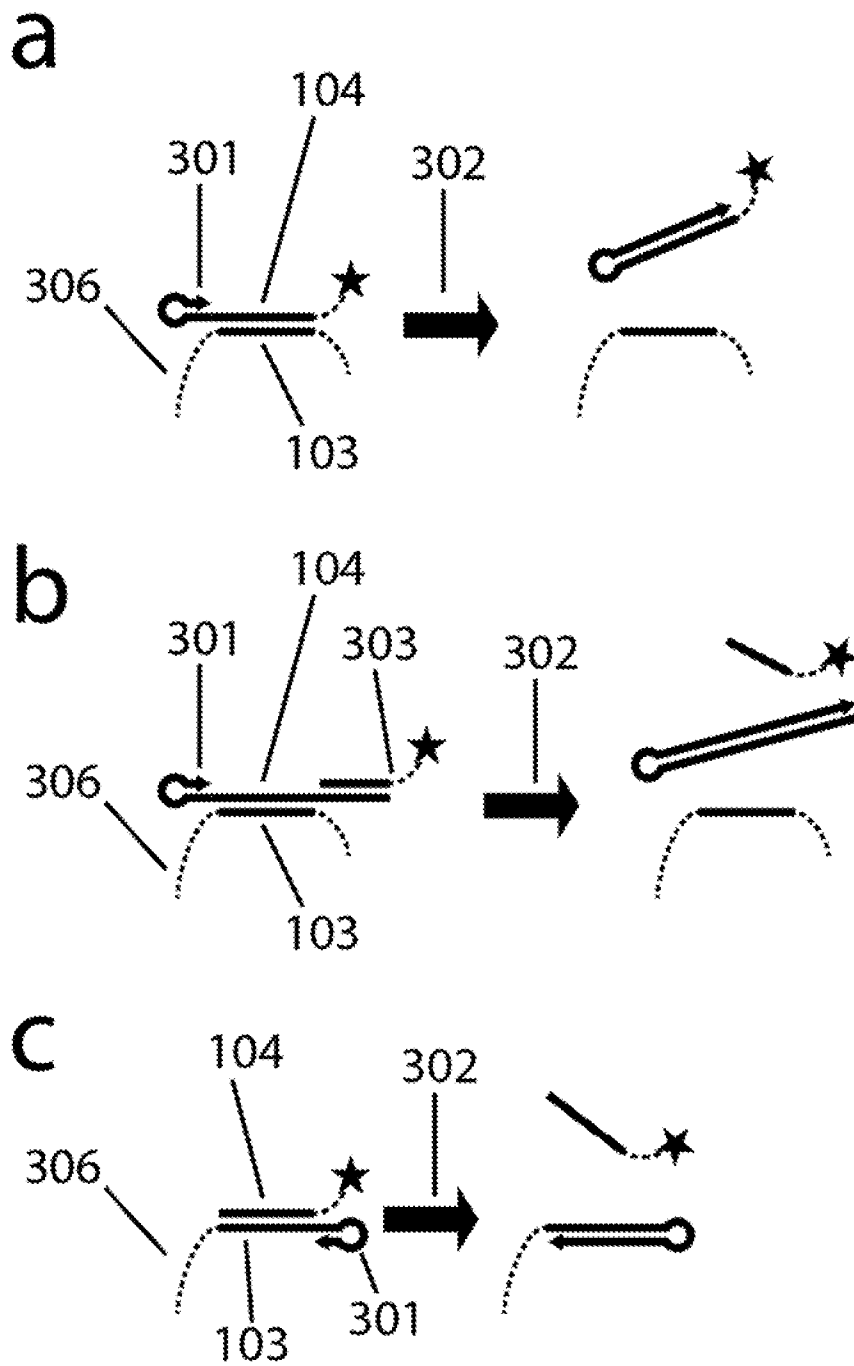

FIG. 6

10/23

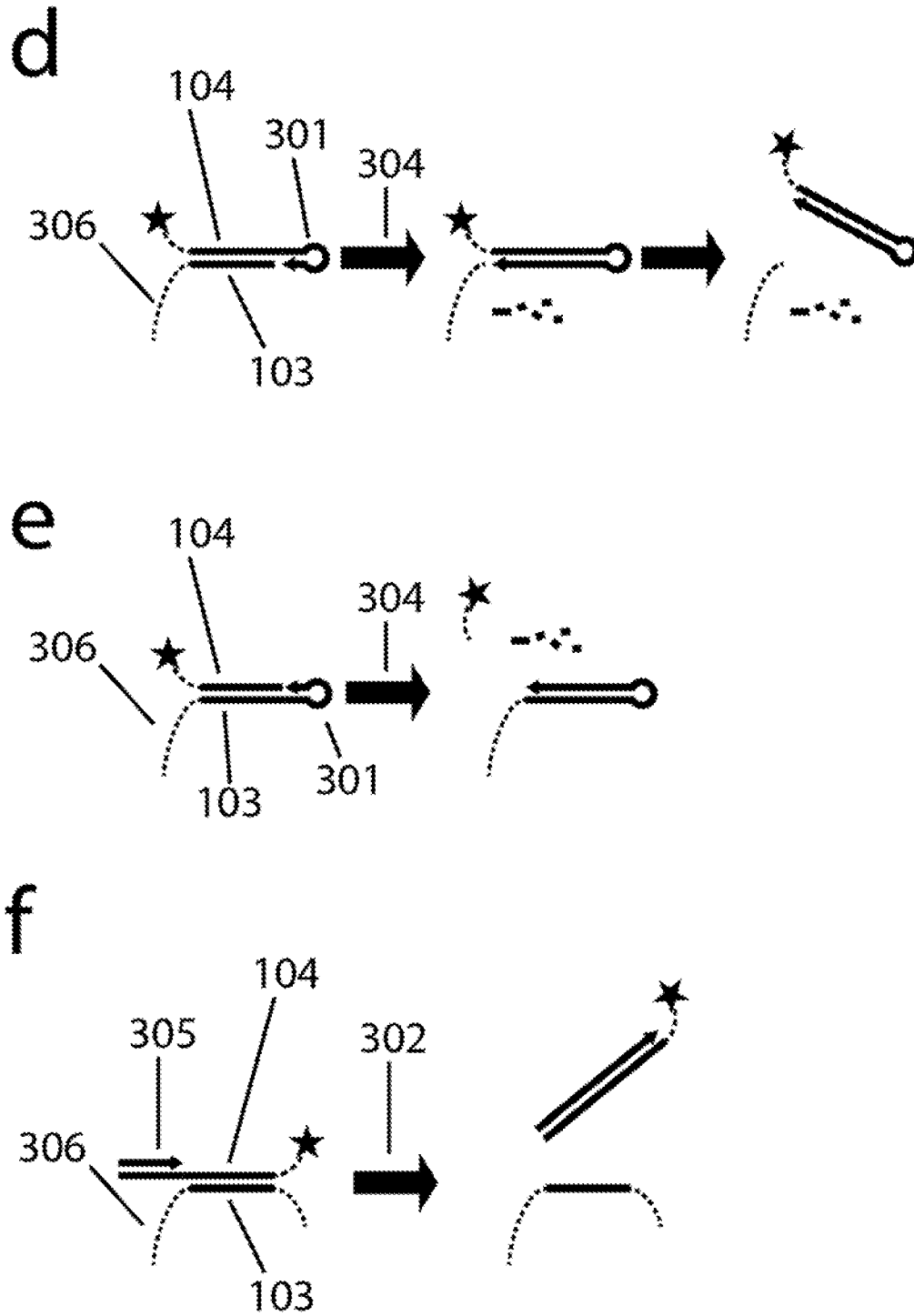

FIG. 6

11/23

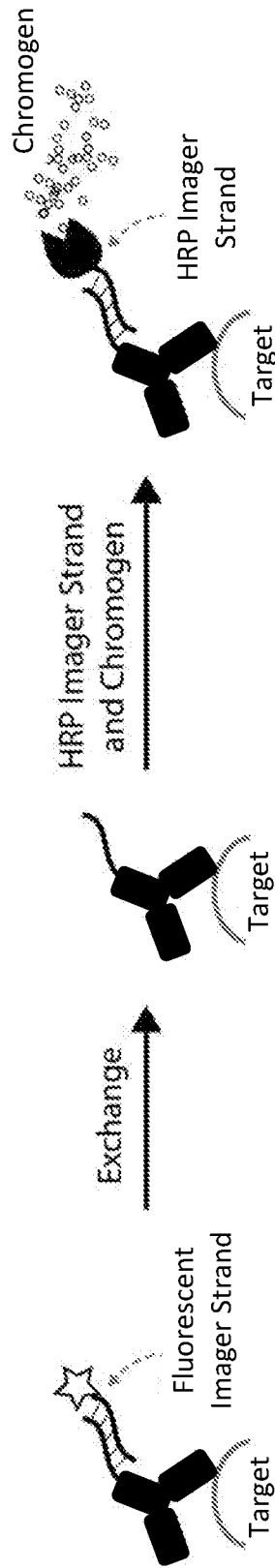

FIG. 7A

12/23



FIG. 7C

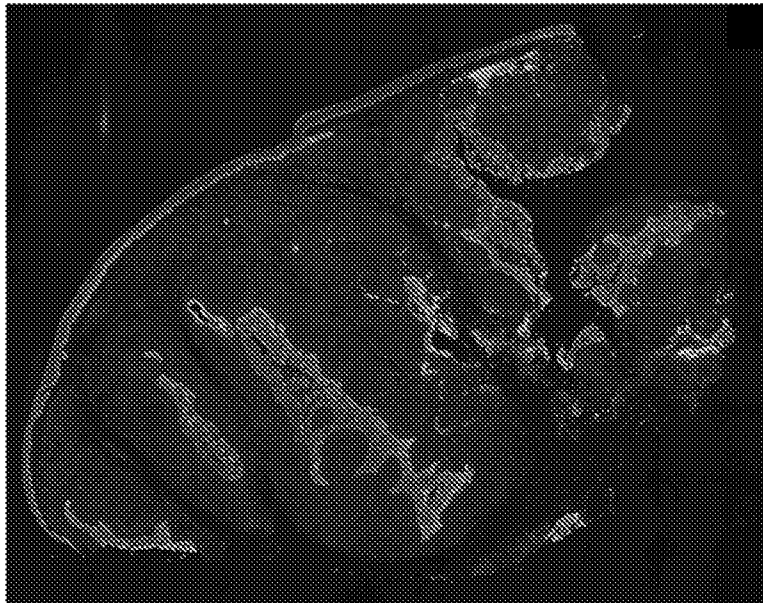
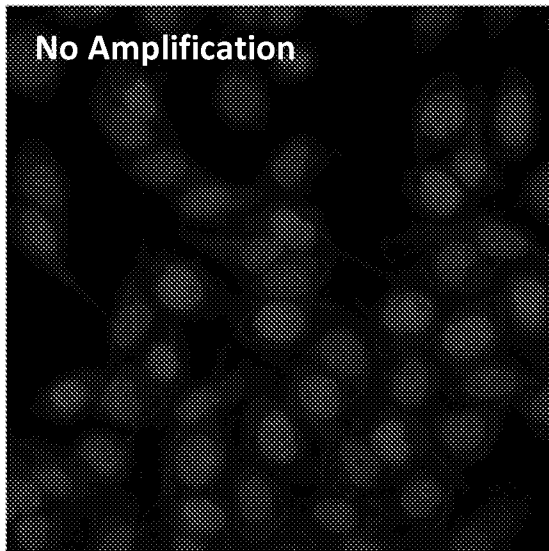
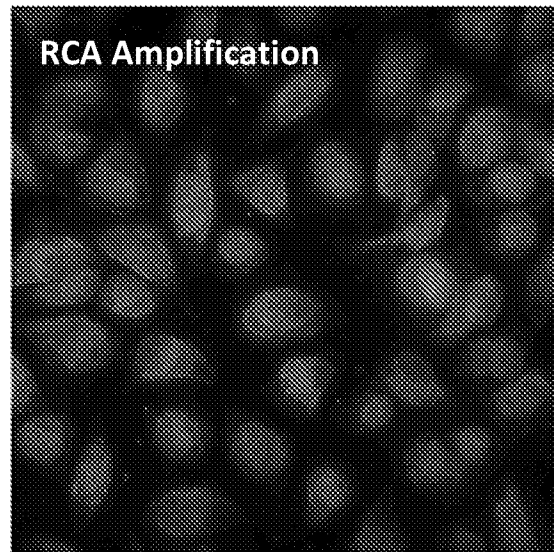

FIG. 7B



**FIG. 7D**



**FIG. 7E**

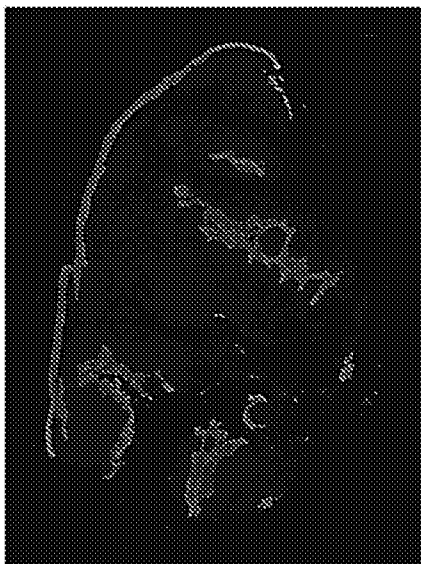

**FIG. 7F**



**FIG. 7G**

14/23

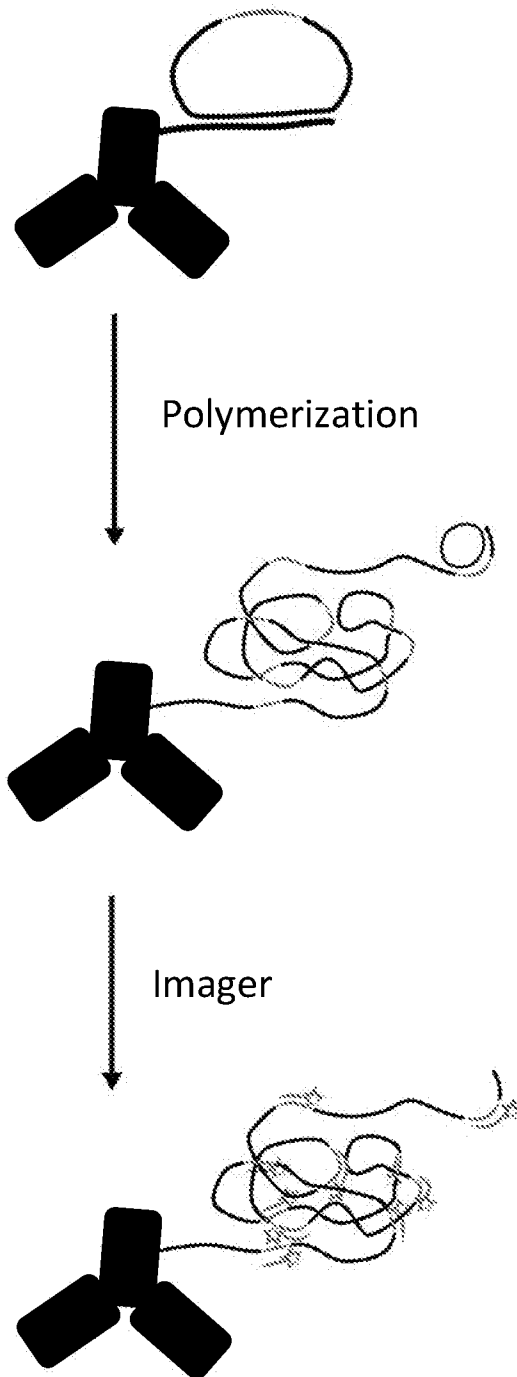

FIG. 8

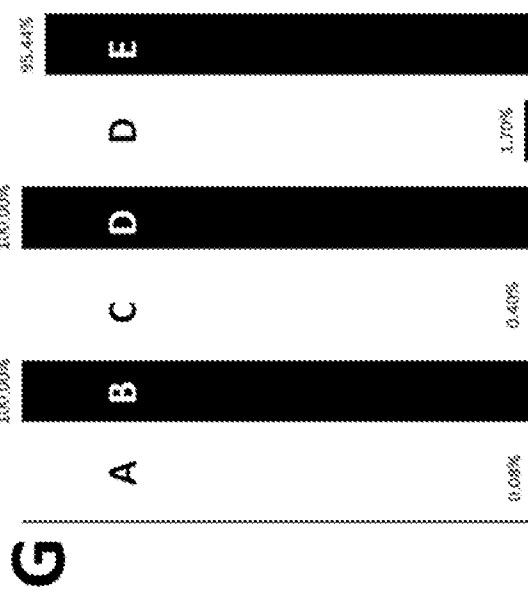
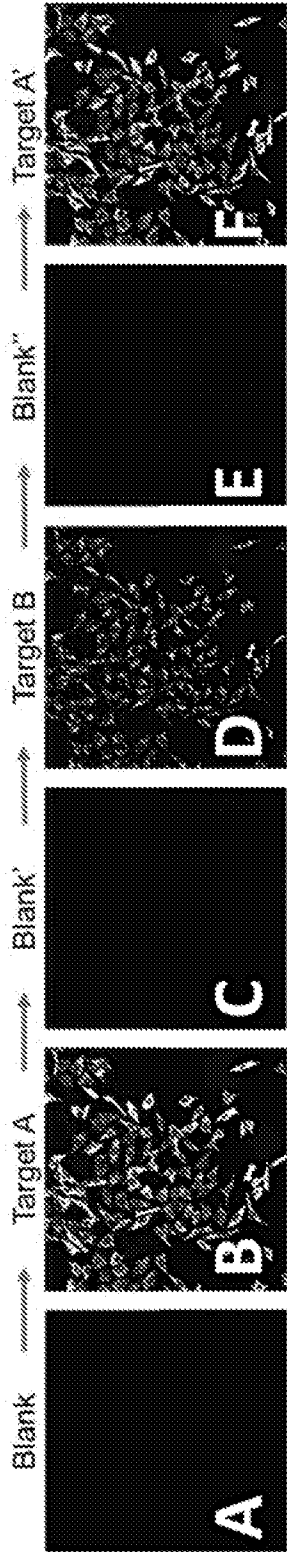

FIG. 9

16/23

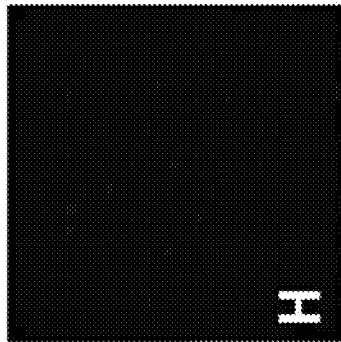
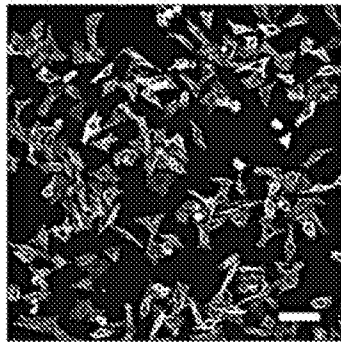
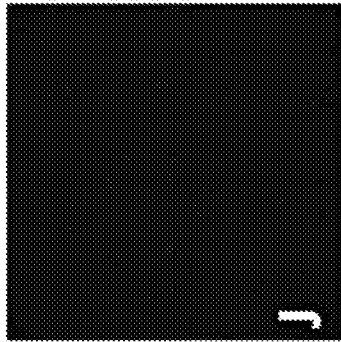
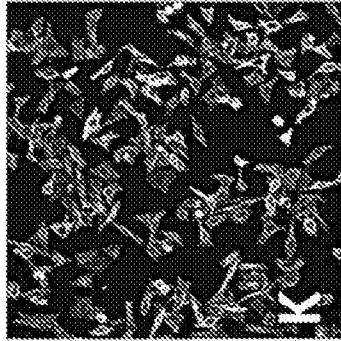

FIG. 9

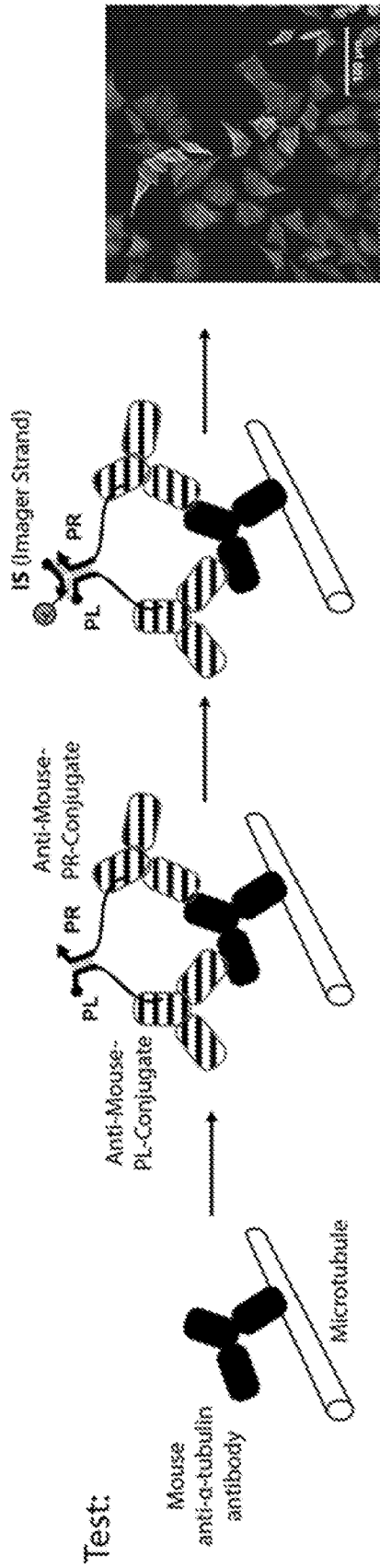

FIG 10A

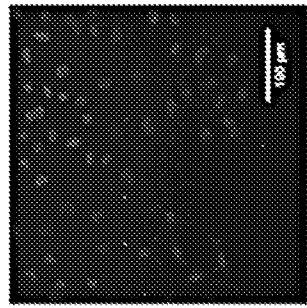
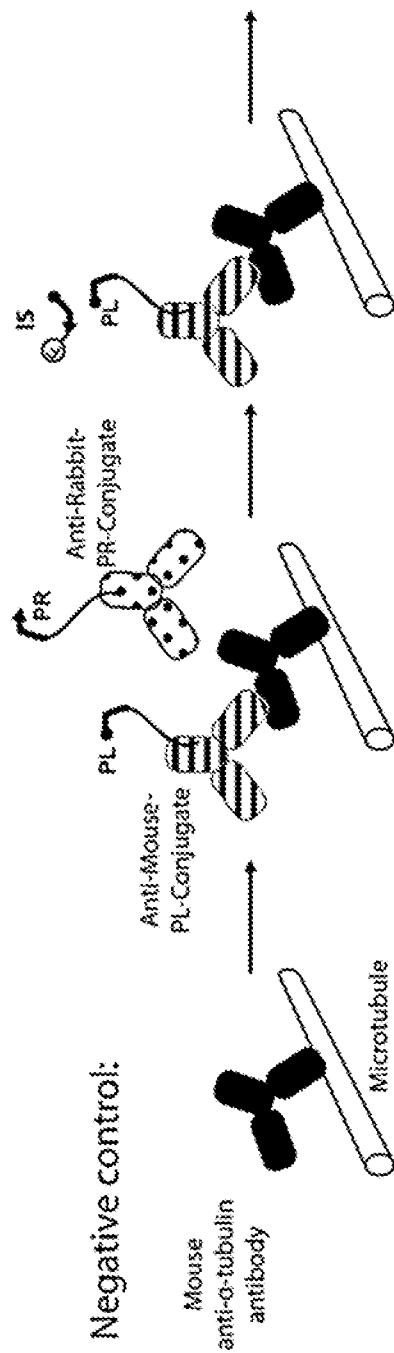
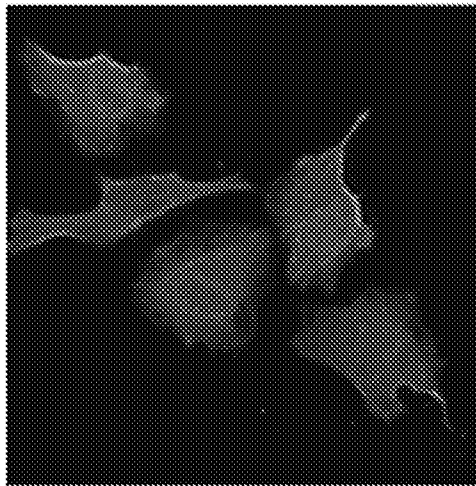

FIG 10B

**On-Target Image**



Docking strand A  
imaged with Imager  
strand A

**FIG. 11A**

**Off-Target Image  
No Cross-reactivity**

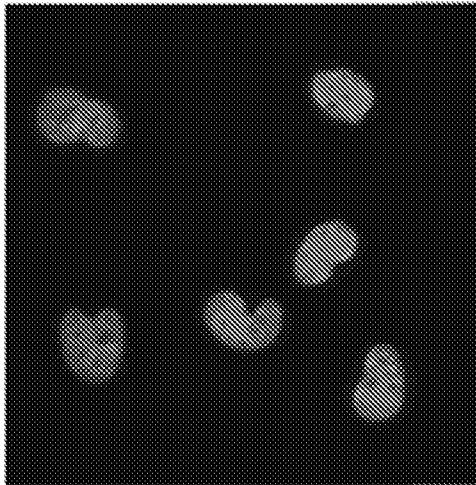

Docking strand A  
imaged with Imager  
strand B

**FIG. 11B**

**Off-Target Image  
w/ Cross-reactivity**

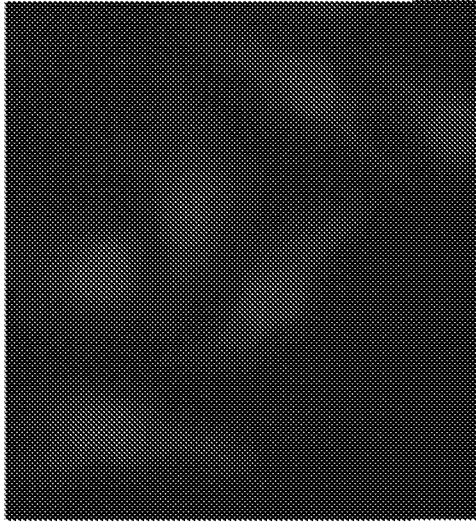

Docking strand A  
imaged with Imager  
strand C

**FIG. 11C**

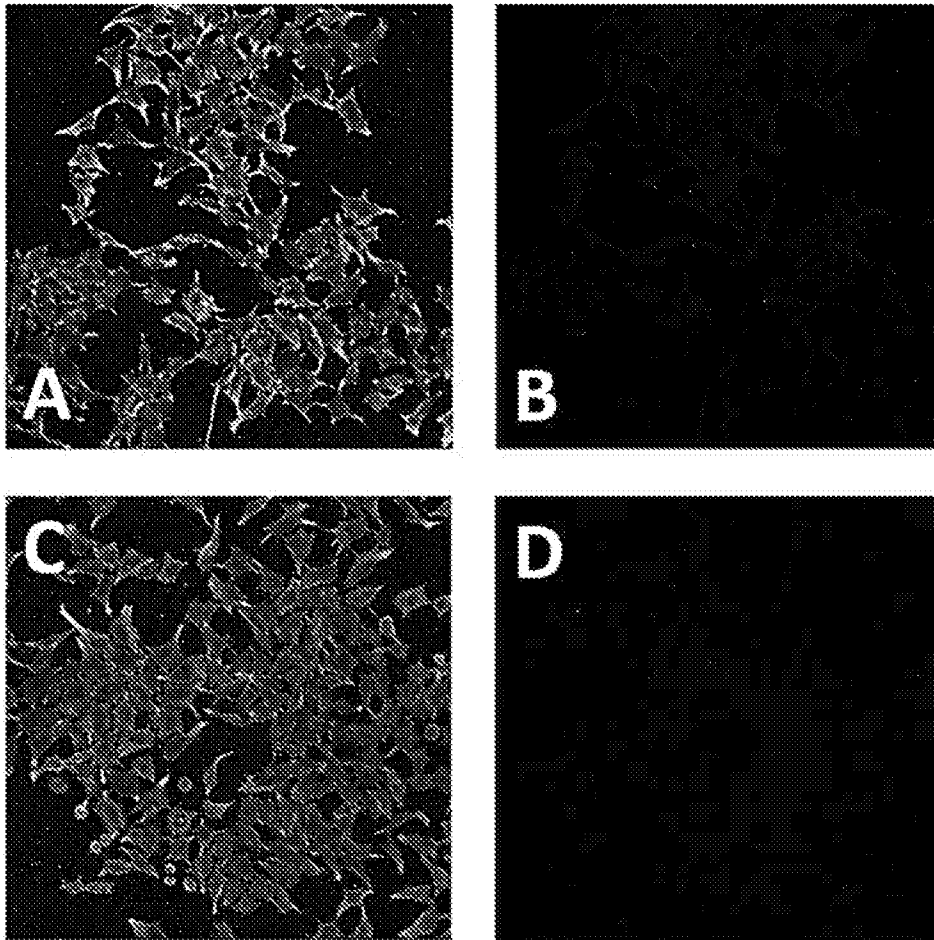

FIG 12

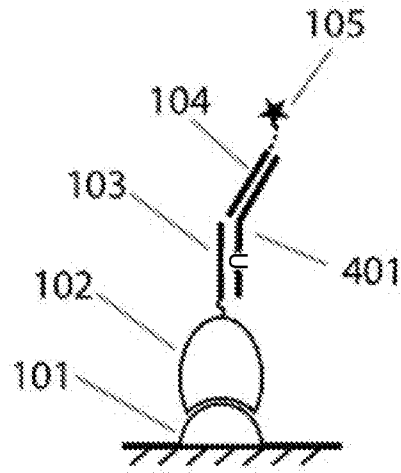

FIG 13A

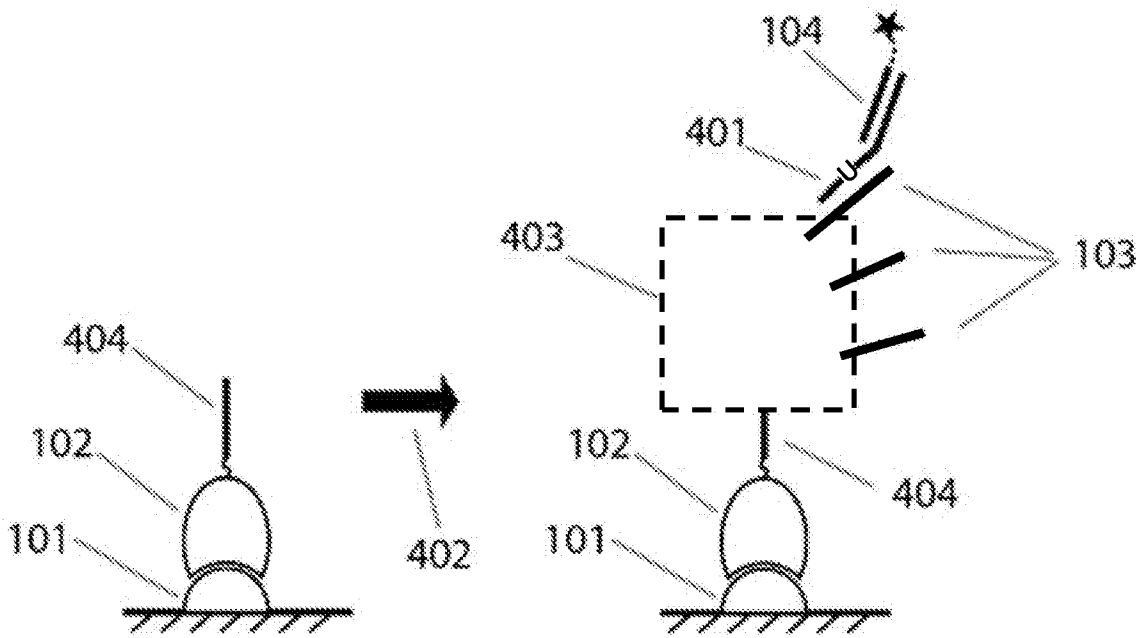

FIG 13B

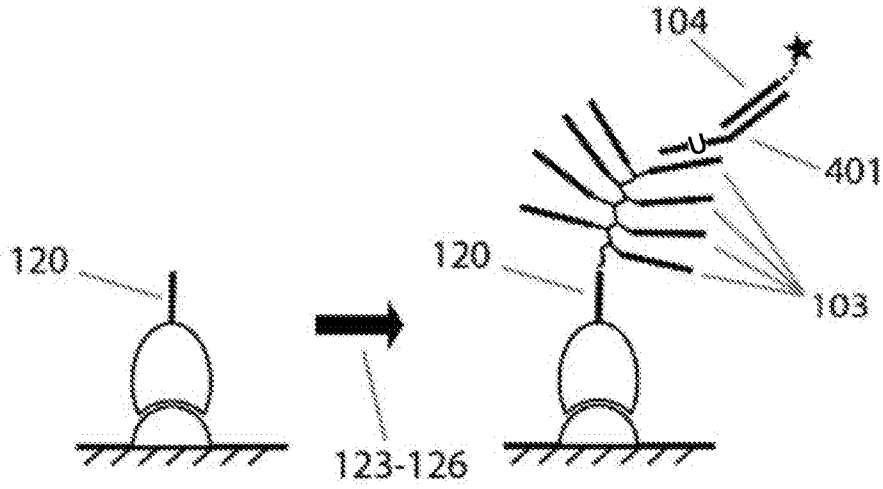

FIG 13C

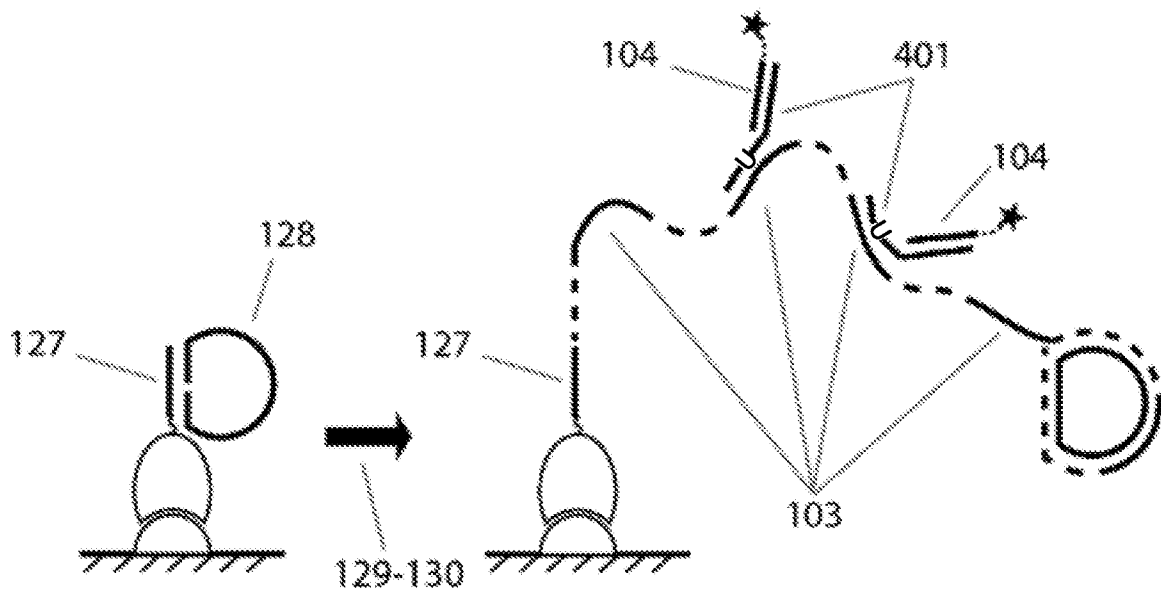
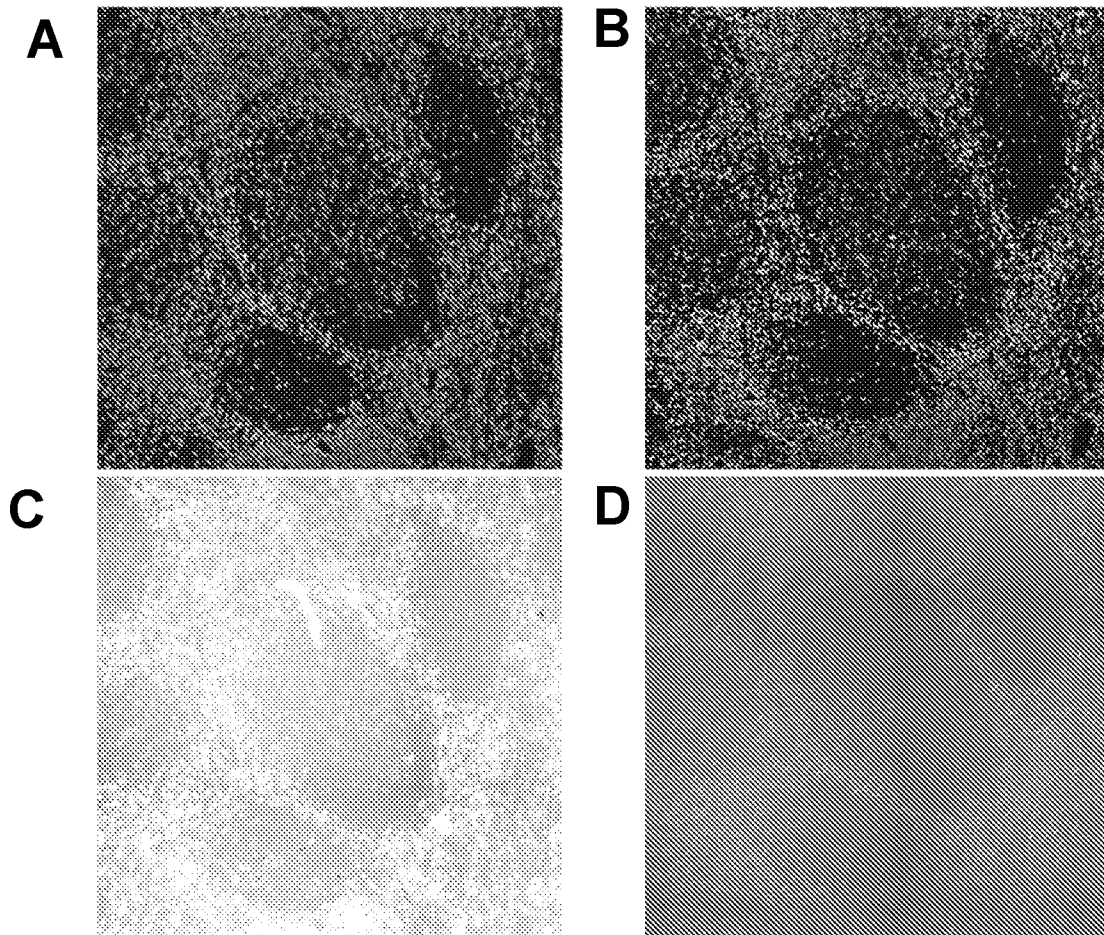

FIG 13D

22/23



**FIG 14**

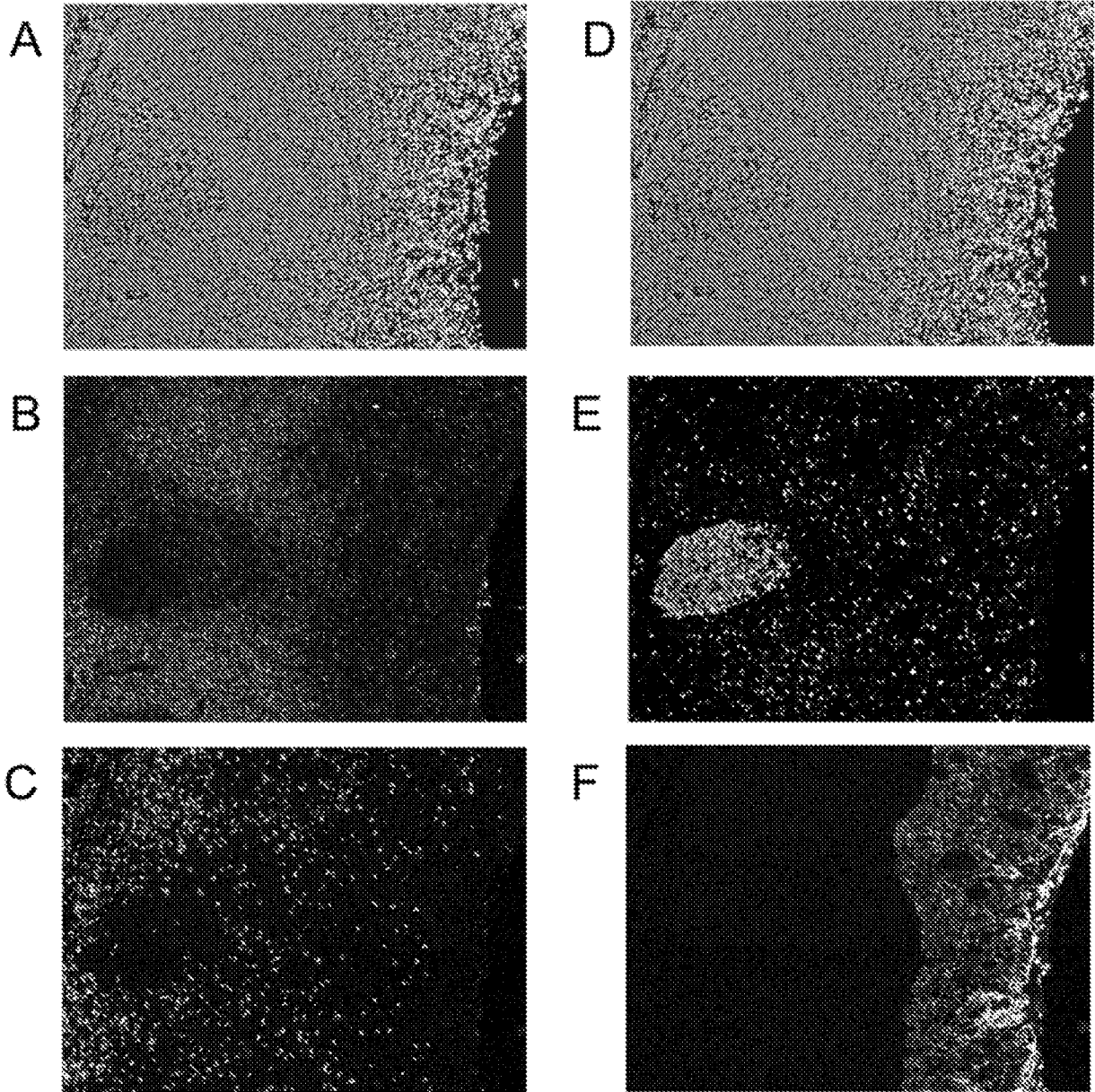

FIG 15