

L. NORTH.  
Cooking Stove.

No. 1,395.

Patented Oct. 31, 1839.

*Fig. 1.*

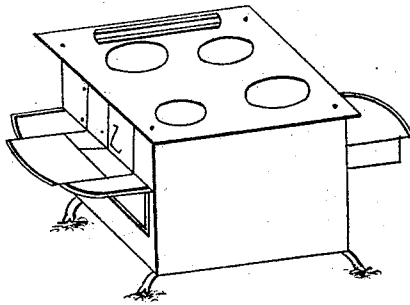

*Fig. 2.*

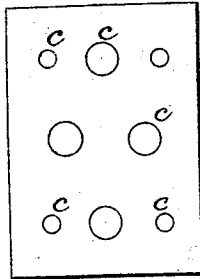

*Fig. 3.*



*Fig. 4.*



*Fig. 5.*

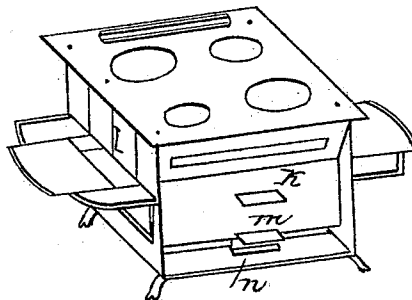

# UNITED STATES PATENT OFFICE.

LINUS NORTH, OF PALMYRA, NEW YORK.

## METHOD OF CONSTRUCTING FLUES OF STOVES.

Specification of Letters Patent No. 1,395, dated October 31, 1839.

*To all whom it may concern:*

Be it known that I, LINUS NORTH, of Palmyra, in the county of Wayne and State of New York, have invented a new and useful  
5 Improvement in Ovens of Stoves; and I do hereby declare that the following is a full and exact description of said improvement.

The nature of my invention consists in providing small cylinders or plates which I name fire breakers. These are located in the flue under, over and around the oven of the stove, by the judicious arrangement of which the flame and hot air are so broken, divided and spread as to equalize the heat on  
15 all parts of the oven.

To enable others skilled in the art to make and use my invention I will describe its construction and operation.

I construct my stoves in any of the known  
20 forms which have a flue under and around the oven.

The diving draft stove I construct as shown at Figure 1, in the accompanying drawing, with a flue passing around the  
25 oven. My fire breakers may be made in any form which will stand in the flue so as to break and divide the flame and hot air in their passage around the oven, but are best constructed in hollow cylinders as shown at  
30 Fig. 2, letters *c*, or in plates as shown at Figs. 3, 4, and 5. These fire breakers are in all cases made in height equal or nearly equal to the opening or depth of the flue around the oven, and in width or diameter  
35 they are from one inch to six or more inches, increasing according to the size of the stove, A.

Note A: To insure a good action of heat and draft the flue should in no case be less  
40 than two inches, nor more than three inches in its opening or depth, and the fire breakers should not be so wide as to make the open passage in the flue where they stand less than the draft hole of the stove.

A plate fire breaker may be made of wrought or cast iron; it should be a plate of from one eighth to one fourth of an inch in thickness, four inches wide, and three inches long, a bar may be extended from the  
50 breaker so as to reach across the whole width of the flue and be held in its place by cleats on the side plates of the stove; this fire breaker is shown at Fig. 5, in the accompanying drawing.

55 Two, three or more breakers may be at-

tached to the same bar, as shown at Figs. 3 and 4. Or this breaker may be attached to the end and bottom plates of the oven in casting or by riveting, as shown in Fig. 6, letter *k*.

A cylinder fire breaker may be formed of wrought or cast iron. It is formed of wrought iron by using a piece of sheet iron twelve and a half inches long and three inches wide. Roll this into a hollow cylinder and lock or rivet the ends together. This makes a hollow cylinder fire breaker four inches in diameter and three inches in length. This breaker may be attached to a bar or to the stove-plates in the same manner as the plate breaker, see Fig. 2, where these breakers are represented as standing on the bottom plate of the stove, letters *c*.

The fire breakers are placed in the flue of the stove in such an arrangement as to break and divide the flame and hot air into streams in their passage around the oven.

Example: In the diving draft stove, Fig. 6, a fire breaker four inches wide should be placed in the center of the flue on the front end of the oven and about three inches below the top of the oven, as shown at letter *k*. Another breaker of the same size should be placed directly under the first at the bottom of the oven, as shown at letter *m*, or it may be placed about two inches under the bottom of the oven as shown at letter *n*. A third and similar breaker should be placed under the center of the oven bottom, (invisible in the figure) a fourth breaker should be placed about two inches under the back end of the oven bottom or at the bottom of the end plate of the oven as the flue ascends and a fifth and similar breaker should be placed directly above this in the center of the flue about three inches below the top of the oven. The three last named breakers may be represented in their place at letters *n*, *m*, and *k* by supposing the stove, Fig. 6, to be changed end for end.

Stoves having a flue over the top of the oven require the same arrangement of the fire breakers in the top flue as has been named for the bottom flue. This arrangement of the fire breakers is for the smallest size of stoves. As the stove is increased in size the fire breakers should be wider and additional narrow breakers should be placed three or four inches distant from each other on each side of the first named line of break-

60

65

70

75

80

85

90

95

100

105

110

ers. A sheet iron cylinder breaker is to be preferred under the bottom of the oven and the location of the breakers as seen in Fig. 2, is good.

5 The effect of the fire breakers is to break the attraction which the flame and hot air have for themselves and compel them to pass in streams, while their attractive and expansive properties are left free to act as  
10 they pass from one row of breakers to another and thus by the alternate action of the breakers and the attractive and expansive properties of the elements the heat is  
15 spread uniformly over the whole body of the oven.

What I claim as my invention, and desire to secure by Letters Patent, is—

The employment of fire breakers, located in the flue, under, over, or around the oven of a stove, by which the flame and hot air, 20 are broken and spread, and the heat more equally diffused, through all parts of the oven, in the manner herein described, using for this purpose, any material, in any shape, which can be placed in the flue around the 25 oven, so as to produce the intended effect.

LINUS NORTH.

Witnesses:

B. R. NORTON,  
D. HOTCHKISS.