

(19)



(11)

**EP 2 016 866 A1**

(12)

**EUROPEAN PATENT APPLICATION**

(43) Date of publication:  
**21.01.2009 Bulletin 2009/04**

(51) Int Cl.:  
**A47C 1/02 (2006.01)**

(21) Application number: **08012969.5**

(22) Date of filing: **17.07.2008**

(84) Designated Contracting States:  
**AT BE BG CH CY CZ DE DK EE ES FI FR GB GR HR HU IE IS IT LI LT LU LV MC MT NL NO PL PT RO SE SI SK TR**  
Designated Extension States:  
**AL BA MK RS**

(72) Inventors:  
• **Morita, Yoshitoshi**  
**Hyogo 675-2332 (JP)**  
• **Watanabe, Tsuyoshi**  
**Hyogo 675-2332 (JP)**  
• **Nomura, Hidefumi**  
**Hyogo 675-2332 (JP)**

(30) Priority: **19.07.2007 JP 2007187887**

(74) Representative: **Wagner, Bernhard Peter**  
**ter Meer Steinmeister & Partner GbR**  
**Mauerkircherstrasse 45**  
**81679 München (DE)**

(71) Applicant: **Sanyo Electric Co., Ltd.**  
**Osaka 570-8677 (JP)**

(54) **Chair-type massage machine**

(57) The invention provides a chair-type massage machine comprising a backrest and a seat which can be reclined by a single drive source while permitting the user to hold a relaxed posture. The chair-type massage machine comprises a backrest (20) for the back of the user to bear on, a seat (30) for the user to sit in, and a reclining mechanism (40) for pivotally moving the backrest (20)

and the seat (30). The reclining mechanism (40) comprises a single drive source (42), the drive source being coupled to the backrest (20) and the seat (30) by a link assembly (50). The link assembly is operable to pivotally move the backrest (20) from a raised position to a reclined position via an intermediate position by operating the drive source (42).

F I G . 1

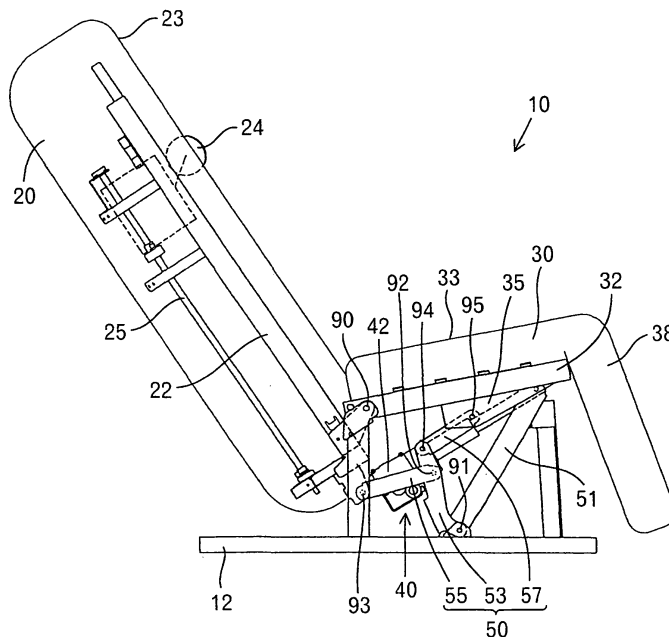

**EP 2 016 866 A1**

## Description

### FIELD OF THE INVENTION

**[0001]** The present invention relates to massage machines of the chair type having a backrest and a seat which can be reclined. More particularly, the invention relates to chair-type massage machines comprising a backrest and a seat which can be reclined by a single drive source while permitting the person to be treated to hold a relaxed posture.

### BACKGROUND OF THE INVENTION

**[0002]** Chair-type massage machines are known in which a backrest and a seat have massage means and can be reclined. For example, JP2003-289975A discloses such a massage machine comprising a reclining mechanism having independent drive sources provided for the respective backrest and seat so as to render each of the backrest and the seat reclinable independently of the other.

**[0003]** The provision of the independent drive sources for the respective backrest and seat makes the reclining mechanism large-sized and complex to consequently make the chair-type massage machine greater in size and complex in the mode of control.

Furthermore, the reclining mechanism comprising a plurality of drive sources encounters difficulty in positioning the backrest and the seat at a target angle in synchronism due, for example, to anomalies in the individual drive sources and variations in the load to be applied to the respective drive sources. The massage machine will then involve such an unnatural movement that one of the backrest and seat reaches the target angle with a delay after the other component has reached the target angle.

**[0004]** An object of the present invention is to provide a chair-type massage machine comprising a backrest and a seat which can be reclined by a single drive source while permitting the user to hold a relaxed posture.

### SUMMARY OF THE INVENTION

**[0005]** To fulfill the foregoing object, the present invention provides a chair-type massage machine comprising a backrest for the back of the user to bear on, a seat for the user to sit in, and a reclining mechanism for pivotally moving the backrest and the seat.

The reclining mechanism comprises a single drive source, and the drive source is coupled to the backrest and the seat by a link assembly.

The link assembly is operable to pivotally move the backrest from a raised position to a reclined position via an intermediate position by operating the drive source, the seat being tiltable to raise a front end thereof when the backrest is pivotally moved from the raised position to the intermediate position, the seat being tiltable to lower the raised lower end thereof when the backrest is pivotally

moved from the intermediate position to the reclined position.

By virtue of this construction, the backrest and the seat can be reclined while permitting the user to hold a relaxed posture.

**[0006]** The present invention also provides a chair-type massage machine comprising a backrest for the back of the user to bear on, a seat for the user to sit in, and a reclining mechanism for pivotally moving the backrest and the seat.

The reclining mechanism comprises a single drive source, the drive source being coupled to one of the backrest and the seat, the backrest or the seat having the drive source coupled thereto being pivotally movably supported.

The backrest is connected to the seat by a link assembly having a joint portion, which is movable along a guide rail. The drive source is operable to move the joint portion of the link assembly along the guide rail, as coupled to the pivotal movement of the backrest or the seat, and to pivotally move the backrest from a raised position to a reclined position via an intermediate position, the guide rail having a curved guide face for tilting the seat to raise a front end thereof when the backrest is pivotally moved from the raised position to the intermediate position and for tilting the seat to lower the raised front end thereof when the backrest is pivotally moved from the intermediate position to the reclined position.

By virtue of this construction, the backrest and the seat can be reclined while permitting the user to hold a relaxed posture.

**[0007]** The present invention further provides a chair-type massage machine wherein a base is provided with a backrest for the back of the user to bear on, a seat for the user to sit in, and a reclining mechanism for pivotally moving the backrest and the seat.

The reclining mechanism comprises a single drive source, which is coupled to one of the backrest and the seat. The backrest or the seat having the drive source coupled thereto is pivotally movably supported.

A link is pivoted at one end thereof to the backrest or the seat having the drive source coupled thereto, the link having the other end pivoted to a cam member supported by the base, the cam member being provided at a portion thereof with a cam face in bearing contact with the backrest or the seat not coupled to the drive source,

The drive source is operable to cause the link to rotate the cam member and to pivotally move the backrest from a raised position to a reclined position via an intermediate position, the cam face being so shaped as to tilt the seat to raise a front end thereof when the backrest is pivotally moved from the raised position to the intermediate position and as to tilt the seat to lower the raised front end thereof when the backrest is pivotally moved from the intermediate position to the reclined position.

By virtue of this construction, the backrest and the seat can be reclined while permitting the user to hold a relaxed posture.

**[0008]** In any one of the forgoing chair-type massage machines, a single drive source is provided for the reclining mechanism, which is therefore unlikely to become large-sized or complex. Furthermore, the use of the link assembly or the like assures a stabilized reclining movement free of variations.

#### BRIEF DESCRIPTION OF THE DRAWINGS

##### **[0009]**

FIG. 1 is shows a chair-type massage machine of first embodiment of the invention in a raised position; FIG. 2 is shows the chair-type massage machine of the first embodiment of the invention in an intermediate position; FIG. 3 is shows the chair-type massage machine of the first embodiment of the invention as reclined; FIG. 4 is a view showing a chair-type massage machine in a reclined position and having a link assembly of different embodiment; FIG. 5 is a view showing a chair-type massage machine in a reclined position and having a link assembly of another different embodiment; FIG. 6 includes a side elevation of a chair-type massage machine of second embodiment of the invention and an enlarged fragmentary view; FIG. 7 includes a side elevation of the chair-type massage machine of the second embodiment of the invention and an enlarged fragmentary view; FIG. 8 includes a side elevation of the chair-type massage machine of the second embodiment of the invention and an enlarged fragmentary view; FIG. 9 includes a side elevation of the chair-type massage machine of second embodiment of the invention and an enlarged fragmentary view; FIG. 10 includes a side elevation of a chair-type massage machine of third embodiment of the invention and an enlarged fragmentary view; FIG. 11 includes a side elevation of the chair-type massage machine of the third embodiment of the invention and an enlarged fragmentary view; FIG. 12 includes a side elevation of the chair-type massage machine of the third embodiment of the invention and an enlarged fragmentary view; FIG. 13 includes a side elevation of the chair-type massage machine of the third embodiment of the invention and an enlarged fragmentary view; FIG. 14 includes a side elevation of the chair-type massage machine of the third embodiment of the invention and an enlarged fragmentary view; FIG. 15 includes a side elevation of a chair-type massage machine of fourth embodiment of the invention and an enlarged fragmentary view; FIG. 16 includes a side elevation of the chair-type massage machine of the fourth embodiment of the invention and an enlarged fragmentary view; FIG. 17 includes a side elevation of the chair-type

massage machine of the fourth embodiment of the invention and an enlarged fragmentary view; FIG. 18 includes a side elevation of the chair-type massage machine of the fourth embodiment of the invention and an enlarged fragmentary view; FIG. 19 includes a side elevation of the chair-type massage machine of the fourth embodiment of the invention and an enlarged fragmentary view; FIG. 20 includes a side elevation of a chair-type massage machine of fifth embodiment of the invention and an enlarged fragmentary view; FIG. 21 includes a side elevation of the chair-type massage machine of the fifth embodiment of the invention and an enlarged fragmentary view; FIG. 22 includes a side elevation of the chair-type massage machine of the fifth embodiment of the invention and an enlarged fragmentary view; FIG. 23 includes a side elevation of the chair-type massage machine of the fifth embodiment of the invention and an enlarged fragmentary view; FIG. 24 includes a side elevation of the chair-type massage machine of the fifth embodiment of the invention and an enlarged fragmentary view; FIG. 25 includes a side elevation of a chair-type massage machine of sixth embodiment of the invention and an enlarged fragmentary view; FIG. 26 includes a side elevation of the chair-type massage machine of the sixth embodiment of the invention and an enlarged fragmentary view; FIG. 27 includes a side elevation of the chair-type massage machine of the sixth embodiment of the invention and an enlarged fragmentary view; FIG. 28 includes a side elevation of the chair-type massage machine of the sixth embodiment of the invention and an enlarged fragmentary view; and FIG. 29 includes a side elevation of the chair-type massage machine of the sixth embodiment of the invention and an enlarged fragmentary view;

#### DESCRIPTION OF THE PREFERRED EMBODIMENTS

[Embodiment 1]

**[0010]** The present invention provides chair-type massage machines 10, which will be described below with reference to the drawings.

First, the overall construction of the chair-type massage machine 10 will be described generally. As shown in FIG. 1, the massage machine 10 has a base 12 to be placed on the floor. Using pivots 90, the base 12 has supported thereon a seat 30 for the user to sit in and a backrest 20 for the back of the user to bear on. The seat and the backrest are pivotally movable by the reclining mechanism 40 to be described below.

The backrest 20 comprises a backrest frame 22 and a cushion 23 or the like provided around the frame 22 and is provided in its interior with massage means 24 movable upward and downward by a lift unit 25 for massaging the

shoulders, back, waist, etc. of the user.

The seat 30 comprises a cushion 33 or the like provided around a seat frame 32 and is provided in its interior with an air bag or like massage means (not shown) as required. A leg portion 38 for placing thereon the legs of the user can be provided at the front end of the seat 30. The leg portion 38 shown in FIG. 1 is made integral with the seat 30, whereas the leg portion 38 may be adapted to accommodate therein the calves and the feet for a massage unit (not shown) to give a massage to the calves as shown in FIG. 6 or the like to be described later. The leg portion 38 may be made pivotally movable relative to the seat 30.

**[0011]** The reclining mechanism 40 comprises a drive source 42 and a link assembly 50. The reclining mechanism 40 of the present invention is characterized in that both the backrest 20 and the seat 30 can be reclined by the single drive source 42. Furthermore, the backrest 20 and the seat 30 can be reclined while permitting the user to hold a relaxed posture.

**[0012]** The expression that the user as positioned in a relaxed posture refers to such a state of the user that he or she is not particularly burdened on his body, or is not locally subjected to a force, or will not assume any objectionable posture when the backrest 20 is reclined with the user seated in the seat 30 with his back bearing on the backrest 20.

If the backrest 20 only is merely reclined without tilting the seat 30, an objectionable force is likely to act on the abdominal muscle or waist to reduce the massage effect.

**[0013]** According to the present invention, therefore, the backrest 20 and the seat 30 can be reclined so as to retain the following "relax angle" in accordance with the reclining angle of the backrest 20, so that the machine can be reclined while permitting the user to hold a relaxed state.

**[0014]** First, when the backrest 20 is in a raised position (hereinafter referred to as the "raised position"), the seat 30 is so tilted that the front end of the seat 30 is positioned at a slightly higher level above the floor than the rear end thereof. This enables the user to seat deep in the seat 30 and feel relaxed.

**[0015]** As the backrest 20 is inclined backward from this raised position, the seat 30 is tilted with its front end moved up. This enables the user to follow the reclining movement of the backrest 20 and feel at ease without applying any force to the abdominal muscle. When the backrest 20 is reclined to an intermediate value of the greatest reclining angle (hereinafter referred to as an "intermediate position"), the seat 30 is inclined greatest with its front end raised to the highest level.

**[0016]** When the backrest 20 is reclined further from the intermediate position, the seat 30 is inclined with its front end moved down, and the seat 30 returns to the same angle as in the raised position upon the backrest 20 reaching the greatest reclining angle (hereinafter referred to as a "reclined position"), whereby the backrest 20 and the seat 30 are brought to a nearly flat state. After

the backrest 20 has moved past the intermediate position, the back of the body of the user is held fully in intimate contact with the backrest 20, with the center of gravity shifted toward the backrest 20. Accordingly, even if the seat 30 resumes such an angle that it is positioned nearly in parallel with the floor, the backrest 20 and the seat 30 can be brought to the flat state while permitting the user to remain relaxed with no objectionable force acting on the body of the user. Such angles enabling the user to feel relaxed will be referred to as "relaxing angles."

**[0017]** Since the user can be held in a relaxed posture free of any unnatural force acting on his body by adjusting the angle of inclination of the seat 30 in accordance with the reclining angle of the backrest 20, the massage operation to be subsequently performed can produce the greatest possible effect. The backrest 20 and the seat 30 can be returned from the flat state to the raised position through a movement reverse to the foregoing movement while permitting the user to remain relaxed, with the result that the massage effect given will not be nullified or diminished.

**[0018]** For example, FIG. 1 shows a single actuator serving as the single drive source 42 for the reclining mechanism 40. The actuator has one end connected to the upper end of a fixed frame 51 extending forwardly upward approximately from the center of the base 12. The other end of the actuator is connected to the lower end of the backrest 20.

The contraction of the actuator in the chair-type massage machine 10 pulls the lower end of the backrest 20 as supported by the pivots 90, whereby the backrest 20 itself is reclined as shown, for example, in FIGS. 2 and 3.

**[0019]** The link assembly 50 can be composed of a plurality of links 53, 55 and 57 in combination. With reference to FIG. 1, the link assembly 50 comprises a first link 53 pivoted as at 91 approximately to the center of the base 12, a second link 55 pivoted to a portion of the first link 53 close to the free end thereof and to the lower end of the backrest 20, respectively, as at 92, 93 for interconnecting the link 53 and the backrest 20, and a third link 57 pivoted to the free end extremity of the first link 53 and to a bracket 35 projecting from the bottom of the seat 30, respectively, as at 94, 95 for interconnecting the link 53 and the bracket 35.

The present embodiment reclines with the backrest 20 and the seat 30 held at a relaxing angle, and the seat 30 is held approximately at the same level in the raised position of FIG. 1 and in the reclined position of FIG. 3. For this reason, the first link 53 and the third link 57 move symmetrically about a vertical line in FIG. 1 and FIG. 3. The stroke length of the second link 55 operatively connected to the backrest 20 is so determined as to effect this movement. If the actuator serving as the drive source 42 has a sufficiently large stroke length, the pivot 92 between the second link 55 and the first link 53 can be positioned closer to the pivot 94 connecting the third link 57 to the first link 53, such that in an extreme case, pivots 92, 94 can be a common pivot.

Furthermore, the highest level of the front end of the seat 30 is adjustable by shifting the position of the pivot 95 for connecting the third link 57 to the seat 30. (As the pivot 95 is positioned closer to the pivot 90, the level can be higher.)

**[0020]** With the reclining mechanism 40 of the foregoing construction, the drive source 42 is operated, starting to recline the backrest 20 from the raised position of FIG. 1, whereby the second link 55 is pushed forward, and the first link 53 inclines forward about the pivoted point 91 on the base 12 to push out the third link 57 forward. This pivotally moves the seat 30, moving the front end thereof upward about the pivot 90.

When the backrest 20 reclines from the raised position to an intermediate position (an approximately intermediate position between the raised position of FIG. 1 and the reclined position of FIG. 3) as shown in FIG. 2, the link assembly 50 becomes so shaped that the first link 53 and the third link 57 are arranged along a straight line, bringing the front end of the seat 30 to the highest level. Accordingly, if the drive source 42 is further operated, the backrest 20 reclines from the intermediate position of FIG. 2, the second link 55 is pushed forward, and the first link 53 further inclines forward about the pivoted point 91 on the base 12. This reclines the third link 57, pulling down the raised front end of the seat 30 and consequently bringing the backrest 20 and the seat 30 to a flat state as shown in FIG. 3.

**[0021]** Thus, the backrest 20 is reclined by operating the drive source 42, whereby the seat 30 is also tilted, with the backrest 20 and the seat 30 held at a relaxing angle, so that the user as seated in the seat 30 can be moved to a lying position without permitting any disagreeable force acting on the body of the user.

With the backrest 20 and the seat 30 positioned flat, various modes of massage can be given by the massage means to massage the body effectively.

**[0022]** The backrest 20 and the seat 30 can be operated in a manner reverse to the above by operating the drive source in a direction opposite to the above, i.e., by extending the actuator in the illustrated embodiment, whereby the machine can be returned to the raised position while holding the relaxing angle.

**[0023]** The backrest 20 and the seat 30 can be inclined at different relaxing angles by varying the length of the links 53, 55, 57 of the link assembly 50 and shafting the position of the pivoted points 91, 92, 93, 94, 95.

**[0024]** Although the drive source 42 (actuator) is used for reclining the backrest 20 according to the foregoing description, an actuator may be provided between the first link 53 and the base 12 as shown in FIG. 4 to move the first link 53 about the pivot 91. Alternatively, an actuator may be provided between the pivot 94 for connecting the first link 53 to the third link 57 and the base 12 as shown in FIG. 5 for moving the first link 53 about the pivot 91.

[Embodiment 2]

**[0025]** FIGS. 6 to 9 show another chair-type massage machine 10 wherein a reclining mechanism 40 comprises a link assembly 50. A further detailed description is given of the relaxing angle between the backrest 20 and the seat 30. For a better understanding, the drive source 42 is not shown, whereas an actuator or the like is provided for reclining the backrest 20. Furthermore, cushions are not shown.

**[0026]** With reference to FIG. 6, the backrest 20 and the seat 30 are held at a relaxing angle, for example, of 109 degree when the chair-type massage machine 10 is in a raised position. As the backrest 20 is reclined to an intermediate position in this state as shown in FIGS. 7 and 8, the seat 30 is so tilted as to raise its front end. This decreases the angle between the backrest 20 and the seat 30 to 106 degree in FIG. 7, shifting the center of gravity of the user toward the backrest 20. Accordingly no objectionable force will act on the body of the user when the backrest 20 is reclined. When the first link 53 of the link assembly 50 is nearly aligned with the third link 57 thereof as seen in FIG. 8, the seat 30 has its front end raised to the highest level. When the backrest 20 is further reclined, the third link 57 is reclined about the pivot 94, pulling down the seat 30 as shown in FIG. 9. Thus, the backrest 20 and the seat 30 can be moved to a nearly flat state (the backrest 20 and the seat 30 shown are at a relaxing angle of 160 degree).

[Embodiment 3]

**[0027]** With Embodiments 1 and 2, the reclining mechanism 40 comprises a link assembly 50 for reclining the backrest 20 and the seat 30, whereas according to the present embodiment, the first link 53 is replaced by a guide rail 60 for realizing the same operation as above. Although the drive source 42 is not shown for a better understanding, an actuator or the like is provided for reclining the backrest 20 as in Embodiment 1. Furthermore, cushions and the like are not shown.

**[0028]** The same second link 55 and third link 57 of Embodiments 1 and 2 are connected together by a pivot 74, which has a roller 72. The roller 72 is supported by a flexible joint portion 70 and is movable on a guide rail 60 provided on the base 12. Preferably, the roller 72 and the guide rail 60 are so designed that one of them is shaped to have a recess, i.e., a groove, and the other thereof has a projection fittable in the groove.

**[0029]** Each of the second link 55 and the third link 57 has a length, which can be determined suitably, for example, in accordance with the position of the guide rail 60 and the level of the front end of the seat 30. The roller 72 provided on the joint portion 70 can be prepared from a resin.

**[0030]** The guide rail 60 has a curved guide face 62 for contact with the roller 72 so as to recline the backrest 20 and the seat 30 having the relaxing angle therebe-

tween.

**[0031]** With reference to Detail Drawing A of FIG. 10, the guide face 62 has a forwardly upward slope so as to make the seat 30 pivotally movable with its front end moving upward during the movement from a raised position to an intermediate position. When the backrest 20 is reclined from the raised position, the roller 72 is pushed by the second link 55 to move forwardly upward along the guide face 62, causing the third link 57 to push the front portion of the seat 30 upward as shown in FIGS. 11 and 12.

The curve of the guide face 62 has a recessed circular-arc form 64 which is centered about the pivot 90 serving as the center of pivotal movement of the seat 30 and the backrest 20. The backrest 20 and the seat 30, while holding a relaxing angle of 106 degree therebetween, can therefore recline until the seat 30 inclines through about 30 degree with respect to a horizontal plane. This is suitable in the case where the user reads books with the backrest 20 reclined at a desired angle.

**[0032]** With reference to FIG. 13, the guide face 62 changes from the recessed circular-arc form 64 to a projecting circular-arc form 65 at a position where the backrest 20 and the seat 30 reach the vicinity of the intermediate position. As the guide face 62 extends forward, the guide face has a downward slope 66. When the backrest 20 is further reclined from the intermediate position, the seat 30 having its front end raised is pulled down by the reclining of the third link 57, with the result that the backrest 20 and the seat 30 can be moved until they assume a flat state as seen in FIG. 14.

**[0033]** Thus, with the use of the guide rail 60, the relaxing angle between the backrest 20 and the seat 30 is made adjustable so that the user can hold a relaxed posture. The form of the guide face 62 need not be limited to that of the present embodiment. The guide face can be so shaped as in Embodiment 4 given below, or can be modified suitably in accordance with the desired relaxing angle.

[Embodiment 4]

**[0034]** FIGS. 15 to 19 show another embodiment comprising a guide rail 60 which is different from the one included in Embodiment 3. This embodiment is the same as Embodiment 3 with the exception of the form of the guide face 62.

**[0035]** This embodiment is so designed that the relaxing angle increases as the backrest 20 is reclined by a recessed circular-arc form 64 when the machine is brought from the raised position to the intermediate position. Stated more specifically, the relaxing angle is 106 degree in the raised position as shown in FIG. 15. The angle increases to 109 degree, 111 degree or 120 degree as shown in FIGS. 16 to 18. Accordingly, the body of the user as seated in the seat 30 can be reclined in a natural state, with his waist stretched gradually.

**[0036]** After the intermediate position shown in FIG.

18 has been reached, the guide face 62 extends forward substantially horizontally as indicated at 67. This causes the third link 57 to rotate in the reclining direction, pulling the raised front end of the seat 30 down, whereby the backrest 20 and the seat 30 are brought to a nearly flat state as shown in FIG. 19 (at 160 degree as illustrated).

[Embodiment 5]

**[0037]** FIGS. 20 to 24 show an embodiment wherein another different guide rail 60 is used.

**[0038]** With this embodiment, the guide face 62 has a recessed circular-arc form 64 centered about the pivot 95 for the third link 57, whereby the seat 30 can be held at rest (at a constant angle of 11 degree with the floor) until the backrest 20 is reclined from the raised position to 120 degree. The seat 30 thereafter rises and moves up to the highest level through 30 degree in FIG. 22. The seat then lowers to form an increased angle with the backrest 20.

**[0039]** After the intermediate position shown in FIG. 22 has been reached, the guide face 62 extends forward substantially horizontally as indicated at 67. The third link 57 rotates in the reclining direction, pulling the raised front end of the seat 30 down, whereby the backrest 20 and the seat 30 are brought to a nearly flat state as shown in FIG. 24 (at 160 degree as illustrated).

Thus, varying relaxing angles can be realized merely by modifying the form of the guide face 62.

**[0040]** According to Embodiments 3 to 5, the roller 72 serves as a pivot 74 for the joint portion 70, whereas the pivot 74 can be made movable on the guide face 62, with the roller 73 dispensed with.

[Embodiment 6]

**[0041]** This embodiment uses a cam 80 for giving an adjustable relaxing angle. For a better understanding, the drive source 42 is not shown, whereas an actuator or the like is provided for reclining the backrest 20 as in Embodiment 1. Cushions are not shown.

**[0042]** The cam 80 is pivoted at an eccentric position to a support bracket 84 projecting from the base 12 to provide a reclining mechanism 40. The cam 80 is coupled to the backrest 20 by a second link 55.

For example as shown in FIG. 25, the cam 80 has an approximately elliptical cam face 82 on its outer periphery. The support bracket 84 and the second link 55 are pivoted respectively as at 97 and 98 to the cam at different positions on the major axis of the cam face 82.

**[0043]** A roller 87 is supported by a bracket 35 projecting from the bottom wall of the seat 30 so as to be in bearing contact with the cam face 82. The roller 97 rolls along the cam face 82.

**[0044]** When the backrest 20 is reclined from the raised position (FIG. 25) in the chair-type massage machine 10 of the above construction, the second link 55 is pushed out forward, rotating the cam 80 clockwise in FIG. 25.

Since the cam 80 is generally elliptical, the roller 87 in bearing contact with the cam face 82 moves upward along the cam face 82, moving the front end of the seat 30 upward. While the relaxing angle was 109 degree relative to the backrest 20 in the raised position, the seat 30 consequently inclines with increases in the relaxing angle to 113 degree, 116 degree, and 120 degree with an approach to the intermediate position as shown in FIGS. 26 to 28,

**[0045]** When the backrest 20 is brought to the intermediate position, the roller 87 reaches the top of the cam face 82 on the major axis, moving the front end of the seat 30 to the highest level.

The backrest 20 further reclines from this state, rotating the cam 82 to cause the roller 87 to move over the top of the cam face 82 on the major axis. This brings the raised front end of the seat 30 into a downward movement, and when the backrest 20 reclines most greatly, the backrest 20 and the seat 30 are brought to a flat state (at 160 degree as illustrated) as shown in FIG. 29.

**[0046]** According to the present embodiment, modifications of the form of the cam face 82 provide varying relaxing angles.

**[0047]** According to Embodiments 3 to 6, the backrest 20 is reclined by the drive source 42, and this movement is delivered through the link assembly 50, guide rail 60 or cam 80 to pivotally move the seat 30, whereas an actuator serving as the drive source 42 may be interposed between the base 12 and the third link 57 in Embodiments 3 to 5 so as to move the third link 57 about the pivot 95. In Embodiment 6, the cam 80 may be made rotatable by a drive source.

[Industrial Applicability]

**[0048]** The present invention provide useful chair-type massage machines comprising a backrest and a seat which can be reclined by a single drive source while permitting the user to hold a relaxed posture.

**[0049]** Apparently the present invention can be altered or modified by one skilled in the art without departing from the spirit of the invention. Such modifications are included within the scope of the invention as defined in the appended claims.

## Claims

1. A chair-type massage machine comprising a backrest (20) for the back of the user to bear on, a seat (30) for the user to sit in, and a reclining mechanism (40) for pivotally moving the backrest (20) and the seat (30), the massage machine being **characterized in that:**

the reclining mechanism (40) comprises a single drive source (42), the drive source (42) being coupled to the backrest (20) and the seat (30)

by a link assembly (50),

the link assembly (50) being operable to pivotally move the backrest (20) from a raised position to a reclined position via an intermediate position by operating the drive source (42), the seat (30) being tiltable to raise a front end thereof when the backrest (20) is pivotally moved from the raised position to the intermediate position, the seat (30) being tiltable to lower the raised front end thereof when the backrest (20) is pivotally moved from the intermediate position to the reclined position.

2. A chair-type massage machine comprising a backrest (20) for the back of the user to bear on, a seat (30) for the user to sit in, and a reclining mechanism (40) for pivotally moving the backrest (20) and the seat (30), the massage machine being **characterized in that:**

the reclining mechanism (40) comprises a single drive source (42), the drive source (42) being coupled to one of the backrest (20) and the seat (30), the backrest (20) or the seat (30) having the drive source (42) coupled thereto being pivotally movably supported, the backrest (20) being connected to the seat (30) by a link assembly (50) having a joint portion (70), the joint portion (70) of the link assembly being movable along a guide rail (60), the drive source (42) being operable to move the joint portion (70) of the link assembly (50) along the guide rail (60), as coupled to the pivotal movement of the backrest (20) or the seat (30), and to pivotally move the backrest (20) from a raised position to a reclined position via an intermediate position, the guide rail (60) having a curved guide face (62) for tilting the seat (30) to raise a front end thereof when the backrest (20) is pivotally moved from the raised position to the intermediate position and for tilting the seat (30) to lower the raised front end thereof when the backrest (20) is pivotally moved from the intermediate position to the reclined position.

3. A chair-type massage machine wherein a base (12) is provided with a backrest (20) for the back of the user to bear on, a seat (30) for the user to sit in, and a reclining mechanism (40) for pivotally moving the backrest (20) and the seat (30), the massage machine being **characterized in that:**

the reclining mechanism (40) comprises a single drive source (42), the drive source (42) being coupled to one of the backrest (20) and the seat (30), the backrest (20) or the seat (30) having the drive source (42) coupled thereto being pivotally movably supported,

a link (55) being pivoted at one end thereof to the backrest (20) or the seat (30) having the drive source (42) coupled thereto, the link (55) having the other end pivoted to a cam member (80) supported by the base (12), the cam member (80) being provided at a portion thereof with a cam face (82) in bearing contact with the backrest (20) or the seat (30) not coupled to the drive source,  
the drive source (42) being operable to cause the link (55) to rotate the cam member (80) and to pivotally move the backrest (20) from a raised position to a reclined position via an intermediate position, the cam face (82) being so shaped as to tilt the seat (30) to raise a front end thereof when the backrest (20) is pivotally moved from the raised position to the intermediate position and as to tilt the seat (30) to lower the raised front end thereof when the backrest (20) is pivotally moved from the intermediate position to the reclined position.

5

10

15

20

25

30

35

40

45

50

55

FIG. 1

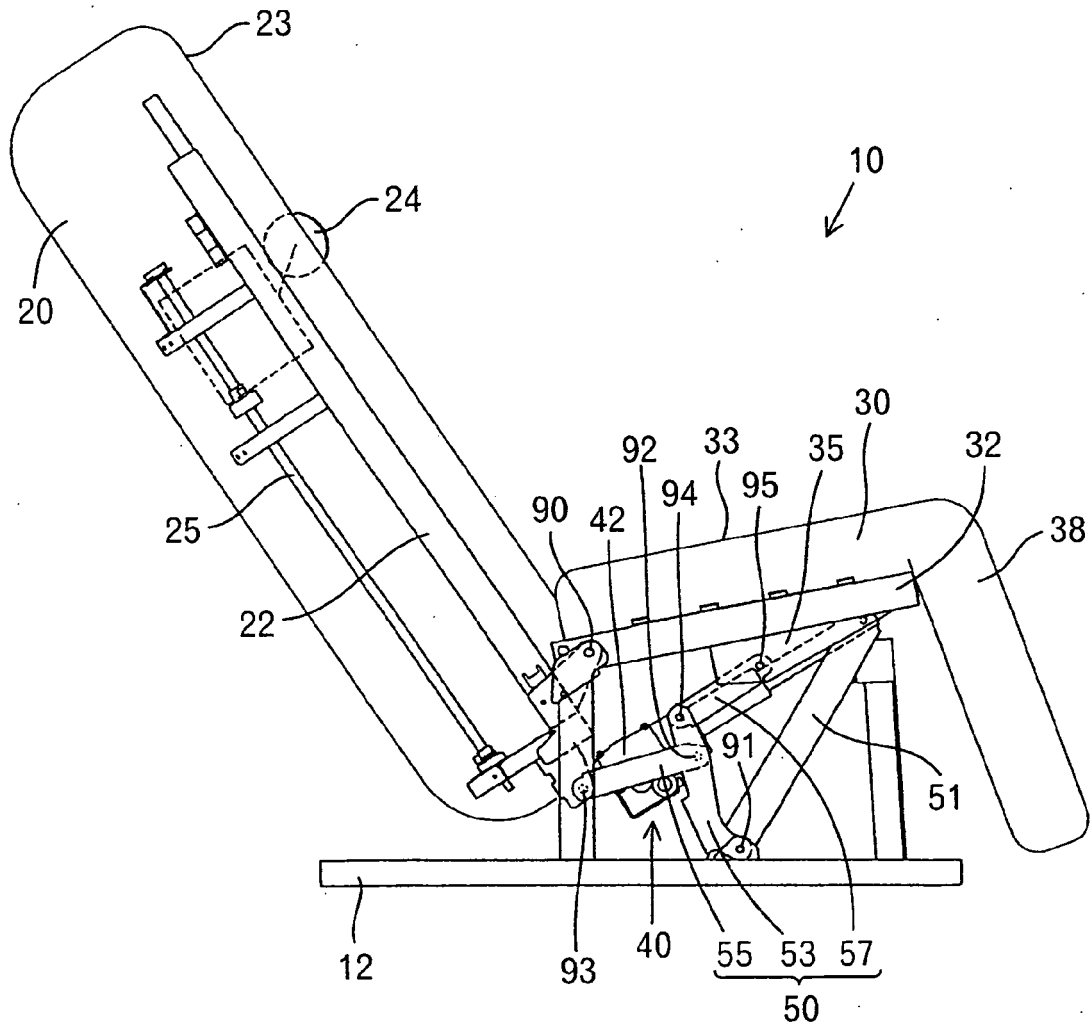

FIG. 2

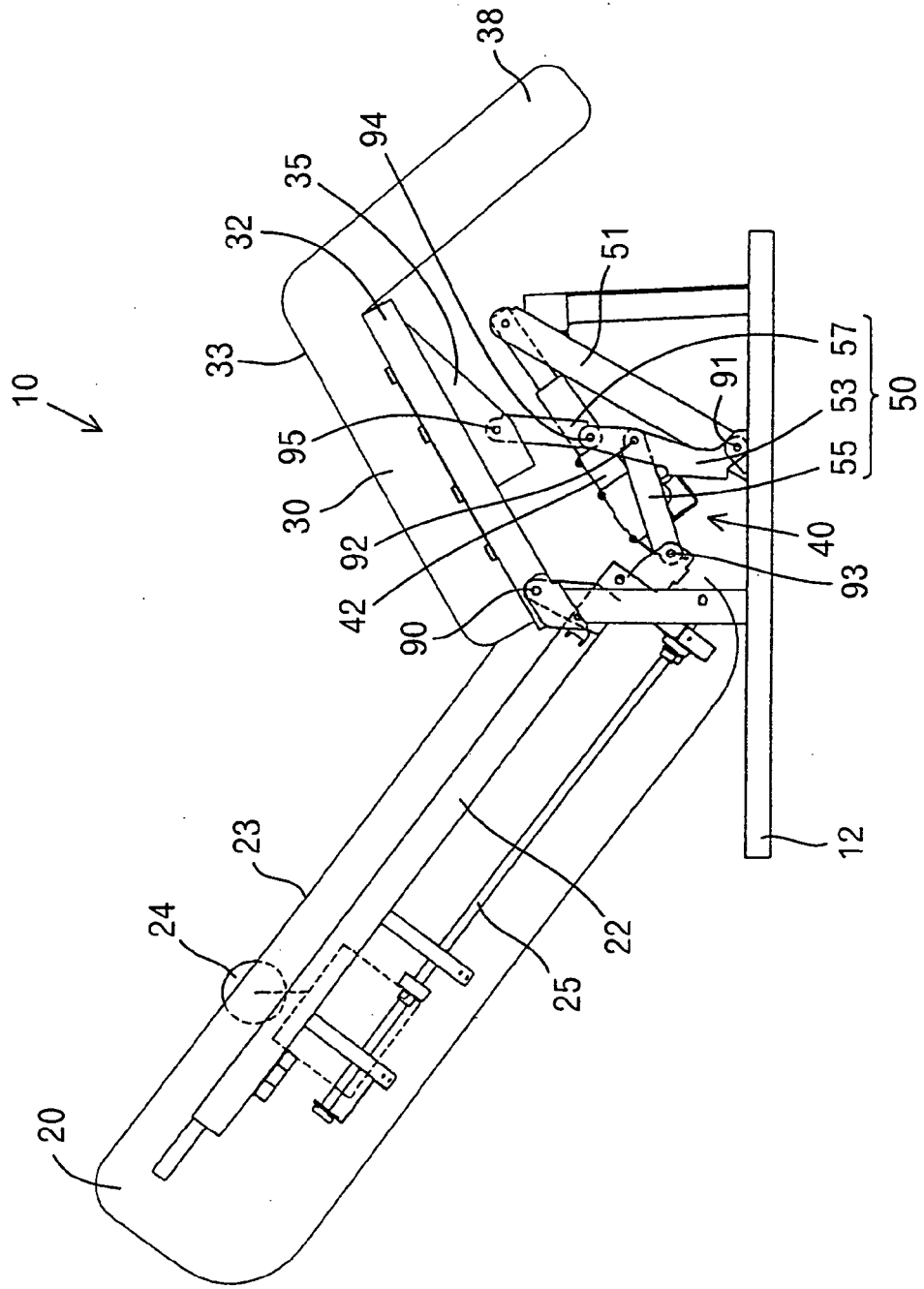

FIG. 3

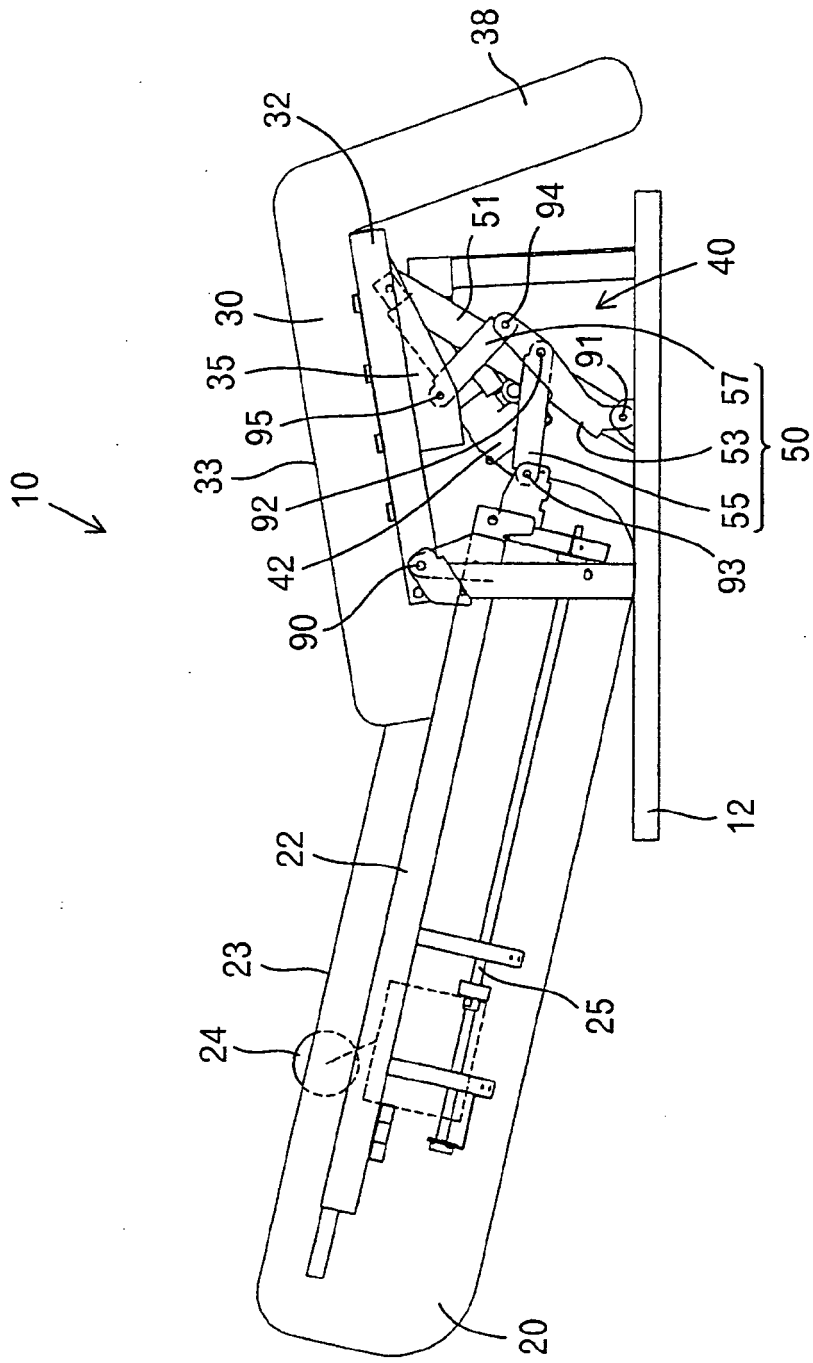

FIG. 4

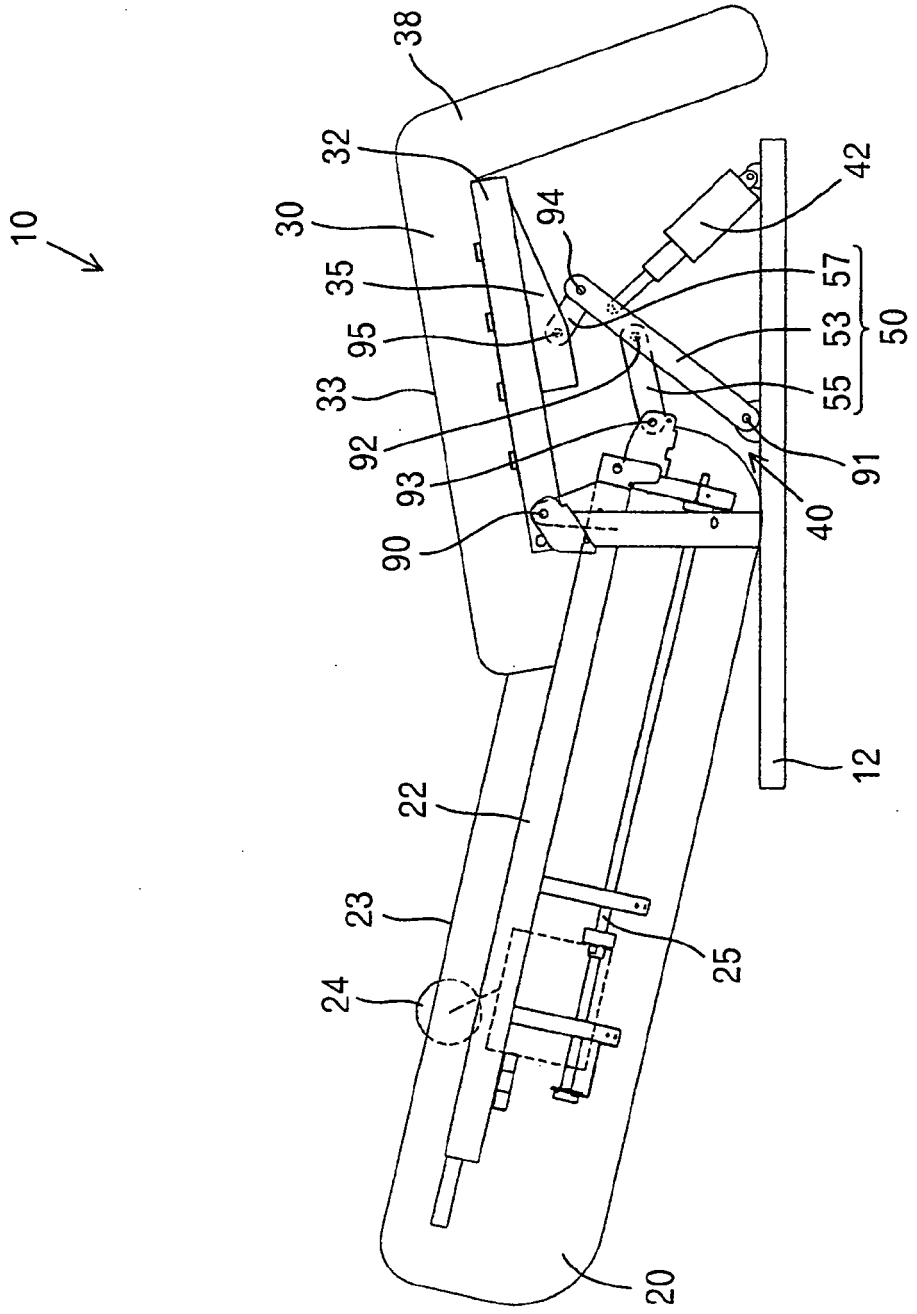

FIG. 5

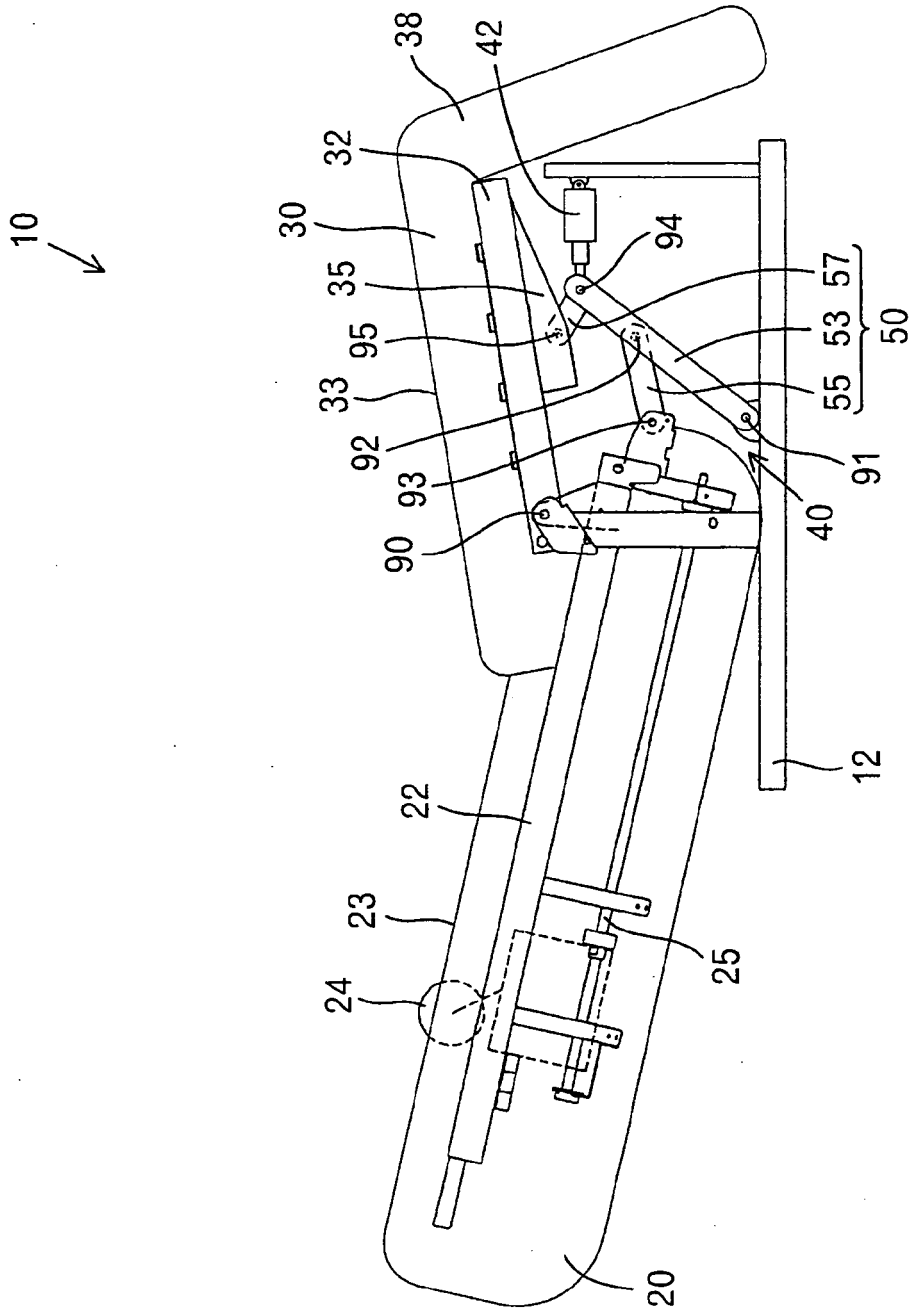

FIG. 6

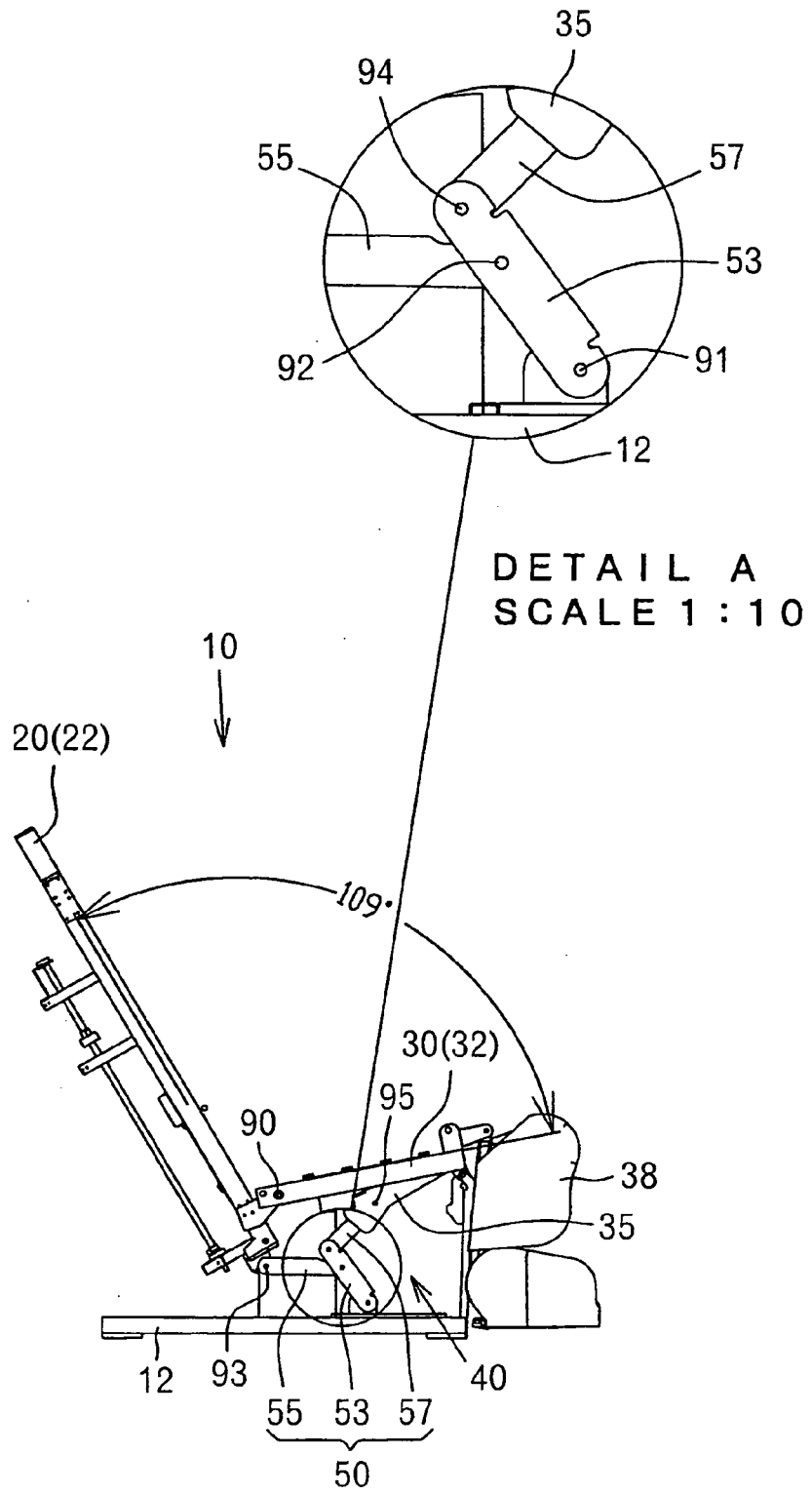

FIG. 7.

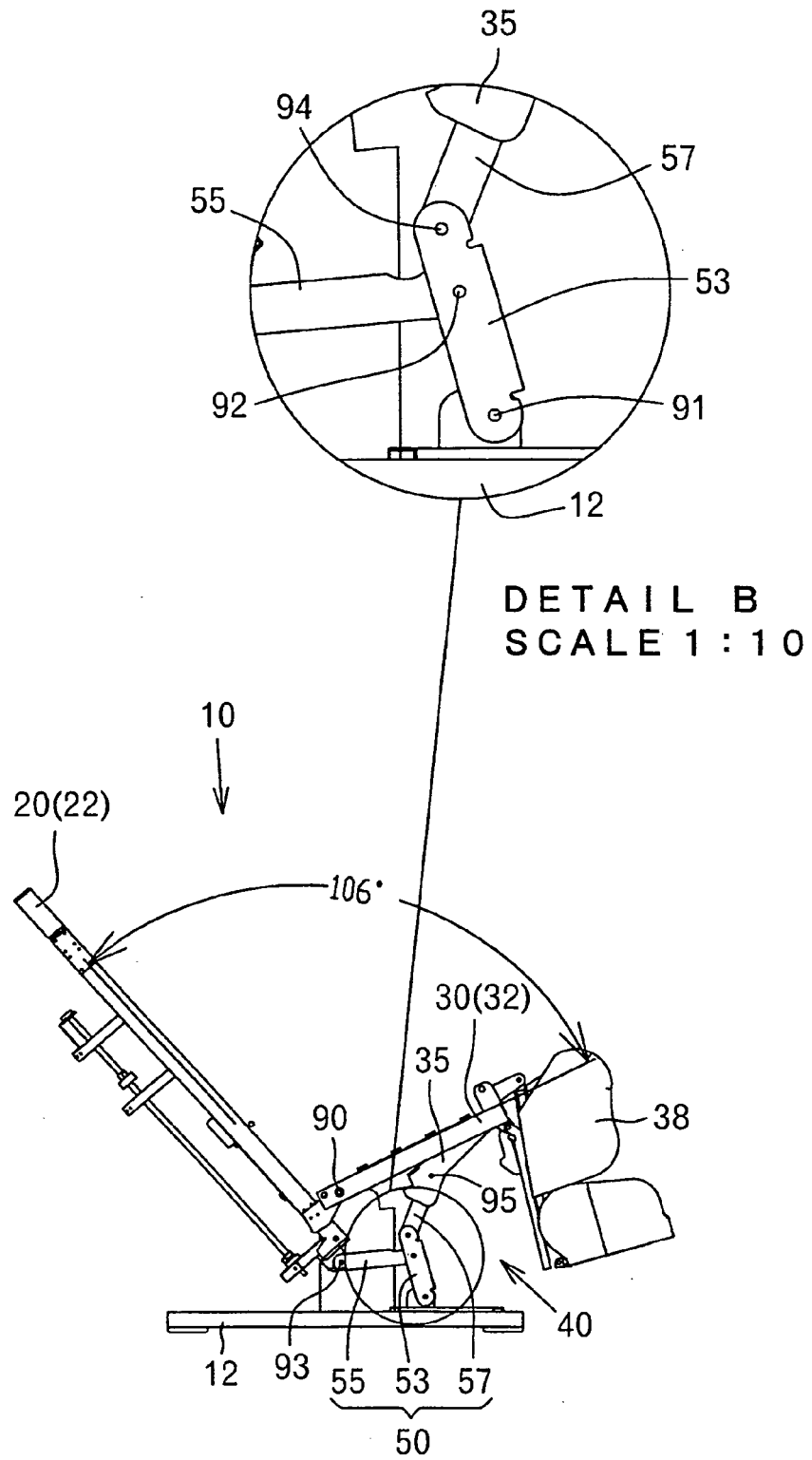

FIG. 8

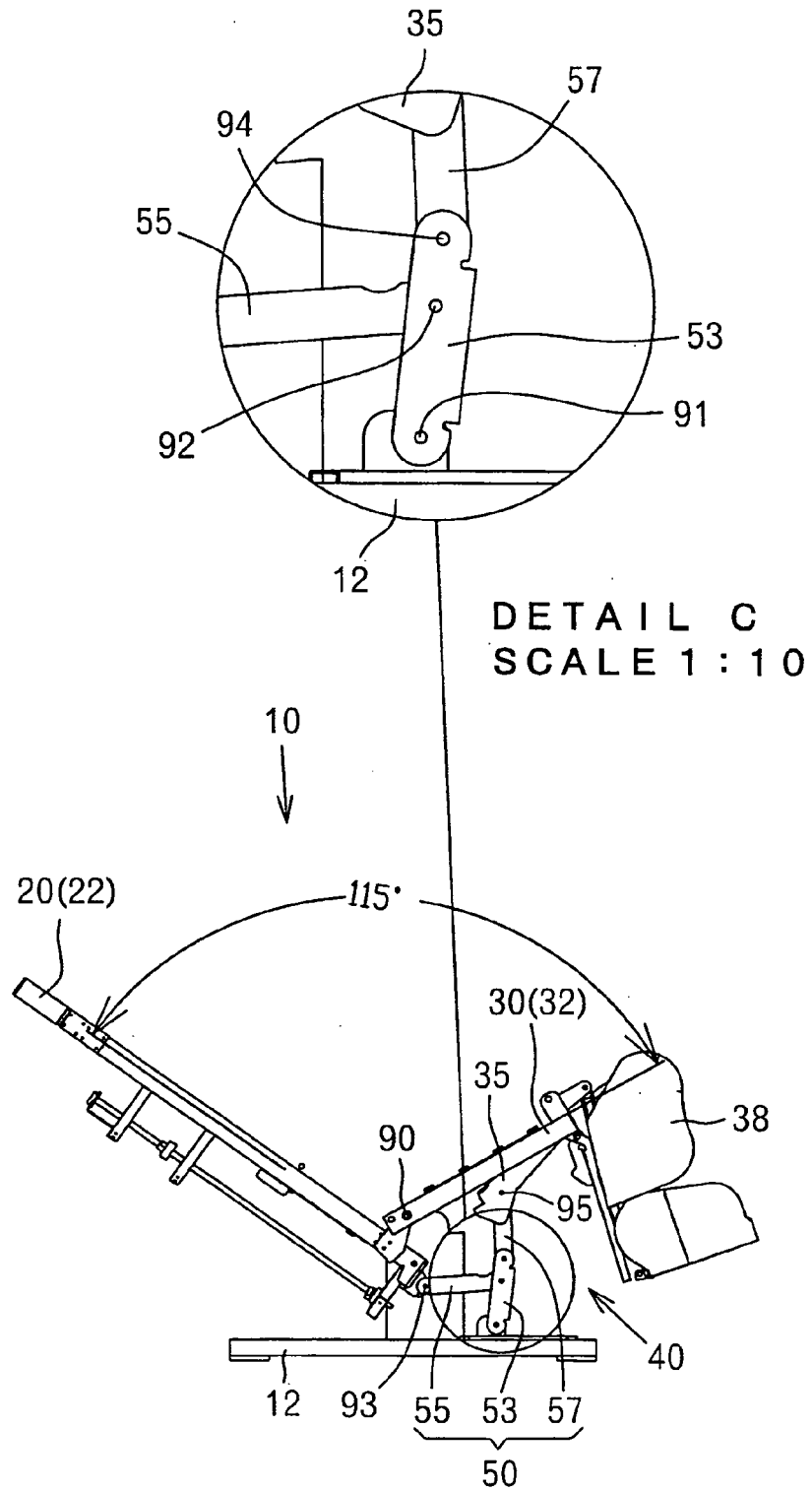

FIG. 9

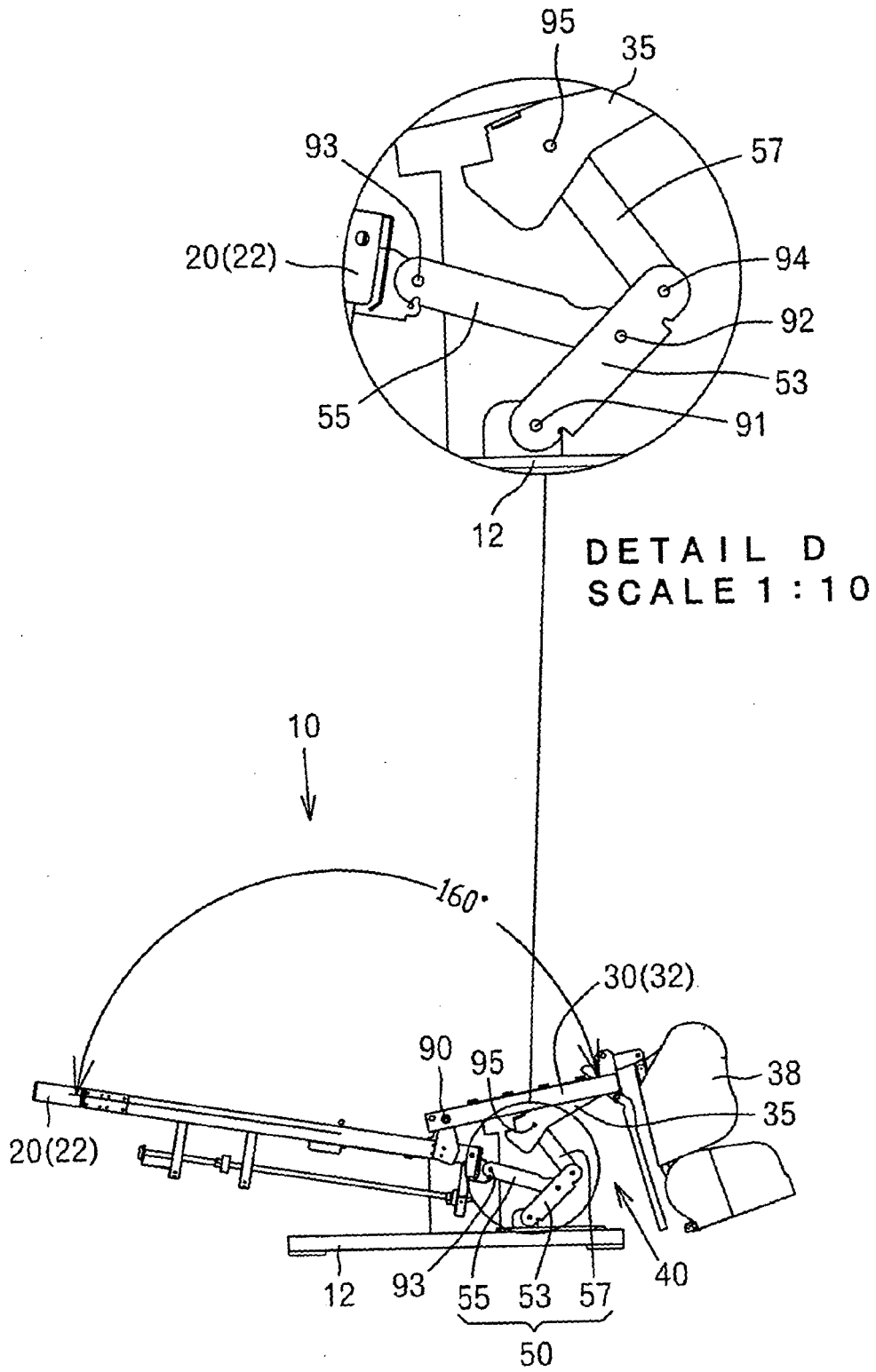

FIG. 10

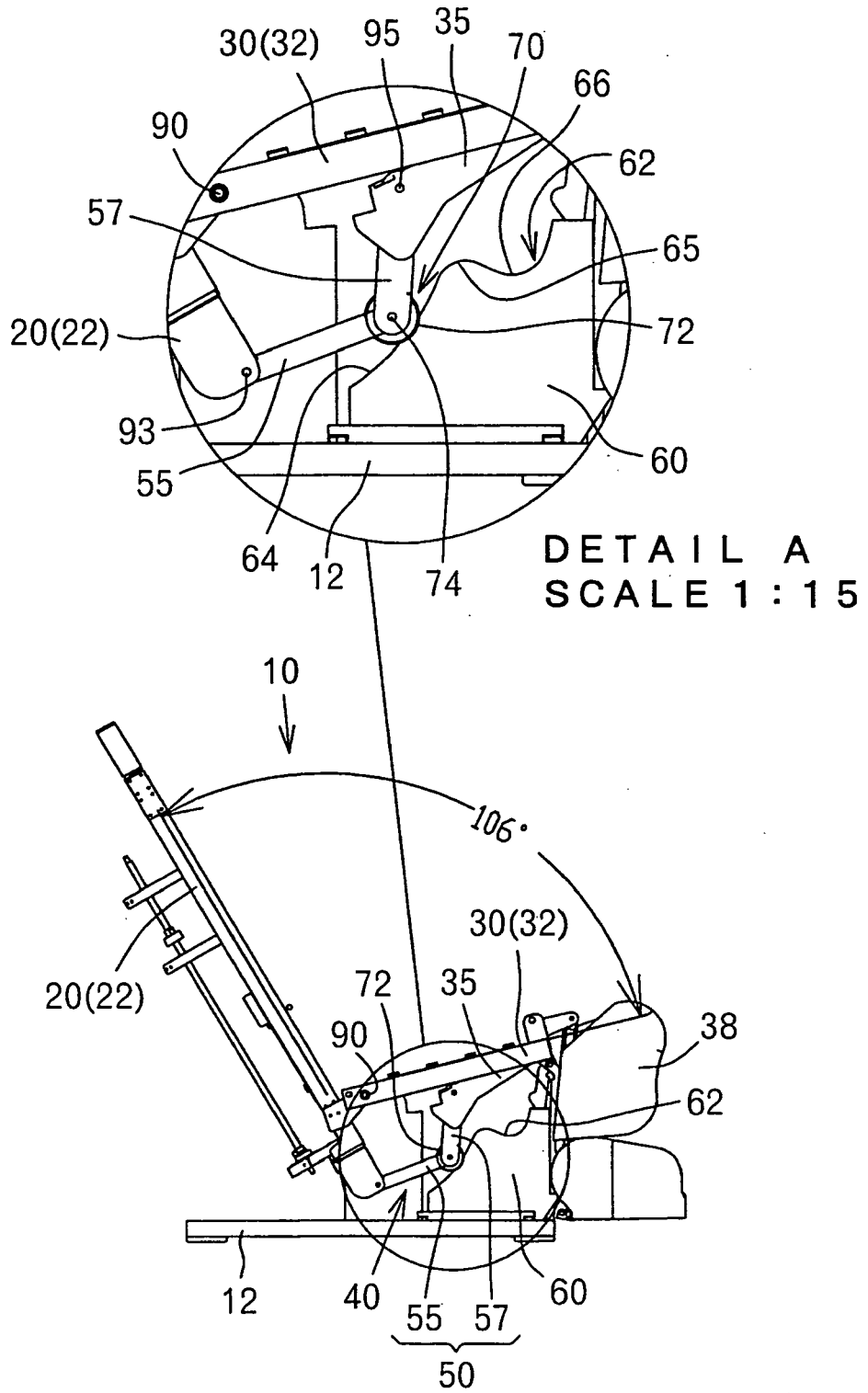

FIG. 11

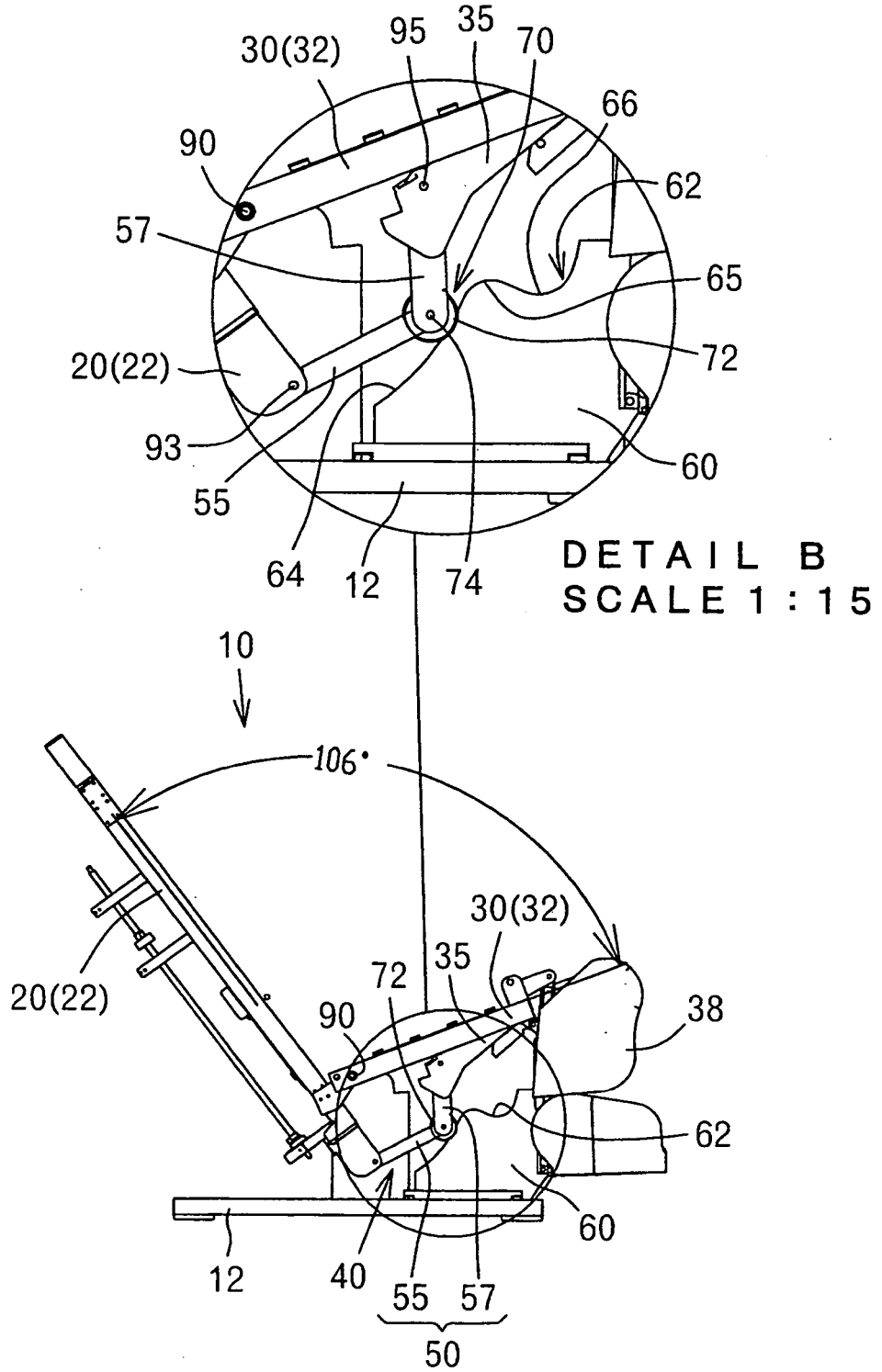

FIG. 12

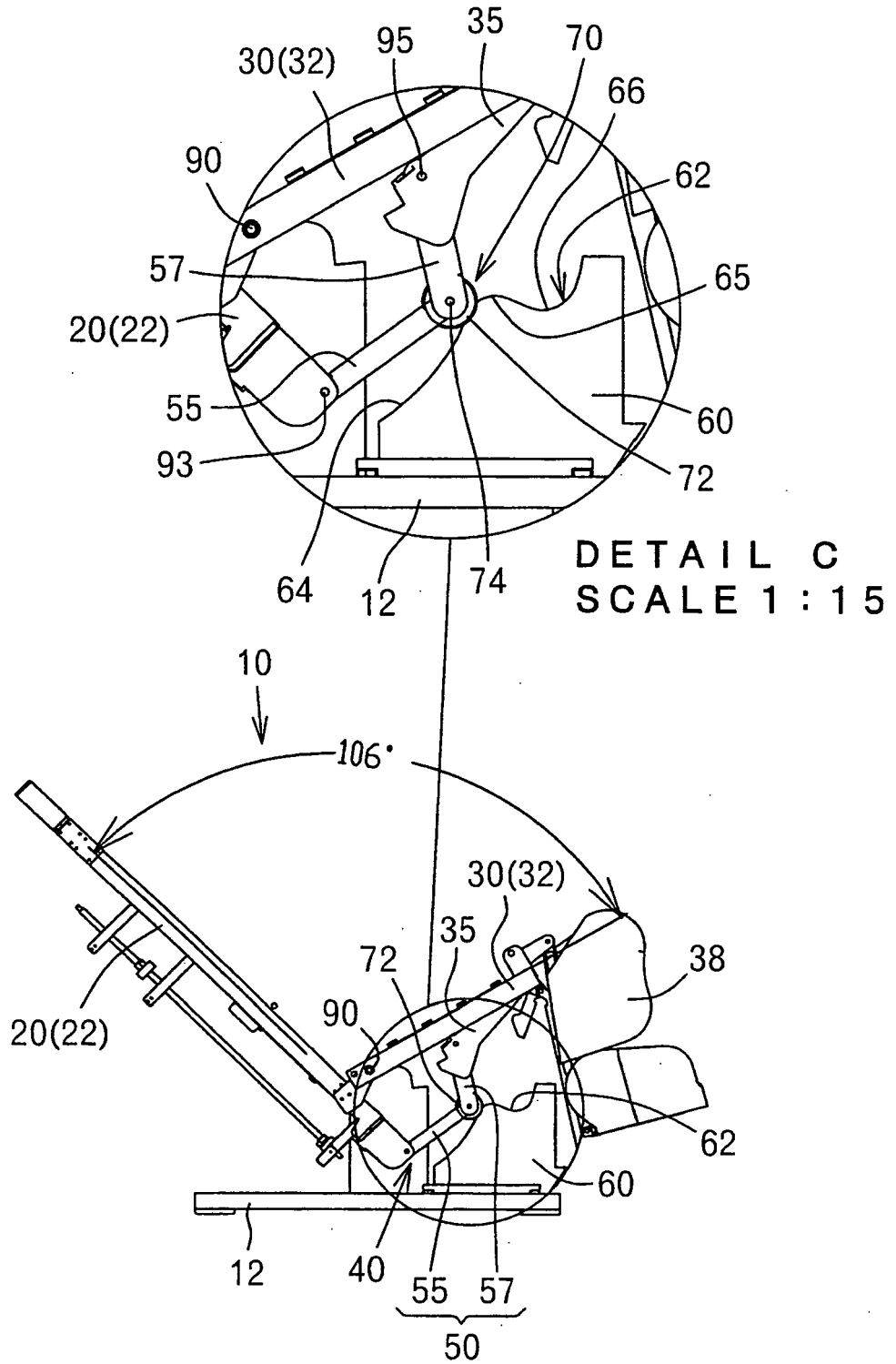

FIG. 13

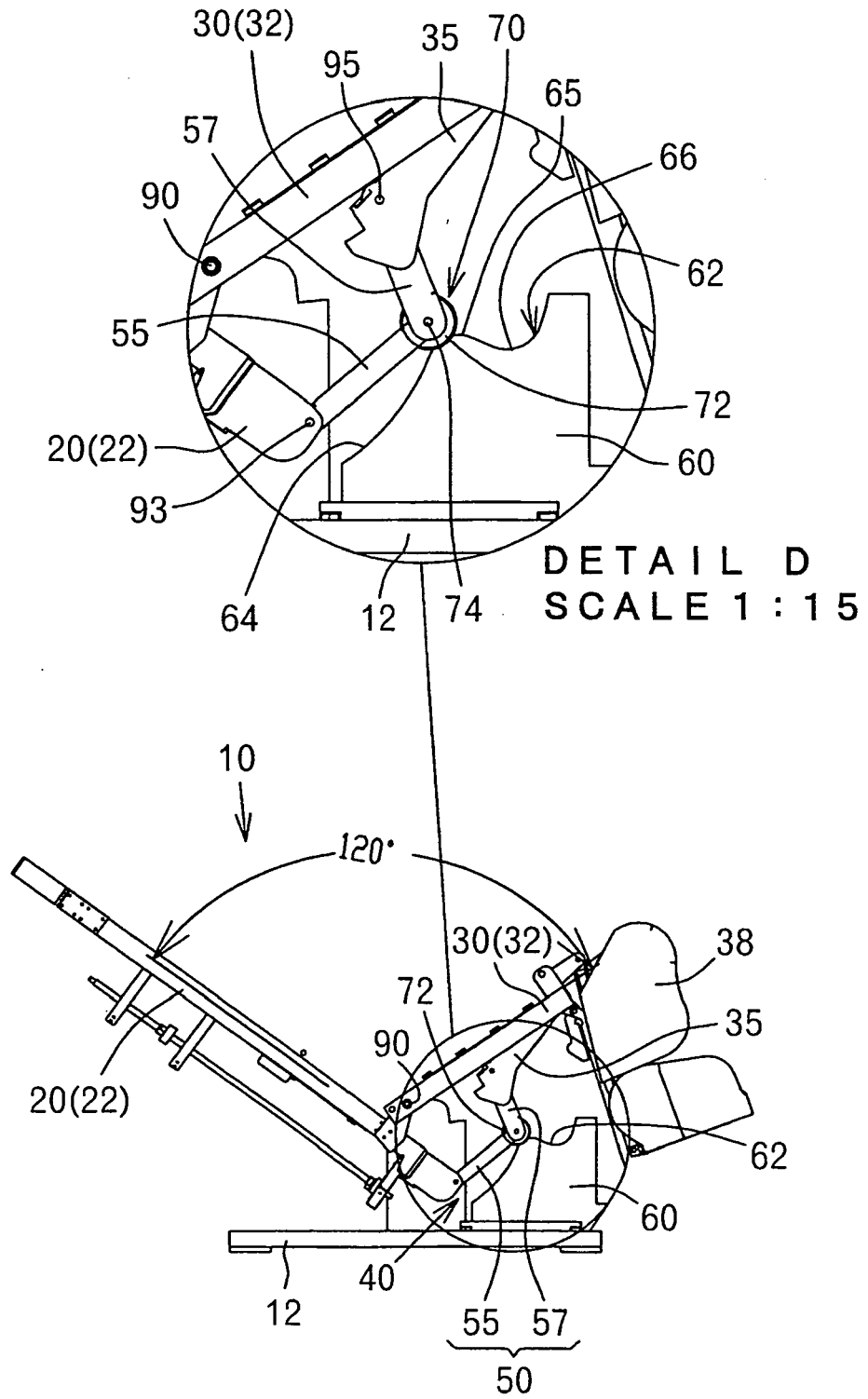

FIG. 14

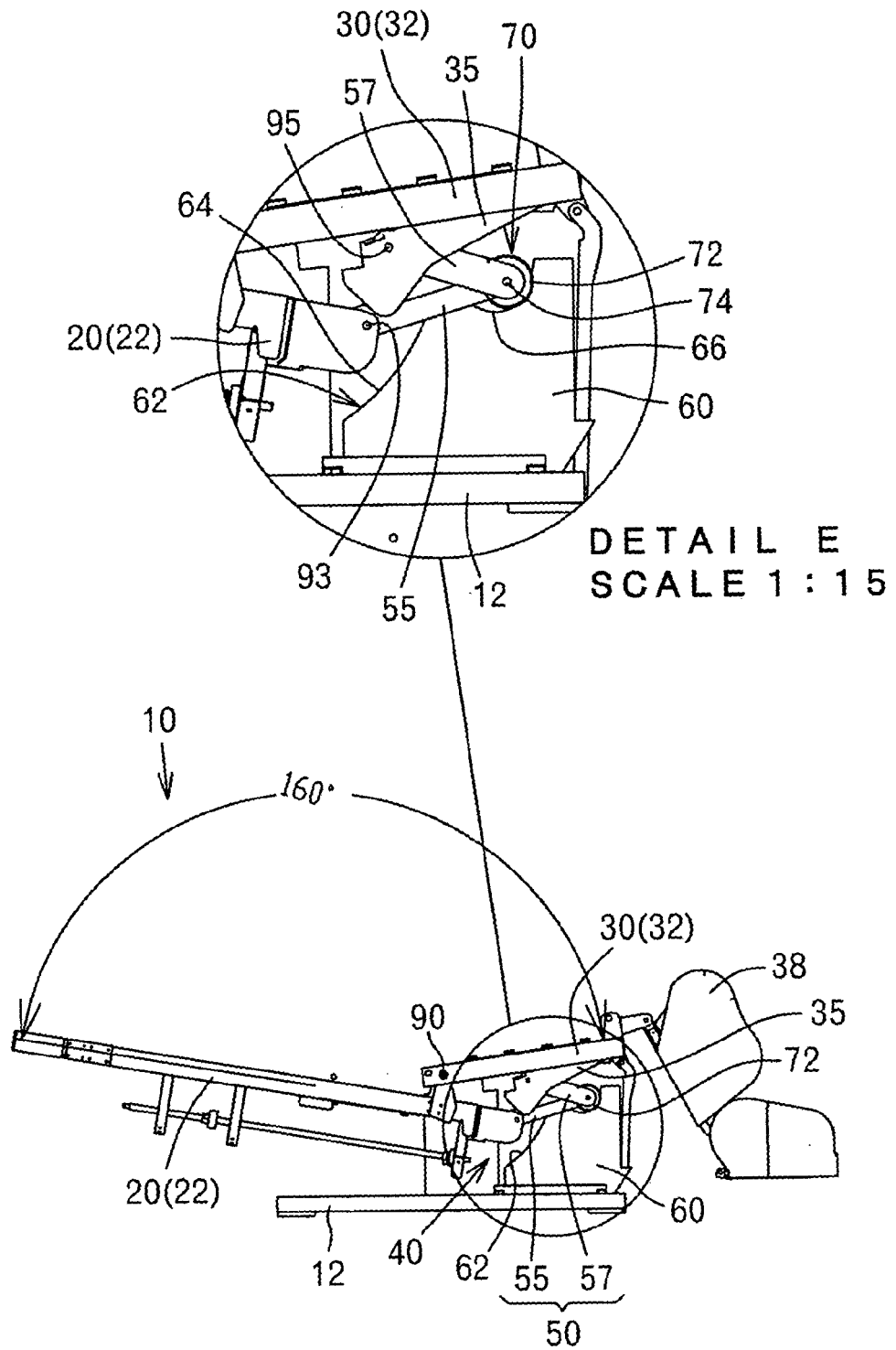

FIG. 15

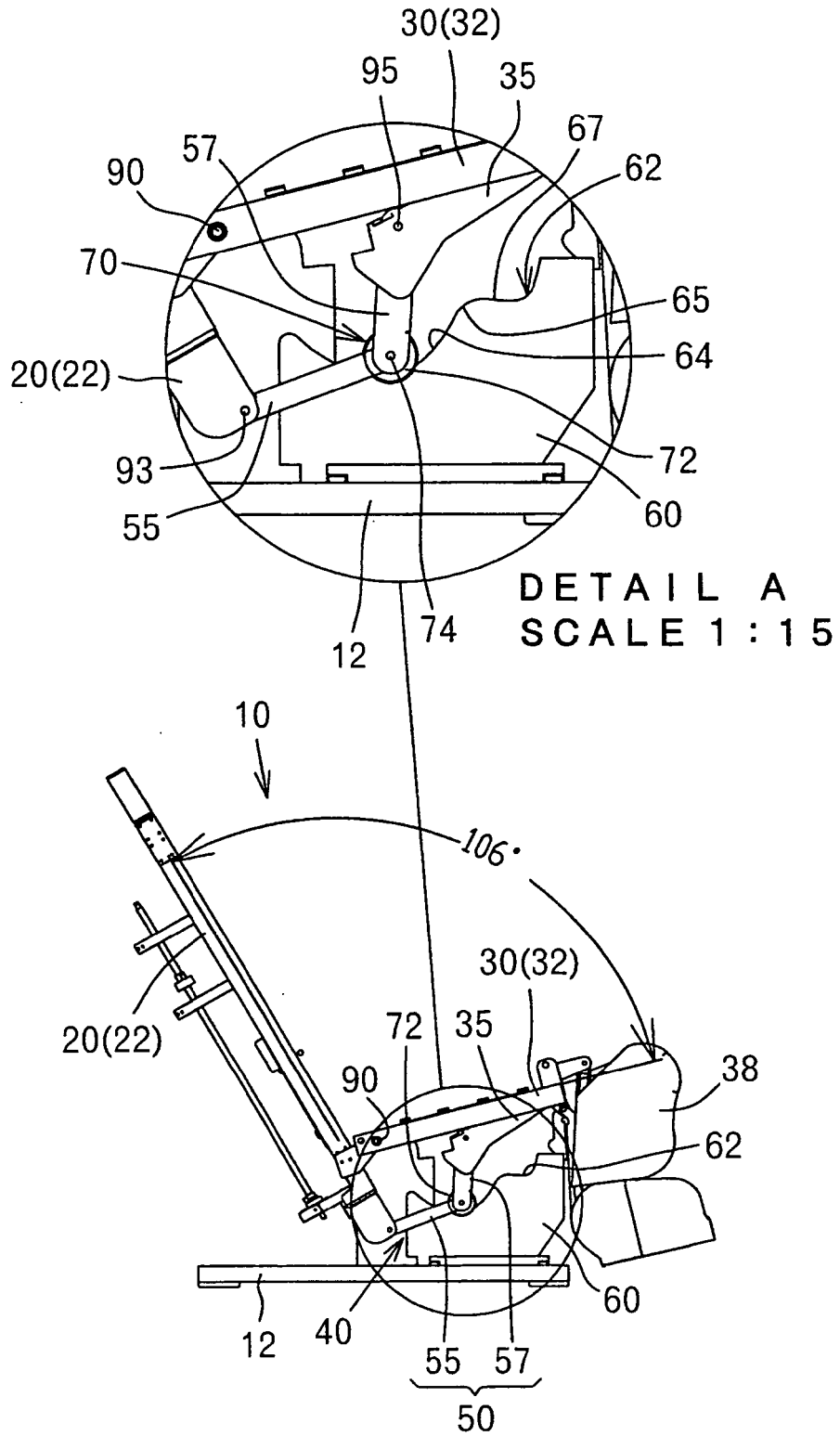

FIG. 16

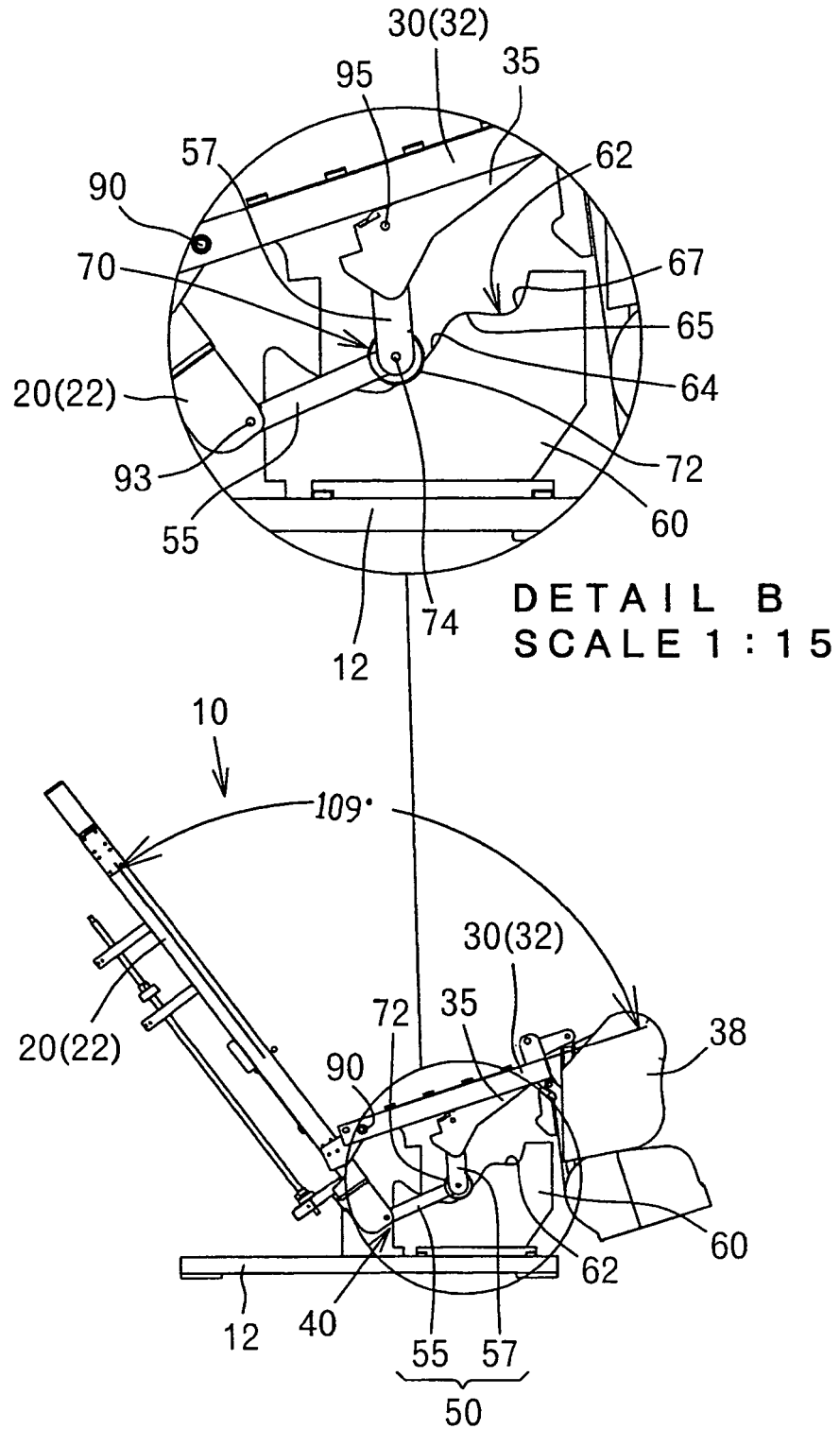

FIG. 17

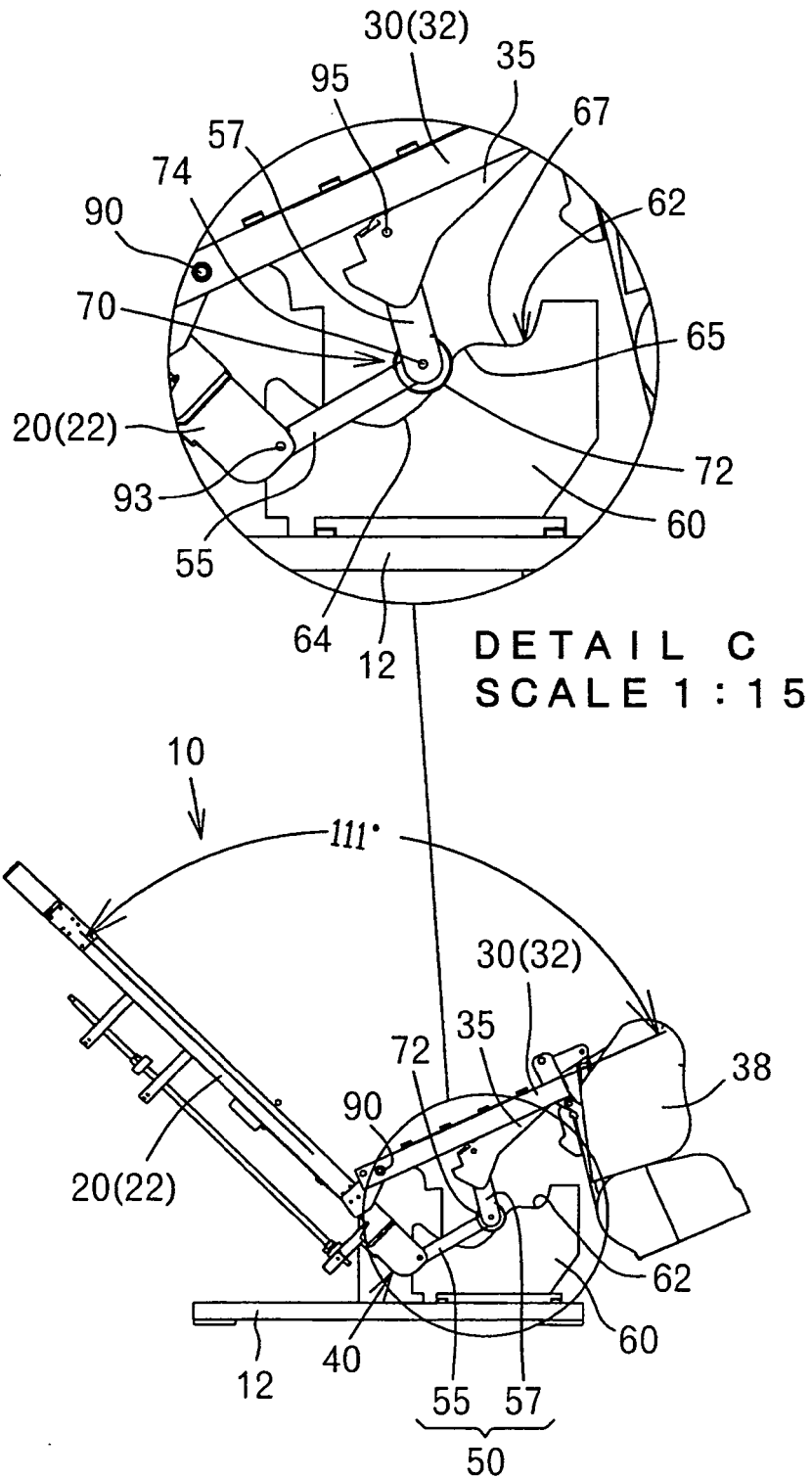

FIG. 18

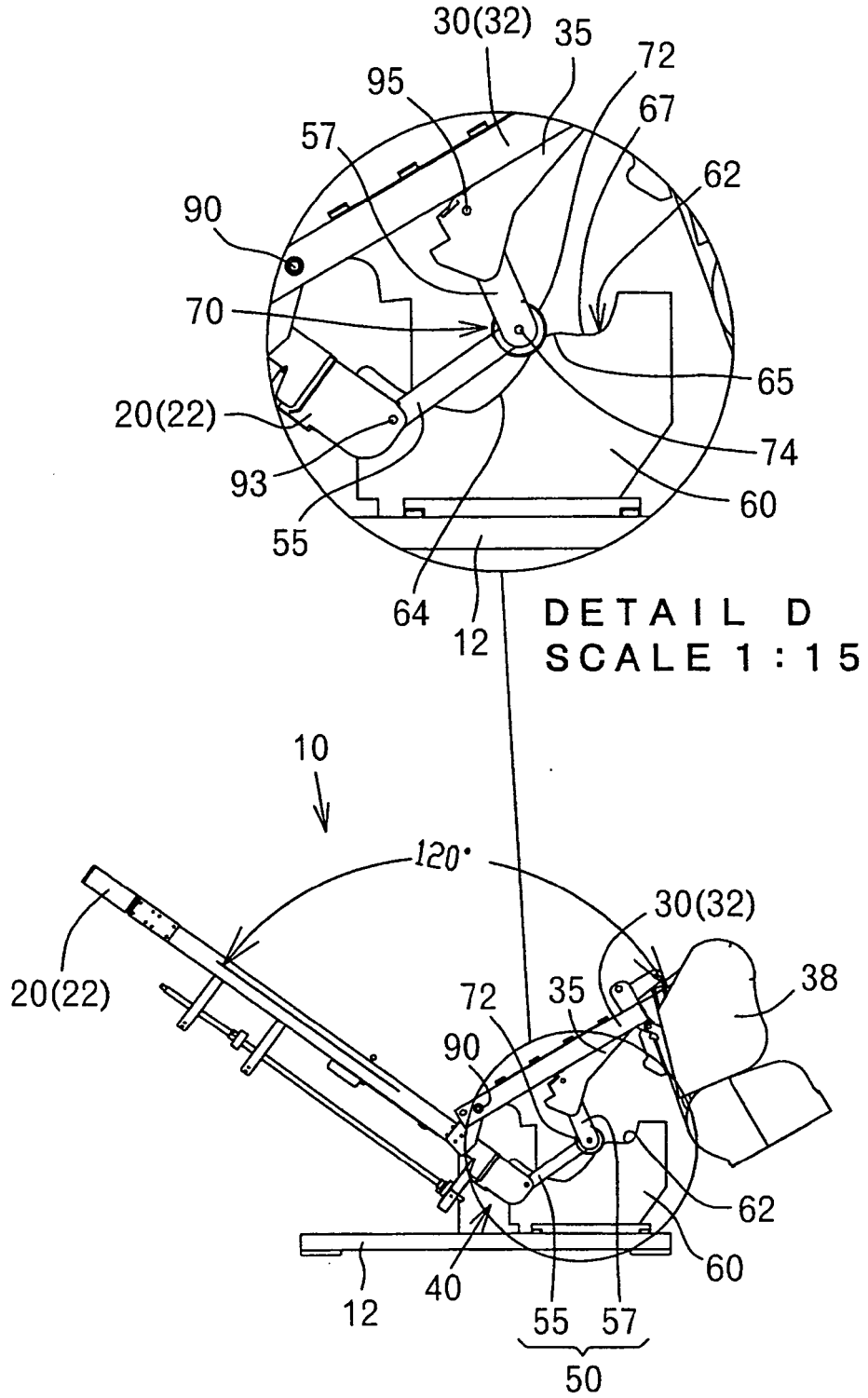

FIG. 19

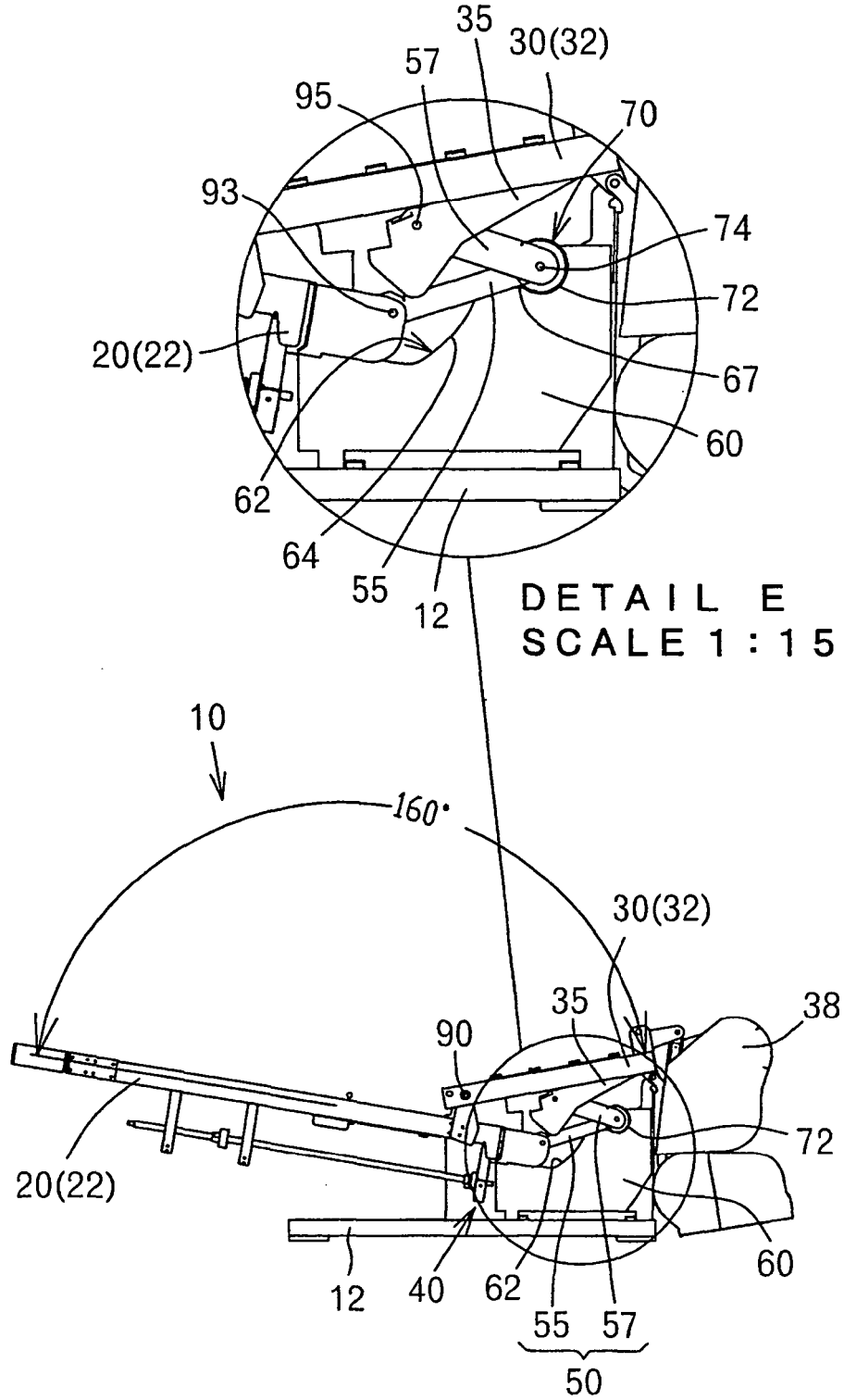

FIG. 20

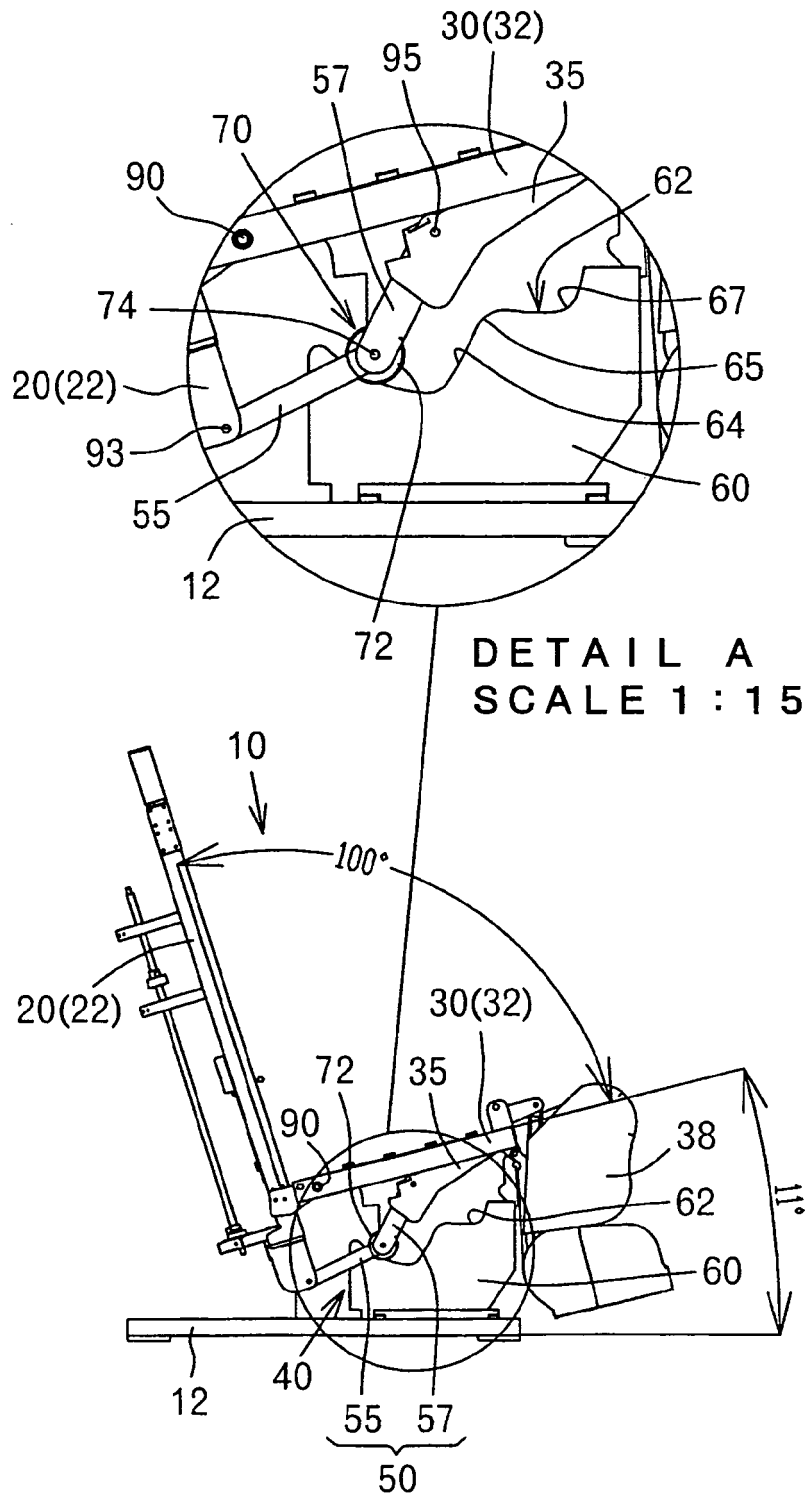

FIG. 21

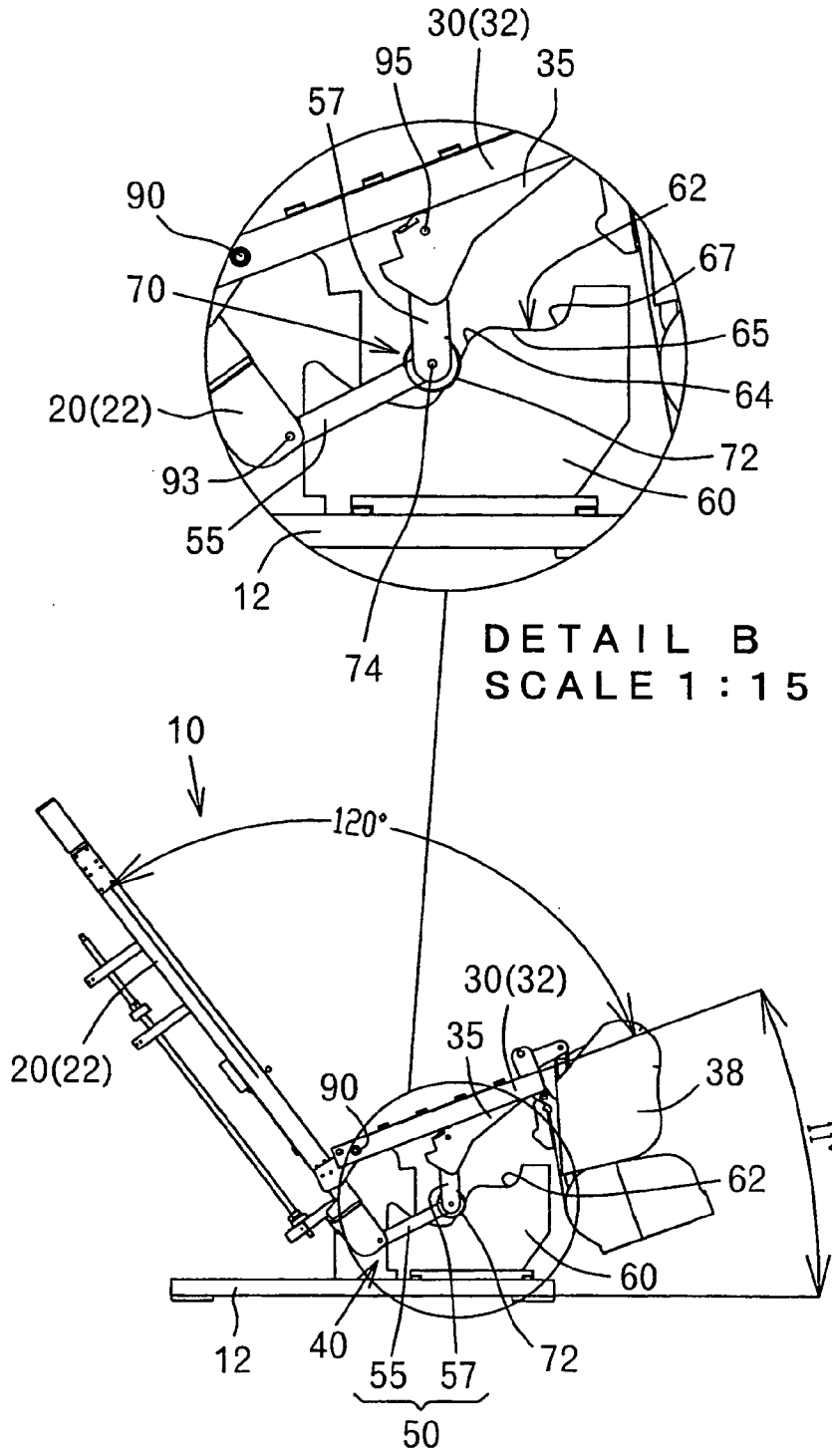



FIG. 23

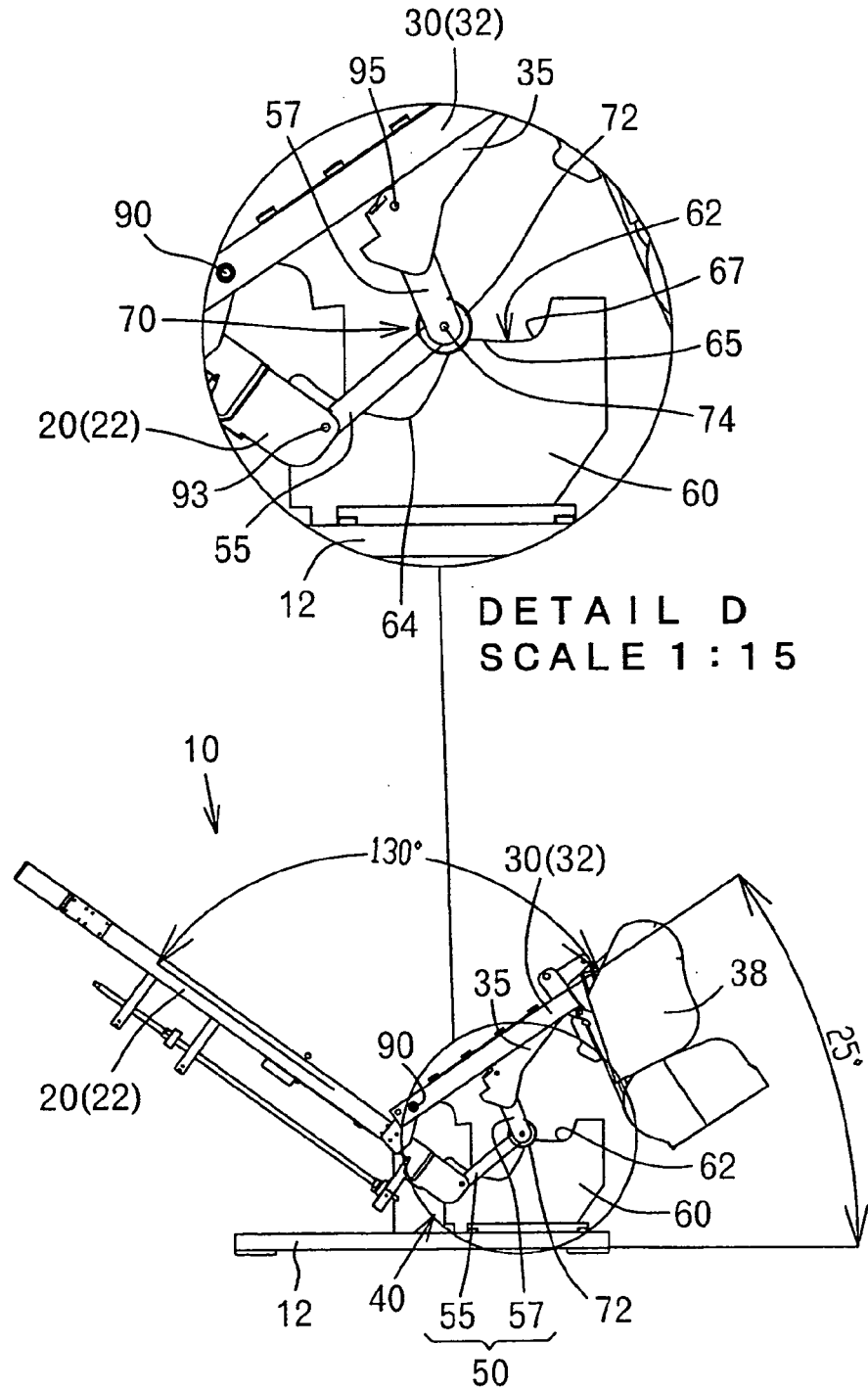

FIG. 24

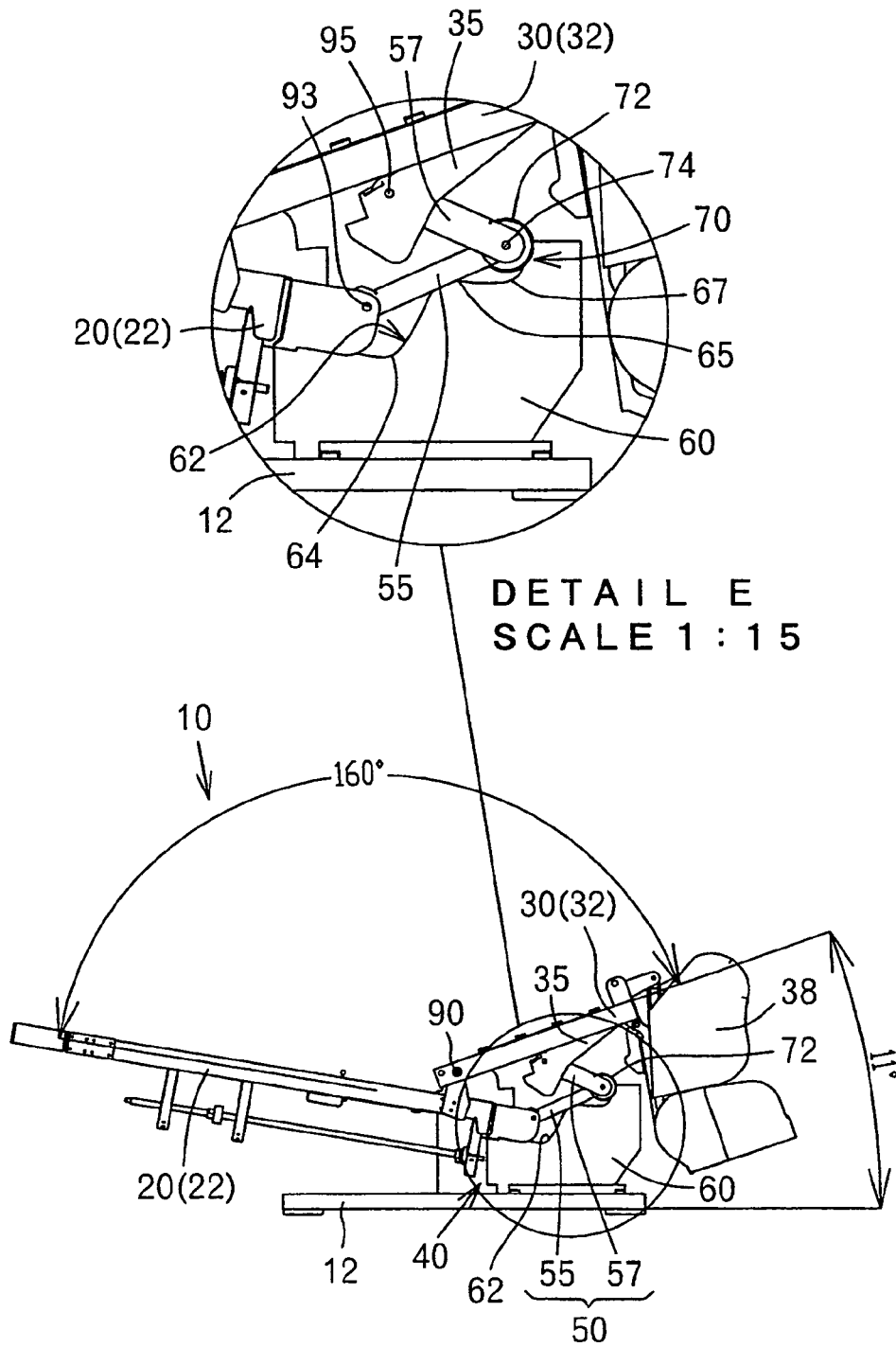

FIG. 25

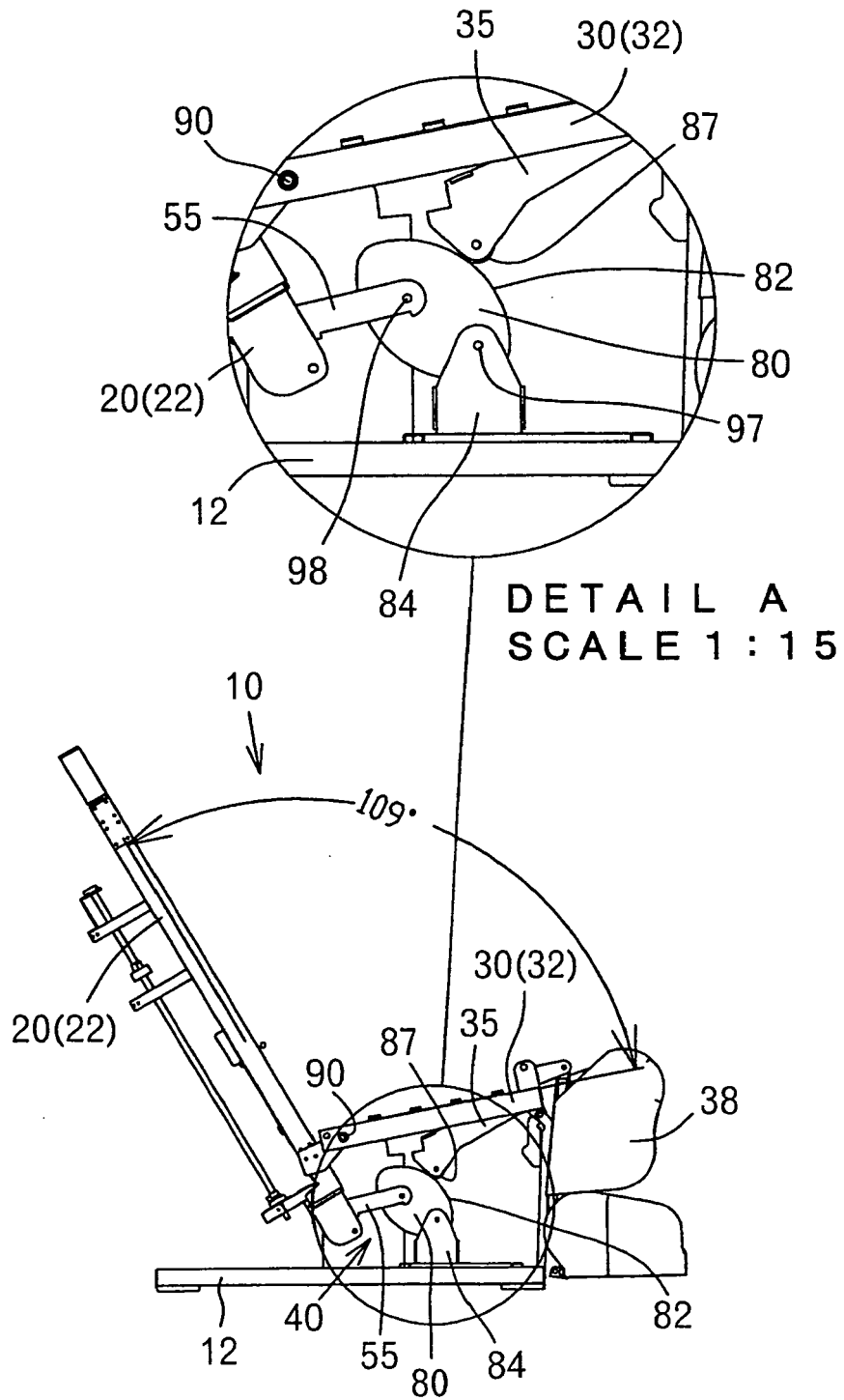

FIG. 26

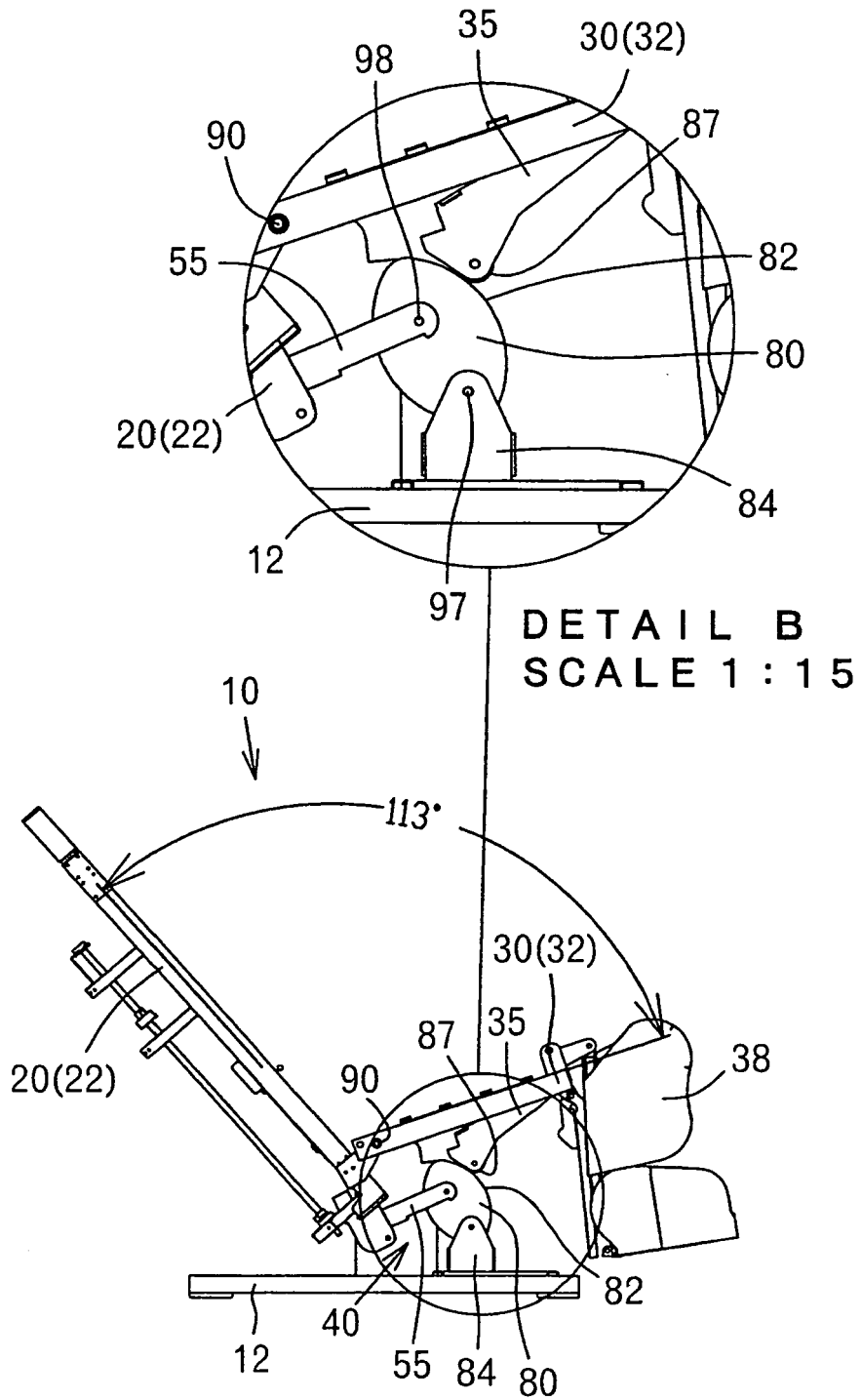

FIG. 27

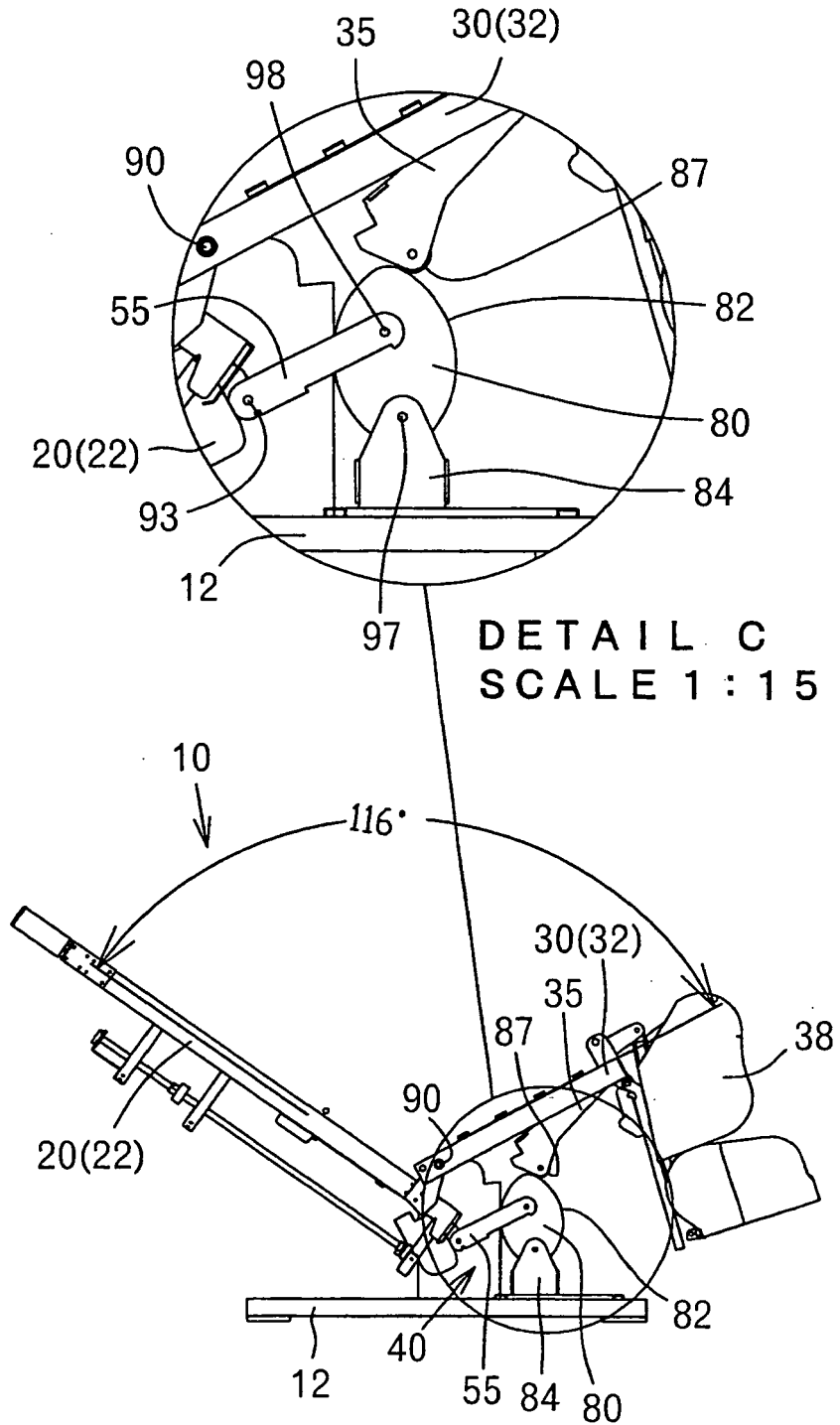
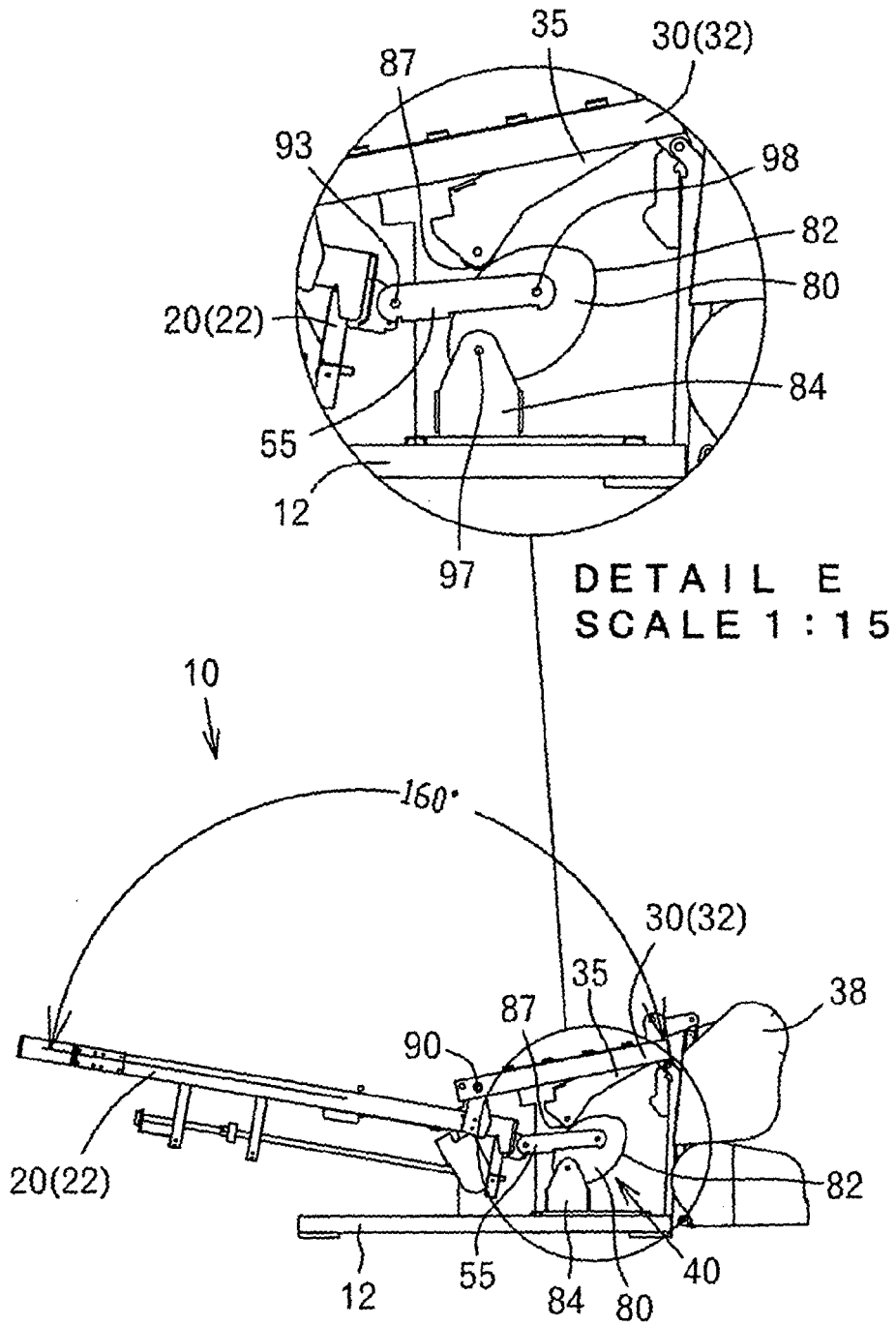



FIG. 29





EUROPEAN SEARCH REPORT

Application Number  
EP 08 01 2969

DOCUMENTS CONSIDERED TO BE RELEVANT			
Category	Citation of document with indication, where appropriate, of relevant passages	Relevant to claim	CLASSIFICATION OF THE APPLICATION (IPC)
X	US 2007/120408 A1 (HSIEH WEN-HSU [TW]) 31 May 2007 (2007-05-31) * abstract; figures *	1	INV. A47C1/02
X	US 6 390 546 B1 (MING LIAO TSUNG [TW]) 21 May 2002 (2002-05-21) * abstract; figures *	1	
X	DE 199 26 011 A1 (FUJI IRYOKI OSAKA KK [JP]) 14 December 2000 (2000-12-14) * abstract; figures *	1	
X	EP 0 361 302 A (WHITESUN SPA [IT]) 4 April 1990 (1990-04-04) * abstract; figures *	1	
X	US 6 974 186 B1 (CHANG HORNG J [TW] CHANG HORNG JIUN [TW]) 13 December 2005 (2005-12-13) * abstract; figures *	1	
			TECHNICAL FIELDS SEARCHED (IPC)
			A47C A61H
The present search report has been drawn up for all claims			
Place of search		Date of completion of the search	Examiner
Munich		10 October 2008	MacCormick, Duncan
CATEGORY OF CITED DOCUMENTS			
X : particularly relevant if taken alone Y : particularly relevant if combined with another document of the same category A : technological background O : non-written disclosure P : intermediate document		T : theory or principle underlying the invention E : earlier patent document, but published on, or after the filing date D : document cited in the application L : document cited for other reasons & : member of the same patent family, corresponding document	

2  
EPO FORM 1503 03.82 (P04C01)

**ANNEX TO THE EUROPEAN SEARCH REPORT  
ON EUROPEAN PATENT APPLICATION NO.**

EP 08 01 2969

This annex lists the patent family members relating to the patent documents cited in the above-mentioned European search report. The members are as contained in the European Patent Office EDP file on The European Patent Office is in no way liable for these particulars which are merely given for the purpose of information.

10-10-2008

Patent document cited in search report		Publication date	Patent family member(s)	Publication date
US 2007120408	A1	31-05-2007	NONE	
-----				
US 6390546	B1	21-05-2002	NONE	
-----				
DE 19926011	A1	14-12-2000	NONE	
-----				
EP 0361302	A	04-04-1990	IT 1225701 B	22-11-1990
			US 5086769 A	11-02-1992
-----				
US 6974186	B1	13-12-2005	NONE	
-----				

EPC FORM P0459

For more details about this annex : see Official Journal of the European Patent Office, No. 12/82

**REFERENCES CITED IN THE DESCRIPTION**

*This list of references cited by the applicant is for the reader's convenience only. It does not form part of the European patent document. Even though great care has been taken in compiling the references, errors or omissions cannot be excluded and the EPO disclaims all liability in this regard.*

**Patent documents cited in the description**

- JP 2003289975 A [0002]