

(19) World Intellectual Property Organization
International Bureau



(43) International Publication Date
6 March 2008 (06.03.2008)

PCT

(10) International Publication Number
WO 2008/028107 A2

(51) International Patent Classification:
A61B 1/04 (2006.01)

(21) International Application Number:
PCT/US2007/077350

(22) International Filing Date: 31 August 2007 (31.08.2007)

(25) Filing Language: English

(26) Publication Language: English

(30) Priority Data:
60/841,593 31 August 2006 (31.08.2006) US

(71) Applicant (for all designated States except US): **WILSON-COOK MEDICAL, INC.** [US/US]; 4900 Bethania Station Road, P.O. Box 4191, Winston-salem, NC 27105 (US).

(72) Inventor; and

(75) Inventor/Applicant (for US only): **JONES, Brian, K.** [US/—]; P.o. Box 6833, Spartanburg, SC 29306 (US).

(74) Agents: **MILZ, Michael, E.** et al.; Brinks Hofer Gilson & Lione, P.O. Box 10087, Chicago, IL 60610 (US).

(81) Designated States (unless otherwise indicated, for every kind of national protection available): AE, AG, AL, AM, AT, AU, AZ, BA, BB, BG, BH, BR, BW, BY, BZ, CA, CH, CN, CO, CR, CU, CZ, DE, DK, DM, DO, DZ, EC, EE, EG, ES, FI, GB, GD, GE, GH, GM, GT, HN, HR, HU, ID, IL, IN, IS, JP, KE, KG, KM, KN, KP, KR, KZ, LA, LC, LK, LR, LS, LT, LU, LY, MA, MD, ME, MG, MK, MN, MW, MX, MY, MZ, NA, NG, NI, NO, NZ, OM, PG, PH, PL, PT, RO, RS, RU, SC, SD, SE, SG, SK, SL, SM, SV, SY, TJ, TM, TN, TR, TT, TZ, UA, UG, US, UZ, VC, VN, ZA, ZM, ZW.

(84) Designated States (unless otherwise indicated, for every kind of regional protection available): ARIPO (BW, GH, GM, KE, LS, MW, MZ, NA, SD, SL, SZ, TZ, UG, ZM, ZW), Eurasian (AM, AZ, BY, KG, KZ, MD, RU, TJ, TM), European (AT, BE, BG, CH, CY, CZ, DE, DK, EE, ES, FI, FR, GB, GR, HU, IE, IS, IT, LT, LU, LV, MC, MT, NL, PL, PT, RO, SE, SI, SK, TR), OAPI (BF, BJ, CF, CG, CI, CM, GA, GN, GQ, GW, ML, MR, NE, SN, TD, TG).

Published:
— without international search report and to be republished upon receipt of that report

(54) Title: FIBERSCOPE INTERFACING APPARATUS FOR ENDOSCOPIC PROCEDURES

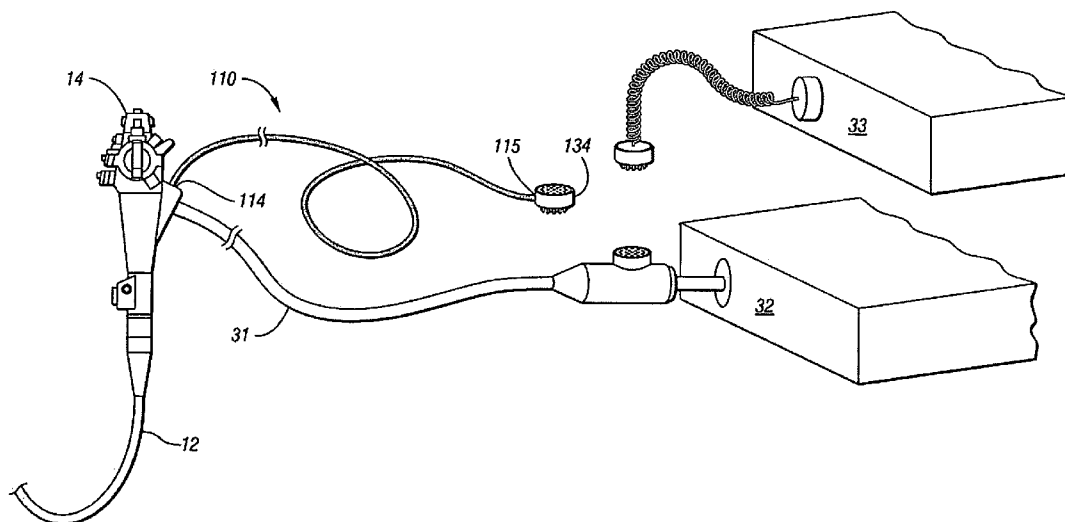

(57) Abstract: A fiberscope interfacing apparatus for an endoscope system insertable in a body cavity is disclosed. The apparatus comprises an elongate communication medium having a first end and a second end for transmitting an optical signal of an image of the body cavity. The apparatus further comprises a lens attached to the first end of the communication medium for receiving the optical signal from the body cavity. The lens is in communication with the communication medium. The apparatus further comprises an interface collar attached to the second end of the communication medium and is in communication therewith. The interface collar is configured to communicate with the endoscope system and transfer the optical signal thereto for simultaneous fiber optic imaging and fluoroscopic imaging.



WO 2008/028107 A2

FIBERSCOPE INTERFACING APPARATUS FOR ENDOSCOPIC PROCEDURES

CROSS-REFERENCE TO RELATED APPLICATIONS

[0001] This application claims the benefit of U.S. Provisional Application serial no. 60/841,593 filed on August 31, 2006, entitled "FIBERSCOPE INTERFACING APPARATUS FOR ENDOSCOPIC PROCEDURES," the entire contents of which are incorporated herein by reference.

FIELD OF THE INVENTION

[0002] The present invention relates to medical devices and more particularly to fiberscope interfacing apparatus for endoscopic procedures.

BACKGROUND OF THE INVENTION

[0003] There have been recent advancements of minimally-invasive surgical procedures involving endoscopes. Such procedures have proven to be advantageous alternatives over prior invasive surgical procedures. Such advantages include quicker recovery time as well as more efficient hospital stays and medical costs.

[0004] Endoscopic devices have been commonly used for various procedures, typically in the abdominal area. Endoscopy is the examination and inspection of the interior of body organs, joints or cavities through an endoscope. Endoscopy allows physicians to peer through the body's passageways. An endoscopic procedure may be used to diagnose various conditions by close examination of internal organ and body structures and may also guide therapy and repair, such as the removal of torn cartilage from the bearing surfaces of a joint. A biopsy, a procedure involving tissue sampling for pathologic testing, may also be

performed under endoscopic guidance. For example, endoscopic procedures include the following known procedures: gastroscopy, sigmoidoscopy and colonoscopy, esophago gastro duodenoscopy (EGD), endoscopic retrograde cholangiopancreatography (ERCP), and bronchoscopy.

[0005] Although adequate, many devices and procedures may be enhanced. For example, there is a need to enhance viewing and viewing efficiency during fluoroscopic and endoscopic procedures. Typically, fluoroscopy is performed separate from an endoscopic procedure. The series of procedures or diagnosis results in extra time involved to complete the diagnosis. Thus, there is a need to enhance imaging features within a body cavity or vessel during endoscopic and fluoroscopic procedures.

BRIEF SUMMARY OF THE INVENTION

[0006] The present invention generally provides a way of enhancing imaging analysis of the internal structures of a patient during an endoscopic and fluoroscopic procedure.

[0007] In one embodiment, the present invention provides a fiberscope interfacing apparatus for an endoscope system insertable in a body cavity. The apparatus comprises an elongate communication medium having a first end and a second end for transmitting an optical signal of an image of the body cavity. The apparatus further comprises a lens attached to the first end of the communication medium for receiving the optical signal from the body cavity. The lens is in communication with the communication medium. The apparatus further comprises an interface collar attached to the second end of the communication medium and in communication therewith. The interface collar is configured to communicate with the

endoscope system and transfer the optical signal thereto for simultaneous fiber optic imaging and fluoroscopic imaging.

[0008] In another embodiment, the present invention comprises an endoscopic apparatus having simultaneous fluoroscopic and fiber optic imaging features for a body cavity. The apparatus comprises an endoscope including a control system for controlling the endoscope and an insertable tube. The insertable tube extends from the control system to a distal tip and is in communication with the control system. The apparatus further comprises a system tower in communication with the control system of the endoscope, and a video imaging apparatus in communication with the control system and the system tower for fluoroscopic imaging. The apparatus further comprises a fiberscope interfacing apparatus cooperable with the endoscope. The fiberscope interfacing apparatus is in communication with the video imaging apparatus for simultaneous fiber optic imaging and fluoroscopic imaging of the body cavity.

[0009] In yet another embodiment, the present invention comprises an endoscopic apparatus having simultaneous fluoroscopic and fiber optic imaging features for a body cavity. The endoscopic apparatus comprises an endoscope comprising a control system for controlling the endoscope, an insertable tube extending from the control system to a distal tip wherein the insertable tube is in communication with the control system, and a scope medium extending to a scope connector in communication with the control system. The endoscopic apparatus further comprises a system tower configured to receive the scope connector for communication with the control system and a fiberscope interfacing apparatus. The fiberscope interfacing apparatus is cooperable with the endoscope. The fiberscope

interfacing apparatus comprises an interface collar configured to connect to the scope connector for receiving an endoscope digital image signal. The interface collar is configured to convert a fiberscope optical signal to a fiberscope digital signal. The interface collar is further configured to convert the fiberscope digital image signal and the endoscope digital signal to a combined digital image signal. The endoscopic apparatus further comprises a video imaging apparatus that is configured to connect to the interface collar for receiving the combined digital image signal for simultaneous fluoroscopic and fiber optic imaging.

[0010] In another example, the present invention provides a method of simultaneous fluoroscopic and fiber optic imaging during an endoscopic procedure of a body cavity. The method comprises receiving a fiber optic image signal and converting the fiber optic image signal to a fiberscope digital signal. The method further comprises combining fiberscope digital signal with a fluoroscopic digital image signal to define a combined digital image signal. The method further comprises displaying the combined digital image signal for simultaneous imaging of the body cavity.

[0011] Further objects, features, and advantages of the present invention will become apparent from consideration of the following description and the appended claims when taken in connection with the accompanying drawings.

BRIEF DESCRIPTION OF THE DRAWINGS

[0012] Figure 1a is a perspective view of an endoscopic system having simultaneous fluoroscopic and fiber optic imaging features in accordance with one embodiment of the present invention;

[0013] Figure 1b is an elevated view of the endoscope system of Figure 1a;

[0014] Figure 1c is a perspective view of an elongate communication medium of a fiberscope interfacing apparatus in accordance with one embodiment of the present invention;

[0015] Figure 1d is a side view of the fiberscope interfacing apparatus in accordance with one embodiment of the present invention;

[0016] Figure 2 is a schematic view of the endoscope system implementing the fiberscope interfacing apparatus for simultaneous fiber optic imaging and fluoroscopic imaging;

[0017] Figure 3 is a side view of an interface collar for simultaneous fiber optic imaging and fluoroscopic imaging in accordance with one embodiment of the present invention;

[0018] Figure 4 is a flow chart of one method of simultaneous fiber optic and fluoroscopic imaging for an endoscope system in accordance with one example of the present invention; and

[0019] Figure 5 is a perspective view of a fluoroscope that may be used in combination with the fiberscope interfacing apparatus of the present invention.

DETAILED DESCRIPTION OF THE INVENTION

[0020] The present invention generally provides a fiberscope interfacing apparatus for an endoscope system having the capability of simultaneous fiber optic imaging and fluoroscopic imaging. This is accomplished by integrating an interface collar of the fiberscope interfacing apparatus with a video system of the endoscope system. The interface collar is configured to receive endoscope digital images and fiberscope images, combines the images for simultaneous viewing such as in a "picture-in-picture" signal, and transmits the images to the video system.

[0021] Figure 1a illustrates an endoscopic system 10 comprising an endoscope 11 having an insertion tube 12 in accordance with one embodiment of the present invention. In this embodiment, the insertion tube 12 is configured to be inserted into a body cavity for various endoscopic procedures including gastroscopy, sigmoidoscopy and colonoscopy, esophago gastro duodenoscopy (EGD), endoscopic retrograde cholangiopancreatography (ERCP), and bronchoscopy. As shown, the system 10 further comprises a fiberscope interfacing apparatus 110. In this embodiment, the insertion tube 12 has a plurality of channel ports through which endoscopic units may be disposed, e.g., the fiberscope interfacing apparatus 110 (see Figure 1b and 1d).

[0022] As shown in Figures 1a and 1b, the endoscope 11 includes a control system 14 that is in mechanical and fluid communication with the insertion tube 12. The control system 14 is configured to control the insertion tube 12 and endoscopic parts disposed therein. As shown, the control system 14 includes first and second control knobs 16, 18. The control knobs 16, 18 are configured to be in mechanical communication with the insertion tube 12. The control knobs 16, 18 allow the clinician to control and guide, by known means, the insertion tube 12 through vessels and cavities of a patient. The control system 14 further includes valve switches (e.g., suction valve 20, air/water valve 21, fluoroscopic/camera valve 22), each of which are in communication to one of the channel ports of the insertion tube 12. For example, the suction valve switch 20, when activated, allows a vacuum from a suction source through a suction channel port for suctioning unwanted plaque and debris from the patient. In one example, the distal end of the insertion tube 12 is inserted, rectally or orally, to a predetermined endoscopic location within a patient.

Insertion of the insertion tube 12 may be rectally or orally depending on the endoscopic procedure.

[0023] In this embodiment, the insertion tube 12 comprises an operating portion 25 connected to the control system 14 and extending to an insertion portion protecting member 26. The control system 14 is connected to the operating portion 25 and is configured to control the insertion tube 12. In this embodiment, the insertion tube 12 is composed of components that include a flexible tube 28, a flexure 29 connected to the flexible tube 28, and an endoscope tip 30 connect to the flexure 29. A scope medium or a universal cord 31, on one end, is connected and in communication with the control system 14. On the other end, the cord 31 has a connector 18 attached thereto. The connector 18 is in communication with a light guide tube and electrical contact, and is connected to an endoscopy system tower or a scope tower 32 including a light source apparatus and a video imaging apparatus (video tower) or an image processing apparatus 33. These external devices may include a monitor 34, an input keyboard 35, a suction pump apparatus 36, and an irrigation bottle 37, and other suitable apparatus are installed on a rack 39 equipped with rollers 38.

[0024] In one example, the distal end of the insertion tube 12 is inserted to a predetermined endoscopic location within a patient. Insertion of the insertion tube 12 may be rectally or orally depending on the endoscopic procedure. At the location, a physician may activate and control the endoscopic units as desired. The endoscope in combination with a fluoroscope and the fiberscope interfacing apparatus of the present invention allows for simultaneous fluoroscopic and fiber optic imaging. For example, this may be accomplished by injecting fluoroscopic dye

via a cannula (not shown) through the fluoroscopic valve 22, through the endoscope tip 30, and to a body vessel/cavity location in a patient. By a fluoroscope (Figure 5), fluoroscopy may be conducted to receive real-time images of internal structures through which an endoscope may otherwise not be able to pass, e.g., parts of the biliary tree of the patient.

[0025] Fluoroscopy is a study of moving body structures and is a procedure that provides motion video of an x-ray. Fluoroscopy enables physicians and other clinicians to view many body systems, including the skeletal, digestive, urinary, respiratory, and reproductive systems. Fluoroscopy may be performed to evaluate specific areas of the body, including the bones, muscles, and joints, as well as solid organs such as the heart, lung, or kidneys.

[0026] In this embodiment, the fluoroscope comprises an x-ray machine and a fluorescent screen (in communication with the x-ray machine) that may be used by physicians and other clinicians to view the internal organs of the body. During medical diagnosis, the patient is placed between the x-ray machine and the fluorescent screen. A continuous x-ray beam is passed through a body part being examined and is transmitted by a scanner to the video imaging apparatus 33 so that the body part and its motion can be seen in detail. As radiation passes through the body, varying degrees of light and shadow on the screen is produced.

[0027] Fluoroscopy may be used in various types of examinations and procedures, such as barium x-rays, cardiac catheterization, arthrography (visualization of a joint or joints), lumbar puncture, placement of intravenous catheters, intravenous pyelogram, hysterosalpingogram, and biopsies. For example, in barium x-rays, fluoroscopy allows the physician to see the movement of the

intestines as the barium moves through them. In cardiac catheterization, fluoroscopy is added to enable the physician to see the flow of blood through the coronary arteries in order to evaluate the presence of arterial blockages. For intravenous catheter insertion, fluoroscopy assists the physician in guiding the catheter into a specific location inside the body.

[0028] During the same procedure and at the same time, the fiberscope interfacing apparatus (discussed in greater detail below) may be used with the endoscope to receive real-time digital images of internal structures through which the endoscope is introduced, e.g., the duodenum or the small intestine of the patient. The signals or images from each of the fluoroscope and fiberscope interfacing apparatus may then be combined and displayed through a video monitor as cascading views, picture-in-picture, alternating views, or any other suitable views.

[0029] Figures 1b-2 illustrate a fiberscope interfacing apparatus 110 for the endoscope system 10 in accordance with one embodiment of the present invention. As shown, the fiberscope interfacing apparatus 110 comprises an elongate communication tube or medium 112 for transmitting a light signal or an optical signal of an image from the body cavity. In this embodiment, the elongate communication medium 112 has a first (or distal) end 114 and a second (or proximal) end 115 through which an optical signal may be transmitted by the endoscope to the body cavity and then to an imaging system as described in greater detail below.

[0030] In this embodiment, the elongate communication tube 112 is an optical fiber medium that includes at least one fiber core 122 having a predetermined refractive index. Preferably, an optical fiber is a cylindrical dielectric waveguide that transmits light along its longitudinal axis by the process of total internal reflection. In

this embodiment, the medium 112 further comprises a cladding layer 124 disposed about each of the fiber cores 122 for transmission of optical signals from the first end 114 to the second end 115 of the communication medium 120. Preferably, each cladding layer 124 has a refractive index that is less than the predetermined refractive index of each of the fiber cores. That is, for total internal reflection to confine the optical signal in the core, the refractive index of the core 122 is preferably greater than that of the cladding layer 124.

[0031] Preferably, each cladding layer 124 is coated with a resin buffer layer 126. The resin buffer layer 126 may be made on any suitable non-conductive material such a polymeric material. In this embodiment, the medium 112 further comprises a polymeric jacket layer 130 disposed about one or all of the resin buffer layers 126 for added strength to the fiber core 122.

[0032] In this embodiment, the fiberscope interfacing apparatus 110 further comprises a lens 132 (Figures 1d and 3) attached to the first (or distal) end 114 of the communication medium 112 by any suitable means. Preferably, the lens 132 is configured to receive optical signals transmitted by the endoscope through the body cavity and is in communication with the communication tube 112 to allow transmission of optical signals therethrough. The lens 132 may be any suitable type of lens, e.g., a wide-angle lens, for receiving optical signals therethrough. In use, light transmitted by through the endoscope to the body cavity is preferably provided by the light source apparatus of the system tower 32 via the scope medium 31 and insertion tube 12. Other ways of transmitting light to the body cavity may be implemented without falling beyond the scope or spirit of the present invention.

[0033] As shown, the fiberscope interfacing apparatus 110 further comprises an interface collar 134 attached to and in communication with the second (or proximal) end 115 of the communication medium 112. Preferably, the interface collar 134 is configured to communicate with the external devices, e.g., the system tower 32 and the video imaging apparatus 33 of the endoscope system 10 to transmit light or optical signals thereto for simultaneous fiber optic and fluoroscopic imaging as the system tower 32 of the endoscopic system 10 is in communication with the control system 14.

[0034] As mentioned above, the scope medium 31 extends to a scope connector 18. The interface collar 134 attaches to the connector 18, generally receives the endoscope digital signal, and converts the fiberscope image signal to a fiberscope digital signal. The interface collar 134 combines the endoscope digital signal and the fluoroscopic image signal into a combined signal for simultaneous imaging, e.g., a cascading view or a picture-in-picture view.

[0035] The system tower 32 is configured to receive the scope connector 18 for communication between the endoscope 11, fiberscope interfacing apparatus 110, and the system tower 32. In this embodiment, this is accomplished by attaching the interface collar 134 to the scope connector 18 as shown in Figures 2 and 3. Preferably, the scope connector 18 has an end 141 configured to connect with the system tower 32 and has a side portion 142 configured to receive the interface collar 134. As shown in Figures 2 and 3, the interface collar 134 comprises a first face 144 and a second face 145. In this embodiment, the first face 144 is a pin-out face that mates with the side portion 142 of the scope connector 18. The side portion 142 of the scope connector 18 allows for endoscope digital image signals to be transmitted

to the interface collar 134. As mentioned in greater detail below, the interface collar is configured to transmit the signals to the video imaging apparatus. The transmission of digital image signals mentioned herein may be accomplished by any suitable means.

[0036] Each of U.S. patents 7,120,282; 6,985,555; 6,952,464; 6,912,266; 6,912,266; 6,975,338; 5,841,491; 5,124,789 and 6,895,077 is incorporated herein by reference in its entirety.

[0037] As shown, the video imaging apparatus 33 includes a video coupling 150 extending therefrom. In this embodiment, the video coupling 150 has a receiving pin-out face 152 that mates with the second face 145 of the interface collar 134. The interface collar 134 receives the video coupling 150 to transmit signals to the video imaging apparatus 33 for simultaneous fluoroscopic and fiber optic imaging.

[0038] In one example, images from the fiberscope are converted to fiberscope digital image signals by the interface collar. Preferably, this is accomplished by projecting the images obtained from the fiber optic core of the fiberscope onto a CCD (charged couple display) contained within the interface collar. The interface collar receives the digital endoscope image signal by interfacing the first face with the side portion of the scope connector. In this example, the fiberscope images are integrated with the endoscope.

[0039] After fluoroscopic dye is injected into a body cavity, the digital signals from the fiberscope and fluoroscope would next be combined within the interface collar so that the combined digital image signal now represents an image appearing as a "picture-in-picture" digital image. This digital signal is then outputted to the

video coupling via the same pin-outs into a video display of an system tower, so that the images from both the fiberscope and fluoroscope are displayed simultaneously on the video monitor. In one embodiment, the fluoroscopic mechanism of the endoscopic system exists as a device separate from the endoscope and is only used to inject contrast medium into the body cavity so that the anatomy may be seen more clearly.

[0040] Figure 4 depicts an example of one method 210 of simultaneous fluoroscopic and fiber optic imaging during an endoscopic procedure. As shown, the method comprises receiving in box 212 a fluoroscopic digital image signal. In one example, this is accomplished by use of a fluoroscope 310 (see Figure 5) in combination with the endoscope mentioned above. As shown, the fluoroscope 310 comprises an x-ray machine 312 having an x-ray scanner, and a fluorescent screen bed (or x-ray table) 314 that is in communication with the x-ray machine 312. The video imaging apparatus 33 (mentioned above) is in communication with the x-ray machine 312 to allow for viewing of the internal organs of the body.

[0041] In this example, an intravenous (IV) line may be inserted in the patient via hand or arm while the patient is positioned on the x-ray table. Moreover, the endoscope is introduced into the patient to an area adjacent the target location, e.g., the duodenum for fluoroscopy of within the biliary tree. Fluoroscopic dye or contrast substance may be injected into the endoscope line in order to better visualize the structure being studied. That is, fluoroscopic dye may be injected into a body cavity location via the fluoroscopic value 22 of the endoscope by a fluoroscopic cannula or catheter. The body cavity location may be a location that the endoscope may otherwise not be able to access, e.g., the biliary tree. As mentioned above, once the

dye is injected into the body cavity, the fluoroscopic digital image signal is generated by the fluoroscope and may be converted to real-time video as discussed herein. In one example, the x-ray scanner may be used to receive x-ray signals, convert to digital video signals, and generate fluoroscopic images of the body structure being examined or treated.

[0042] In this example, a fiber optic image signal is then received and converted in box 214 to a fiberscope digital signal by the interface collar as discussed above. Preferably, the fluoroscopic and the fiberscope digital signals are then combined in box 216 by the interface collar by any suitable means mentioned above to define a combined digital image signal. The combined digital image signal allows for real-time video display of the body cavity remote from the endoscope (e.g., an area of the biliary tree inaccessible by the endoscope) and real-time video display of the area adjacent the endoscope (e.g., the duodenum).

[0043] The method further comprises displaying in box 218 the combined digital image signal for simultaneous imaging (remote and proximal views simultaneously). This is accomplished by receiving the signal with the video coupling and transmitting the signal to the video imaging apparatus having a video monitor that displays the combined digital image in a cascading view or picture-in-picture view.

[0044] While the present invention has been described in terms of preferred embodiments, it will be understood, of course, that the invention is not limited thereto since modifications may be made to those skilled in the art; particularly in light of the foregoing teachings.

CLAIMS

1. A fiberscope interfacing apparatus for an endoscope system insertable in a body cavity, the apparatus comprising:

an elongate communication medium having a first end and a second end for transmitting an optical signal of an image of the body cavity;

a lens attached to the first end of the communication medium for receiving the optical signal from the body cavity, the lens being in communication with the communication medium; and

an interface collar attached to the second end of the communication medium and in communication therewith, the interface collar being configured to communicate with the endoscope system and transfer the optical signal thereto for simultaneous fiber optic imaging and fluoroscopic imaging.

2. The apparatus of claim 1 wherein the elongate communication medium comprises an optical fiber medium including a fiber core having a predetermined refractive index, a cladding layer disposed about the fiber core and having a lower refractive index, a resin buffer layer disposed about the cladding layer, and a jacket layer disposed about the buffer layer for transmission of the optical signal from the first end to the second end of the communication medium.

3. The apparatus of claim 2 wherein the lower refractive index is less than the predetermined refraction index.

4. The apparatus of claim 1 wherein the lens is a wide-angle lens.

5. An endoscopic apparatus having simultaneous fluoroscopic and fiber optic imaging features for a body cavity, the apparatus comprising:

an endoscope comprising;

a control system for controlling the endoscope; and

an insertable tube extending from the control system to a distal tip, the insertable tube being in communication with the control system;

a system tower in communication with the control system of the endoscope;

a video imaging apparatus in communication with the control system and the system tower for fluoroscopic imaging; and

a fiberscope interfacing apparatus cooperable with the endoscope and in communication with the video imaging apparatus for simultaneous fiber optic imaging and fluoroscopic imaging of the body cavity.

6. An endoscopic apparatus having simultaneous fluoroscopic and fiber optic imaging features for a body cavity, the apparatus comprising:

an endoscope comprising:

a control system for controlling the endoscope;

an insertable tube extending from the control system to a distal tip, the insertable tube being in communication with the control system; and

a scope medium extending to a scope connector in communication with the control system;

a system tower configured to receive the scope connector for communication with the control system;

a fiberscope interfacing apparatus cooperable with the endoscope, the fiberscope interfacing apparatus comprising an interface collar configured to connect to the scope connector for receiving an endoscope digital image signal, the interface collar being configured to convert a fiberscope optical signal to a fiberscope digital signal, the interface collar further being configured to convert the fiberscope digital image signal and the endoscope digital signal to a combined digital image signal; and

a video imaging apparatus configured to connect to the interface collar for receiving the combined digital image signal for simultaneous fluoroscopic and fiber optic imaging.

7. The apparatus of claim 6 wherein the elongate communication medium comprises an optical fiber medium comprising a fiber core having a predetermined refractive index, a cladding layer disposed about the fiber core and having a lower

refractive index, a resin buffer layer disposed about the cladding layer, and a jacket layer disposed about the buffer layer for transmission of the optical signal from the first end to the second end of the communication medium.

8. The apparatus of claim 7 wherein the lower refractive index is less than the predetermined refraction index.

9. The apparatus of claim 6 wherein the lens is a wide-angle lens.

10. The apparatus of claim 6 wherein the fiber scope interfacing apparatus comprises:

an elongate communication medium having a first end and a second end for transmitting an optical signal of an image of the body cavity;

a lens attached to the first end of the communication medium for receiving the optical signal from the body cavity, the lens being in communication with the communication medium; and

an interface collar attached to the second end of the communication medium and in communication therewith, the interface collar being configured to communicate with the endoscope system and transfer the optical signal thereto for imaging.

11. The apparatus of claim 10 wherein the fiber scope interfacing apparatus comprises a light source for emitting light through the elongate communication medium for reflecting optical signals therethrough.

12. The apparatus of claim 6 wherein the interface collar is configured to transfer optical signals from the first end of the elongate communication medium to the video imaging apparatus.

13. The apparatus of claim 12 wherein the video imaging apparatus is configured to receive the optical signal and process an image of the body cavity.

14. The apparatus of claim 6 wherein the distal coupling comprises a first connection port and a second connection port, the first connection port attachable to the system tower and the second connection port configured to receive the interface collar and to connect with the video imaging apparatus for video imaging of the optical signal.

15. A method of simultaneous fluoroscopic and fiber optic imaging during an endoscopic procedure of a body cavity, the method comprising:

receiving a fiber optic image signal;

converting the fiber optic image signal to a fiberscope digital signal;

combining fiberscope digital signal with a fluoroscopic digital image signal to define a combined digital image signal; and

displaying the combined digital image signal for simultaneous imaging of the body cavity.

16. The method of claim 15 further comprising:

receiving the fluoroscopic digital image signal.

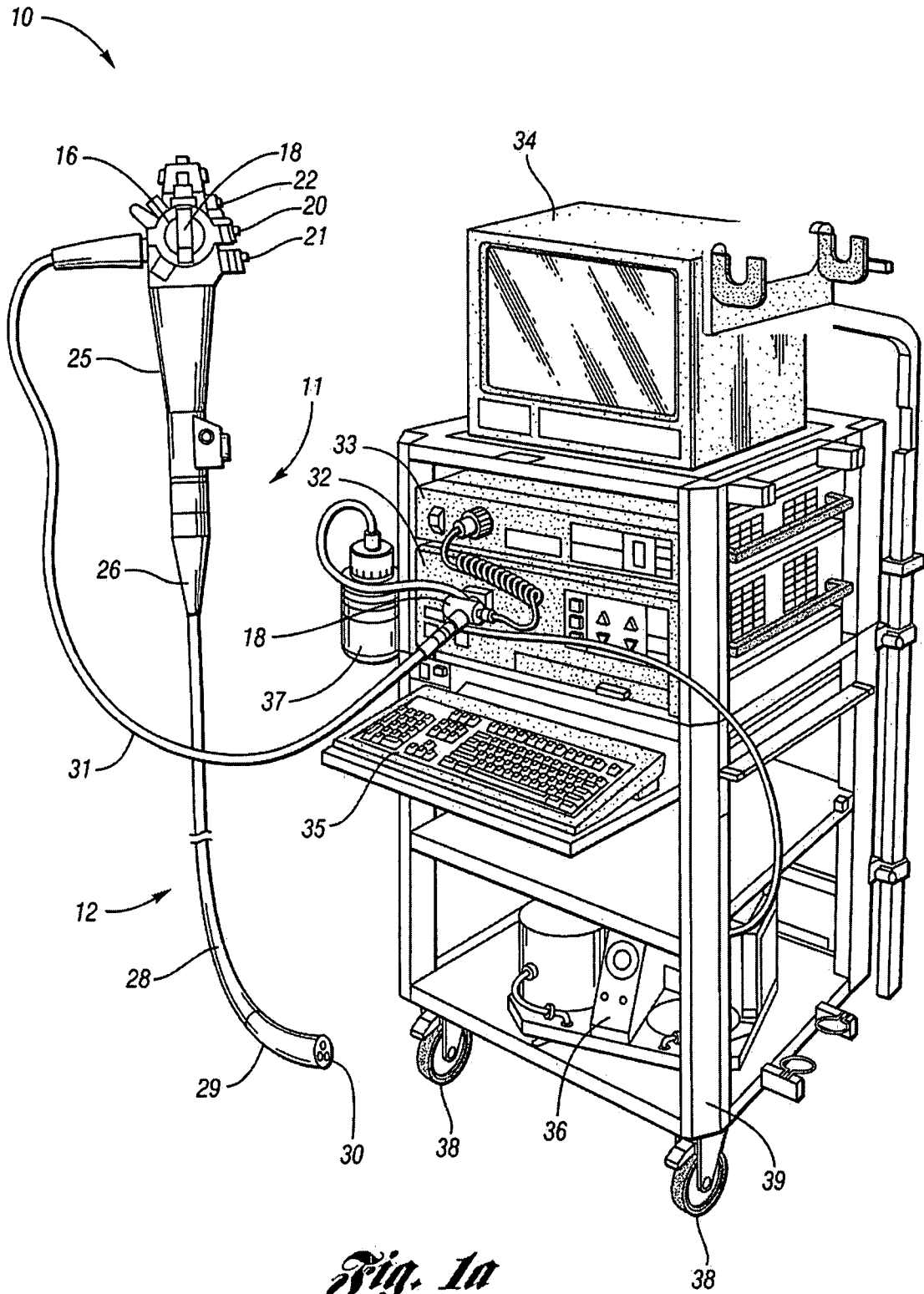

Fig. 1a

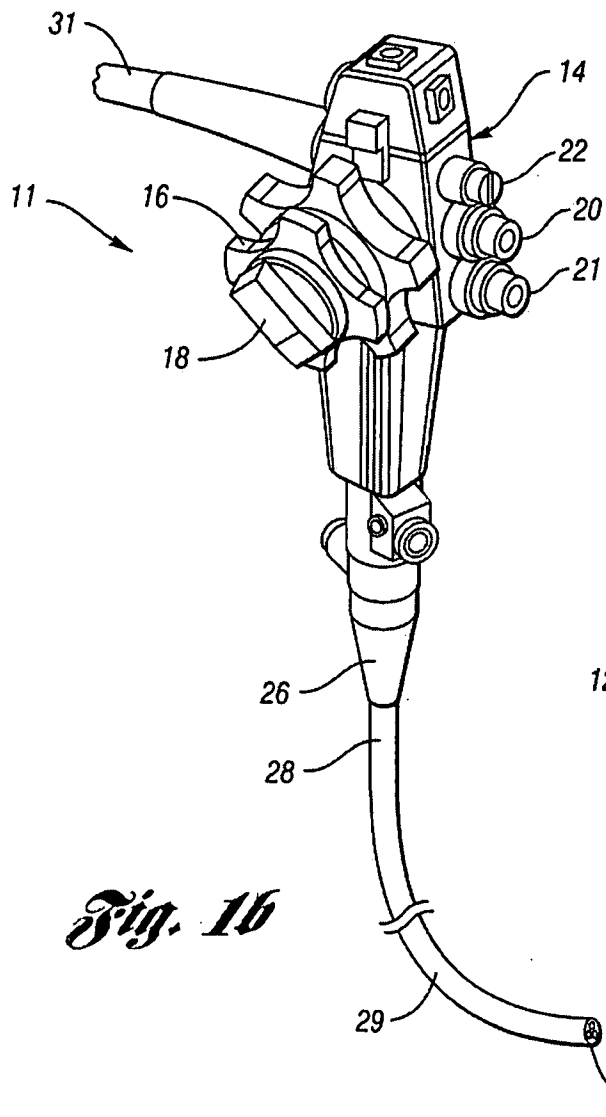

Fig. 1a

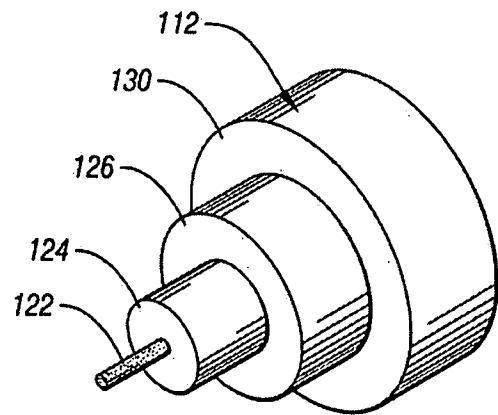

Fig. 1c

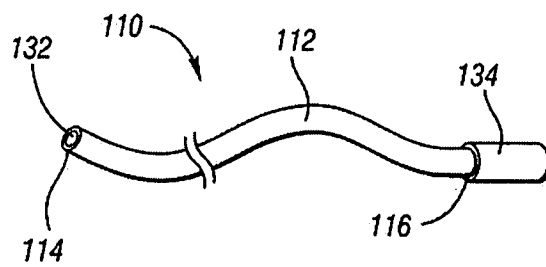

Fig. 1b

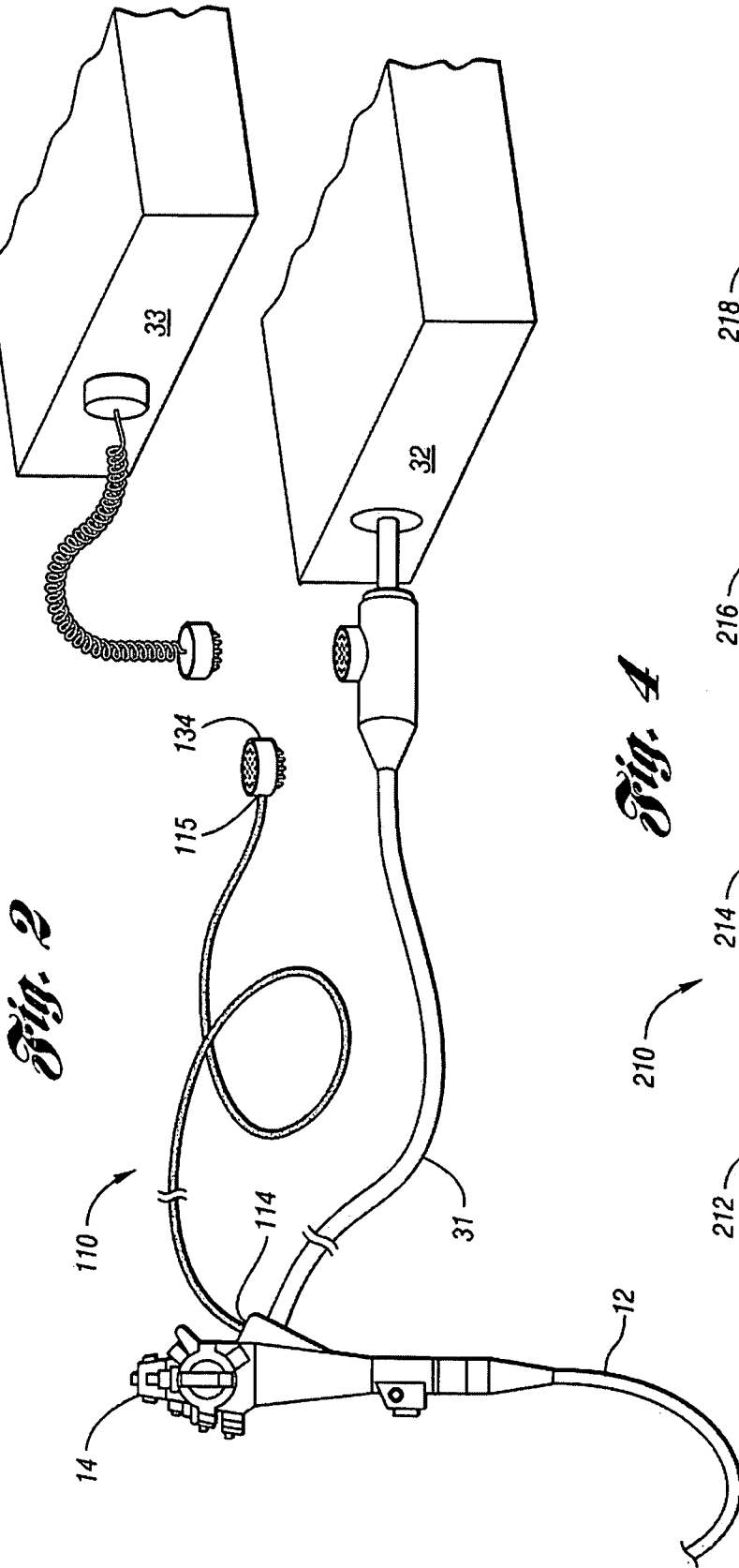
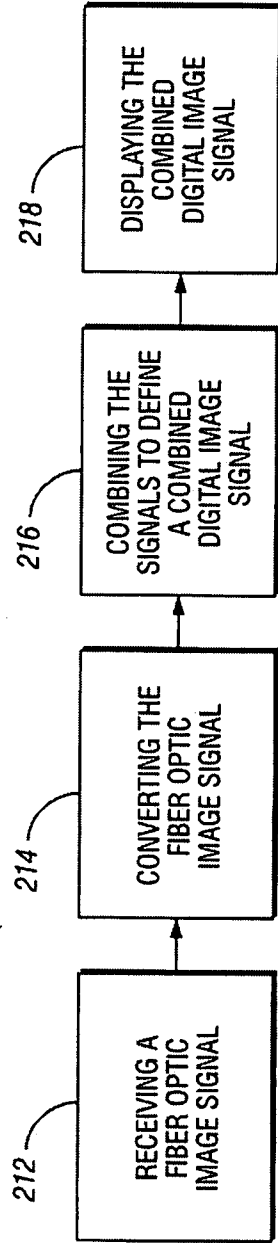

Fig. 4



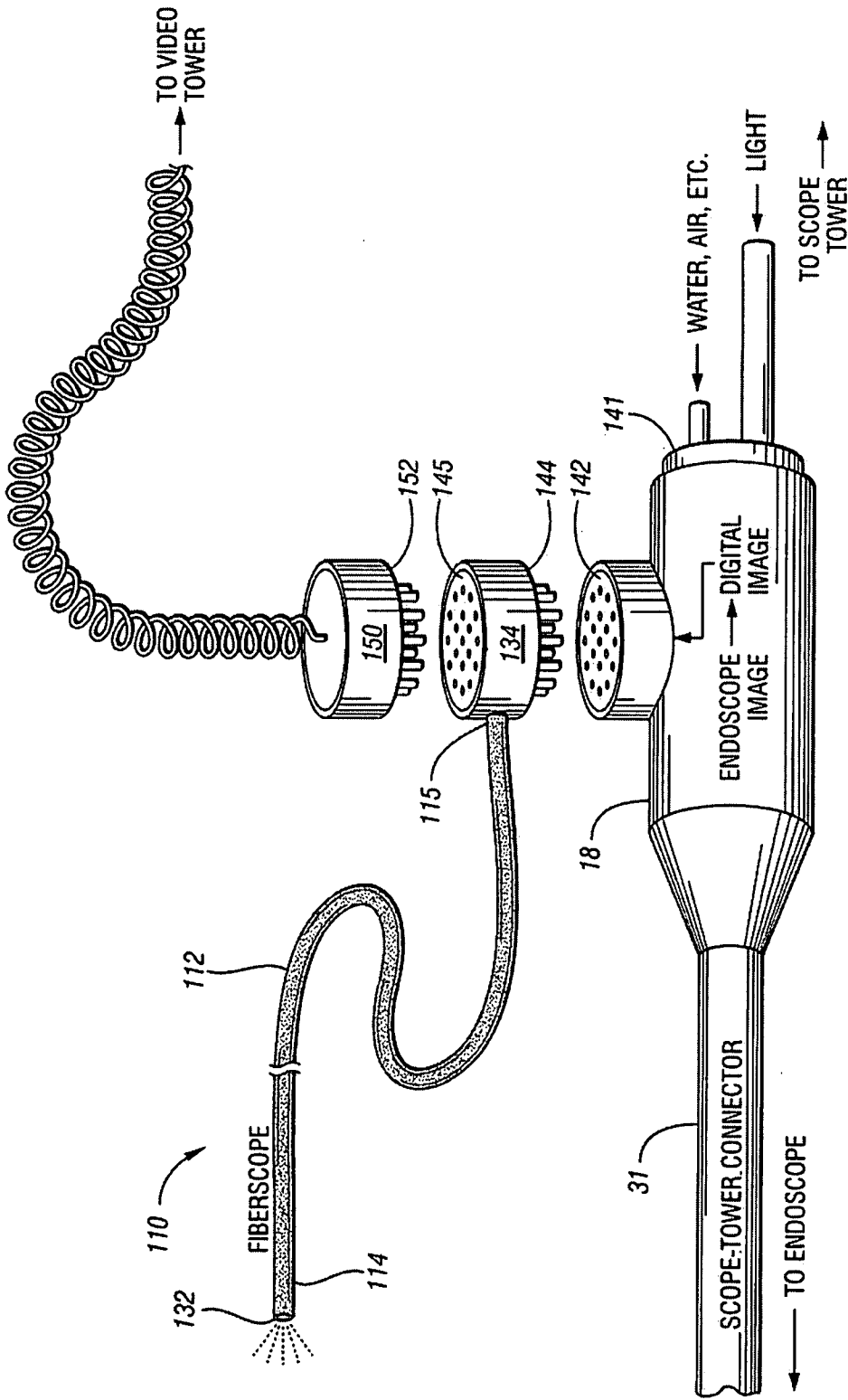

Fig. 3

5/5

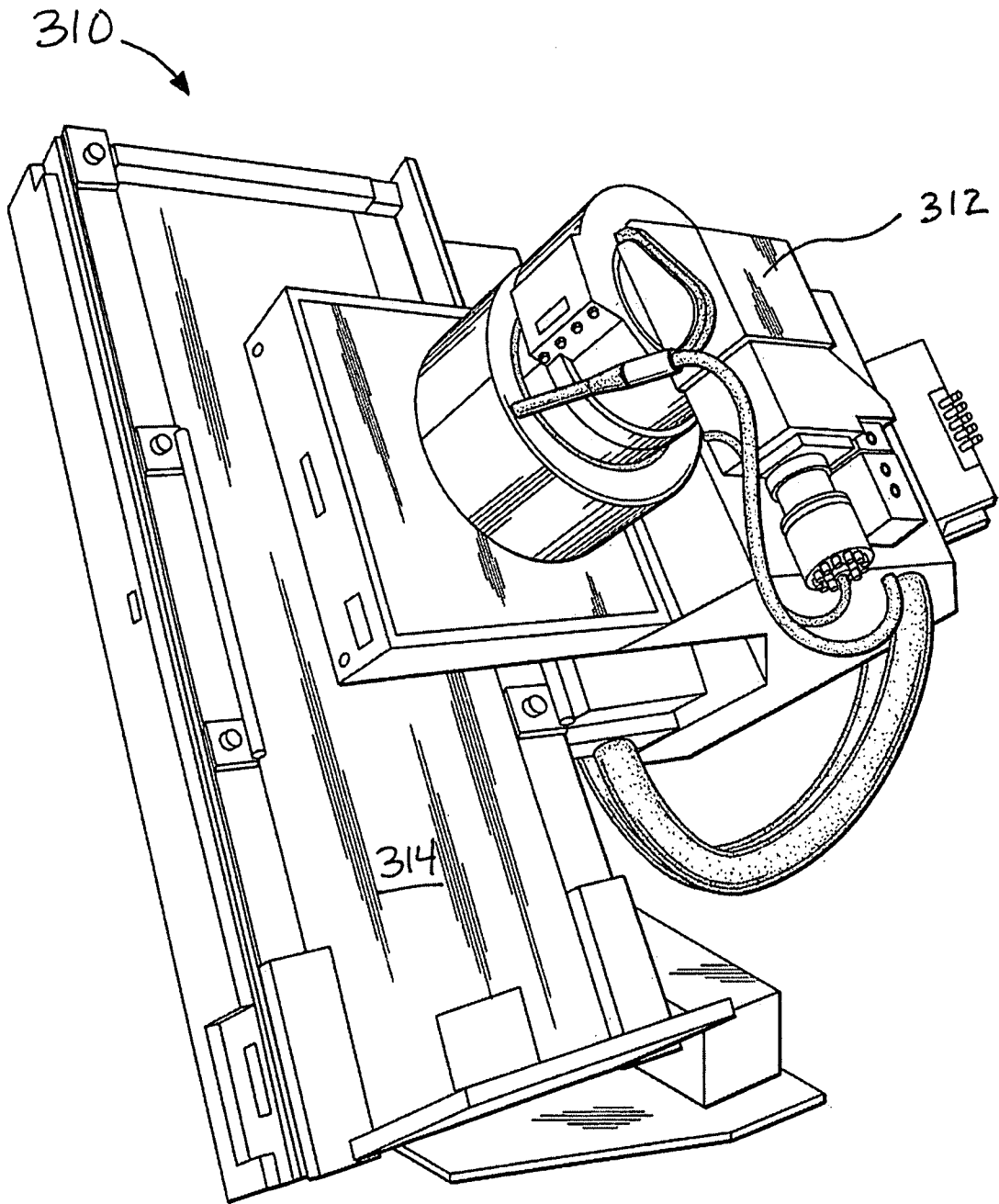

Fig. 5