

E. LANGILLE.

TRUCK.

APPLICATION FILED DEC. 7, 1910.

996,723.

Patented July 4, 1911.

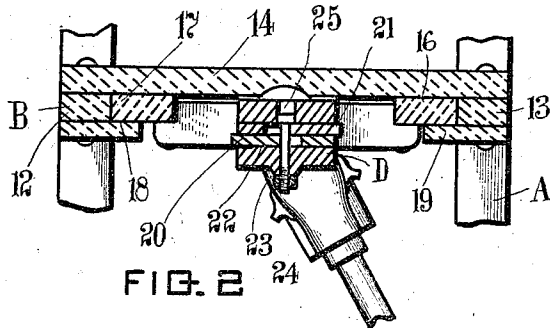

FIG. 2

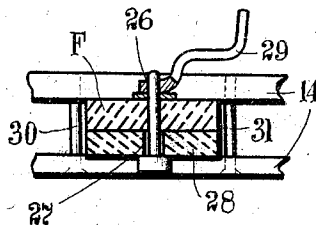

FIG. 3

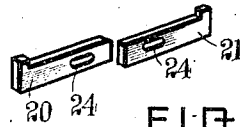

FIG. 4.

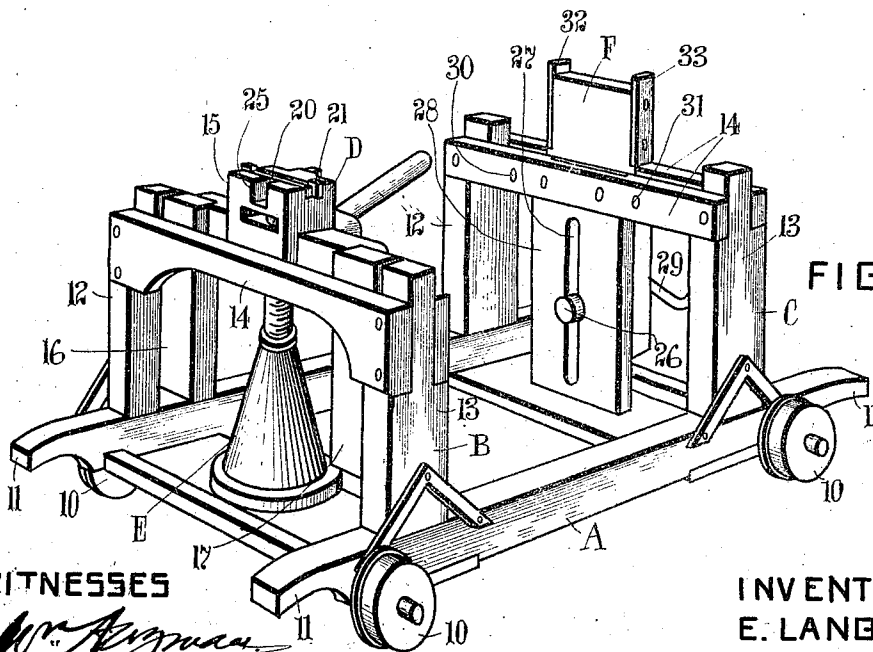

FIG. 1.

WITNESSES

Wm. A. ...
M. Gilbertson

INVENTOR
E. LANGILLE

BY

...
ATTY.

UNITED STATES PATENT OFFICE.

ELIJAH LANGILLE, OF STELLARTON, NOVA SCOTIA, CANADA.

TRUCK.

996,723.

Specification of Letters Patent.

Patented July 4, 1911.

Application filed December 7, 1910. Serial No. 596,141.

To all whom it may concern:

Be it known that I, ELIJAH LANGILLE, of Stellarton, in the Province of Nova Scotia, Dominion of Canada, have invented certain new and useful Improvements in Trucks, of which the following is a specification.

This invention relates to improvements in machines for removing and applying couplers or draw bars from and to freight, passenger and other railroad cars and tenders, and the objects of the invention are to provide a simple and effective device of this character which will enable couplers or draw bars to be applied or removed very rapidly with a minimum amount of labor and with the attention of a minimum number of hands.

Another object is to provide an instrumentality of the class specified which from an operative standpoint will, in usage, possess a high degree of efficiency and effectiveness and which structurally considered, will be of the greatest possible simplicity, being composed of but a few parts, all adapted for being made at a minimum cost and individually so formed as to be capable of being readily assembled in compact arrangement for accomplishing the purposes intended.

Other objects and advantages will be in part obvious and in part pointed out hereinafter.

With these and other ends in view this invention accordingly consists in the features of construction, combination of parts, and arrangement of elements hereinafter more explicitly set forth as an exemplification of the underlying principles of the invention.

In order that this invention may be more fully understood and be comprehensible to others skilled in the art, drawings illustrating a convenient means of carrying out the same are pointed out as part of this specification, and while the underlying principles of the invention may be otherwise applied by modifications falling within the scope of the claims, the hereinafter disclosed embodiment is that which will ordinarily be preferable to employ in practice and is regarded as representing substantial improvements over the many obvious or implied variations of the same.

In such drawings it is to be noted that like numerals refer to corresponding parts throughout all the figures in the drawings, in which:

Figure 1 is a perspective view of the ap-

paratus. Fig. 2 is a horizontal section through the forward frame. Fig. 3 is a horizontal section through the clamping means on the rearward frame. Fig. 4 is a perspective view of the clamping dogs on the forward frame.

Referring to the drawings, A represents a suitable truck adapted to run on a railway track, or on the floor of a shop between the tracks, and provided with suitable wheels 10 for this purpose, and with handles 11 by means of which the truck may be lifted on and off the track.

This truck is arranged to carry slide frames B and C at opposite ends, each of which consists of side posts 12 and 13 on opposite sides of the truck and cross bars 14 at the top.

D represents a slide mounted on the front frame, which includes an upper member 15, conveniently in the form of a casting, and side members 16 and 17 sliding in guide-ways 18 and 19 provided on the frame.

Means are provided to vertically adjust the slides; the means illustrated to adjust the front slide comprising a ratchet jack E of usual construction. The upper member 15 is provided on its upper surface with means to engage the coupler or draw bar, these means in the embodiment illustrated comprising laterally sliding and overlapping dogs 20 and 21 held in a slot 22 formed in the upper face of the section 15, said dogs being held in adjusted position by means of a bolt 23 extending through slots 24 in the dogs and through the section 15, the head of the bolt being held from rotation in a slot 25 in one side of the upper section 15.

Mounted between the cross bars 14, is a rear slide F, adapted to connect the side members of the frame and provided with a clamping bolt 26 extending through a vertically extending slot 27 formed in a guide member 28, the bolt being adapted to be clamped by means of a handle 29 on one side thereof which has screw-threaded engagement with the bolt.

The upper part of the slide is permitted slight lateral play between stop pins 30 and 31, and the top of the slide is provided with means to prevent lateral sliding of the draw-bar or coupler thereon, these means comprising stop plates 32 and 33 projecting above the upper surface. If desired both jacks could be operated by ratchet jacks.

In using the appliance, the draw bar or

coupler is placed on the slides and then may be moved by the truck into its proper position, and the height of opposite ends may be independently adjusted by adjustment of the slides. In this way, the coupler or draw-bar may be rapidly fitted into position.

As many changes could be made in the above construction and many apparently widely different embodiments of the invention within the scope of the claims constructed without departing from the spirit or scope thereof, it is intended that all matter contained in the accompanying specifications and drawings shall be interpreted as illustrative and not in a limiting sense.

What I claim as my invention is:

1. In an apparatus of the character described, a truck having spaced frames thereon, vertically adjustable slides in the frames, one of said slides having a transverse slot formed at the top thereof, overlapping and transversely sliding dogs in said slot, and means for clamping the dogs in adjusted position.

2. In an apparatus of the character described, a truck having a frame thereon, a vertically adjustable slide in the frame, a transverse slot formed at the top thereof, overlapping and transversely slidable dogs in said slot, and means for clamping the dogs in adjusted position, said means comprising a clamping bolt extending through slots in the dogs.

3. The combination with a truck of spaced frames thereon, slides vertically movable in the frames, one of said slides being supported with freedom of slight lateral play, stoppins limiting the lateral play, means for clamping the slide having lateral play in raised position, and a jack for raising the opposite slide.

In witness whereof I have hereunto set my hand in the presence of two witnesses.

ELIJAH LANGILLE.

Witnesses:

R. A. MACDONALD,
W. D. EINERY.