



(11) **EP 2 199 244 B1**

(12) **EUROPEAN PATENT SPECIFICATION**

(45) Date of publication and mention
of the grant of the patent:
03.08.2011 Bulletin 2011/31

(51) Int Cl.:
B66B 9/04 (2006.01)

(21) Application number: **09179422.2**

(22) Date of filing: **16.12.2009**

(54) **Hydraulic lift**

Hydraulischer Aufzug

Ascenseur hydraulique

(84) Designated Contracting States:
**AT BE BG CH CY CZ DE DK EE ES FI FR GB GR
HR HU IE IS IT LI LT LU LV MC MK MT NL NO PL
PT RO SE SI SK SM TR**

(30) Priority: **19.12.2008 IT GE20080106**

(43) Date of publication of application:
23.06.2010 Bulletin 2010/25

(73) Proprietor: **Filippo Rolla S.r.l.**
16125 Genova (IT)

(72) Inventor: **Rolla, Edoardo**
I-16136, GENOVA (IT)

(74) Representative: **Porsia, Attilio et al**
Via Caffaro 3/2
16124 Genova (IT)

(56) References cited:
EP-A2- 0 254 840 WO-A1-00/71456
DE-A1- 3 002 577 JP-A- 2001 063 939

EP 2 199 244 B1

Note: Within nine months of the publication of the mention of the grant of the European patent in the European Patent Bulletin, any person may give notice to the European Patent Office of opposition to that patent, in accordance with the Implementing Regulations. Notice of opposition shall not be deemed to have been filed until the opposition fee has been paid. (Art. 99(1) European Patent Convention).

Description

[0001] The present invention relates to hydraulic lifts. As is known, in order to facilitate installation inside narrow shafts, hydraulically operated lifts have been developed where the cabin is raised and lowered by means of the reciprocating displacement of a piston sliding inside a single-acting cylinder, the end of which is mounted on the floor of the pit inside the lift travel shaft. A side elevation and partially sectioned view of an example of a known hydraulic lift is shown schematically in Fig. 1 of the accompanying drawings. With reference to this figure, 8 denotes a tubular cylinder which extends from the bottom floor 4 of the lift pit to about halfway along the overall height of the travel which is to be performed by the lift cabin 1. A piston 7, which extends externally through a fluid-tight opening 9 at the top end of the cylinder 8, is mounted slidably inside the cylinder 8. A pulley 3, which is rotatably supported by the shaft 5, is keyed onto the free end of the piston 7. 2 denotes two or more cables which are secured at one end to an anchoring point 104 on the base of the bottom floor 4 of the lift pit and pass around the pulley 5 downwards as far as the anchoring point on the structure of a cabin 1 which is guided, in a manner known per se, so as to slide between special lateral guides (not shown).

[0002] 10 denotes a tubular union which is connected to a hydraulic circuit associated with a pump (not shown). By operating the pump it is possible to allow alternately the entry of a hydraulic fluid into the cylinder 8 via the union 10, thereby causing raising of the piston 7 carrying the pulley 5 which, via the cable 2, will cause raising of the cabin 1 along the lift travel shaft. Allowing the hydraulic fluid to flow out freely through the union 10 results in the downwards movement of the cabin by means of gravity.

[0003] The document DE 3002577 A1 describes an hydraulic lift in which, via a loose pulley and a rope, a cylinder drives a car with a total load ($Q + F$), in which Q is the movable load and F is the weight of the car, and in which the cylinder carries a counterweight to the value of $2(Q/2 + F)$. Furthermore, the cylinder is guided along piston rod which is under prestress Q , is anchored in a foundation and at the same time has a bore for supplying the hydraulic fluid. Due to the movement of the cylinder along the piston rod under prestress, a smaller design of the piston rod than in the conventional arrangement with fixed cylinder and movable piston rod is obtained.

[0004] The document JP 2001063939 A describes a movable cylinder and hydraulic elevator using it in which the lower end of a hollow upper piston rod is fixed to the upper face of a piston, and an upper side inner port is provided near there in communication with the hollow portion and an upper side outer port is provided near the upper end as a fixed point of the upper piston rod in communication with the hollow portion. The upper end of a hollow lower piston rod is fixed to the lower face of the piston, and a lower side inner port is provided near there

in communication with the hollow portion and a lower side outer port is provided near the lower end as a fixed point of the lower piston rod in communication with the hollow portion. An upper cylinder chamber on the upper side of the piston and a lower cylinder chamber on the lower side of the piston are provided in a cylinder tube slidable vertically with the inner periphery being inscribed on the outer periphery of the piston.

[0005] The document WO 00/71456 A1 describes a hydraulic elevator installation, comprising a counterweight, in which a cylinder can be displaced along a piston rod. Said piston rod can be connected in a fixed manner to sections of a building. The cylinder has two pressure chambers, between which hydraulic oil can be circulated, using a pump. This process displaces the cylinder along the piston rod. The movement of the cylinder is transmitted to a cabin by means of a cable which is guided over deflection pulleys. In this assembly, the cylinder forms part of the counterweight in relation to the cabin. According to the invention, the pump and a motor which drives the same are fixed to the cylinder in such a way that these also function as part of the counterweight.

[0006] The document EP 0254 840 A2 describes a lifting device having a hydraulic linear motor, which is made up of a double-acting hydraulic cylinder and two stationary anchored piston rods, connected to the piston. A cage is effectively connected to the hydraulic cylinder via a roller of a cable line, fastened at the upper end of the hydraulic cylinder. The hydraulic drive is connected via a control unit through its supply lines to connection points of the hollow-drilled piston rods, and consequently to the hydraulic cylinder. In order to keep the drive power of the hydraulic drive small, the overall load is compensated, at least partly, by a counterweight, which is fastened to the hydraulic cylinder.

[0007] The known hydraulic lifts of the type described above schematically with reference to Figure 1 of the drawings and in the documents cited above have various drawbacks, in particular from the point of view of the power which is dissipated during their operation. These hydraulic lifts, in fact, result in a considerable amount of wasted energy since they always have to move the weight of the cabin with or without passengers.

[0008] The object of the present invention is therefore to provide a hydraulic lift which is able to overcome the drawbacks of the known hydraulic lifts, which allows optimization of the amount of energy which is used in order to raise and lower the cabin, resulting in a considerable saving in energy which can be calculated as being equivalent to about two thirds of that of the hoisting systems of conventional hydraulic lifts, and in which, advantageously, it is possible to adjust the working stroke of the cylinder so as to ensure mechanical stoppage of the cylinder at the end surfaces, without having to provide a cylinder/piston assembly especially for each use, but by constructing it in modular fixed sizes

[0009] This object is achieved by the present invention with a hydraulic lift according to Claim 1.

[0010] Further characteristic features and advantages of the present invention will emerge more clearly from the following description, provided by way of a non-limiting example with reference to the other accompanying drawings in which:

- Fig. 2 is a schematic side elevation view of a known hydraulic lift with counterweight
- Fig. 3 shows a cross-sectional view along the line III-III of Fig. 2 of the known hydraulic lift with counterweight;
- Fig. 4 shows a schematic side elevation view of the hydraulic lift according to the present invention and
- Fig. 5 shows a cross-sectional view along the line V-V of Fig. 4 of the hydraulic lift.

[0011] With reference firstly to Figure 3 in the drawings, the known hydraulic lift comprises a tubular riser 17 consisting of two fixed tubular stems which are fixed at their ends between the bottom part or floor 4 of the travel shaft of the lift cabin and the top part or ceiling 12 of this shaft. The stems of the riser 17 are connected at their ends to unions 18 and 19 for supplying and/or discharging, respectively, a hydraulic fluid, which are associated with a hydraulic circuit comprising a motor-driven pump (not shown). 121 denotes a fixed cylindrical piston which is positioned at the central end of the stems of the riser 17 and is concentric with said stems of the tubular riser. Said piston 121 also comprises a fixed diaphragm 221 which divides the internal compartment of said tubular riser 17 into two chambers 26 and 126 which are not interconnected. 16 denotes a movable cylinder which is positioned coaxially around these stems of the fixed riser 17 so as to create a cylindrical cavity 20 and 120 which is formed between these stems of the fixed riser 17 and this movable cylinder 16 and inside which said fixed cylindrical piston 121 is sealingly positioned for example by means of a double set of O-rings 22. The chambers 26 and 126 communicate, upstream and downstream of the piston 121, respectively, via radial apertures 24 and 23, with the cylindrical cavities 120 and 20 of the cylinder 16. Seals 25 ensure fluid-tightness between the ends of the cylinder 16 and the riser 17. The counterweight 15 is mounted on the cylinder 16, and the idle pulleys 13 are keyed onto the cylinder/counterweight assembly by means of the spindles 14. The movable cylinder 16 has a length equal to about half the height of the fixed riser 17 for the purposes which will be described below.

[0012] With reference now to Fig. 2 of the accompanying drawings, 1 denotes the cabin of the lift. The ends of the cables 2 (only one of which is visible in the figures) are fixed to the structure of the cabin 1. Each of these cables 2 is driven, upstream of the cabin, around a first pair of idle pulleys 11 which are fixed to the top part 12 of the lift housing structure. From this first pair of pulleys 11 the cables 2 pass around a second series of idle pulleys 13, the spindles 14 of which are fixed laterally to the cylinder/counterweight assembly 15, 16 and, from these

pulleys 13, the cables 2 lead to the anchoring means 204 on the ceiling 12 of the structure. The counterweight 15 must have a weight such as to counterbalance the weight of the lift cabin 1 plus part of carrying capacity.

[0013] In Figures 2 and 3 the hydraulic lift is shown in the position where the cabin 1 is completely lowered. In order to raise this cabin 1 up to the desired height it is required to pump hydraulic fluid from the union 18 which is situated at the base of the fixed riser 17 so that this fluid rises up along the longitudinal cavity 26 and reaches the diaphragm 221 of the fixed piston 121 and then flows through the apertures 24 into the cylindrical cavity 120. The increase in the fluid volume inside said cylindrical cavity 120 results in lowering of the movable cylinder 16 with the counterweight 15 and the idle pulleys 13. This lowering with simultaneous rotation of the idle pulleys 13, which are integral with the movable cylinder 16, causes raising of the cabin 1 up to the desired height. In order to lower the cabin 1 again it is sufficient to perform a reverse operation, identical to that described above, with pumping of hydraulic fluid from the union 19 which is positioned at the top of the fixed riser 17 and consequent filling of the top part of the cylindrical cavity 20. During these lowering and raising movements of the cabin 1 of the lift, advantageously the weight of the latter is counterbalanced by the counterweight 15 which is integral with the movable cylinder 16. In this way the power needed to raise and lower the cabin of the lift is up to one third less than the power needed to raise and lower the cabin of a conventional hydraulic lift.

[0014] Fig. 5 shows the hydraulic lift according to the invention, in which identical parts have the same numbers as that used in the above description. The central piston, which is positioned at half the height and concentric with the stems 171 and 172 of the tubular riser 17, is formed in this variant by two pistons 121 and 122 each equipped with a diaphragm 221 and 222. A chamber 300 is therefore formed between these diaphragms 221 and 222, resulting in a reduction in the working stroke of the cylinder 16; in fact, the greater the distance between the attachment point fixed to the top part 12 and the attachment point fixed to the bottom part 4, the greater will be the size of this chamber 300 between the diaphragms 221 and 222 of the two pistons 121 and 122 and the smaller will be the extension of the cylindrical cavities 20 and 120. In this way it is possible to adjust the working stroke of the cylinder so as to ensure mechanical stoppage of the cylinder at the end surfaces, without having to provide a cylinder/piston assembly especially for each use, but by constructing it in modular fixed sizes. The pressure of the hydraulic fluid inside the chamber 300 must always be less than or equal to the pressure inside the cavities 20 and 120 and therefore two non-return valves 30 and 31 are positioned on the diaphragms 221 and 222. These non-return valves 30 and 31 allow the hydraulic fluid which is present inside the chamber 300 to pass into the cavities 20 and 120 should the pressure of the fluid inside the chamber 300 be greater than the

pressure inside the cavities 20 and 120. Two cylindrical sleeves 250 and 251 are also formed in the vicinity of the ends of the cylinder 16. A series of radial apertures 230, 231 and 232 connecting the chamber 126 to the cylindrical cavity 20 are formed on the stem 172 in the vicinity of the piston 121, while a series of radial apertures 240, 241, 242 connecting the chamber 26 to the cylindrical cavity 120 are formed in the vicinity of the piston 122. During operation of the lift, in the same way as described with reference to the embodiment in Figs. 2 and 3, when for example the bottom end of the cylinder 16, which is assumed to be moving upwards, approaches the piston 122, the sleeve 251 will gradually obstruct the radial apertures 240, 241 and 242, damping the contact between this cylinder 16 and the piston 112. In entirely the same way, contact between the top end of the cylinder 16 and the piston 221 will be cushioned by gradual closing of the radial apertures 230, 231 and 232.

[0015] Fig. 4 shows a further constructional variant of the present hydraulic lift in which the cables 2 fixed to the cabin 1, once they have passed around the pulleys 11, are fixed directly to the cylinder 16 by means of the corresponding attachment points 32. This variant of the present lift may be used in the case where the distance between the attachment points on the top part 12 and the bottom part 4 is greater than twice the working stroke of the lift. With this variant it is also possible to reduce the weight of the counterweight by about half.

Claims

1. Hydraulic lift, comprising a fixed tubular riser (17) which is mounted, at its ends, by means of suitable connections, between the floor (4) of the lift cabin travel shaft and the ceiling (12) of said shaft and communicates at its ends with unions (18, 19) for supplying and discharging a hydraulic fluid; at least one fixed cylindrical piston (121) which is positioned half-way along the height concentrically with said tubular riser (17); at least one fixed diaphragm (221) which is situated at the height of said cylindrical piston (121) and which divides said tubular riser (17) into two chambers (26; 126) which are not interconnected; a cylinder (16) coaxial with said tubular riser (17) and defining a cylindrical cavity (20; 120) sealingly housing said fixed cylindrical piston (121); said cylinder (16) having a length equal to about half the length of said tubular riser (17) and said cylinder (16) being able to slide relative to said fixed piston (121) from one end to the other of said tubular riser (17); communication apertures (23; 24) on the two sides of said fixed piston (121) able to connect said two chambers (26, 126) of the tubular riser to said cylindrical cavity (20; 120) of the said movable cylinder (16); means for supplying alternately the pressurised fluid into said two chambers (26; 126) of the tubular riser (17) so as to cause said movable cylinder (16)

to slide upwards or downwards; at least one first pair of idle pulleys (11) which are each fixed to an anchoring point situated on the ceiling (12) of the travel shaft of the lift cabin (1); at least one second pair of idle pulleys (13) mounted on said movable cylinder and fixed in diametrically opposite positions relative thereto; at least one pair of cables (2) for suspending a cabin (1), which are secured at one end to the ceiling (12) and driven around said second pair of idle pulleys (13) and from the latter pass around said first pair of idle pulleys (11) and are then secured to the structure of the cabin (1), and means (15) for counterbalancing the weight of the cabin, which are fixed to said movable cylinder, **characterized in that** said hydraulic piston is formed by two pistons (121, 122) each equipped with an associated diaphragm (221, 222), an internal chamber (300) being formed between said pistons (121, 122) and at least one non-return valve (30, 31) being positioned in each of said diaphragms so as to connect said internal chamber (300) to said chambers (26, 126) formed in the tubular riser (17), a series of radial apertures (230, 231, 232, 240, 241, 242) being provided, in the vicinity of each of said pistons (121, 122), for connecting said chambers (126, 26) to said cylindrical cavities (20, 120), sleeves (250, 251) being positioned in the vicinity of the ends of the movable cylinder (16) so as to gradually close said radial apertures (230, 231, 232, 240, 241, 242).

2. Hydraulic lift according to Claim 1, **characterized in that** each of said fixed pistons (121, 122) comprises a peripheral cylindrical sleeve which divides said cylindrical cavity into two chambers (20, 120).
3. Hydraulic lift according to Claim 1, **characterized in that** said fixed piston (121) divides said cavity of the fixed tubular riser (17) into two chambers (26; 126).
4. Hydraulic lift according to Claim 1, **characterized in that** said cylindrical sleeve of the fixed piston (121) comprises seals (22).
5. Hydraulic lift according to Claim 1, **characterized in that** said movable cylinder (16) comprises seals (25) at its ends.
6. Hydraulic lift according to Claim 1, **characterized in that** the cables (2) fixed to the cabin (1), once they have passed around the pulleys (11), are fixed directly to the cylinder (16) by means of the corresponding attachment points (32).

Patentansprüche

1. Hydraulischer Aufzug, der aufweist: ein rohrförmiges Steigrohr (17), das an seinen Enden mittels geeig-

neter Verbindungen zwischen dem Boden (4) des Aufzugkabinenschachts und der Decke (12) des Schachts montiert ist und das an seinen Enden mit Rohrverbindungen (18, 19) in Verbindung steht, um eine Hydraulikflüssigkeit zuzuführen und abzuleiten; wenigstens einen festen zylindrischen Kolben (121), der auf halber Strecke entlang der Höhe konzentrisch mit dem rohrförmigen Steigrohr (17) positioniert ist; wenigstens eine feste Membran (221), die sich auf der Höhe des zylindrischen Kolbens (121) befindet und die das rohrförmige Steigrohr (17) in zwei Kammern (26; 126) teilt, die nicht miteinander verbunden sind; einen Zylinder (16), der coaxial mit dem rohrförmigen Steigrohr (17) ist und einen zylindrischen Hohlraum (20; 120) definiert, der den festen zylindrischen Kolben (121) abdichtend aufnimmt; wobei der Zylinder (16) eine Länge gleich etwa einer Hälfte der Länge des rohrförmigen Steigrohrs (17) hat und der Zylinder (16) fähig ist, relativ zu dem festen Kolben (121) von einem Ende des rohrförmigen Steigrohrs (17) zu dem anderen zu gleiten; Verbindungsöffnungen (23; 24) auf den zwei Seiten des festen Kolbens (121), die fähig sind, die zwei Kammern (26, 126) des rohrförmigen Steigrohrs mit dem zylindrischen Hohlraum (20; 120) des beweglichen Zylinders (16) zu verbinden; Einrichtungen zum abwechselnden Zuführen des unter Druck stehenden Fluids in die zwei Kammern (26; 126) des rohrförmigen Steigrohrs (17), um zu bewirken, dass der bewegliche Zylinder (16) aufwärts oder abwärts gleitet; wenigstens ein erstes Paar von beweglichen Rollen (11), die jeweils an einem Verankerungspunkt befestigt sind, der sich auf der Decke (12) des Fahr-schachts der Aufzugkabine (1) befindet; wenigstens ein zweites Paar von beweglichen Rollen (13), das auf dem beweglichen Zylinder montiert ist und relativ zu diesem in diametral entgegengesetzten Richtungen befestigt ist; wenigstens ein Paar von Kabeln (2) zum Aufhängen einer Kabine (1), die an einem Ende an der Decke (12) befestigt sind und um das zweite Paar von beweglichen Rollen (13) herum angetrieben werden und von dem Letzteren um das erste Paar von beweglichen Rollen (11) laufen und dann an der Struktur der Kabine (1) befestigt sind, und Einrichtungen (15) zum Ausgleichen des Gewichts der Kabine, die an dem beweglichen Zylinder befestigt sind, **dadurch gekennzeichnet, dass** der Hydraulikkolben durch zwei Kolben (121, 122) ausgebildet ist, die jeweils mit einer zugehörigen Membran (221, 222) verbunden sind, wobei eine Innenkammer (300) zwischen den Kolben (121, 122) ausgebildet ist und wenigstens ein Rückschlagventil (30, 31) in jeder der Membranen positioniert ist, um die Innenkammer (300) mit den Kammern (26, 126) zu verbinden, die in dem rohrförmigen Steigrohr (17) ausgebildet sind, wobei eine Reihe radialer Öffnungen (230, 231, 232, 240, 241, 242) in der Nachbarschaft jedes der Kolben (121, 122) bereitgestellt ist,

um die Kammern (126, 26) mit den zylindrischen Hohlräumen (20, 120) zu verbinden, wobei Manschetten (250, 251) in der Nachbarschaft der Enden des beweglichen Zylinders (16) positioniert sind, um die radialen Öffnungen (230, 231, 232, 240, 241, 242) allmählich zu schließen.

2. Hydraulischer Aufzug nach Anspruch 1, **dadurch gekennzeichnet, dass** jeder der festen Kolben (121, 122) eine zylindrische Umfangsmanschette aufweist, die den zylindrischen Hohlraum in zwei Kammern (20, 120) teilt.
3. Hydraulischer Aufzug nach Anspruch 1, **dadurch gekennzeichnet, dass** der feste Kolben (121) den Hohlraum des festen rohrförmigen Steigrohrs (17) in zwei Kammern (26; 126) teilt.
4. Hydraulischer Aufzug nach Anspruch 1, **dadurch gekennzeichnet, dass** die zylindrische Manschette oder der feste Kolben (121) Dichtungen (22) aufweist.
5. Hydraulischer Aufzug nach Anspruch 1, **dadurch gekennzeichnet, dass** der bewegliche Zylinder (16) Dichtungen (25) an seinen Enden aufweist.
6. Hydraulischer Aufzug nach Anspruch 1, **dadurch gekennzeichnet, dass** die an der Kabine (1) befestigten Kabel (2), wenn sie einmal um die Rollen (11) gelaufen sind, mit Hilfe der entsprechenden Befestigungspunkte (33) direkt an dem Zylinder (16) befestigt sind.

Revendications

1. Ascenseur hydraulique comprenant une colonne montante fixe (17) qui est montée, au niveau de ses extrémités, au moyen de raccords appropriés, entre le plancher (4) du puits de circulation de la cabine d'ascenseur et le plafond (12) dudit puits et communique, au niveau de ses extrémités, avec des embouts (18, 19) destinés à alimenter et à évacuer un fluide hydraulique ; au moins un piston cylindrique fixe (121) qui est positionné à mi chemin le long de la hauteur, de manière concentrique avec ladite colonne montante (17) ; au moins une membrane fixe (221) qui est située au niveau de la hauteur dudit piston cylindrique (121) et qui divise ladite colonne montante (17) en deux chambres (26 ; 126) qui ne sont pas interconnectées ; un vérin (16) coaxial avec ladite colonne montante (17) et définissant une cavité cylindrique (20 ; 120) qui abrite hermétiquement ledit piston cylindrique fixe (121) ; ledit vérin (16) ayant une longueur égale à environ la moitié de la longueur de ladite colonne montante (17) et ledit vérin (16) étant capable de coulisser par rapport au dit

piston cylindrique fixe (121) d'une extrémité à l'autre de ladite colonne montante (17) ; des ouvertures de communication (23 ; 24) sur les deux côtés dudit piston fixe (121) capable de raccorder lesdites deux chambres (26, 126) de la colonne montante à ladite cavité cylindrique (20 ; 120) dudit vérin mobile (16) ; un moyen permettant d'alimenter en alternance le fluide sous pression dans lesdites deux chambres (26 ; 126) de la colonne montante (17) de façon à provoquer le coulissement vers le haut ou vers le bas dudit vérin mobile (16) ; au moins une première paire de poulies folles (11) qui sont, chacune, fixées à un point d'ancrage situé sur le plafond (12) du puits de circulation de la cabine d'ascenseur (1) ; au moins une seconde paire de poulies folles (13) montées sur ledit vérin mobile et fixées dans des positions diamétralement opposées l'une par rapport à l'autre ; au moins une paire de câbles (2) permettant de suspendre une cabine (1), qui sont solidement fixés au niveau d'une extrémité au plafond (12) et entraînés autour de ladite seconde paire de poulies folles (13) et à partir de celles-ci, passent autour de ladite première paire de poulies folles (11) et sont ensuite solidement fixés à la structure de la cabine (1), et un moyen (15) permettant de contrebalancer le poids de la cabine, qui sont fixés au dit vérin mobile, **caractérisé en ce que** ledit piston hydraulique est formé par deux pistons (121, 122), chacun étant muni d'une membrane associée (221, 222), une chambre interne (300) étant formée entre lesdits pistons (121, 122) et au moins un clapet anti-retour (30, 31) étant positionné dans chacune desdites membranes de façon à raccorder ladite chambre interne (300) aux dites chambres (26, 126) formées dans la colonne montante (17), une série d'ouvertures radiales (230, 231, 232, 240, 241, 242) étant fournies, à proximité de chacun desdits pistons (121, 122), permettant de raccorder lesdites chambres (126, 26) aux dites cavités cylindriques (20, 120), des enveloppes (250, 251) étant positionnées à proximité des extrémités du vérin mobile (16) de façon à fermer progressivement lesdites ouvertures radiales (230, 231, 232, 240, 241, 242).

2. Ascenseur hydraulique selon la revendication 1, **caractérisé en ce que** chacun desdits pistons fixes (121, 122) comprend une enveloppe cylindrique périphérique qui divise ladite cavité cylindrique en deux chambres (20, 120).
3. Ascenseur hydraulique selon la revendication 1, **caractérisé en ce que** ledit piston fixe (121) divise ladite cavité de la colonne montante fixe (17) en deux chambres (26 ; 126).
4. Ascenseur hydraulique selon la revendication 1, **caractérisé en ce que** ladite enveloppe cylindrique du piston fixe (121) comprend des joints d'étanchéité

(22).

5. Ascenseur hydraulique selon la revendication 1, **caractérisé en ce que** ledit vérin mobile (16) comprend des joints d'étanchéité (25) au niveau de ses extrémités.
6. Ascenseur hydraulique selon la revendication 1, **caractérisé en ce que** les câbles (2) fixés sur la cabine (1), une fois qu'ils sont passés autour des poulies (11) sont fixés directement au vérin (16) au moyen des points d'attache (32) correspondants.

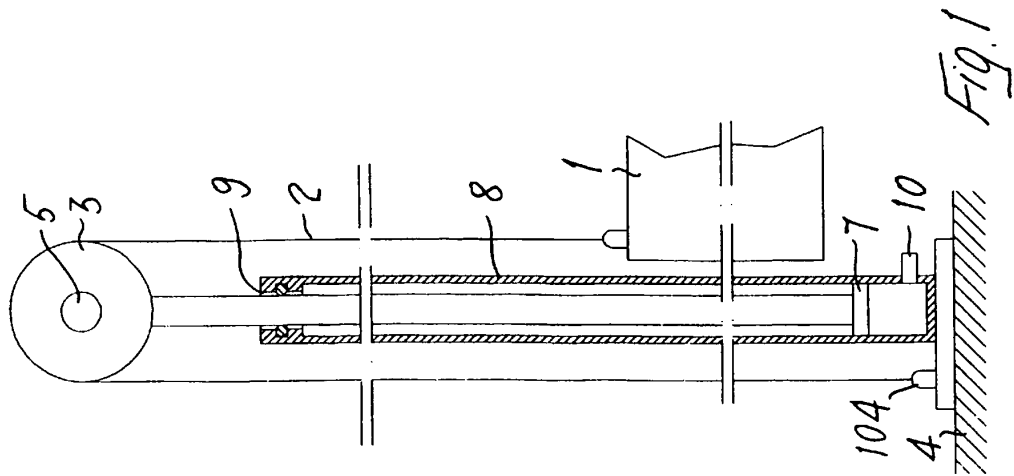
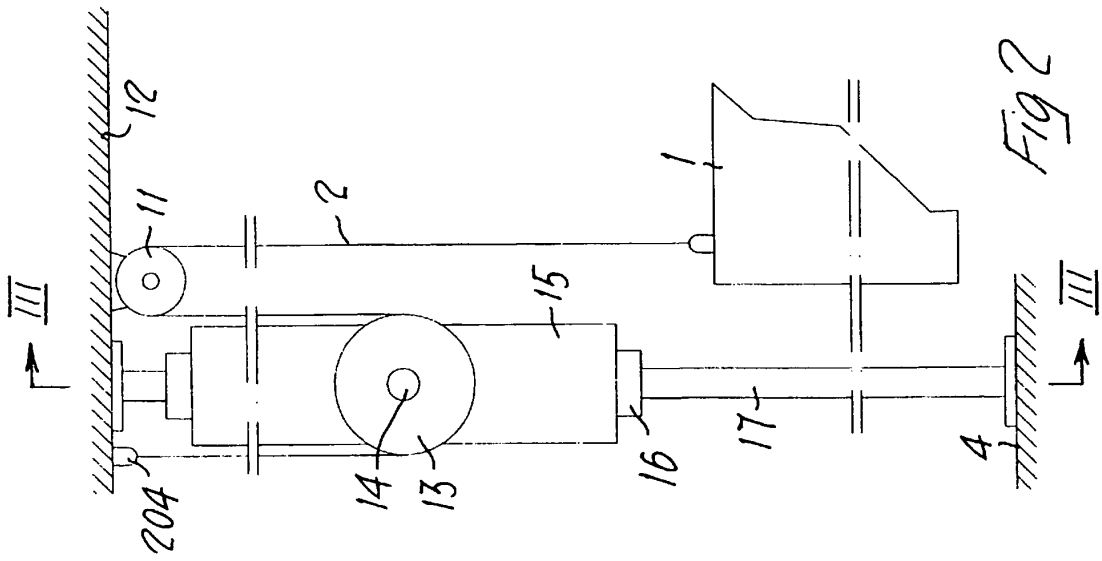

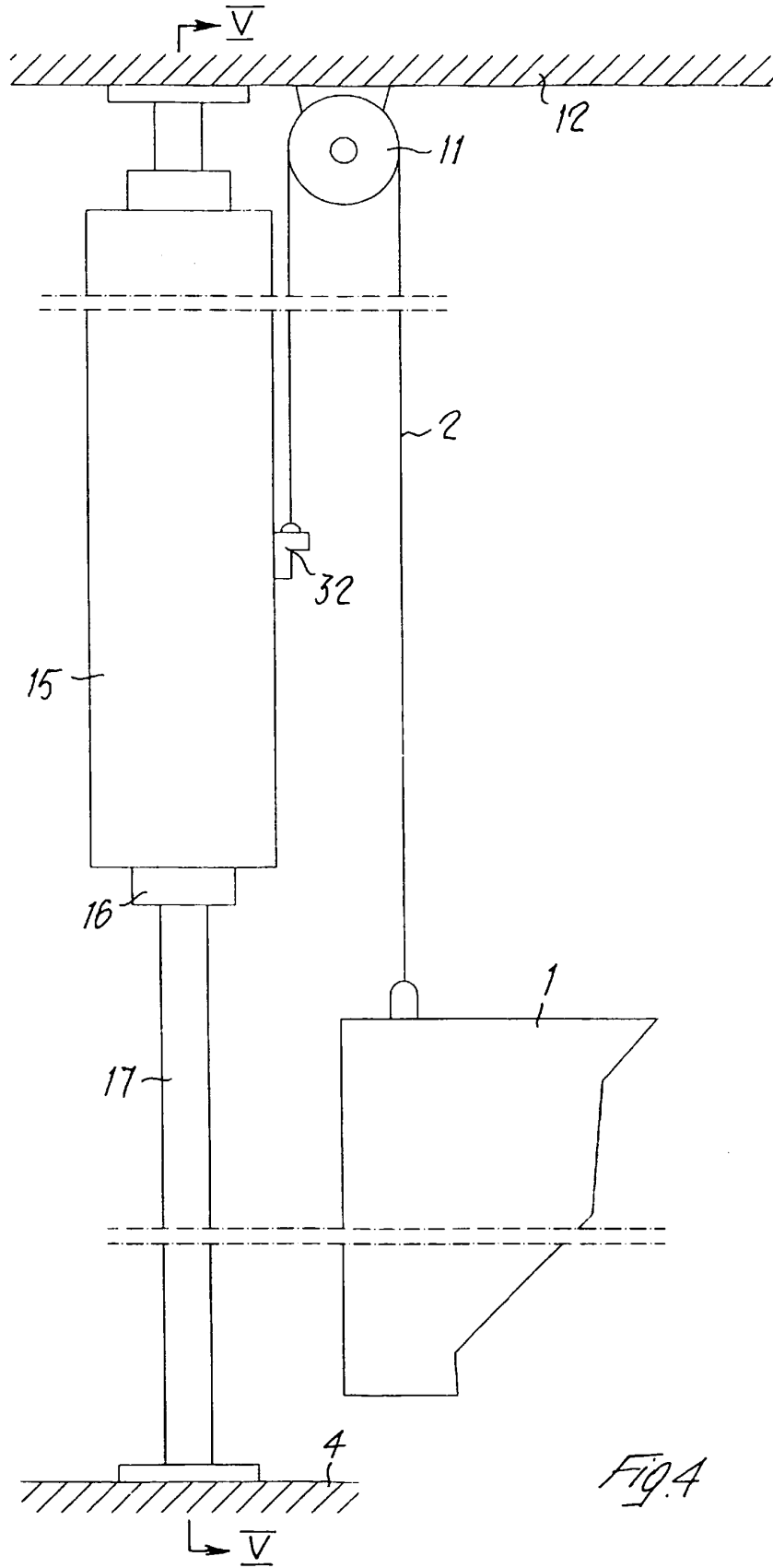

FIG. 4

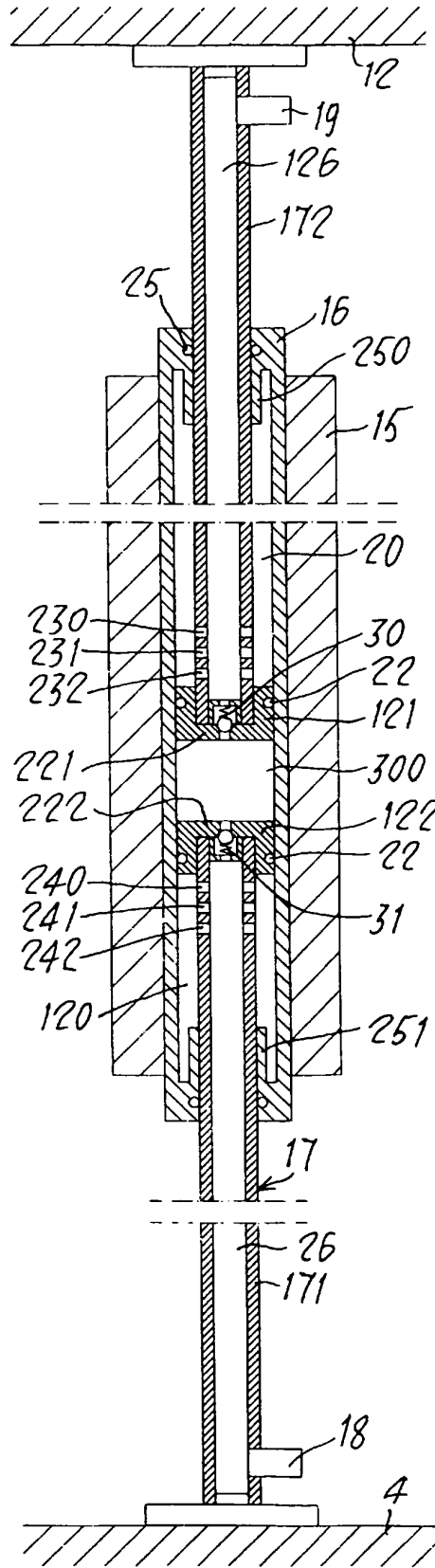

Fig. 5

REFERENCES CITED IN THE DESCRIPTION

This list of references cited by the applicant is for the reader's convenience only. It does not form part of the European patent document. Even though great care has been taken in compiling the references, errors or omissions cannot be excluded and the EPO disclaims all liability in this regard.

Patent documents cited in the description

- DE 3002577 A1 [0003]
- JP 2001063939 A [0004]
- WO 0071456 A1 [0005]
- EP 0254840 A2 [0006]