

F. KIENAST.
Clock Striking.

No. 108,362.

Patented Oct. 18, 1870.

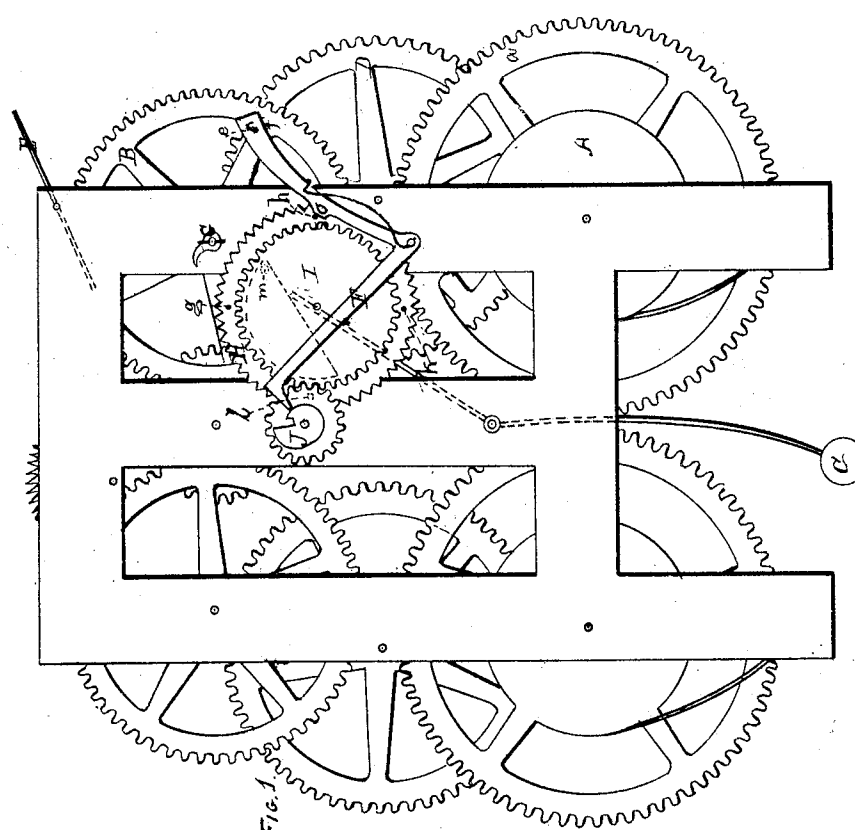
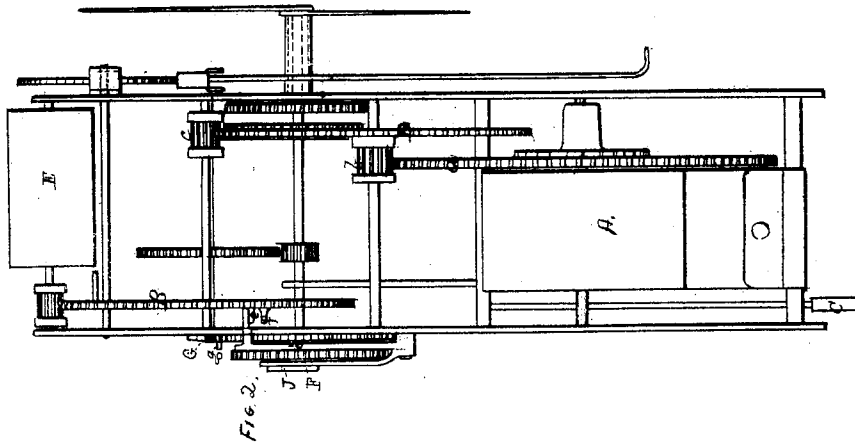

Witnesses
Wm. Machol
James W. Moulton

Frederick Kienast
By *David A. Poyacote* atty.

United States Patent Office.

FRIEDERICH KIENAST, OF ANSONIA, CONNECTICUT.

Letters Patent No. 108,362, dated October 18, 1870.

IMPROVEMENT IN THE STRIKING MOVEMENT OF CLOCKS.

The Schedule referred to in these Letters Patent and making part of the same.

To all whom it may concern :

Be it known that I, FRIEDERICH KIENAST, of Ansonia, in the county of New Haven, and State of Connecticut, have invented a new and useful improved Striking Attachment for Clocks; and I do hereby declare that the following is a full and exact description of the same, reference being had to the accompanying drawing and to the letters of reference marked thereon.

Figure 1 is a rear elevation of a clock-movement, with my improved striking device attached.

Figure 2 is an end or side elevation of the same.

Similar letters of reference, when they occur in the separate views, indicate like parts.

My invention relates to an improved striking-attachment for clocks, by the use of which I am enabled to do away with the catches, springs, and irregularly slotted or notched wheels, which are now used for such attachments, supplying their place with a regularly notched wheel, operated upon by a dog, and set in motion and stopped by a lever, acted upon by a cam upon the pointer-shaft.

The particular advantage obtained by my invention is, that instead of "striking around" the clock when it chances to stop or run down, the hands can be turned directly to the required point, and the correct hour will always be struck.

To enable others skilled in the art to make and use my invention, I will proceed to describe the construction and operation of the same, with reference to the accompanying drawing, and the letters of reference marked thereon.

A is the spring which drives the striking-attachment. A weight may be substituted in place of this spring if necessary.

B is a gear, upon one side of which one or more pins are placed, which, as the wheel revolves, operate upon and raise the hammer C, which is thrown back and against the bell after the pin passes by a spring, properly arranged for the purpose.

The wheel B is driven from the spring or weight by means of the gear *a*, attached to the spring and pinion *b*, and wheel D, upon an intermediate shaft.

The wheel B also operates the fly or regulator E, through the pinion *c*.

Upon the outer or front surface of the wheel B, two pins, *e* *f*, are placed, one of which strikes a projection upon the lever F, as will be more fully explained hereafter.

G is a dog, attached to the shaft of the wheel B, and operates the wheel H, placed upon the shaft *d* of the time-keeping portion of the clock.

The wheel H has forty-eight teeth or notches cut in its face, and upon its outer or front surface four pins, *g*, *h*, *k*, and *l*, quarterly dividing it.

The said wheel is placed loosely upon the shaft, and is operated by the pin *m*, in the wheel I, which gears directly with the pointer-shaft.

Upon the pointer-shaft, a cam, J, is placed, which is provided with one or more projections; one if only the hours are to be struck, and two or four when arranged to strike the half and quarter hours.

The said cam J operates upon one end of the lever F, while the projection at the other end operates upon the pins *e* and *f*, upon the wheel B, and acts as a stop to the said wheel.

As the pointers revolve, the projection upon the cam J raises the lever F, and allows the pin *e* to pass the projection on the said lever, which strikes the second pin, *f*.

The cam J is so arranged as to begin to raise the lever at about a quarter before striking. The gradual rising in this way causes less friction upon the different parts when the clock is preparing to strike, and this renders the movement more uniform and regular.

When the lever F falls into the indentation or lower portion of the cam, the said projection upon the lever F is lowered, so that the pin *f* also passes, and allows the wheel B to revolve, operating the dog G, attached thereto, upon the notched wheel H, moving it one notch at every revolution of the wheel B, which is continued until one of the pins *g*, *h*, *k*, or *l*, comes in contact with the boss *o*, upon the lever F, raising the said lever to its original position, which causes the pin *e* upon the wheel B to strike the projection on the lever stopping the said wheel, and the striking ceases.

The gear-wheel upon the pointer-shaft is provided with twenty-three teeth, the gear-wheel I with forty-eight, and the wheel H with forty-eight, the latter being divided by four pins into four sets of twelve each. It will be evident that, at each revolution of the pointer-shaft, which occurs once an hour, the wheel I will be moved twenty-three notches in its revolution.

The same movement, also, will be communicated to the wheel H, by means of the pin *m* in the wheel I, supposing, of course, that the pin *m* is bearing against the end of the slot in wheel H.

The wheel H, thus far, has moved one set of its notches, (twelve,) entirely by the boss *o*, on lever F, and another set entirely by, excepting one notch.

The lever being free to fall, the wheel B is allowed to revolve and turn the wheel H, by its dog G, one notch, when the last pin of the second series strikes the boss, and throws the lever into position to catch the wheel B.

Another hour passes, the wheel I is moved twenty-three notches again, but as the wheel H has been

moved one notch away from the pin *m* by the action of the dog *G*, it consequently is moved but twenty-two notches. This carries one series of its notches past the boss, and ten of another, leaving the last pin of the second series two notches away from the boss. This progressive movement continues until the number twelve has been reached, when, of course, the next revolution will cause the number one to be struck again.

It will be observed that there is a fixed relative movement between the pointer-shaft and the wheel *I*, and whether the clock is permitted to strike or not, they must necessarily always retain the same relation to one another.

Having thus fully described my invention,

What I claim as new, and desire to secure by Letters Patent of the United States, is—

1. The striking attachment described, consisting of the cam *J*, lever *F*, wheels *I*, *H*, and *B*, constructed as described, with their connections, when the parts are combined and arranged as described, for the purpose set forth.

2. The wheel *I*, with its pin, in combination with the wheel *H* and pointer-shaft, as described.

This specification signed and witnessed this 10th day of February, 1870.

FRIEDERICH KIENAST.

Witnesses:

JACOB FREEMAN,
FRANK PRESCOTT.