



INTERNATIONAL APPLICATION PUBLISHED UNDER THE PATENT COOPERATION TREATY (PCT)

<p>(51) International Patent Classification ⁶ ; H03M 7/30</p>	<p>A2</p>	<p>(11) International Publication Number: WO 97/32402 (43) International Publication Date: 4 September 1997 (04.09.97)</p>
--	-----------	---

(21) International Application Number: PCT/IB97/00125
 (22) International Filing Date: 13 February 1997 (13.02.97)
 (30) Priority Data:
 96200494.1 27 February 1996 (27.02.96) EP
 (34) Countries for which the regional or international application was filed: NL et al.
 (71) Applicant: PHILIPS ELECTRONICS N.V. [NL/NL]; Groenewoudseweg 1, NL-5621 BA Eindhoven (NL).
 (71) Applicant (for SE only): PHILIPS NORDEN AB [SE/SE]; Kottbygatan 7, Kista, S-164 85 Stockholm (SE).
 (72) Inventor: KALKER, Antonius, Adrianus, Cornelis, Maria; Prof. Holstlaan 6, NL-5656 AA Eindhoven (NL).
 (74) Agent: SCHMITZ, Herman, Jan, Renier; Internationaal Octrooibureau B.V., P.O. Box 220, NL-5600 AE Eindhoven (NL).

(81) Designated States: CN, JP, KR, European patent (AT, BE, CH, DE, DK, ES, FI, FR, GB, GR, IE, IT, LU, MC, NL, PT, SE).
Published
 Without international search report and to be republished upon receipt of that report.

(54) Title: METHOD AND ARRANGEMENT FOR CODING AND DECODING SIGNALS

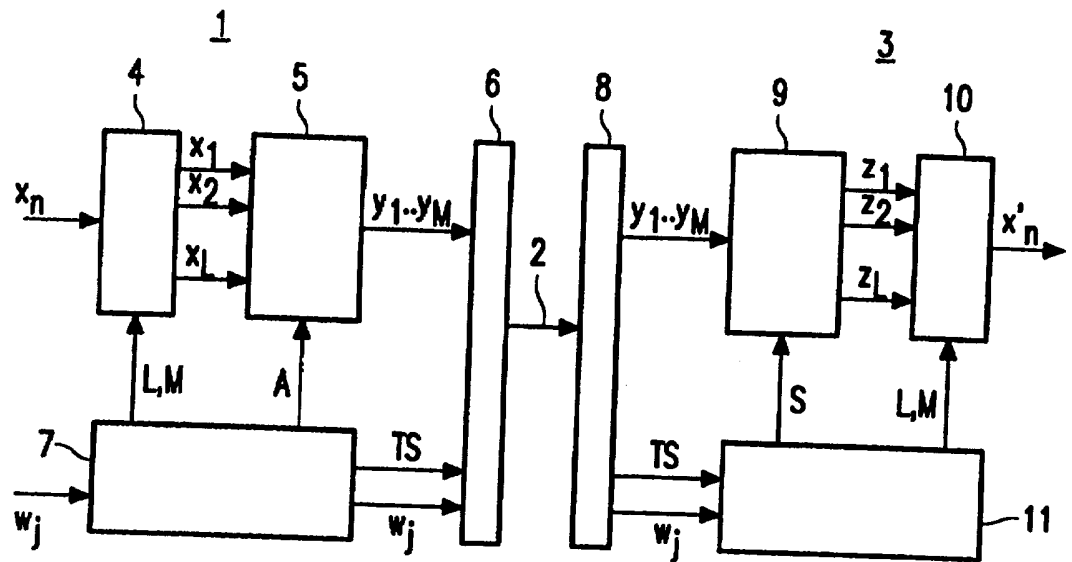

(57) Abstract

The invention offers the opportunity to build time-varying filter banks by gluing together stationary filter banks. This glue process can be arranged in such a manner that in an encoding environment a minimum overhead needs to be transmitted. Adaptive filter banks will probably assume an important position in new encoding standards such as, but not limited to, MPEG4.

FOR THE PURPOSES OF INFORMATION ONLY

Codes used to identify States party to the PCT on the front pages of pamphlets publishing international applications under the PCT.

AM	Armenia	GB	United Kingdom	MW	Malawi
AT	Austria	GE	Georgia	MX	Mexico
AU	Australia	GN	Guinea	NE	Niger
BB	Barbados	GR	Greece	NL	Netherlands
BE	Belgium	HU	Hungary	NO	Norway
BF	Burkina Faso	IE	Ireland	NZ	New Zealand
BG	Bulgaria	IT	Italy	PL	Poland
BJ	Benin	JP	Japan	PT	Portugal
BR	Brazil	KE	Kenya	RO	Romania
BY	Belarus	KG	Kyrgyzstan	RU	Russian Federation
CA	Canada	KP	Democratic People's Republic of Korea	SD	Sudan
CF	Central African Republic	KR	Republic of Korea	SE	Sweden
CG	Congo	KZ	Kazakhstan	SG	Singapore
CH	Switzerland	LI	Liechtenstein	SI	Slovenia
CI	Côte d'Ivoire	LK	Sri Lanka	SK	Slovakia
CM	Cameroon	LR	Liberia	SN	Senegal
CN	China	LT	Lithuania	SZ	Swaziland
CS	Czechoslovakia	LU	Luxembourg	TD	Chad
CZ	Czech Republic	LV	Latvia	TG	Togo
DE	Germany	MC	Monaco	TJ	Tajikistan
DK	Denmark	MD	Republic of Moldova	TT	Trinidad and Tobago
EE	Estonia	MG	Madagascar	UA	Ukraine
ES	Spain	ML	Mali	UG	Uganda
FI	Finland	MN	Mongolia	US	United States of America
FR	France	MR	Mauritania	UZ	Uzbekistan
GA	Gabon			VN	Viet Nam

Method and arrangement for coding and decoding signals.

FIELD OF THE INVENTION

The invention relates to a method and arrangement for coding and decoding signals such as picture or sound signals by means of a lapped transform. More particularly, the invention relates to a method and system wherein different transforms are used for different segments of the picture or sound signal.

5

BACKGROUND OF THE INVENTION

By transforming a picture or sound signal, samples of the signal are transformed into coefficients. The coefficients are transmitted and subsequently backward-transformed to reconstruct the samples of the picture or sound signal. Both the forward
10 transform at the transmitter end and the backward transform at the receiver end are defined by a transform matrix.

In a non-lapped transform such as the Discrete Cosine Transform (DCT) which is widely used in image coding, series of L samples are transformed into the same number of coefficients. From each series of coefficients, the corresponding series of samples
15 can be reconstructed by a backward transform at the receiving end. The forward and backward transform matrices have a dimension of $L \times L$ elements.

In a lapped transform, overlapping series of samples of the signal are transformed into a number coefficients less than the number of samples. For example, series of L samples partly overlapping each other are transformed into M coefficients. The
20 transform matrix at the transmitter end and the receiver end have a dimension of $M \times L$ elements.

A signal transform may also be considered as a special case of filter bank coding. For example, the above-mentioned lapped transform may be implemented by a filter bank comprising M filters each having a filter length L . The filtered signals are decimated by
25 a factor M which means that only each M th sample of the filtered signals constitutes a coefficient which is transmitted while the intermediate $M-1$ samples are ignored. At the receiver end, the M coefficients are up-sampled (filling in the $M-1$ intermediate samples of

the value zero) and then applied to M interpolation filters each having a filter length L. The interpolated signals are subsequently summed in an adder.

By a transform, the input signal is decomposed into a weighted sum of basis functions, the coefficients constituting the weighting factors. The rows of the transform matrix or, equivalently, the impulse response functions of the interpolation filters of the filter bank constitute the basis functions. Each basis function has a frequency spectrum. Generally, the basis functions are chosen to be such that each basis function comprises a part of the total frequency spectrum.

Currently, segmentation based coding systems are envisaged in which different segments (e.g. subpictures of an image) are subjected to different transforms, for example in response to characteristics of a picture signal. One segment of the signal may be subjected to a first transform whereas a different second transform may be desired for a subsequent segment of the signal. A different transform is not only understood to mean a different transform matrix size but also a same matrix size with different element values. Switching from one transform to another does not cause any problem in a transmission system employing a non-lapped transform, because each series of samples can be reconstructed from the same number of coefficients, provided that the actual transform is known at the receiver end. However, problems do arise in transmission systems employing the lapped transform. Signal samples at the transition can not be reconstructed from the coefficients obtained by different transforms without complications. Similar problems arise at the boundary of signals having a finite extent, such as picture signals.

OBJECT AND SUMMARY OF THE INVENTION

It is an object of the invention to provide a method for encoding and decoding picture or sound signals in which the above mentioned problems are alleviated.

In accordance with the invention, the method of coding the signal is characterized by subjecting the signal samples forming the transition from the first to the second series of samples to an intermediate transform, said intermediate transform being determined by weighting factors indicating to what extent the frequency spectra of the basis functions of said intermediate transform resemble the frequency spectra of the first and second transform, and accommodating said weighting factors in the encoded signal.

The invention provides a solution for the following problem. It has turned out there are many candidate transform matrices for the transform of samples forming the transition from the first to the second series of signal samples. Not all the candidates are

equally favourable with respect to smoothness of reconstruction, quality of frequency separation, energy preservation, etc. The intermediate transform eventually selected by the transmitter is therefore to be transmitted to the receiver and thus to be accommodated in the transmitted signal. The transmission of the selected intermediate transform matrix requires a significant overhead because the matrix comprises a plurality of floating point numbers, a small deviation in which may cause significant reconstruction errors. This problem is solved by using weighting factors to indicate to what extent the frequency spectra of the basis functions of the intermediate transform have to resemble the corresponding frequency spectra of the first and second transform. The weighting factors may be different for different basis functions. For example, a higher weight may be given to the DC coefficient (the transform coefficient associated with the first order basis function) than to lower order coefficients. The weighting factors are transmitted to a receiver. Using the transmitted weighting factors, the receiver can calculate the inverse intermediate transform.

15 BRIEF DESCRIPTION OF THE DRAWINGS

Fig.1 shows a first embodiment of a system for transmitting picture or sound signals according to the invention.

Fig.2 shows a further embodiment of system for transmitting picture or sound signals according to the invention.

20 Figs. 3-11 show diagrams to illustrate the operation of transform control circuits which are shown in Figs. 1 and 2.

DESCRIPTION OF PREFERRED EMBODIMENTS

Fig.1 shows a first embodiment of a system for transmitting picture or sound signals according to the invention. The system comprises an encoding station 1, a transmission medium 2, and a decoding station 3. The transmission medium may be a radio or cable connection, but also a storage medium such as a magnetic tape or optical disc.

The transmitting station comprises a shift register 4 for series-to-parallel conversion of successive samples x_n of an input signal. The shift register is programmable in the sense that the number L of stages and the number M of samples by which the input signal is shifted, is programmable. The L available samples are denoted $x_1 \dots x_L$. They are applied to a transformer 5 in which the vector $x_1 \dots x_L$ is multiplied by an $M \times L$ transform matrix A. Each transform of L input samples yields M coefficients $y_1 \dots y_M$. After

quantization and encoding (not shown), they are applied to the transmission medium via a multiplexer 6.

In accordance with the invention, different transforms are applied to different segments of the input signal, for example, in response to local characteristics of the video image to be transmitted. To that end, the transmitting station further comprises a transform controller 7 which applies the actual transform matrix A to be used to transformer 5. In practical compression systems, the transform matrix will be a selected one from a plurality of predetermined matrices. The controller applies a transform selection signal TS to the multiplexer 6 so as to inform the receiver which transform is used by the transmitter and, accordingly, which backward transform is to be used at the receiving end. The controller also applies the programmable parameters L and M (i.e. the matrix dimensions), to the shift register 4.

In the receiving station 3, a demultiplexer 8 applies the received coefficients $y_1..y_M$ to a backwards transformer 9 which multiplies each series $y_1..y_M$ of M coefficients by an L*M matrix S. The transform of the M coefficients yields L intermediate sample values $z_1..z_L$. In an overlapped adding circuit 10, successive series of L sample values are added together in an overlapping manner to obtain reconstructed signal samples x'_n .

The receiving station further includes a transform controller 11 which receives, inter alia, the transform selection signal TS and selects, in response thereto, the transform matrix S to be used by transformer 9. The controller further applies the parameters L and M associated with matrix S, to the adding circuit 10.

Nowadays it is realised that a signal transform may essentially be considered as a special case of multirate filter bank coding. Such a multirate filter bank is shown in Fig.2 as a second embodiment of a system according to the invention. The filter bank of transmitting station 1 comprises M filters 12a..12m each having a filter length L and a transfer function $H_m(z)$. The filtered signals are decimated by a factor M in down-samplers 13a..13m. This is generally referred to as critical sampling. It means that only each Mth sample of the filtered signals is transmitted while the intermediate M-1 samples are ignored. Each transmitted sample represents a coefficients y_m ($m=1..M$). After quantization and transmission (not shown), the coefficients are transmitted via the multiplexer 6.

The transmitting station further comprises the same transform controller 7 as shown in Fig.1. The controller applies the actual filter coefficients $a_{l,m}$ (corresponding

with the elements of matrix A in Fig.1), the number of filters M , and the filter length L to be used, to the filters $12a..12m$. The controller also applies the transform selection signal TS to the multiplexer 6 so as to inform the receiver which type of backward transform is to be used at the receiving end.

5 In the receiving station 2 , the M signals are up-sampled (filling in the $M-1$ intermediate samples of the value zero) in up-samplers $14a..14m$. Subsequently, they are applied to M interpolation filters $15a..15m$ having a filter length L and a transfer function $F_m(z)$. The interpolated signals are subsequently summed in an adder 16 . Transform controller 11 applies the actual filter coefficients $s_{i,m}$ (corresponding with the elements of matrix S in Fig.1), the number M of filters, and the filter length L to the filters $15a..15m$.
10

The analogy between transform (Fig.1) and multirate filter bank coding (Fig.2) provides the possibility of gaining an insight into some aspects of the invention. For example, the M pulse responses having a length L of the interpolation filters $F_m(z)$ correspond to the M rows of the $M*L$ transform matrix S , and the M pulse responses having a length L of the filters $H_m(z)$ correspond to the rows of the matrix A which are reversed in order.
15

The features of the invention reside in the operation of transform controllers 7 and 11 . To better understand these operations, signal transforms in general will be elucidated first. We will concentrate on one-dimensional transforms. Two-dimensional transforms (for example, of two-dimensional picture blocks) are generally separable, which means that they can be performed by performing a first one-dimensional transform in the horizontal direction and a second one-dimensional transform in the vertical direction.
20

The picture or sound signal to be transmitted comprises a finite number N of samples x_n . The forward transform at the transmitter end converts them into an equal number N of coefficients y_n . These coefficients are transmitted and backward-transformed at the receiver end. The forward and backward transforms are laid down in an $N*N$ transform matrix.
25

In the practical systems shown in Figs. 1 and 2, the input signal $x_1..x_N$ is split up into series with a relatively small number L of samples, each series being subjected to the same transform. Due to this division, the $N*N$ transform matrix acquires a block-Toeplitz structure having relatively small matrices along the diagonal and zeroes elsewhere. In non-lapped transforms such as the generally known Discrete Cosine Transform (DCT) used for MPEG coding of picture signals, concatenated series of L samples are transformed into series of L coefficients by means of an $L*L$ matrix. At the receiver end, each series of
30

L samples can be reconstructed from the respective series of L coefficients. In lapped transforms, overlapping series of L samples are transformed into series of M (less than L) coefficients by means of an M*L matrix. After each transform, the input signal shifts by M samples. The M*L matrices overlap each other partly in the Toeplitz structure. To
 5 reconstruct a sample, the coefficients of all transforms which have been applied to series of samples comprising said sample are now to be taken into account. From each received L coefficients, M samples can be reconstructed.

Fig.3 shows an N*N transform matrix **30** for lapped transforming N samples $x_n, n=1..N$). The matrix comprises a plurality of identical M*L matrices **20** along
 10 the diagonal, these matrices partly overlapping each other. The matrix **20** is referred to as stationary matrix. In the present example, the stationary matrix **20** in Fig.3 will be assumed to have 2 rows (M=2) of 6 elements (L=6). As shown in the Figure, this matrix can be written in the form [A2 A1 A0].

In view of the similarity between a signal transform and multirate filter
 15 bank coding, the stationary M*L matrix may also be considered to represent a filter bank having M filters of length L. In accordance herewith, a matrix will also be referred to as filter bank or 'filters', for short.

In Fig.3, a single stationary matrix **20** is used for transforming the input signal. Switching from a first stationary matrix to a different second matrix will be dealt with
 20 later. The transform of the finite length input signal $x_1..x_N$ may not start and end with the stationary filter **20**. Otherwise, the transform matrix **30** is not invertible which means that the data samples at the boundaries cannot be reconstructed from the coefficients. Accordingly, so-called boundary filters **21** and **22** are to be used at the left and right boundary, respectively, of the input signal. An aspect of the invention relates to the problem of finding
 25 suitable boundary filters.

Boundary filters

In order to find suitable boundary filters, a first operation will be described in which boundary filters are computed which allow perfect or near perfect
 30 reconstruction of the data samples at the boundaries of the input signal. The filters thus found will appear to be not favourable with respect to coding efficiency (i.e. with respect to frequency separation) and hardware complexity. A second operation will be described in which these filters are converted into optimal boundary filters which are as similar as possible to the stationary filters.

First, the finite input signal x_1 is assumed to be extended with zeroes at both ends and the stationary transform is applied to the extended signal as far as necessary. This is illustrated in Fig.4 in which reference numerals **20'** denote repetitions of stationary filter **20** along the diagonal. Said repetitions are carried out until they no longer affect the transform of the samples $x_1 \dots x_N$.

Intuitively, it is expected that the left boundary filter will in some manner be related to the matrix which is denoted **23** in Fig.4. Matrix **23** has the size L-M and can be written as:

$$\begin{bmatrix} A0 & 0 \\ A1 & A0 \end{bmatrix}$$

Similarly, the right boundary filter will be related to the matrix which is denoted **24** in Fig.4. Matrix **24** also has the size L-M and can be written as:

$$\begin{bmatrix} A2 & A1 \\ 0 & A2 \end{bmatrix}$$

Matrices **23** and **24** themselves are not suitable to be boundary filters. This follows already from the fact that the transform matrix **40** shown in Fig.4 has L-M more rows than columns, which means that transforming the N relevant samples x_n will yield L-M more coefficients y_n than necessary.

The first operation involves determining the rank m_0 (i.e. the number of independent rows) of matrix **23**, and rotating (i.e. multiplying with an orthogonal rotating matrix R) said matrix to obtain m_0 non-zero rows. The non-zero part of the product matrix will be denoted B0. Hence:

$$[R] \times \begin{bmatrix} A0 & 0 \\ A1 & A0 \end{bmatrix} = \begin{bmatrix} 0 \\ B0 \end{bmatrix}$$

The same rotation R applied to matrix **24** yields a product matrix having m_1 non-zero rows. The non-zero part of said matrix will be denoted B1. Hence:

$$[R] \times \begin{bmatrix} A2 & A1 \\ 0 & A2 \end{bmatrix} = \begin{bmatrix} B1 \\ 0 \end{bmatrix}$$

The matrix R can be computed using the Procrustes algorithm as given in: Gene H. Golub and Charles F. van Loan: Matrix Computations; The John Hopkins University Press, Baltimore and London, 2nd edition, 1989.

The matrices B0 and B1 thus obtained can be used as boundary filter banks 21 and 22 (see Fig.3). However, the above described operation does not give a unique solution, let alone that the filter banks are favourable in terms of frequency separation. Furthermore, the matrices B0 and B1 are not attractive from a hardware point of view, because the number of filters (m_0 and m_1 , respectively) generally differs from the number of filters (M) in the stationary filter bank 20. In the present example where the stationary filter has two filters (M=2), the boundary filter banks B0 and B1 comprise one and three filters, respectively ($m_0=1$, $m_1=3$).

In view of a practical hardware implementation, the number of filters in each boundary filter bank is chosen to be an integer multiple of M. A single filter bank with programmable coefficients can then be used. To this end, an adequate number s_0 of orthogonal rows and columns are added to matrix B0, and an adequate number s_1 of orthogonal rows and columns are added to matrix B1. This is illustrated in Fig.5 in which reference numerals 25 and 26 denote the matrices thus enlarged. They can be written as:

$$\begin{bmatrix} I0 & 0 \\ 0 & B0 \end{bmatrix} \text{ and } \begin{bmatrix} B1 & 0 \\ 0 & I1 \end{bmatrix}, \text{ respectively.} \quad (\text{Eq. 1})$$

Herein, I0 is an identity matrix of size s_0 and I1 is an identity matrix of size s_1 . In mathematics, the numbers s_0 and s_1 are referred to as padding factors. In the example of Fig.5, the matrices 25 and 26 have M and 2M rows, respectively. They can be used as boundary filter banks but are still not favourable in terms of frequency separation.

In the second operation, matrices 25 and 26 are rotated, by multiplication with respective rotation matrices R0 and R1, to obtain boundary filter banks which better fulfil the condition of adequate frequency separation. Said boundary filter banks are denoted 27 and 28 in Fig.6. They can be written as

$$[R0] \times \begin{bmatrix} I0 & 0 \\ 0 & B0 \end{bmatrix} \text{ and } [R1] \times \begin{bmatrix} B1 & 0 \\ 0 & I1 \end{bmatrix}, \text{ respectively.}$$

The filters must exhibit a frequency separation behaviour as similar as possible with the stationary part of the transform matrix. In the present example, the two

filters in the left boundary filter bank 27 must resemble the two filters in stationary filter bank 20 in terms of frequency spectrum. The four filters in the right boundary filter bank 28 must resemble the four filters in two successively operated stationary filter banks 20 (denoted 29 in Fig.6).

5 The inventor has found that optimal rotation matrices R0 and R1 exist for a given weighted MSE (mean square error) in the frequency domain of the distance between the boundary filters and the stationary filter bank. The computation of R0 and R1 will now be described in more general terms. To that end, the above equations are generalised to represent a product matrix RB. Rotation matrix R is to be found such that the basis functions
10 of RB optimally resemble (in terms of frequency spectrum) the basis functions of a given stationary matrix, say S, having the same number of rows. The computation of R involves many but straightforward arithmetic operations, which will now be described.

Stationary matrix S is Fourier transformed into a matrix C=SF (F denotes the Fourier transform) having elements $c_{i,j}$ in the frequency domain. Similarly, boundary
15 filter bank RB is Fourier transformed into a matrix D=RBF having elements $d_{i,j}$ in the frequency domain. The length of boundary filter bank RB is hereby thought to be filled up with zeroes (extending a filter with zeroes causes the filter's frequency spectrum to be defined by more samples).

The weighted mean square error MSE_i in the frequency domain of the
20 distance between the spectrum of the i-th row of the boundary filter bank and the spectrum of the i-th row of the stationary filter bank is expressed as:

$$MSE_i = \sum_j w_j (c_{i,j} - d_{i,j})^2$$

in which w_j is a weighting factor which is selected for each basis function and, as shown in Figs. 1 and 2, transmitted to the receiver. MSE_i is to be minimised for each basis function of
25 the boundary filter bank, thereby keeping in mind that $c_{i,j}$ is known for a given stationary filter bank S whereas $d_{i,j}$ defines the boundary filter bank RB being looked for. It is known that minimising MSE_i corresponds with maximising the product term:

$$\sum_j w_j c_{i,j} d_{i,j}$$

Maximising the above product term is mathematically similar to
30 maximising the sum over the diagonal of the matrix RBFWF*S* (* denotes transposition) in

which W is a diagonal matrix having the weighting factors w_j as diagonal, S represents the given stationary filter bank, B has already been calculated in the first operation (see Eq.1), and F denotes the Fourier transform. Thus, the product matrix $BFWF^*S^*$ is given.

Any matrix E can be written as a product $E=U\Lambda V^*$ in which U and V are energy preserving matrices and Λ is a diagonal matrix. In matrix computations this decomposition of matrix E is referred to as Singular Value Decomposition (SVD). Reference is made to Gene H. Golub and Charles F. van Loan: Matrix Computations, already mentioned hereinbefore. It is further known that the sum over the diagonal of $RE=RU\Lambda V^*$ is maximal for $R=VU^*$. In accordance herewith, applying the SVD method to the matrix $BFWF^*S^*$ yields matrices U and V and, consequently, the rotation matrix $R=VU^*$ for which the sum over the diagonal of $RBFWF^*S^*$ is maximal.

The SVD method is applied to both boundaries of the input signal. In the present example, rotation matrix R_0 (and thus boundary filter **27** in Fig.6) is found by applying SVD to the matrix

$$BFWF^*S^* = \begin{bmatrix} I_0 & 0 \\ 0 & B_0 \end{bmatrix} \times F \times W \times F^* \times [A_2 \ A_1 \ A_0]^*$$

Similarly, rotation matrix R_1 (and thus boundary filter **28** in Fig.6) is found by applying SVD to the matrix

$$BFWF^*S^* = \begin{bmatrix} B_1 & 0 \\ 0 & I_1 \end{bmatrix} \times F \times W \times F^* \times \begin{bmatrix} A_2 & A_1 & A_0 \\ 0 & A_2 & A_1 \end{bmatrix}^*$$

In the present example, boundary filter bank **28** comprises $2M=4$ filters. As expected in view of the similarity with matrix **29** shown in Fig.6, the first coefficients of the 3rd and 4th filter will appear to be small. They may be replaced by zeroes, in which case the boundary filter bank **28** corresponds with two successively operated overlapped transforms **28'** and **28''**. Both boundaries can now efficiently be processed by a single filter bank having M filters with L programmable filter coefficients.

Fig.7 shows the frequency responses of the left boundary filter bank (A), the stationary filter bank (B) and the right boundary filter bank (C) in the case that the stationary filter bank is a 2-channel Daubechies length 6 wavelet filter ($M=2$, $L=6$). The boundary filters are designed to match the frequency characteristics of the stationary filter with a very large weight for the DC coefficient. The Figure shows that the boundary filters

are bad behaved in the sense that there is not a clear low pass and a clear high pass filter on both sides. The results illustrate that is not always possible to design excellent boundary filters.

5 Transition filters

Currently, (image) coding systems are envisaged in which different segments of the input signal are subjected to different transforms, for example in response to local characteristics of a picture signal. One segment of the signal may be subjected to a first lapped transform whereas a second lapped transform is desired for a subsequent segment of the signal. Fig.8 shows the relevant part of the Toeplitz transform matrix. In this Figure, X and Y denote the first and second stationary transform matrix, respectively. By way of example, X is assumed to be a 2*6 matrix whereas Y is a 3*9 matrix. It is important to realize that abruptly switching from filter bank X to filter bank Y (as shown by dotted lines in the Figure) constitutes a non-invertible transform. Accordingly, intermediate or transient filters (collectively denoted **80** in Fig.8) are to be used.

A further aspect of the invention relates to the problem of finding suitable transition filters which allow a smooth transition from one stationary filter bank to another while preserving coding efficiency (good frequency separation).

A possible strategy for switching from one stationary filter bank to another is using a right boundary filter to close the transform of a segment and using a left boundary filter to start the transform of the next segment. This strategy is illustrated in Fig.9 wherein T1 denotes a right boundary filter relating to stationary transform X (cf. **28** in Fig.6), and T0 denotes a left boundary filter relating to stationary transform Y (cf. **27** in Fig.6).

The above strategy is less attractive because, as already mentioned above, boundary filters are not always excellent in terms of coding efficiency. The design of a better behaving transition filter will now be described. The design comprises the same operations as described before with reference to the boundary filters. The first operation yields boundary filters

$$30 \quad \begin{bmatrix} B1 & 0 \\ 0 & I1 \end{bmatrix} \text{ and } \begin{bmatrix} I0 & 0 \\ 0 & B0 \end{bmatrix}, \text{ respectively,}$$

in accordance with Eq.1. They are shown in Fig.10. The second operation comprises rotation of said boundary filters to obtain optimal filters. However, whereas said rotation was previously applied to individual boundary matrices, the operation is now applied to a matrix B denoted **90** in Fig.10, which covers both boundary filters. A significant advantage over the design of boundary filters is that rotation of matrix **90** may now create non-zeroes beyond the boundaries, i.e. within the matrix areas denoted **91** and **92** in Fig.10. It is this degree of freedom which allows transient filters to behave considerably better than boundary filters.

Briefly summarizing the second operation, the transition matrix B denoted **90** in Fig.10 is rotated by multiplication with an orthogonal matrix R. The rotation matrix R is to be found such that the product matrix RB exhibits a frequency separation behaviour as similar as possible with matrix **80** (see Fig.8) which, in the present example, comprises two successively operated stationary filters X and one operation of stationary filter Y.

The rotating matrix R is calculated such that the weighted mean square error MSE_i in the frequency domain of the distance between the spectrum of the i-th row of the transition filter and the spectrum of the i-th row of filter bank **80** is minimised for each basis function. The rotation matrix is calculated by applying the SVD method as already described before with reference to boundary filters. In accordance with the invention, the weighting factors used in the SVD calculation are transmitted to the decoder to allow said decoder to calculate the transition filter.

Fig.11 shows the frequency responses of a first stationary filter bank (A), three successive operations (B, C, D) of a transition filter, and a second stationary filter bank (E). In this example, the first stationary filter bank (A) is a 2-channel Daubechies length 6 wavelet filter ($M=2, L=6$) and the second stationary filter bank (E) is a 2-channel Daubechies length 8 wavelet filter ($M=2, L=8$). The transition filters are designed to match the frequency characteristics of the stationary filters with a very large weight for the DC coefficient. In contrast to Fig.7, the transition filter banks have a clear low-pass and high-pass characteristic, and exhibit a gradual change from the first to the second stationary impulse responses.

Claims

1. A method of transform coding a signal, comprising the steps of subjecting a first series of samples of the signal to a first lapped transform and a second series of samples of the signal to a second lapped transform, characterized by subjecting signal samples forming the transition from the first to the second series of samples to an intermediate transform, said intermediate transform being determined by weighting factors indicating to what extent the frequency spectra of the basis functions of said intermediate transform resemble the frequency spectra of the first and second transform, and accommodating said weighting factors in the encoded signal.
2. A method of decoding a transform coded signal of which a first series of samples has been subjected to a first lapped transform and a second series of samples has been subjected to a second lapped transform, characterized by applying an intermediate transform to decode signal samples forming the transition from the first to the second series of samples, said intermediate transform being determined by received weighting factors indicating to what extent the frequency spectra of the basis functions of the intermediate transform resemble the frequency spectra of the first and second transform.
3. An arrangement for transmitting a signal, comprising transform means for subjecting a first series of samples of the signal to a first lapped transform and a second series of samples of the signal to a second lapped transform, characterized by transform control means arranged to control the transform means to subject signal samples forming the transition from the first to the second series of samples to an intermediate transform, said intermediate transform being defined by weighting factors indicating to what extent the frequency spectra of the basis functions of said intermediate transform have to resemble the frequency spectra of the first and second transform, and to transmit said weighting factors to a receiver.
4. An arrangement for decoding a transform coded signal of which a first series of samples has been subjected to a first lapped transform and a second series of

samples has been subjected to a second lapped transform, comprising transform means for transforming the encoded signal into signal samples, characterized by transform control means arranged to control the transform means to apply an intermediate transform to obtain signal samples forming the transition from the first to the second series of samples, said
5 intermediate transform being defined by received weighting factors indicating to what extent the frequency spectra of the basis functions of the intermediate transform resemble the frequency spectra of the first and second transform.

5. An encoded signal, comprising first transform coefficients representing a
10 first series of samples of said signal in accordance with a first transform and second transform coefficients representing a second series of samples of said signal in accordance with a second transform, characterized in that the encoded signal comprises intermediate transform coefficients representing signal samples forming the transition from the first to the second series in accordance with an intermediate transform, and weighting factors indicating
15 to what extent the frequency spectra of the basis functions of said intermediate transform resemble the frequency spectra of said first and second transform.

6. A storage medium on which an encoded signal as claimed in claim 5 has been stored.

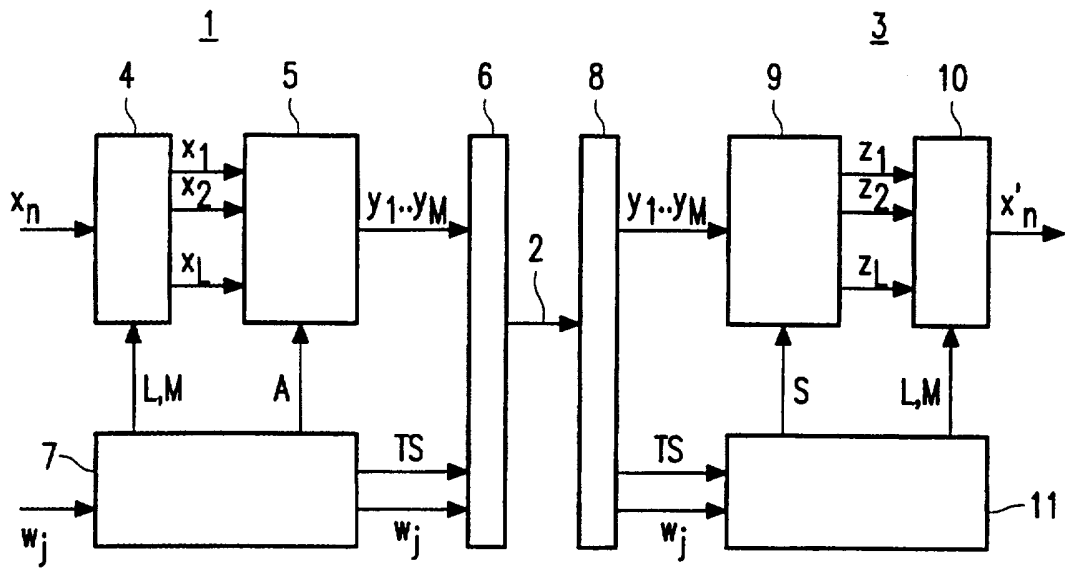

FIG. 1

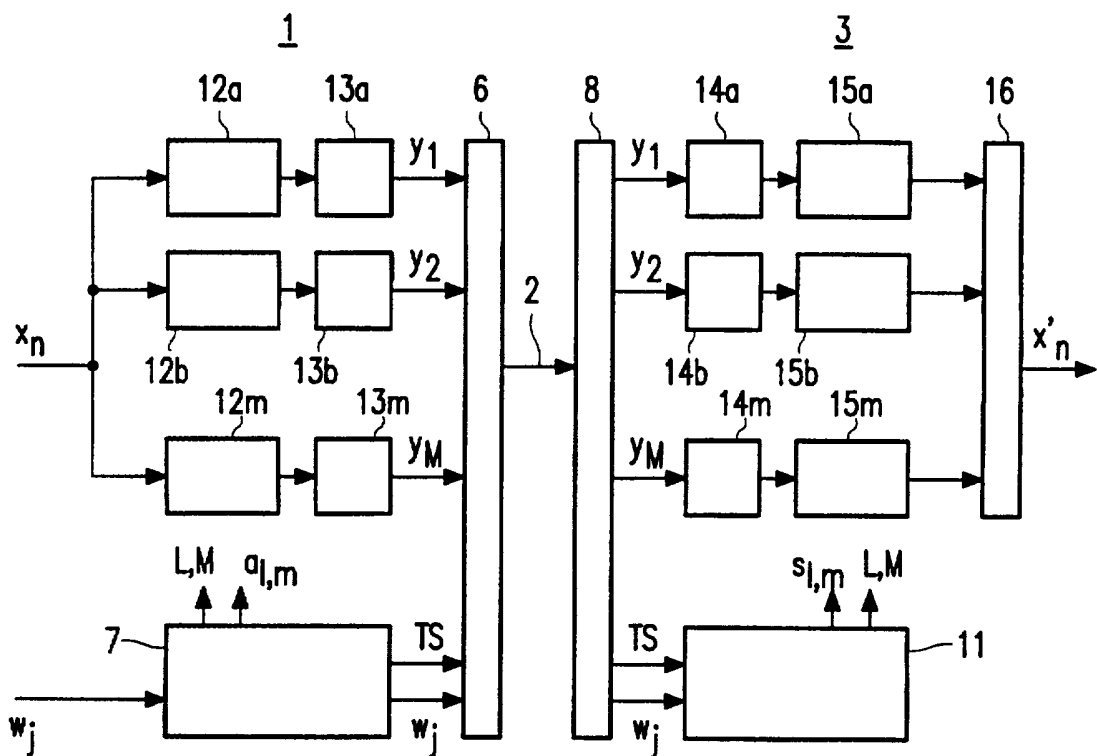

FIG. 2

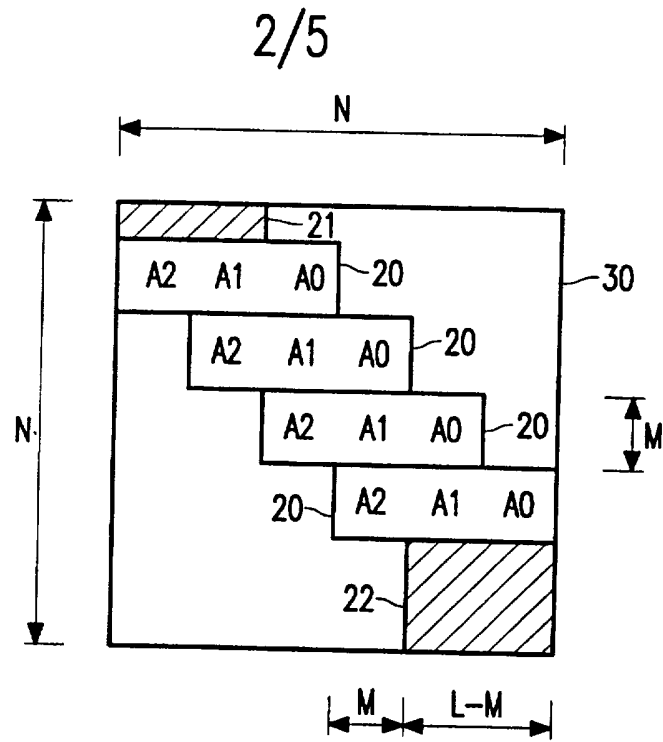

FIG. 3

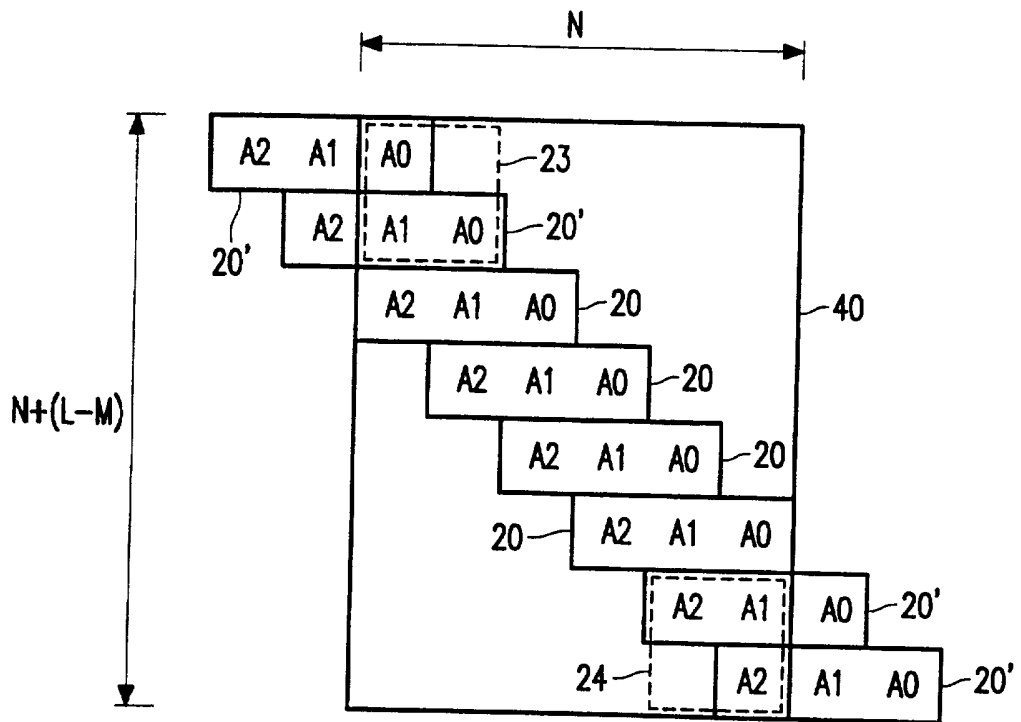

FIG. 4

3/5

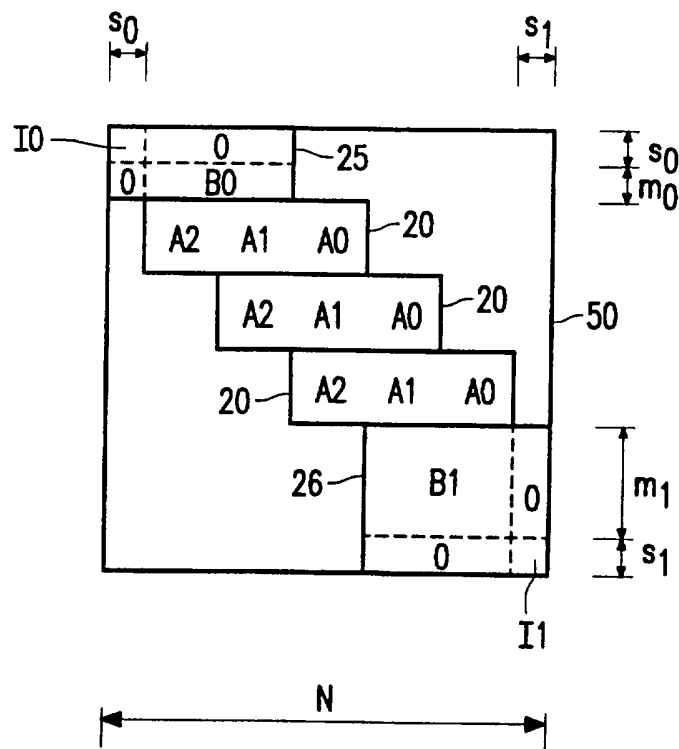

FIG. 5

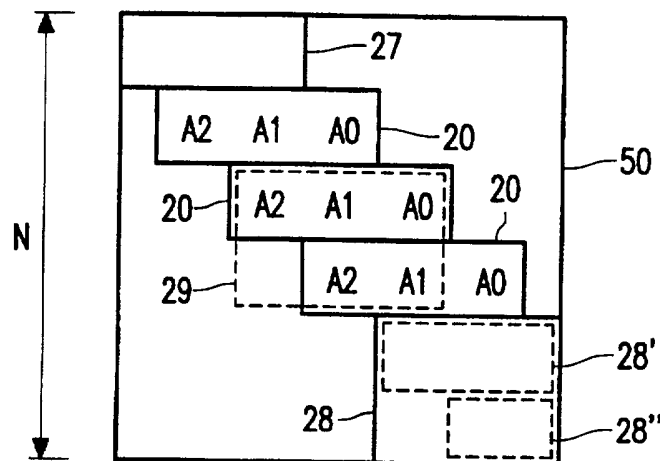

FIG. 6

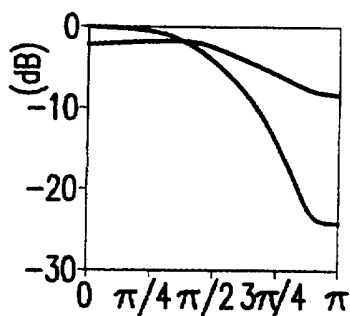

FIG. 7A

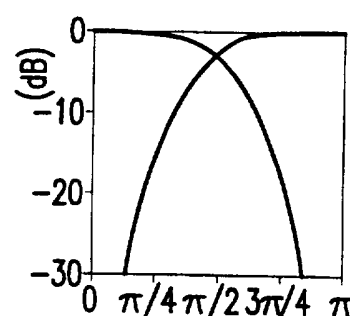

FIG. 7B

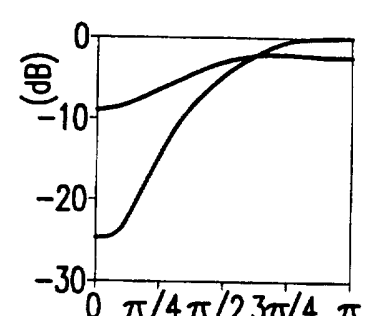

FIG. 7C

4/5

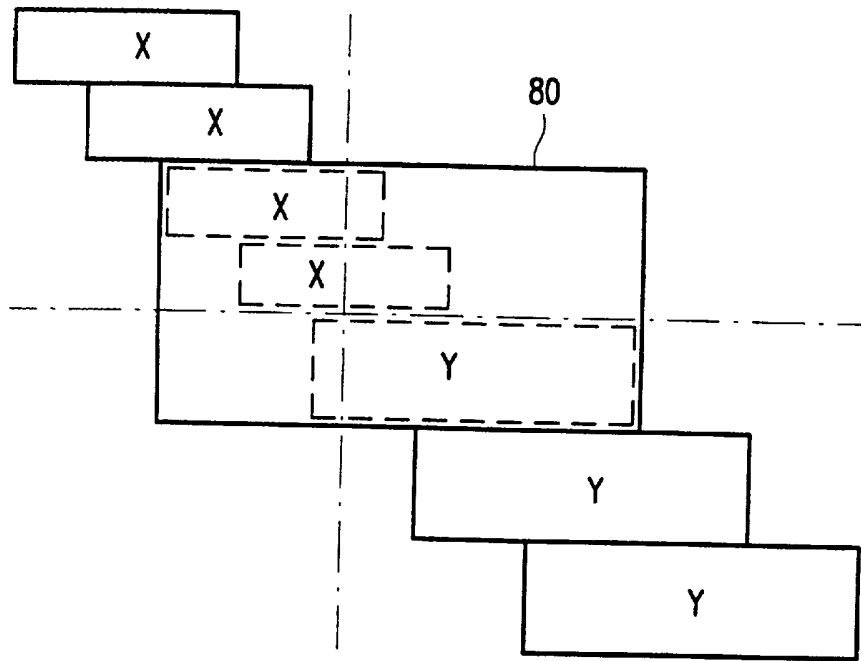

FIG. 8

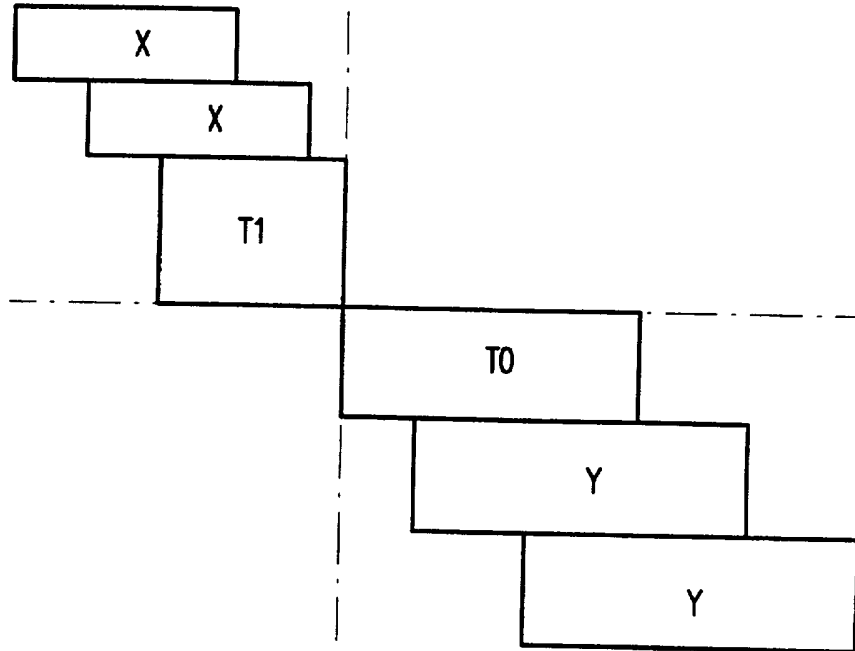

FIG. 9

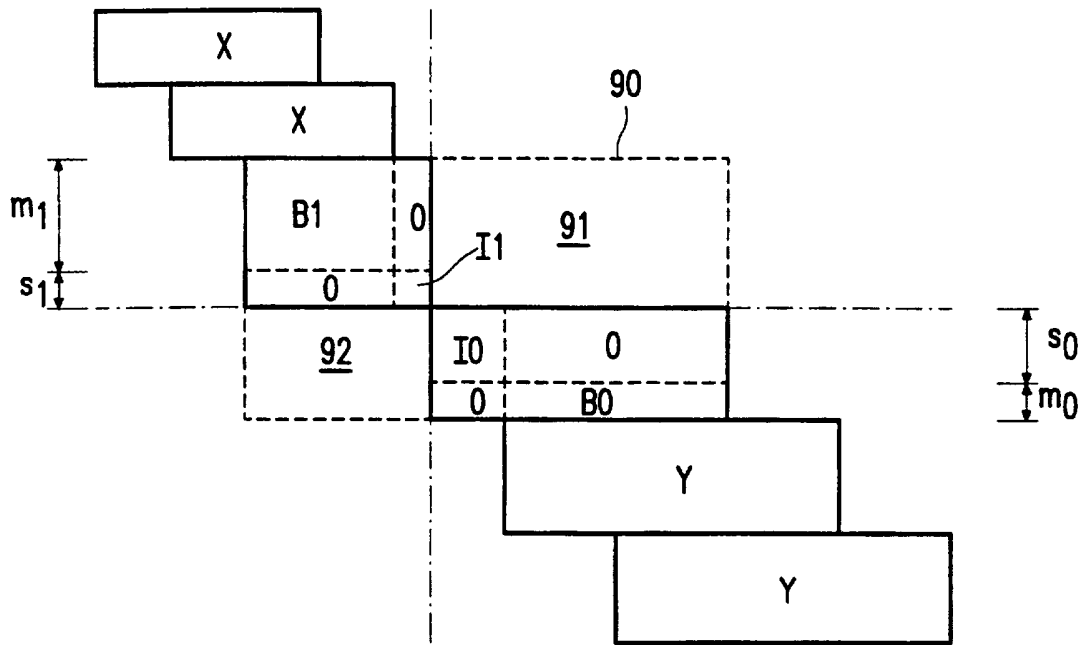

FIG. 10

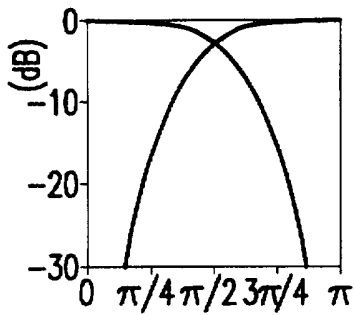

FIG. 11A

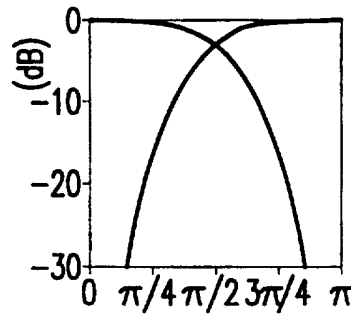

FIG. 11B

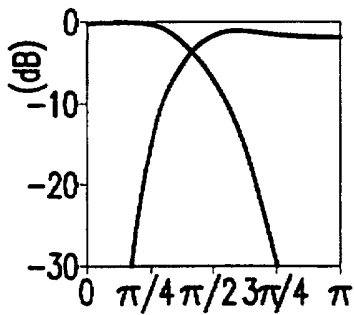

FIG. 11C

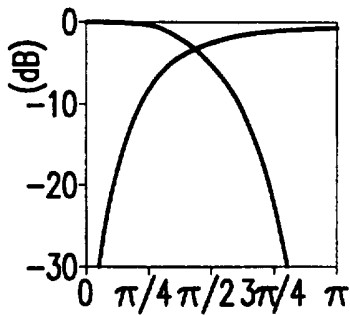

FIG. 11D

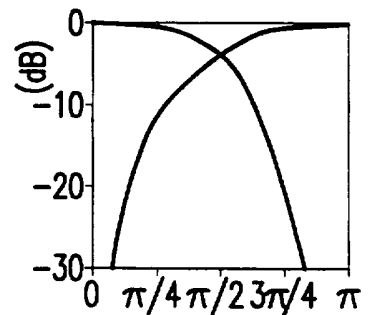

FIG. 11E