

E. J. RYAN.
SASH FASTENER.

(Application filed Mar. 5, 1901.)

(No Model.)

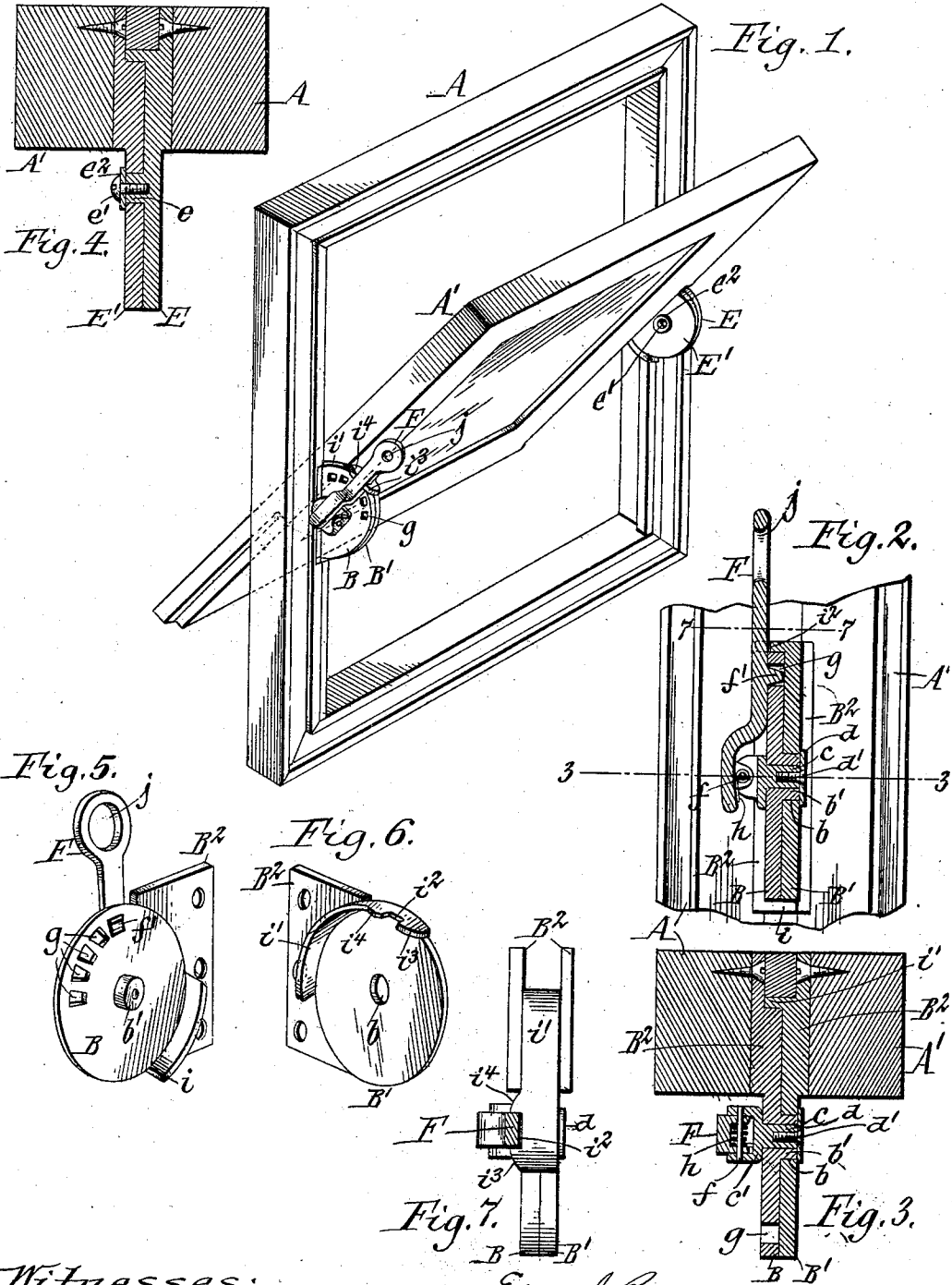

Witnesses:
F. F. Schuyler
Henry L. Deck.

Edward J. Ryan. Inventor.
By Wilhelm Hornier. Attorneys.

UNITED STATES PATENT OFFICE.

EDWARD J. RYAN, OF BUFFALO, NEW YORK.

SASH-FASTENER.

SPECIFICATION forming part of Letters Patent No. 676,155, dated June 11, 1901.

Application filed March 5, 1901. Serial No. 49,776. (No model.)

To all whom it may concern:

Be it known that I, EDWARD J. RYAN, a citizen of the United States, residing at Buffalo, in the county of Erie and State of New York, have invented new and useful Improvements in Sash-Fasteners, of which the following is a specification.

This invention relates to the fasteners which are employed for holding a pivoted sash or transom in a more or less open position or locking it in its closed position.

One of the objects of my invention is to provide an inexpensive fastener of simple construction which positively locks the sash in any desired position and which can be conveniently manipulated.

A further object is to so construct the fastener that before swinging the sash or transom on its pivots the fastener can be set to automatically lock the sash in a predetermined position.

In the accompanying drawings, Figure 1 is a perspective view of a window equipped with my improvement. Fig. 2 is a vertical section of the fastener, taken lengthwise through the locking-catch in the closed position of the sash. Fig. 3 is a horizontal section of the fastener and the adjacent sash-pivot in line 3 3, Fig. 2. Fig. 4 is a similar section of the pivot on the opposite side of the sash. Figs. 5 and 6 are detached perspective views of the pivot-plates with which the locking-catch cooperates. Fig. 7 is a detached horizontal section in line 7 7, Fig. 2.

Like letters of reference refer to like parts in the several figures.

A is the window-frame, and A' the sash, pivoted centrally or between its ends to the frame by suitable horizontal pivots, so that the sash can be swung to a more or less open position. The pivotal joints with which my improved locking device is combined preferably consist of a pair of vertical circular plates or disks B B', having integral wings B², whereby they are secured to the vertical edge of the sash and the opposing face of the window-frame, respectively. The inner plate B' is provided with a central opening b, which receives a hollow pintle b', arranged on the fixed plate B, as shown in Figs. 2 and 3. The plates are held in place by a pivot-pin c, arranged in the hollow pintle b and having a

head c', which bears against the outer side of the fixed plate B, and a washer d, bearing against the inner side of the sash-plate B' and secured to said pivot-pin by a screw d'. The pivot on the opposite side of the sash preferably consists of two plates E E', similar to the plates B B', one of which has a solid pintle e, which enters an opening in the other, as shown in Fig. 4. The plates E E' are held together by a screw e' and washer e².

F is an adjustable locking catch or stop which cooperates with one of the pivots, preferably the left-hand pivot-plates B B', for holding the sash at any desired inclination. This catch preferably consists of a spring-pressed lever arranged radially on the outer side of the fixed plate B and pivoted by a transverse pin f to the bifurcated head of the pivot-pin c, so as to be capable of a combined lateral and oscillating movement relatively to said plate. This catch-lever is provided on its inner side with a lug or projection f', which is adapted to interlock with one of a segmental series of locking-faces arranged on the fixed plate B, concentrically with the pivot-pin c. These locking-faces are preferably formed by openings or recesses g in said plate, as shown.

h is a spring which tends to hold the locking-lever in engagement with the fixed plate B and which is preferably coiled around the fulcrum-pin f of the lever and bears at one end against the lever and at its other end against the oscillating pivot-pin c.

The fixed pivot-plate B is provided with an inwardly-extending marginal flange i, which overlaps and bears against the edge of the movable plate B', and the latter is provided with a similar flange i', which in turn bears against the edge of the fixed plate. These flanges are arranged at opposite edges of the plates in the closed position of the sash and serve to prevent dust accumulating between the plates and also relieve the pintle b' from strain. The flange i' of the sash-plate B' is provided in its outer edge with a locking-notch i², which is adapted to receive the locking-lever F, as shown in Figs. 1, 2, and 7, so as to lock the sash to the lever. The portion of the flange i' which contains the locking-notch i² projects beyond the remaining portion of the flange and is provided on

opposite sides of the notch with inclined faces i^3 i^4 , which allow the locking-lever to engage automatically with said notch upon swinging the sash in either direction. The locking-lever may be provided in its free end with an opening j for receiving the hooked end of a rod, by which the lever may be unlocked when the same cannot be conveniently manipulated from the floor.

10 When the sash or transom is in its closed position, it is locked by the engagement of the locking-lever F with the uppermost opening g of the fixed plate B , and the engagement of the lever with the locking-notch i^2 15 of the oscillating sash-plate B' , as shown in Fig. 2. When it is desired to open the sash, the locking-lever is swung outwardly sufficiently to withdraw its lug f' from the opening of the fixed plate B and the notch i^2 , and 20 the lever is then turned to about the angle at which it is desired to place the sash and released to allow its lug f' to interlock with the opposing opening of the plate B . The lever being now set and locked the sash is turned 25 until the notch i^2 of the sash-plate B' meets the locking-lever, when the latter automatically interlocks with said notch, as shown in Fig. 1. As the lever is now interlocked with the fixed plate and the sash is interlocked 30 with the lever, the sash is positively held in the desired position. To release the sash, the locking-lever is swung out of engagement with the fixed plate B and the notch i^2 , whereupon the sash can be turned or closed 35 to a different angle.

The lug f' of the locking-lever is longer than the height of the inclines i^3 i^4 on opposite sides of the notch i^2 , so that upon swinging the sash on its pivot the advancing incline in tripping 40 over the lever will not deflect the same sufficiently to wholly withdraw its lug from the opening of the fixed plate B , thereby preventing displacement of the lever by said inclines.

By constructing the fastener so that the 45 locking devices can be set to lock the sash in a predetermined position before swinging the sash the locking device and the sash need not be manipulated at the same time, but may be handled separately and with one hand, if desired. This is an important advantage in the 50 case of a large and heavy sash.

I claim as my invention—

1. The combination with a window-frame, and a pivoted sash provided at one edge with 55 a locking device, of a plate secured to the

window-frame adjacent to said locking device and provided with a series of locking-faces, a locking-lever mounted on said plate and capable of a combined lateral and oscillating movement with reference thereto and arranged to interlock with one of said locking-faces and the locking device of the sash, substantially as set forth. 60

2. The combination with a window-frame and a pivoted sash provided at one edge with a laterally-projecting flange having a locking-notch, of a plate secured to the window-frame adjacent to said notched flange and provided with a series of locking-recesses, an oscillating pivot-pin journaled in said plate, and a 70 locking-lever fulcrumed on said pivot-pin and arranged to interlock with said notched flange and provided with a lug which is arranged to interlock with the recesses of said plate, substantially as set forth. 75

3. The combination with a window-frame and a pivoted sash provided at one edge with a laterally-projecting flange having a locking-notch, of a plate secured to the window-frame adjacent to said notched flange and provided 80 with a series of locking-recesses, an oscillating pivot-pin journaled in said plate, a locking-lever fulcrumed on said pivot-pin and arranged to interlock with said notched flange and provided with a lug which is arranged to 85 interlock with the recesses of said plate, and a spring arranged to hold said lever in engagement with said notched flange, substantially as set forth.

4. The combination with a window-frame 90 and a pivoted sash, of pivot plates or disks secured to the edge of the sash and the opposing face of the window-frame respectively, and each provided with a marginal flange which overlaps the edge of the plate, the 95 flange of the sash-plate being provided with a locking-notch, and the other fixed plate being provided with a segmental series of locking-recesses, an oscillating pivot-pin journaled in said plates, and a radial locking-lever 100 fulcrumed on said pivot-pin and arranged to interlock with said locking-notch and provided with a lug arranged to engage with said locking-recesses, substantially as set forth.

Witness my hand this 28th day of February, 1901. 105

EDWARD J. RYAN.

Witnesses:

JNO. J. BONNER,
CLAUDIA M. BENTLEY.