

(19)  
(12)

(KR)  
(A)

(51) 。 Int. Cl. <sup>7</sup>  
E01F 15/00

(11)  
(43)

2002 - 0043473  
2002 06 10

(21) 10 - 2002 - 0021390  
(22) 2002 04 18

(71) 992 - 9 가 - 301

(72) 992 - 9 가301

:

(54)

가

가

가

(10)	(7)	(1)	(3)	(2)	(8)	(4)	(5)
(18.19.20)	(21)	(6)	(22.23.24)	(31)	(1 - 1)	가	(9)
27)	(22.23.24)	(14)	(5)	(28)	(15.16.17)	(15.16.17)	(15.16.17)
(32)	(33)	(29)	(30)	(5)	(5)	가	(25.26.
(12)							(11)

상세도  
상세도 1.2  
조립도  
조립도 1.2.3

1.2

1

2

3

[ ]

1: 1 - 1:

2: 3:

4: 5:

6: 7:

8: 9:

10: 11:

12: 13:

14: 15.16.17:

18.19.20: 21:

22.23.24: 25.26.27:

28: 29:

30: 31:

32: 33:



21)

가

(2)	(4)	(1)	(3)	(5)	(7)
(6)		(8)		(9)	(10)
		(1-1)		(1)	(13)
(14)			가	(15.16.17)	(18.19.20)
	(22.23.24)		(15.16.17)	(25.26.27)	(22.23.24)
		(31)	(28)		(32)
	(5)		(5)		(33)
	(29)	(30)			(11)
					(12)

(28)

(15.16.17)가

가

(25.26.27)가 가  
(21)

(5)

(15.16.17)

(6)

(25.26.27)가 가  
(21)

가

(5)

(15.16.17)

(6)

가

(15.16.17)  
(6)

(25.26.27)가 가  
(21)

(5)

(5)	(12)	(30)	(29)	가	(11)	(15.16.17)
(5)	(15.16.17)가	(32)			(28)	(5)
(11)	(12)	(29)	(30)	(28)	(15.16.17)	(33)
					(5)	

5.26.27)가 가 (21) (5) (15.16.17) (6) 가 (2)  
 (11) 가

(25.26.27)  
 (57)

1.

(7)	(1)	(3)	(2)	(8)	(4)	(5)	(10)
	(6)			(1 - 1)		(9)	
(13)	(14)					(1)	(18.
19.20)	(21)	(22.23.24)		가	(15.16.17)	(25.26.27)	(32)
(22.23.24)		(31)		(15.16.17)	(5)		(11)
(33)	(5)	(28)					
(12)	(29)	(30)					

1  
상세도

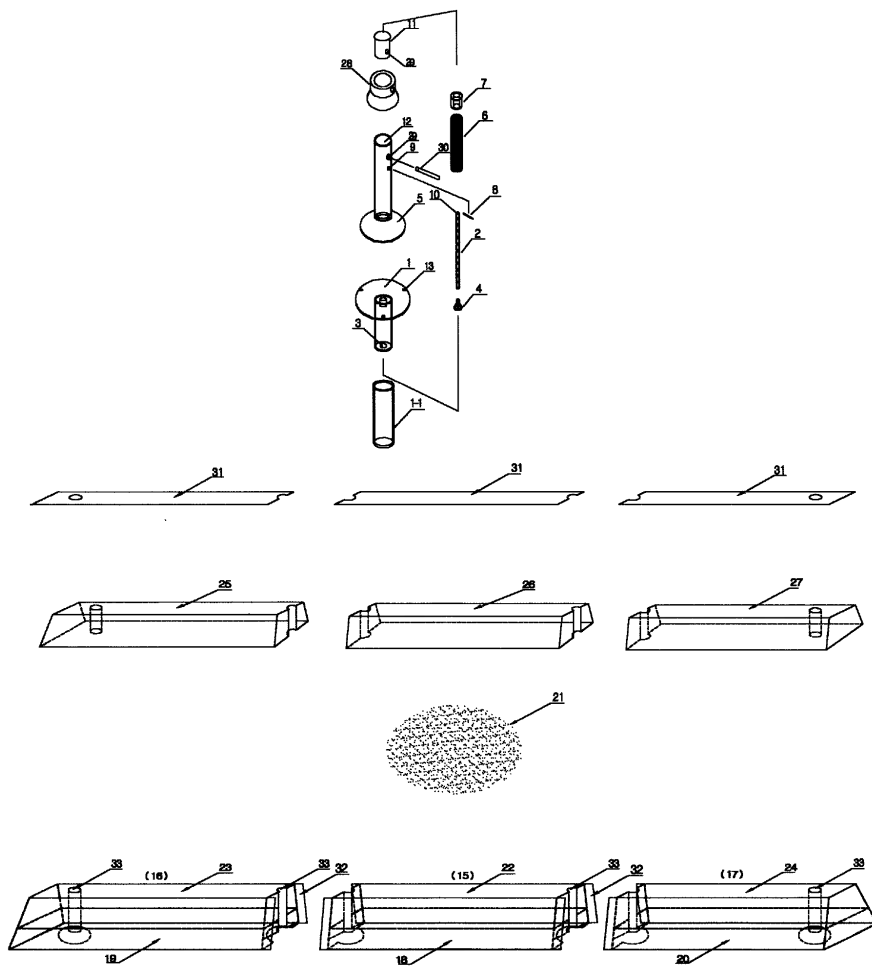

2

상세도-1

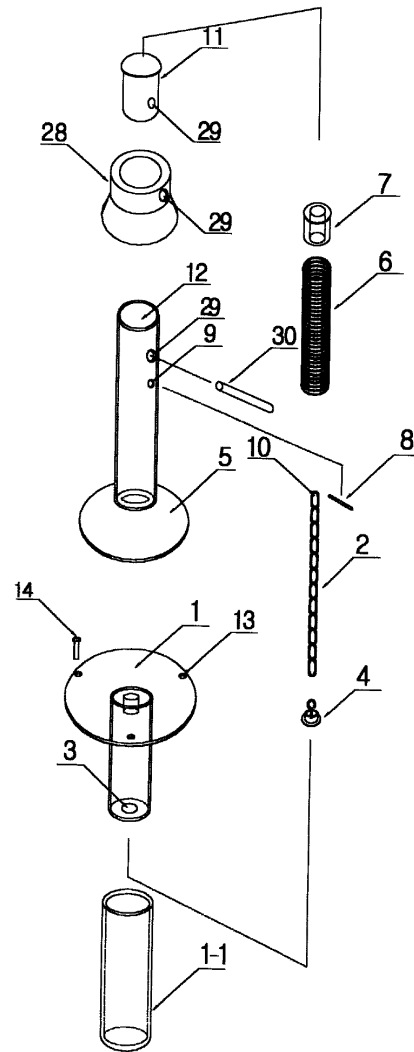

3

상세도-2

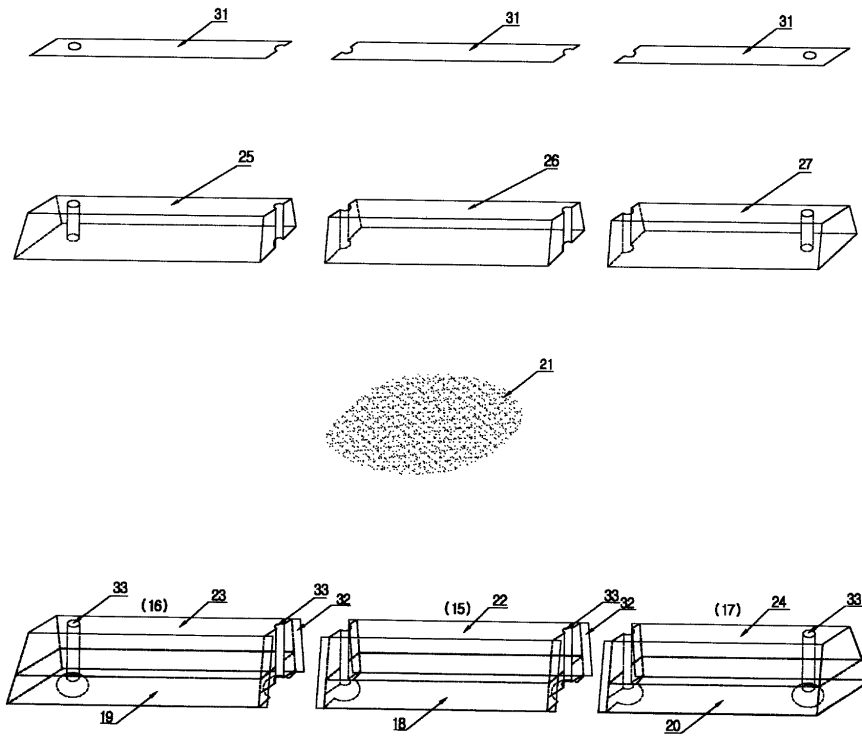

4

조립도

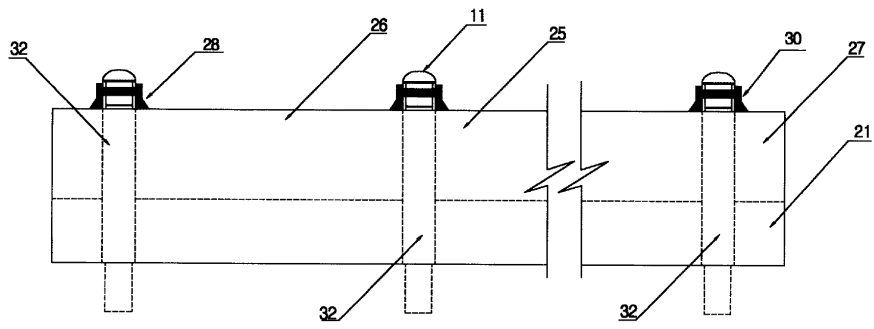

5

조립도-1

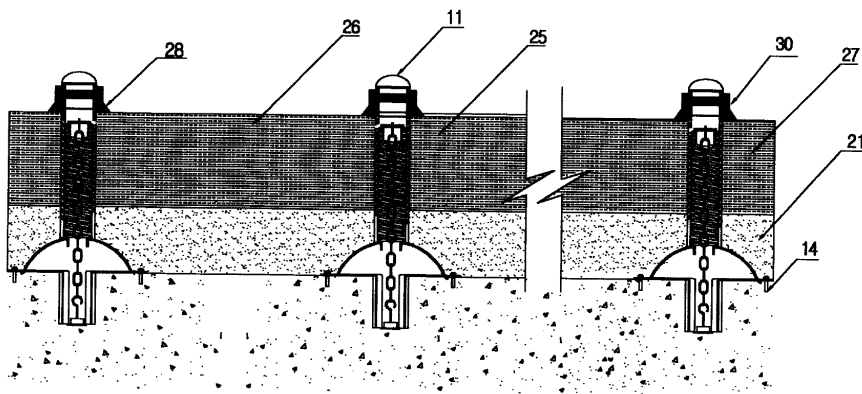

6

조립도-2

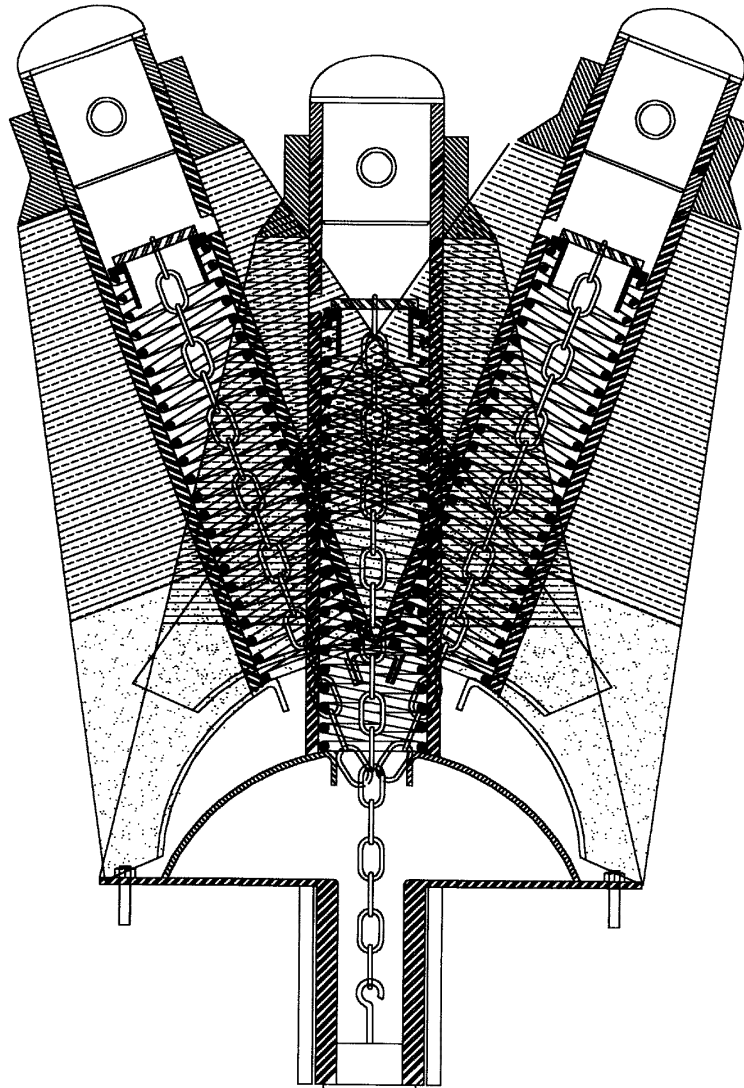

7

조립도-3

