



(12) **EUROPEAN PATENT APPLICATION**

(88) Date of publication A3:
02.08.2006 Bulletin 2006/31

(51) Int Cl.:
H01L 41/083^(2006.01) F02M 51/06^(2006.01)

(43) Date of publication A2:
05.12.2001 Bulletin 2001/49

(21) Application number: **01113169.5**

(22) Date of filing: **30.05.2001**

(84) Designated Contracting States:
**AT BE CH CY DE DK ES FI FR GB GR IE IT LI LU
MC NL PT SE TR**
Designated Extension States:
AL LT LV MK RO SI

(30) Priority: **31.05.2000 JP 2000163233
31.05.2000 JP 2000163235
26.04.2001 JP 2001130167
26.04.2001 JP 2001130169**

(71) Applicant: **DENSO CORPORATION
Kariya-city,
Aichi-pref. 448-8661 (JP)**

(72) Inventors:
• **Kobayashi, Masayuki
Kariya-city,
Aichi-pref. 448-8661 (JP)**
• **Mitarai, Shinya
Kariya-city,
Aichi-pref. 448-8661 (JP)**
• **Yamamoto, Takashi
Kariya-city,
Aichi-pref. 448-8661 (JP)**
• **Hattori, Hidekazu
Kariya-city,
Aichi-pref. 448-8661 (JP)**

(74) Representative: **TBK-Patent
Bavariaring 4-6
80336 München (DE)**

(54) **Piezoelectric device for injector**

(57) A piezoelectric device 1 for an injector, built into an injector and generating driving force of the injector, wherein a relation $d(0.1E_c)/d(1.2E_c) \geq 0.50$ is established between an apparent piezoelectric constant $d(1.2E_c)$ calculated from static elongation when an electric field of 1.2 Ec is applied to the piezoelectric device in the same direction as a polarizing direction while a preset load of 500 N is applied to the piezoelectric device, and an apparent piezoelectric constant $d(0.1E_c)$ calculated from static elongation when an electric field of 0.1 Ec is applied to the piezoelectric device in the same direction as the polarizing direction. The piezoelectric device so fabricated has high durability and can be used for a long time. The piezoelectric device 1 is fabricated by alternately laminating a plurality of piezoelectric layers expanding and contracting in proportion to an applied voltage and a plurality of internal electrode layers for supplying the applied voltage, and the sectional shape of the piezoelectric device crossing at right angles the laminating direction is partially or wholly arcuate. The piezoelectric device 1 is accommodated in a cylindrical accommodation space.

Fig.14

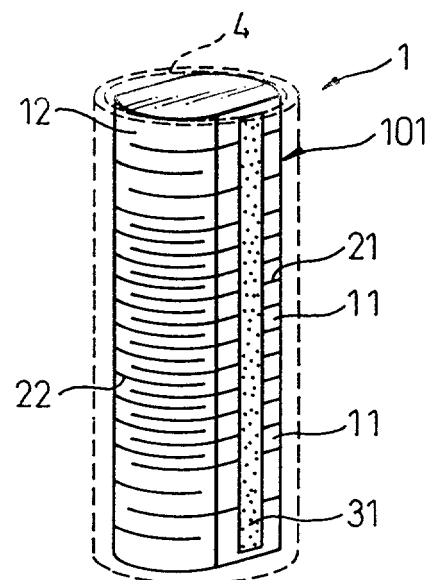



DOCUMENTS CONSIDERED TO BE RELEVANT

Category	Citation of document with indication, where appropriate, of relevant passages	Relevant to claim	CLASSIFICATION OF THE APPLICATION (IPC)
Y	GB 2 094 940 A (NISSAN MOTOR CO LTD) 22 September 1982 (1982-09-22) * page 2, line 7 - line 16; figures 1,4 * * page 2, line 117 - page 3, line 105 * -----	1,2	INV. H01L41/083 F02M51/06
Y	US 4 803 393 A (TAKAHASHI ET AL) 7 February 1989 (1989-02-07)	1,2	
Y	* column 5, line 1 - line 8; figures 1,2 * * column 3, line 36 - line 39 *	3,4	
Y	-----	7,8	
Y	EP 0 371 469 A (TOYOTA JIDOSHA KABUSHIKI KAISHA) 6 June 1990 (1990-06-06) * column 6, line 45 - column 7, line 15 * * column 7, line 47 - column 12, line 14 * -----	1,2	
Y	MITROVIC M ET AL: "Electro-mechanical characterization of piezoelectric stack actuators" PROCEEDINGS OF THE SPIE - THE INTERNATIONAL SOCIETY FOR OPTICAL ENGINEERING SPIE-INT. SOC. OPT. ENG USA, vol. 3668, March 1999 (1999-03), pages 586-601, XP002318467 ISSN: 0277-786X	1,2	TECHNICAL FIELDS SEARCHED (IPC)
Y	* figures 4,5; table 1 * -----	7,8	H01L F02M
A	DE 196 15 695 C1 (SIEMENS AG, 80333 MUENCHEN, DE) 3 July 1997 (1997-07-03) * column 3, lines 15-33 * -----	1,2	
A	DE 26 19 704 B1 (SIEMENS AG) 5 May 1977 (1977-05-05) * column 2, line 12 - line 19 * -----	1,2	
A	EP 0 780 350 A (MURATA MANUFACTURING CO., LTD) 25 June 1997 (1997-06-25) * page 5, line 41 - line 44 * -----	1,2	
	-/--		
6 The present search report has been drawn up for all claims			
Place of search Munich		Date of completion of the search 13 June 2006	Examiner Gröger, A
CATEGORY OF CITED DOCUMENTS			
X : particularly relevant if taken alone Y : particularly relevant if combined with another document of the same category A : technological background O : non-written disclosure P : intermediate document		T : theory or principle underlying the invention E : earlier patent document, but published on, or after the filing date D : document cited in the application L : document cited for other reasons & : member of the same patent family, corresponding document	



DOCUMENTS CONSIDERED TO BE RELEVANT				
Category	Citation of document with indication, where appropriate, of relevant passages	Relevant to claim	CLASSIFICATION OF THE APPLICATION (IPC)	
A	HUAXIANG FU ET AL: "Polarization rotation mechanism for ultrahigh electromechanical response in single-crystal piezoelectrics" NATURE MACMILLAN MAGAZINES UK, vol. 403, no. 6767, 20 January 2000 (2000-01-20), pages 281-283, XP002318468 ISSN: 0028-0836 * the whole document *	1,2		
Y	E. WEHRSDORFER, G. BORCHHARDT, W. KARTHE, G. HELKE: "Large Signal Measurements on Piezoelectric Stacks" Ferroelectrics Gordon & Breach Switzerland, vol. 174, no. 3-4, 1995, pages 259-275, XP009054824 ISSN: 0015-0193 * figures 5,8 *	3,4		
Y	* figures 5,8 *	5,6		
Y	MICHAEL GOLDFARB, NIKOLA CELANOVIC: "Modeling Piezoelectric Stack Actuators for Control of Micromanipulation" IEEE Control Systems Magazine IEEE USA, vol. 17, no. 3, June 1997 (1997-06), pages 69-79, XP002348515 ISSN: 0272-1708 * figure 3 *	3,4		TECHNICAL FIELDS SEARCHED (IPC)
Y	* figure 3 *	7,8		
Y	TAKESHI NISHIZAWA, MITSUNORI SANO, SATORU TAGAMI: "Multilayer Piezoelectric Actuator" NEC Technical Journal Japan, vol. 40, no. 5, 1987, pages 118-122, XP009054834 ISSN: 0285-4139 * figure 6 *	3,4		
----- -/--				
The present search report has been drawn up for all claims				
Place of search Munich		Date of completion of the search 13 June 2006	Examiner Gröger, A	
CATEGORY OF CITED DOCUMENTS X : particularly relevant if taken alone Y : particularly relevant if combined with another document of the same category A : technological background O : non-written disclosure P : intermediate document		T : theory or principle underlying the invention E : earlier patent document, but published on, or after the filing date D : document cited in the application L : document cited for other reasons & : member of the same patent family, corresponding document		

6
EPC FORM 1503 03.02 (P04C01)



DOCUMENTS CONSIDERED TO BE RELEVANT			
Category	Citation of document with indication, where appropriate, of relevant passages	Relevant to claim	CLASSIFICATION OF THE APPLICATION (IPC)
Y	M. KONDO, K. OHYA, S. SHIMIZU: "Effects of One-Dimensional Compressive Stress on the Properties of Multilayer Piezoelectric Ceramic Actuator" 1990 IEEE 7TH INTERNATIONAL SYMPOSIUM ON APPLICATIONS OF FERROELECTRICS (CAT. NO. 90CH2800-1) 6-8 JUNE 1990 URBANA-CHAMPAIGN, IL, USA, 1991, pages 530-534, XP010053064 1990 IEEE 7th International Symposium on Applications of Ferroelectrics (Cat. No. 90CH2800-1) IEEE New York, NY, USA ISBN: 0-7803-0190-0 * figure 9 *	3,4	
Y	TAKESHI INOUE, SADAYUKI TAKAHASHI: "Measurements for Piezoelectric Ceramic Properties Applied Compressive Stress Parallel to the Polar Axis" Transactions of the Institute of Electronics and Communication Engineers of Japan, Section E (English) Japan, vol. E69, no. 11, 11 November 1986 (1986-11-11), pages 1180-1187, XP009055034 ISSN: 0387-236X * figures 8-11 *	3,4	TECHNICAL FIELDS SEARCHED (IPC)
X	US 5 092 360 A (WATANABE ET AL) 3 March 1992 (1992-03-03) * figures 1-3 *	5,6	
Y	* column 8, line 42 - line 48 *	5,6	
Y	* column 11, line 21 - line 34 *	9-19	
X		20-26	
Y		20-30	
	----- -/--		
The present search report has been drawn up for all claims			
Place of search Munich		Date of completion of the search 13 June 2006	Examiner Gröger, A
CATEGORY OF CITED DOCUMENTS X : particularly relevant if taken alone Y : particularly relevant if combined with another document of the same category A : technological background O : non-written disclosure P : intermediate document		T : theory or principle underlying the invention E : earlier patent document, but published on, or after the filing date D : document cited in the application L : document cited for other reasons & : member of the same patent family, corresponding document	

6
EPO FORM 1503 03.82 (P04C01)



DOCUMENTS CONSIDERED TO BE RELEVANT			
Category	Citation of document with indication, where appropriate, of relevant passages	Relevant to claim	CLASSIFICATION OF THE APPLICATION (IPC)
Y	KUNIHIRO NAGATA, EIKI HARASHIMA: "Improvement of Temperature Dependence of Piezoelectric Elements" 11TH MEETING ON FERROELECTRIC MATERIALS AND THEIR APPLICATIONS (FMA-11) 25-28 MAY 1994 KYOTO, JAPAN, vol. 33, no. 9B, September 1994 (1994-09), pages 5348-5351, XP002348517 Japanese Journal of Applied Physics, Part 1 (Regular Papers & Short Notes) Japan ISSN: 0021-4922 * figure 7 *	5,6	
Y	----- Q.M. ZHANG, H. WANG, N. KIM, L.E. CROSS: "Direct evaluation of domain-wall and intrinsic contributions to the dielectric and piezoelectric response and their temperature dependence on lead zirconate-titanate ceramics" 11TH MEETING ON FERROELECTRIC MATERIALS AND THEIR APPLICATIONS (FMA-11) 25-28 MAY 1994 KYOTO, JAPAN, vol. 75, no. 1, 1 January 1994 (1994-01-01), pages 454-459, XP002348518 Journal of Applied Physics ISSN: 0021-4922 * figures 1,5 * ----- -/--	5,6	
The present search report has been drawn up for all claims			TECHNICAL FIELDS SEARCHED (IPC)
6	Place of search Munich	Date of completion of the search 13 June 2006	Examiner Gröger, A
CATEGORY OF CITED DOCUMENTS X : particularly relevant if taken alone Y : particularly relevant if combined with another document of the same category A : technological background O : non-written disclosure P : intermediate document		T : theory or principle underlying the invention E : earlier patent document, but published on, or after the filing date D : document cited in the application L : document cited for other reasons ----- & : member of the same patent family, corresponding document	

EPO FORM 1503 03.82 (P/4C01)



DOCUMENTS CONSIDERED TO BE RELEVANT			
Category	Citation of document with indication, where appropriate, of relevant passages	Relevant to claim	CLASSIFICATION OF THE APPLICATION (IPC)
Y	ATUSHI OCHI, SADAYUKI TAKAHASHI, SATURO TAGAMI: "Temperature Characteristics for Multilayer Piezoelectric Ceramic Actuator" PROCEEDINGS OF THE 5TH MEETING ON FERROELECTRIC MATERIALS AND THEIR APPLICATIONS (FMA-5) 29-31 MAY 1985 KYOTO, JAPAN, vol. 24, 1985, pages 209-212, XP009054858 Japanese Journal of Applied Physics, Supplement Japan ISSN: 0021-4922 * figures 5,7 *	5,6	
Y	----- ZHANG X L ET AL: "Dielectric and piezoelectric properties of modified lead titanate zirconate ceramics from 4.2 to 300K" JOURNAL OF MATERIALS SCIENCE UK, vol. 18, no. 4, April 1983 (1983-04), pages 968-972, XP009055023 ISSN: 0022-2461 * figures 9,10 *	7,8	
Y	----- PAN MING-JEN ET AL: "Electroactive actuator materials: Investigations on stress and temperature characteristics" 1998, PROC SPIE INT SOC OPT ENG; PROCEEDINGS OF SPIE - THE INTERNATIONAL SOCIETY FOR OPTICAL ENGINEERING 1998, VOL. 3324, PAGE(S) 145 - 153 , XP002348924 * figures 5(a),5(d) * ----- -/--	5,6	
			TECHNICAL FIELDS SEARCHED (IPC)
The present search report has been drawn up for all claims			
6	Place of search Munich	Date of completion of the search 13 June 2006	Examiner Gröger, A
CATEGORY OF CITED DOCUMENTS X : particularly relevant if taken alone Y : particularly relevant if combined with another document of the same category A : technological background O : non-written disclosure P : intermediate document		T : theory or principle underlying the invention E : earlier patent document, but published on, or after the filing date D : document cited in the application L : document cited for other reasons ----- & : member of the same patent family, corresponding document	

EPO FORM 1503 03.82 (P04C01)



DOCUMENTS CONSIDERED TO BE RELEVANT

Category	Citation of document with indication, where appropriate, of relevant passages	Relevant to claim	CLASSIFICATION OF THE APPLICATION (IPC)
Y	PERTSCH P ET AL: "Characteristics of electromechanical solid state multilayer actuators" ISAF 1998. PROCEEDINGS OF THE ELEVENTH IEEE INTERNATIONAL SYMPOSIUM ON APPLICATIONS OF FERROELECTRICS (CAT. NO.98CH36245) IEEE PISCATAWAY, NJ, USA, 1998, pages 571-574, XP010347253 ISBN: 0-7803-4959-8 * figure 1 *	7,8	
A	ZHANG Q M ET AL: "Electromechanical properties of lead zirconate titanate piezoceramics under the influence of mechanical stresses" IEEE TRANSACTIONS ON ULTRASONICS, FERROELECTRICS AND FREQUENCY CONTROL IEEE USA, vol. 46, no. 6, November 1999 (1999-11), pages 1518-1526, XP002348520 ISSN: 0885-3010 * figures 1,2 *	7,8	TECHNICAL FIELDS SEARCHED (IPC)
A	KERSTEN O ET AL: "Dielectric dispersion in PZT ceramics" FERROELECTRICS UK, vol. 67, no. 2-4, March 1986 (1986-03), pages 191-197, XP009055022 ISSN: 0015-0193 * the whole document *	7,8	
Y	US 5 252 883 A (KONDO ET AL) 12 October 1993 (1993-10-12) * column 2, line 20 - line 63; figures 2,10 *	9-19	
Y		20-30	
The present search report has been drawn up for all claims			
Place of search Munich		Date of completion of the search 13 June 2006	Examiner Gröger, A
CATEGORY OF CITED DOCUMENTS X : particularly relevant if taken alone Y : particularly relevant if combined with another document of the same category A : technological background O : non-written disclosure P : intermediate document		T : theory or principle underlying the invention E : earlier patent document, but published on, or after the filing date D : document cited in the application L : document cited for other reasons & : member of the same patent family, corresponding document	



DOCUMENTS CONSIDERED TO BE RELEVANT			
Category	Citation of document with indication, where appropriate, of relevant passages	Relevant to claim	CLASSIFICATION OF THE APPLICATION (IPC)
Y	PATENT ABSTRACTS OF JAPAN vol. 016, no. 318 (E-1232), 13 July 1992 (1992-07-13) -& JP 04 091664 A (BROTHER IND LTD), 25 March 1992 (1992-03-25) * abstract; figure 1 *	9-19	
Y	PATENT ABSTRACTS OF JAPAN vol. 1995, no. 06, 31 July 1995 (1995-07-31) -& JP 07 079025 A (MURATA MFG CO LTD), 20 March 1995 (1995-03-20) * abstract; figures 1-3 *	16-19	
Y	US 4 803 763 A (ETURO ET AL) 14 February 1989 (1989-02-14) * column 1, line 31 - line 37; figures 3,4,6-10 *	20-26	
Y	PATENT ABSTRACTS OF JAPAN vol. 012, no. 277 (E-640), 30 July 1988 (1988-07-30) -& JP 63 055986 A (NEC CORP), 10 March 1988 (1988-03-10) * abstract; figures 1,8,9 *	20-26	TECHNICAL FIELDS SEARCHED (IPC)
Y	PATENT ABSTRACTS OF JAPAN vol. 012, no. 054 (E-583), 18 February 1988 (1988-02-18) -& JP 62 199076 A (FUJI ELELCTROCHEM CO LTD), 2 September 1987 (1987-09-02) * abstract; figure 1 *	20-26	
The present search report has been drawn up for all claims			
6	Place of search Munich	Date of completion of the search 13 June 2006	Examiner Gröger, A
CATEGORY OF CITED DOCUMENTS		T : theory or principle underlying the invention E : earlier patent document, but published on, or after the filing date D : document cited in the application L : document cited for other reasons & : member of the same patent family, corresponding document	
X : particularly relevant if taken alone Y : particularly relevant if combined with another document of the same category A : technological background O : non-written disclosure P : intermediate document			

ANNEX TO THE EUROPEAN SEARCH REPORT
ON EUROPEAN PATENT APPLICATION NO.

EP 01 11 3169

This annex lists the patent family members relating to the patent documents cited in the above-mentioned European search report. The members are as contained in the European Patent Office EDP file on
The European Patent Office is in no way liable for these particulars which are merely given for the purpose of information.

13-06-2006

Patent document cited in search report		Publication date	Patent family member(s)	Publication date
GB 2094940	A	22-09-1982	DE 3205654 A1 JP 57136859 U	07-10-1982 26-08-1982
US 4803393	A	07-02-1989	GB 2193386 A	03-02-1988
EP 0371469	A	06-06-1990	DE 68921047 D1 DE 68921047 T2 US 5057734 A	23-03-1995 14-06-1995 15-10-1991
DE 19615695	C1	03-07-1997	AT 186613 T CA 2252392 A1 CN 1217087 A WO 9740537 A1 EP 0894341 A1 ES 2140228 T3 IN 190409 A1 JP 2000508835 T KR 2000010523 A PT 894341 T RU 2169964 C2 US 6230378 B1	15-11-1999 30-10-1997 19-05-1999 30-10-1997 03-02-1999 16-02-2000 26-07-2003 11-07-2000 15-02-2000 28-04-2000 27-06-2001 15-05-2001
DE 2619704	B1	05-05-1977	NONE	
EP 0780350	A	25-06-1997	CN 1159435 A DE 69607119 D1 DE 69607119 T2 JP 3198906 B2 JP 9169566 A TW 400315 B US 5798052 A	17-09-1997 20-04-2000 10-08-2000 13-08-2001 30-06-1997 01-08-2000 25-08-1998
US 5092360	A	03-03-1992	DE 4036287 A1 GB 2239553 A	23-05-1991 03-07-1991
US 5252883	A	12-10-1993	JP 4340778 A	27-11-1992
JP 04091664	A	25-03-1992	NONE	
JP 07079025	A	20-03-1995	NONE	
US 4803763	A	14-02-1989	US 4845399 A	04-07-1989
JP 63055986	A	10-03-1988	NONE	
JP 62199076	A	02-09-1987	NONE	

EPO FORM P0459

For more details about this annex : see Official Journal of the European Patent Office, No. 12/82