



(19) **United States**

(12) **Patent Application Publication**
Farina

(10) **Pub. No.: US 2007/0175537 A1**

(43) **Pub. Date: Aug. 2, 2007**

(54) **APPARATUS AND METHOD FOR DISPENSING HIGH PURITY MATERIALS**

Publication Classification

(76) Inventor: **James Farina**, Nazareth, PA (US)

(51) **Int. Cl.**
B65B 31/00 (2006.01)

(52) **U.S. Cl.** **141/20**

Correspondence Address:
Christine Rebman Cooke
Mallinckrodt
675 McDonnell Boulevard
P O Box 5840
St Louis, MO 63134 (US)

(57) **ABSTRACT**

(21) Appl. No.: **10/594,485**

(22) PCT Filed: **Jun. 15, 2005**

(86) PCT No.: **PCT/US05/21234**

§ 371(c)(1),
(2), (4) Date: **Sep. 27, 2006**

This invention relates to a system or apparatus (10) and a method for dispensing a material (16) from a pressurized container (12) while maintaining product integrity. The system or apparatus comprises a pressurized container for holding the material and having a dispensing valve (20) provided with a dispensing conduit or stem (26) for dispensing the material from the container at the appropriate time, a syringe (42) equipped with an on/off locking mechanism (48) for permitting or preventing flow of the material into and out of the syringe by way of a stem or conduit (50) attached to the locking mechanism, and a removable adaptor (34) for connecting the stem of the syringe to the stem of the dispensing valve of the pressurized container for permitting flow of material from the pressurized container into a chamber of the syringe upon actuation of the dispensing valve.

Related U.S. Application Data

(60) Provisional application No. 60/585,663, filed on Jul. 6, 2004. Provisional application No. 60/621,030, filed on Oct. 21, 2004.

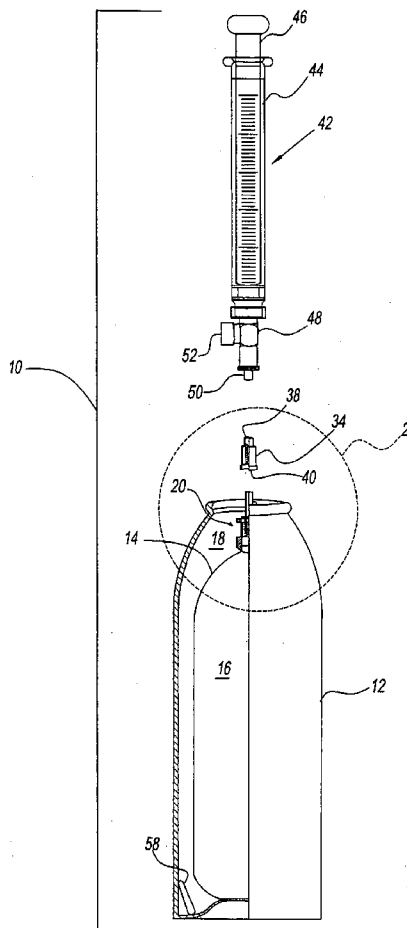

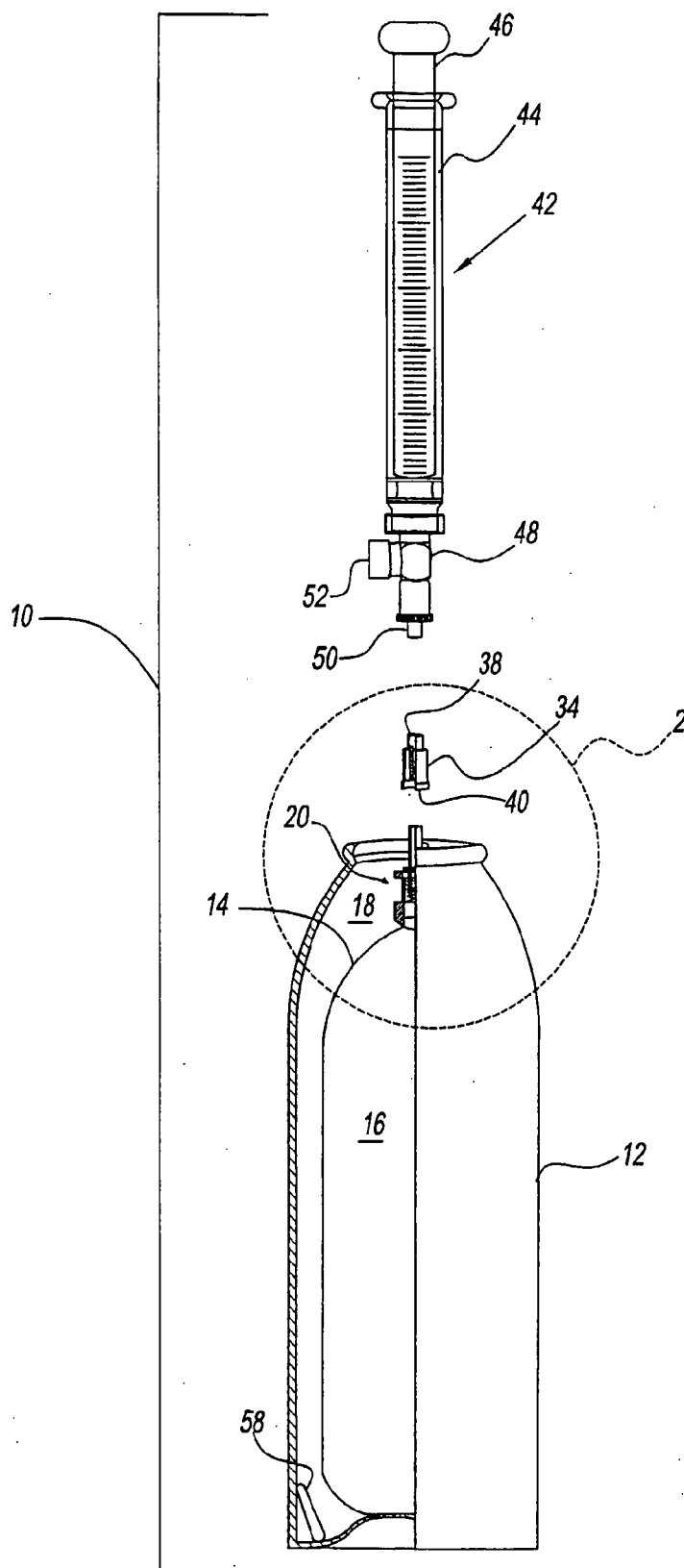

Fig. 1

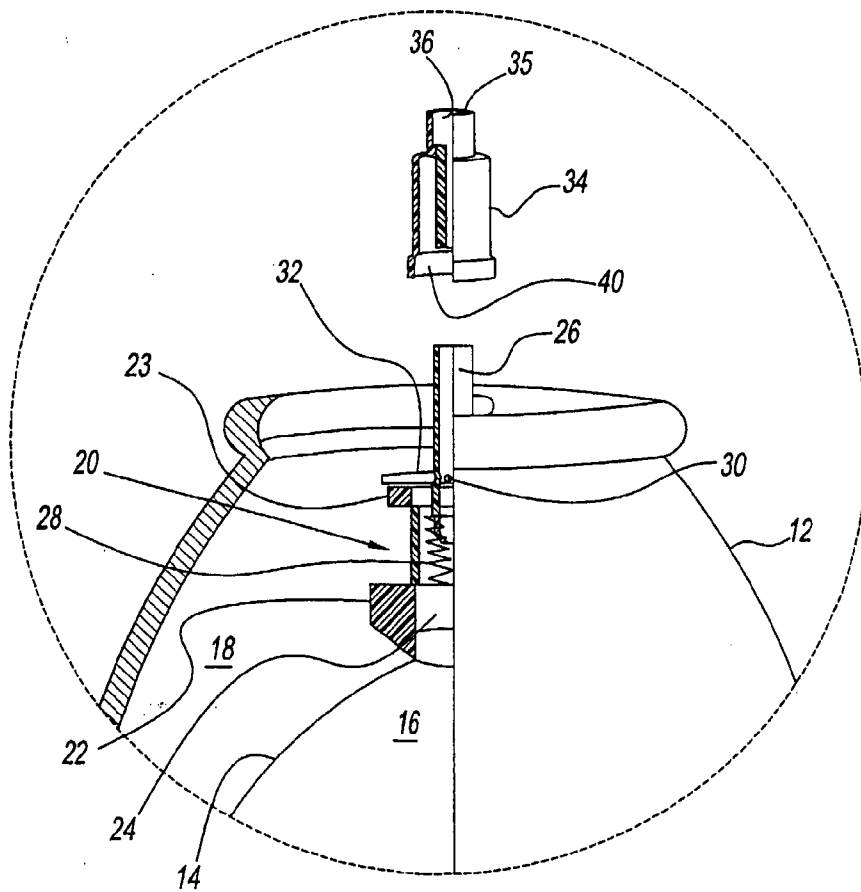
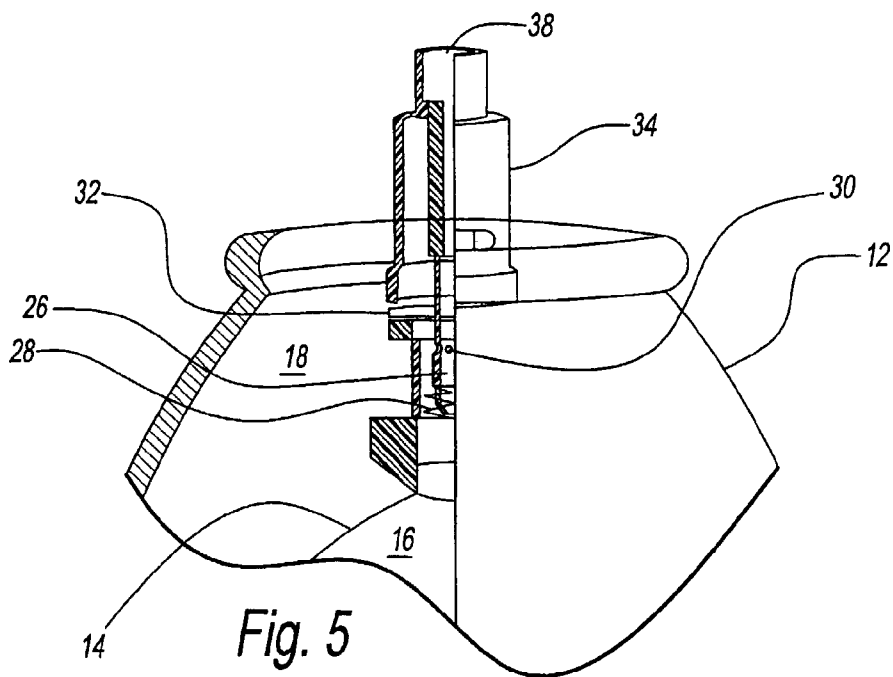

Fig. 2

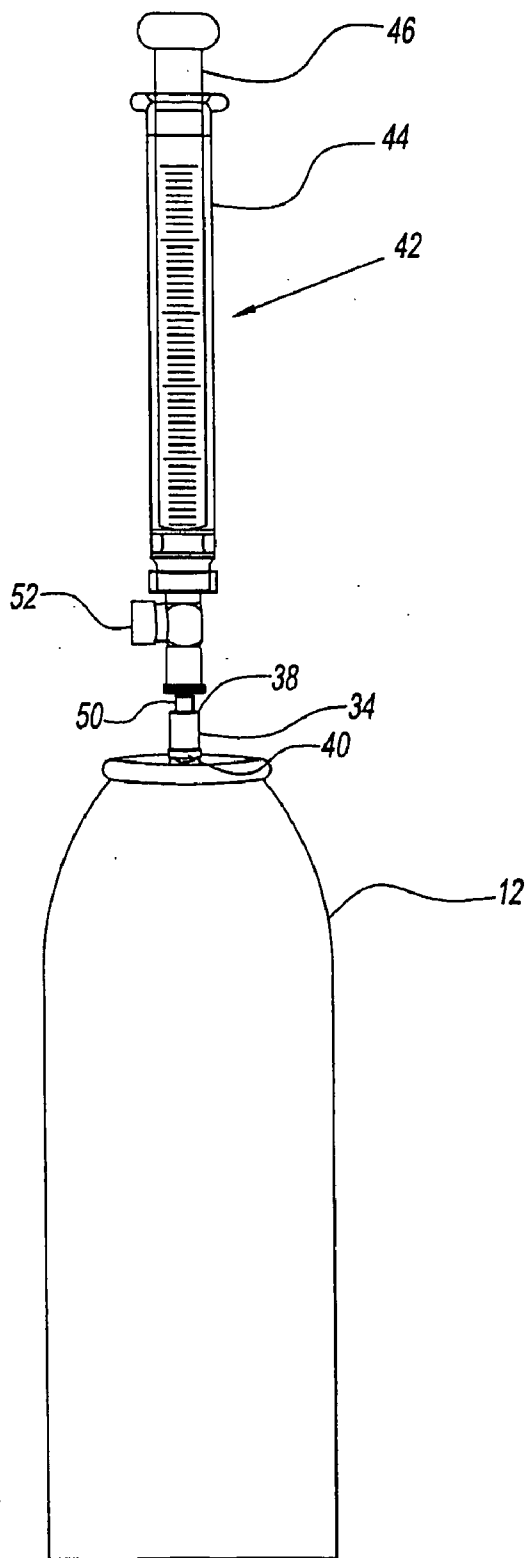

Fig. 3

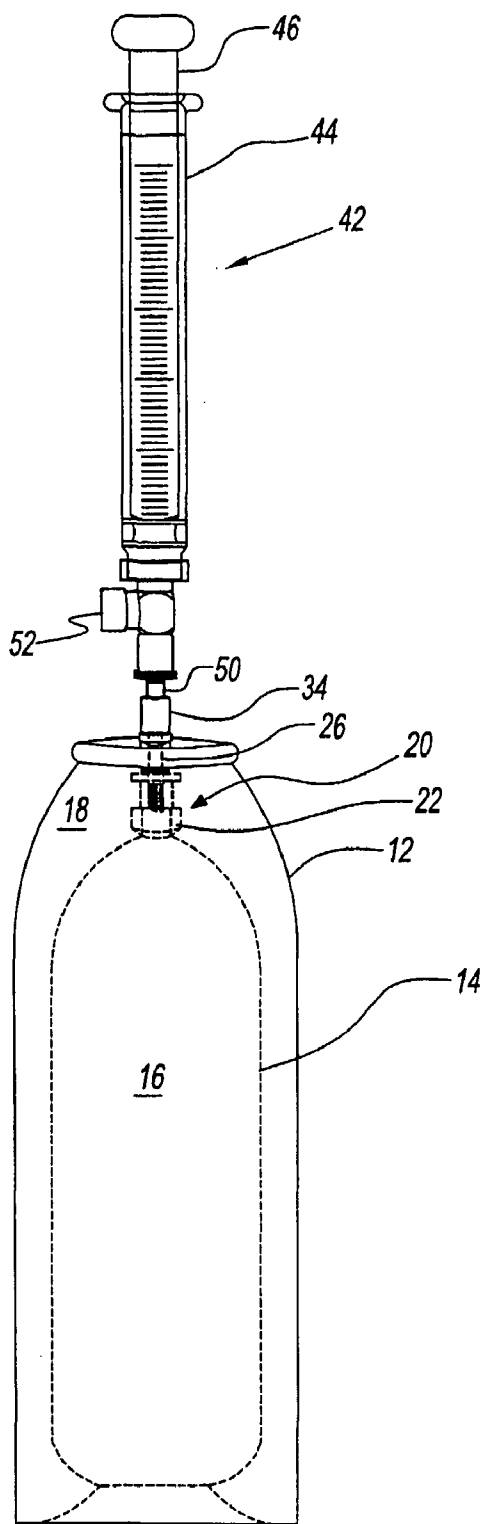

Fig. 4

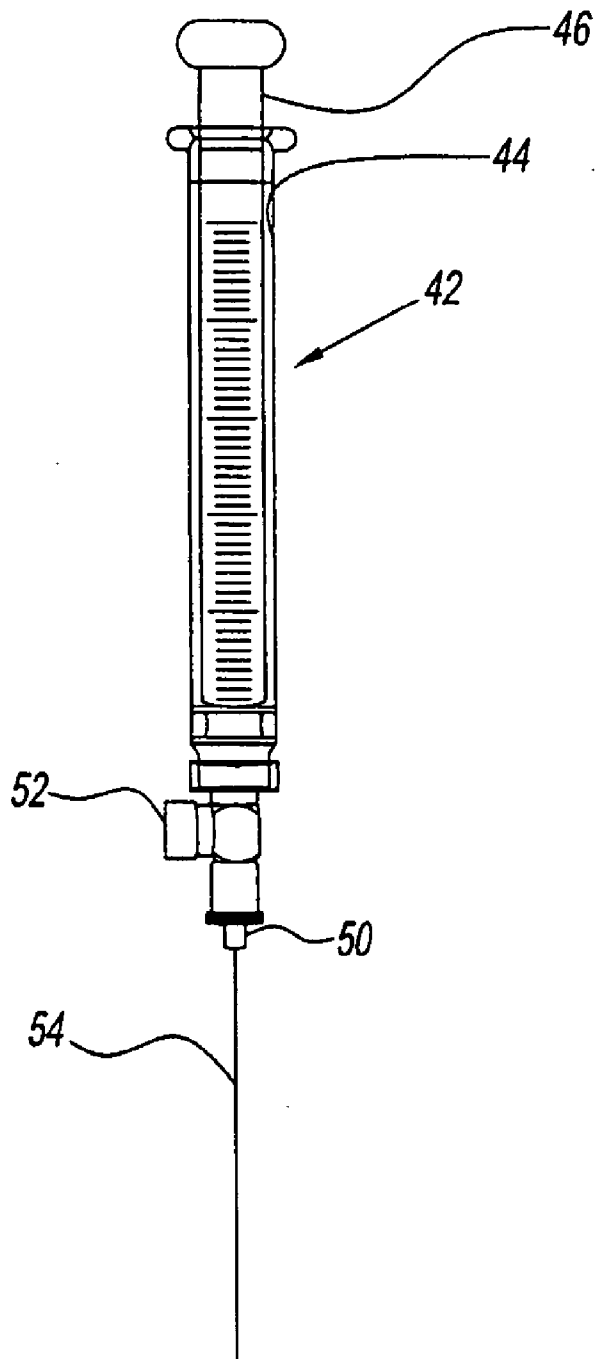

Fig. 6

APPARATUS AND METHOD FOR DISPENSING HIGH PURITY MATERIALS

FIELD OF THE INVENTION

[0001] This invention relates to system or apparatus and a method for dispensing high purity material from a container without compromising the purity of the material. More particularly, the invention relates to a system or apparatus and a method for dispensing high purity chemicals, and particularly ultra dry solvents intended for use in laboratory scale synthesis studies, from a container, and particularly from a positive dispense container or can while maintaining the integrity of the material.

BACKGROUND OF THE INVENTION

[0002] Numerous dispensing systems are known for dispensing materials from pressurized containers. The material to be dispensed in the pressurized container generally provided with a dispensing valve. Upon activation of the valve a pressure differential between the internal pressure in the container and the ambient pressure permits the dispensing of the material from the container. While such a simple system is acceptable for many applications, where the continuing purity and integrity of the material to be dispensed is a prime concern, such systems do not permit the purity and integrity of the material to be maintained upon dispensing of the material. One such material is ultra dry solvent utilized in laboratory scale synthesis studies. Such ultra dry solvents are degraded by contact with moisture and oxygen.

[0003] For large scale storage and dispensing of such ultra dry solvents there is presently available a CYCLE-TAINER container for a solvent delivery system. Such system comprises a closed stainless steel container, available in 4, 8, 52, 215 and 1250 liter sizes, containing the material to be dispensed, and is provided with appropriate valving. In use, an inlet valve of the container is hooked up to a source of pressurized inert gas, such as argon or nitrogen, and the outlet valve from the container is connected to a hose leading directly to the reactor or vessel where the stored material is to be employed or used. Upon introduction of the pressurized gas into the container the material may be dispensed. Cutting off the source of inert gas and closing of the valve stops the dispensing of the material from the container and preserves the integrity of the stored material. Such a system is not suitable, practical or acceptable, however, for conditions where one desires to dispense only small quantities of the material from a positive pressurized container, such as where one desires to dispense from a pressurized container only about 10 to about 20 mL of an ultra dry solvent material for lab scale synthesis studies. One way in which the art has attempted to solve this problem is to employ a syringe and a septum sealed bottle or container that contains, under a blanket of inert gas, the desired material to be dispensed. With this type of apparatus it is necessary for the user to puncture the septum of the bottle with the needle of a syringe to extract the material from the septum container. However, this insertion of the needle into the septum container itself can be a cause of contamination of the material and destroy the integrity of the material. Additionally, the puncturing of the septum leaves a hole in the septum permitting escape of the blanket of inert gas and introduction of atmospheric gas, particularly oxygen, and moisture into the material stored in the septum container.

Thus, there is a definite need for an acceptable dispensing system or apparatus for dispensing a material, especially relatively small amount of material, from a pressurized material that permits the dispensing to occur while maintaining the purity and integrity of the material being dispensed.

SUMMARY OF THE INVENTION

[0004] This invention relates to a system or apparatus and a method for dispensing a material from a pressurized container while maintaining product integrity. The system or apparatus comprises a pressurized container for holding the material and having a dispensing valve provided with a dispensing conduit or stem for dispensing the material from the container at the appropriate time, a syringe equipped with on/off locking mechanism for permitting or preventing flow of the material into and out of the syringe by way of a stem or conduit attached to the locking mechanism, and a removable adaptor for connecting the stem of the syringe to the stem of the dispensing valve of the pressurized container for permitting flow of material from the pressurized container into a chamber of the syringe upon actuation of the dispensing valve.

[0005] In a preferred embodiment of the system or apparatus of this invention the dispensing valve comprises a reciprocally actuated valve wherein, when the syringe stem is connected to the valve stem by way of the adaptor, and the valve stem is reciprocally moved inward towards the interior of the pressurized container, one or more openings in the valve stem are uncovered permitting flow of material from the container to a chamber of the syringe without exposure to any contaminants or reactive materials thereby permitting dispensing of the material while maintaining its integrity. In another preferred feature of this invention, a desiccant is provided for preventing moisture from entering the pressurized container.

[0006] The invention in one embodiment comprises an apparatus for storing and dispensing a material from a pressurized container while maintaining the integrity or purity of the material to be dispensed, the apparatus comprising:

[0007] a) a pressurized container holding the material to be dispensed, the pressurized container having a dispensing valve with a dispensing valve stem having a distal end protruding from the pressurized container and a proximal end extending into the pressurized container;

[0008] b) a syringe provided with 1) an on/off locking member for permitting/or preventing flow of the material into or out of a chamber of the syringe and 2) a stem having an end extending from the syringe for receiving material from the pressurized container; and

[0009] c) a removable adaptor connecting the distal end of the dispensing valve stem protruding from the pressurized container to the end of the stem extending from the syringe so as to establish a permissible flow path from one stem to the other stem;

[0010] so that upon activation of the on/off locking member to the on position, for permitting flow of material into the syringe and activation of the dispens-

ing valve to a dispensing mode, material may flow from the pressurized container to the chamber of the syringe.

[0011] The invention in another embodiment comprises an apparatus wherein the dispensing valve comprises a reciprocally actuated valve.

[0012] The invention in another embodiment comprises an apparatus wherein the valve stem of the dispensing valve is hollow but is closed at the proximal end in the container and is provided with one or more covered openings along the stem, the valve stem being reciprocally movable inward into the pressurized container for uncovering the one or more openings in the valve stem for permitting the flow of material from the pressurized container through the one or more openings, into the valve stem, and into the chamber of the syringe.

[0013] The invention in another embodiment comprises an apparatus wherein the one or more openings in the dispensing valve stem are located circumferentially around the dispensing valve stem and are covered by a gasket until the dispensing valve stem is moved reciprocally inward into the pressurized container for uncovering the one or more openings.

[0014] The invention in another embodiment comprises an apparatus wherein the gasket is a ring of material surrounding the dispensing valve stem in a slidable manner.

[0015] The invention in another embodiment comprises an apparatus wherein the pressurized container holding the material to be dispensed is a positive dispense container comprising a pressurized container having therein a bag containing the material to be dispensed, said bag being connected to the dispensing valve in fluid flow relationship, and said bag being surrounded by pressurizing gas, preferably such as argon or nitrogen, in the container.

[0016] The invention in another embodiment comprises an apparatus wherein the pressurized container holding the material to be dispensed is a positive dispense container comprising a pressurized container having therein a bag containing the material to be dispensed, said bag being connected to the dispensing valve in fluid flow relationship, and said bag being surrounded by pressurizing gas in the container. In a further embodiment a desiccant material may be placed in the space between the pressurized container and the bag therein holding the material to be dispensed, i.e., in the space where the pressurized gas is maintained between the wall of container and bag to prevent any moisture in the container from entering the bag containing the material to be dispensed.

[0017] The invention in another embodiment comprises an apparatus wherein the bag is connected to the dispensing valve through a valve connector, the valve connector having a central opening for permitting the material to flow out of the bag, the dispensing valve stem is seated in the valve connector in a biased manner in a direction outwardly from the pressurized container preventing flow of material out through the valve stem until actuation of the dispensing valve.

[0018] The invention in another embodiment comprises an apparatus wherein the dispensing valve stem is seated upon a biasing spring in the valve connector.

[0019] The invention in another embodiment comprises an apparatus wherein the adaptor comprises two female sockets connected by a central material flow path passageway in the adaptor, one of the female sockets connected to the distal end of the dispensing valve stem and the other female socket connected to the end of the stem of the syringe for permitting the flow of the material from the dispensing valve stem to the syringe stem so that the material may flow from the pressurized container to the chamber of the syringe without exposure to the atmosphere.

[0020] The invention in another embodiment comprises an apparatus wherein the adaptor comprises two female sockets connected by a material flow path, one of the female sockets connected to the distal end of the dispensing valve stem and the other female socket connected to the end of the stem of the syringe for permitting the flow of the material from the dispensing valve stem to the syringe stem so that the material may flow from the pressurized container to the chamber of the syringe.

[0021] The invention in another embodiment comprises an apparatus wherein the on/off locking member on the syringe is a luer lock.

[0022] The invention in another embodiment comprises an apparatus wherein the syringe is provided with a reciprocally actuated piston extending outwardly from the chamber of the syringe at an end of the syringe opposite the syringe stem.

[0023] The invention in another embodiment comprises a method for storing and dispensing a material from a pressurized container while maintaining the integrity or purity of the material to be dispensed, the method comprising:

[0024] a) providing a pressurized container holding the material to be dispensed, the pressurized container having a dispensing valve with a dispensing valve stem having a distal end protruding from the pressurized container and a proximal end extending into the pressurized container;

[0025] b) providing a syringe provided with 1) an on/off locking member for permitting/or preventing flow of the material into or out of a chamber of the syringe and 2) a stem having an end extending from the syringe for receiving material from the pressurized container; and

[0026] c) providing a removable adaptor for connecting the distal end of the dispensing valve stem protruding from the pressurized container to the end of the stem extending from the syringe so as to establish a permissible flow path from one stem to the other stem;

[0027] d) connecting the adaptor to the distal end of the dispensing valve stem protruding from the pressurized container to the end of the stem extending from the syringe; and

[0028] e) activating the on/off locking member to the on position for permitting flow of material into the syringe;

[0029] f) activating the dispensing valve to a dispensing mode permitting material to flow from the pressurized container to the chamber of the syringe; and

[0030] g) activating the on/off locking member to the off position to isolate the material in the chamber of the syringe.

[0031] The invention in another embodiment comprises a method having the additional step of subsequently replacing the stem of the syringe with a needle, activating the on/off locking member to the on position and expelling material from the syringe chamber to a closed system where the material is to be employed.

[0032] The invention in another embodiment comprises a method wherein the dispensing valve comprises a reciprocatably actuated valve.

[0033] The invention in another embodiment comprises a method wherein the valve stem of the dispensing valve is hollow but is closed at the proximal end in the container and is provided with one or more covered openings along the stem, the valve is actuated by the valve stem being reciprocatably moved inward into the pressurized container thereby uncovering the one or more openings in the valve stem and permitting the flow of material from the pressurized container through the one or more openings, into the valve stem, and into the chamber of the syringe.

[0034] The invention in another embodiment comprises a method wherein the one or more openings in the dispensing valve stem are located circumferentially around the dispensing valve stem and are covered by a slidably gasket and when the dispensing valve stem is moved reciprocatably inward into the pressurized container the one or more openings is/are uncovered by the gasket to provide for flow of the material into the one or more openings.

[0035] The invention in another embodiment comprises a method wherein the pressurized container holding the material to be dispensed is a positive dispense container comprising a pressurized container having therein a bag containing the material to be dispensed, said bag being connected to the dispensing valve in fluid flow relationship, and said bag being surrounded by pressurizing gas, preferably argon or nitrogen, in the container, whereby upon activation of the dispensing valve the pressurizing gas forces material from the bag through the dispensing valve and into the syringe chamber.

[0036] The invention in another embodiment comprises a method wherein the bag is connected to the dispensing valve through a valve connector, the valve connector having a central opening for permitting the material to flow out of the bag, the dispensing valve stem is seated in the valve connector in a biased manner in a direction outwardly from the pressurized container preventing flow of material out through the valve stem until actuation of the dispensing valve occurs.

[0037] The invention in another embodiment comprises a method wherein the dispensing valve stem is seated upon a biasing spring in the valve connector and activation of the dispensing valve causes the biasing spring to be contracted permitting the dispensing valve stem to further enter the pressurized container to uncover the gasket from the one or more openings circumferentially around the stem.

[0038] The invention in another embodiment comprises a method wherein the adaptor comprises two female sockets connected by a central material flow path passageway in the adaptor, and the adaptor is connected to the two stems by connecting one of the female sockets to the distal end of the dispensing valve stem and the other female socket to the end of the stem of the syringe.

[0039] The invention in another embodiment comprises a method wherein the material to be dispensed is an ultra dry solvent.

[0040] The invention in another embodiment comprises a method having the additional steps of subsequently replacing the syringe stem with a needle while the locking member is in the off position, and then activating the locking member to the on position and expelling material from the syringe chamber to a closed reactor or vessel.

[0041] The invention in another embodiment comprises a method wherein the material is expelled from the syringe chamber by means of a reciprocatably syringe piston.

BRIEF DESCRIPTION OF THE DRAWINGS

[0042] The invention is illustrated by, but not limited to, the embodiment of the invention shown in the figures wherein:

[0043] FIG. 1 is an exploded view, partially in section, of the apparatus or system of this invention;

[0044] FIG. 2 is an enlarged view of a portion of the apparatus or system of FIG. 1;

[0045] FIG. 3 is a view of the assembled apparatus or system ready for dispensing material from the pressurized container;

[0046] FIG. 4 is a view of the assembled apparatus or system of FIG. 3, partially broken away to show the relative position of the components;

[0047] FIG. 5 is an enlarged view of a portion of the assembled apparatus or system of FIGS. 3 and 4, illustrating the activation of the valve to permit flow of the material out of the pressurized container; and

[0048] FIG. 6 is a view illustrating apparatus to illustrate how the material dispensed into the chamber of the syringe by the apparatus of this invention may be dispensed from the syringe.

DETAILED DESCRIPTION OF THE INVENTION

[0049] The invention is illustrated by, but not limited to, the following description of preferred embodiments of the invention. As shown particularly in FIGS. 1 and 2, the system or apparatus 10 comprises a pressurized container 12 containing the material, particularly an ultra-dry solvent material, to be dispensed. Although any suitable pressurized container can be employed in the apparatus and system of this invention, it is preferred to employ a positive dispense container having a bag of the material in a container pressurized by a suitable pressurizing gas contained in the container but not in the bag. Such positive dispense bags are disclosed, for example in U.S. Pat. Nos. 5,035,351, 5,040,704, 5,137,186 and 5,169,037, the disclosures of which are incorporated herein by reference thereto. As illustrated in FIG. 1, the pressurized container 12 has a material-containing bag 14 in which the material 16 is contained. The bag 14 is exteriorly surrounded by pressurized gas 18 in the container 12. In an embodiment, any suitable desiccant material 58 may be placed in the space between the wall of the pressurized container 12 and the bag 14, i.e., in the space occupied by the pressurized gas 18, to prevent any moisture

resident in the container from entering the bag and contaminating material 16. Any suitable desiccant in any suitable form, e.g., powder or packaged form, may be employed. Preferably the desiccant is a packaged form and comprises packaged silica gel or molecular sieve desiccant, such as those available from Sigma-Aldrich, Inc. of St. Louis, Mo., as Minipax® absorbent packets and from Multisorb Technologies, Inc. of Buffalo, N.Y. as Natrasorb® desiccant packages. The bag 14 containing the material 16 to be dispensed is sealed with a dispensing valve assembly 20 by way of a valve connector 22 suitably sealed to the bag and having a central opening 24 extending through the valve connector. Seated in the central opening 24 of the valve connector 22 is a reciprocable operable hollow valve stem 26, closed at its inner or bottom proximal end to prevent flow of material directly into the proximal end of the valve stem. That closed end of the valve stem is located in the portion of the valve connector 22 extending into the interior of the container 12 and being seated on a biasing structure 28, such as a spring, biasing the distal end of the valve stem outward of the container 12 and doing so in a mode preventing dispersing of the material 16 from the bag 14. The valve stem 26 is provided with one or more circumferentially spaced openings or holes 30 at a location along the valve stem within the central opening 24 of the valve connector 22 located within the interior of the pressurized container 12. Dispensing of the material 16 from the container 12 through openings or holes 30 is prevented by a covering or gasket 32 surrounding the openings or holes when the valve stem 26 is outwardly biased as shown in FIG. 1 and 2. The gasket material 32 may be of any suitable material not detrimental to the material being stored in the bag 14. As an example of such a suitable gasket material there may be mentioned Gasket CS05-0310-51 from Buckeye Rubber & Packing Co., Cleveland, Ohio. It will be understood that the gasket material will be chosen based on its suitability to the material 16 to be contained in the bag 14.

[0050] The apparatus or system 10 of the invention further includes an adaptor 34 having a central passageway 36 through the adaptor and thereby providing female sockets 38, 40 at each end of the adaptor for receiving a male member as explained hereinafter. The adaptor 34 may be of any suitable size or shape suitable for the intended use and made of any material suitably compatible with the material 16 to be dispensed.

[0051] The apparatus or system 10 of this invention further comprises a syringe 42 having a central chamber 44 and provided at one end with a reciprocably actuated piston member 46 extending outwardly from the chamber 44 in a sealing manner and at the other end a on/off mechanism or locking member 48. Extending outwardly from the locking member 48 is a hollow stem or conduit 50 for receiving material 16 from container 12 into syringe chamber 44 and for dispensing the material from the syringe chamber into a reactor or reaction vessel. The locking member 48 may be a luer lock mechanism or any other suitable on/off mechanism. The locking member 48, as illustrated in the FIGS. 1, 3, 4 and 6 has a turnable handle 52, that by appropriate positioning either prevents or permits flow of material through stem 50 into or out of syringe chamber 44.

[0052] As shown in FIGS. 3 and 4, for using the apparatus or system of this invention, the adaptor 34 is connected to both the valve stem 26 of the container 12 and to the stem

50 extending from the syringe 42 by placing the male stems into sealing arrangement with female sockets 38 and 40, respectively, of the adaptor.

[0053] When it is desired to dispense material 16 from bag 14 in container 12, after the syringe stem 50 and container stem 26 are connected by adaptor 34, downward pressure is exerted against biasing means 28, such as by downward movement of the syringe 42, such that stem 26 is forced further into central opening 24 of valve connector 22 as shown in FIG. 5. Gasket 32 remains stationary against the upper end 23 of valve connector 22 as the stem 26 moves downward compressing biasing spring 28 in the central opening 24 thereby exposing the holes or openings 30 previously covered by the gasket. Upon uncovering of the holes or openings 30, pressurized gas 18 in container 12 causes material 16 to flow out of bag 14 and through central opening 24 and then through holes or openings 30 into hollow stem 26, through the adaptor 34, and then through stem 50 into syringe chamber 44 upon positioning handle 52 of locking member 48 to the on (open) position. Once the material is in the syringe chamber 44 the handle 52 of the locking member 48 may be turned to the off (closed) position to isolate the material 16 in the chamber.

[0054] When it is desired to dispense the material 16 that now resides in the syringe chamber 44 the syringe stem 50 is removed from female socket 38 of the adaptor and the stem is replaced with a syringe needle 54 as illustrated in FIG. 6. The material 16 may then be dispensed from the syringe chamber 44 by placing the needle in a closed reactor or vessel (not shown), turning handle 52 to the on (open) position and expelling the desired amount of the material by appropriate movement of syringe piston 46.

[0055] The invention is particularly applicable to an apparatus and a method for dispensing materials that comprises ultra-dry solvents to be dispensed in relatively small amounts of about 200 mL or less, particularly about 100 mL or less, and especially amounts of about 10 ml to about 20 mL, under conditions that require the integrity and impurity of the material to be maintained and exposure to atmospheric conditions or other means of contamination are to be avoided. Examples of such solvent materials include, but are not limited to acetone, acetonitrile, anhydrous alcohols, bis (2-methoxyethyl)ether, chlorobenzene, chloroform, cyclohexane, dimethylformamide, dimethyl sulfoxide, ethyl acetate, ethyl ether, hexanes, methyl tert-butyl ether, methylene chloride, methyl ethyl ketone, tetrahydrofuran, toluene, xylenes and the like

[0056] While the invention has been described herein with reference to the specific embodiments thereof, it will be appreciated that changes, modification and variations can be made without departing from the spirit and scope of the inventive concept disclosed herein. Accordingly, it is intended to embrace all such changes, modification and variations that fall within the spirit and scope of the appended claims.

I claim:

1. Apparatus for storing and dispensing a material from a pressurized container while maintaining the integrity or purity of the material to be dispensed, the apparatus comprising:

- a) a pressurized container holding the material to be dispensed, the pressurized container having a dispensing valve with a dispensing valve stem having a distal end protruding from the pressurized container and a proximal end extending into the pressurized container;
- b) a syringe provided with 1) an on/off locking member for permitting/or preventing flow of the material into or out of a chamber of the syringe and 2) a stem having an end extending from the syringe for receiving material from the pressurized container; and
- c) a removable adaptor connecting the distal end of the dispensing valve stem protruding from the pressurized container to the end of the stem extending from the syringe so as to establish a permissible flow path from one stem to the other stem;
- so that upon activation of the on/off locking member to the on position for permitting flow of material into the syringe and activation of the dispensing valve to a dispensing mode material may flow from the pressurized container to the chamber of the syringe.
2. Apparatus according to claim 1 wherein the dispensing valve comprises a reciprocatably actuated valve.
3. Apparatus according to claim 2 wherein the valve stem of the dispensing valve is hollow but is closed at the proximal end in the container and is provided with one or more covered openings along the stem, the valve stem being reciprocatably movable inward into the pressurized container for uncovering the one or more openings in the valve stem for permitting the flow of material from the pressurized container through the one or more openings, into the valve stem, and into the chamber of the syringe.
4. Apparatus according to claim 3 wherein the one or more openings in the dispensing valve stem are located circumferentially around the dispensing valve stem and are covered by a gasket until the dispensing valve stem is moved reciprocatably inward into the pressurized container for uncovering the one or more openings.
5. Apparatus according to claim 4 wherein the gasket is a ring of material surrounding the dispensing valve stem in a slidable manner.
6. Apparatus according to claim 1 wherein the pressurized container holding the material to be dispensed is a positive dispense container comprising a pressurized container having therein a bag containing the material to be dispensed, said bag being connected to the dispensing valve in fluid flow relationship, and said bag being surrounded by pressurizing gas in the container.
7. Apparatus according to claim 5 wherein the pressurized container holding the material to be dispensed is a positive dispense container comprising a pressurized container having therein a bag containing the material to be dispensed, said bag being connected to the dispensing valve in fluid flow relationship, and said bag being surrounded by pressurizing gas in the container.
8. Apparatus according to claim 7 wherein the bag is connected to the dispensing valve through a valve connector, the valve connector having a central opening for permitting the material to flow out of the bag, the dispensing valve stem is seated in the valve connector in a biased manner in a direction outwardly from the pressurized container preventing flow of material out through the valve stem until actuation of the dispensing valve.
9. The apparatus according to claim 8 wherein the dispensing valve stem is seated upon a biasing spring in the valve connector.
10. The apparatus according to claim 1 wherein the adaptor comprises two female sockets connected by a central material flow path passageway in the adaptor, one of the female sockets connected to the distal end of the dispensing valve stem and the other female socket connected to the end of the stem of the syringe for permitting the flow of the material from the dispensing valve stem to the syringe stem so that the material may flow from the pressurized container to the chamber of the syringe without exposure to the atmosphere.
11. The apparatus according to claim 8 wherein the adaptor comprises two female sockets connected by a material flow path, one of the female sockets connected to the distal end of the dispensing valve stem and the other female socket connected to the end of the stem of the syringe for permitting the flow of the material from the dispensing valve stem to the syringe stem so that the material may flow from the pressurized container to the chamber of the syringe.
12. The apparatus according to claim 11 wherein the on/off locking member on the syringe is a luer lock.
13. The apparatus according to claim 12 wherein the syringe is provided with a reciprocatably actuated piston extending outwardly from the chamber of the syringe at an end of the syringe opposite the syringe stem.
14. The apparatus according to claim 6 wherein a desiccant material is located in the pressurized gas surrounding the bag.
15. The apparatus according to claim 7 wherein a desiccant material is located in the pressurized gas surrounding the bag.
16. A method for storing and dispensing a material from a pressurized container while maintaining the integrity or purity of the material to be dispensed, the method comprising:
- providing a pressurized container holding the material to be dispensed, the pressurized container having a dispensing valve with a dispensing valve stem having a distal end protruding from the pressurized container and a proximal end extending into the pressurized container;
 - providing a syringe provided with 1) an on/off locking member for permitting/or preventing flow of the material into or out of a chamber of the syringe and 2) a stem having an end extending from the syringe for receiving material from the pressurized container; and
 - providing a removable adaptor for connecting the distal end of the dispensing valve stem protruding from the pressurized container to the end of the stem extending from the syringe so as to establish a permissible flow path from one stem to the other stem;
 - connecting the adaptor to the distal end of the dispensing valve stem protruding from the pressurized container to the end of the stem extending from the syringe; and
 - activating the on/off locking member to the on position for permitting flow of material into the syringe;
 - activating the dispensing valve to a dispensing mode permitting material to flow from the pressurized container to the chamber of the syringe; and

g) activating the on/off locking member to the off position to isolate the material in the chamber of the syringe.

17. The method according to claim 16 comprising the additional step of subsequently replacing the stem of the syringe with a needle, activating the on/off locking member to the on position and expelling material from the syringe chamber to a closed system where the material is to be employed.

18. A method according to claim 17 wherein the dispensing valve comprises a reciprocatably actuated valve.

19. A method according to claim 18 wherein the valve stem of the dispensing valve is hollow but is closed at the proximal end in the container and is provided with one or more covered openings along the stem, the valve is actuated by the valve stem being reciprocatably moved inward into the pressurized container thereby uncovering the one or more openings in the valve stem and permitting the flow of material from the pressurized container through the one or more openings, into the valve stem, and into the chamber of the syringe.

20. A method according to claim 19 wherein the one or more openings in the dispensing valve stem are located circumferentially around the dispensing valve stem and are covered by a slidable gasket and when the dispensing valve stem is moved reciprocatably inward into the pressurized container the one or more openings is/are uncovered by the gasket to provide for flow of the material into the one or more openings.

21. A method according to claim 20 wherein the pressurized container holding the material to be dispensed is a positive dispense container comprising a pressurized container having therein a bag containing the material to be dispensed, said bag being connected to the dispensing valve in fluid flow relationship, and said bag being surrounded by pressurizing gas in the container, whereby upon activation of the dispensing valve the pressurizing gas forces material from the bag through the dispensing valve and into the syringe chamber.

22. A method according to claim 21 wherein the bag is connected to the dispensing valve through a valve connector,

the valve connector having a central opening for permitting the material to flow out of the bag, the dispensing valve stem is seated in the valve connector in a biased manner in a direction outwardly from the pressurized container preventing flow of material out through the valve stem until actuation of the dispensing valve occurs

23. A method according to claim 22 wherein the dispensing valve stem is seated upon a biasing spring in the valve connector and activation of the dispensing valve causes the biasing spring to be contracted permitting the dispensing valve stem to further enter the pressurized container to uncover the gasket from the one or more openings circumferentially around the stem.

24. A method according to claim 22 wherein the adaptor comprises two female sockets connected by a central material flow path passageway in the adaptor, and the adaptor is connected to the two stems by connecting one of the female sockets to the distal end of the dispensing valve stem and the other female socket to the end of the stem of the syringe.

25. A method according to claim 24 wherein the material to be dispensed is an ultra dry solvent.

26. A method according to claim 16 wherein the material to be dispensed is an ultra dry solvent.

27. A method according to claim 16 comprising the additional steps of subsequently replacing the syringe stem with a needle while the locking member is in the off position, and then activating the locking member to the on position and expelling material from the syringe chamber to a closed reactor or vessel.

28. A method according to claim 27 wherein the material is expelled from the syringe chamber by means of a reciprocatable syringe piston.

29. The method according to claim 19 wherein a desiccant material is located in the pressurizing gas and absorbs moisture in the container.

* * * * *