

No. 622,580.

Patented Apr. 4, 1899.

H. H. WING.
MECHANICAL DRIER.

(Application filed Dec. 12, 1895.)

(No Model.)

2 Sheets—Sheet 1.

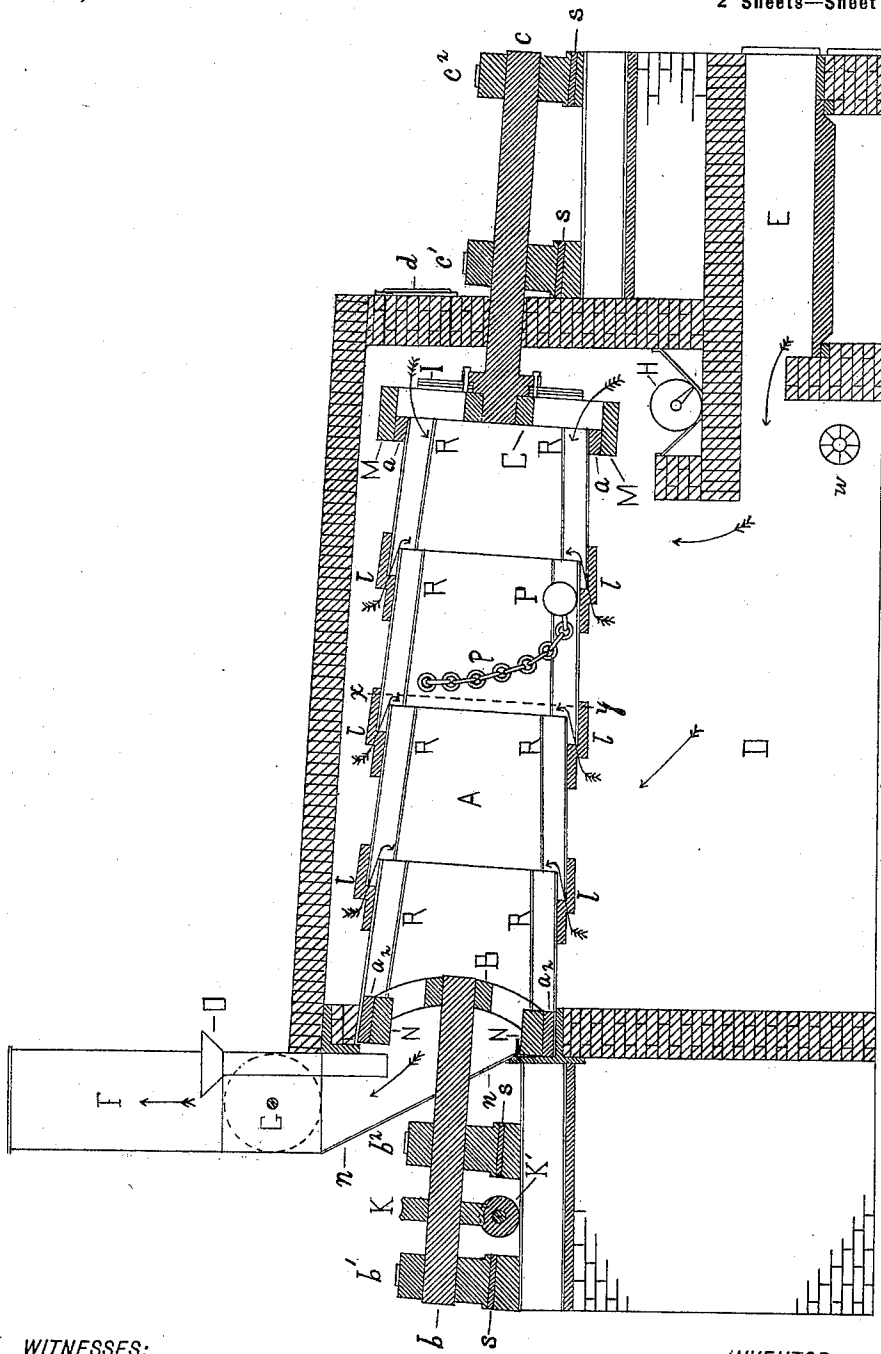

Fig. 1

WITNESSES:

John G. Ullmann
Louis F. Wing

INVENTOR
Herbert H. Wing.

BY
W. M. Wood
ATTORNEY.

No. 622,580.

Patented Apr. 4, 1899.

H. H. WING.
MECHANICAL DRIER.

(Application filed Dec. 12, 1895.)

(No Model.)

2 Sheets—Sheet 2.

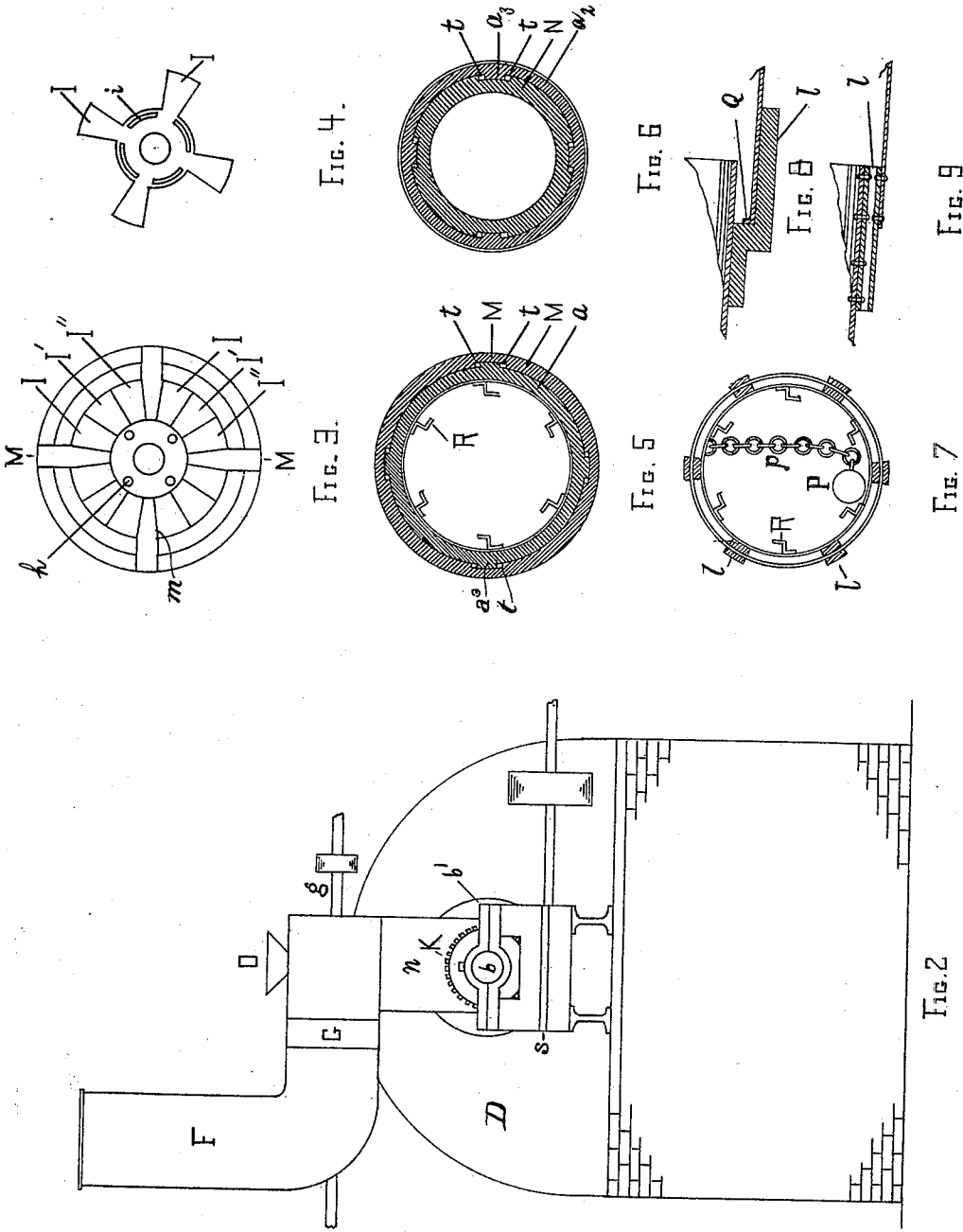

WITNESSES:

John G. Ullmann
Louis F. Wing.

INVENTOR

Herbert H. Wing.

BY

W. H. [Signature]
ATTORNEY.

UNITED STATES PATENT OFFICE.

HERBERT H. WING, OF BUFFALO, NEW YORK.

MECHANICAL DRIER.

SPECIFICATION forming part of Letters Patent No. 622,580, dated April 4, 1899.

Application filed December 12, 1895. Serial No. 571,908. (No model.)

To all whom it may concern:

Be it known that I, HERBERT H. WING, a citizen of the United States, residing at Buffalo, in the county of Erie and State of New York, have invented certain new and useful Improvements in Mechanical Driers; and I do hereby declare the following to be a full, clear, and exact description of the invention, such as will enable others skilled in the art to which it appertains to make and use the same.

My invention relates to improvements in mechanical drying apparatus designed for the rapid and economical drying of all kinds of materials which are to be treated in a fragmentary, granular, or comminuted condition, the present form of my invention relating particularly to the class of rotary cylindrical driers.

The object of my invention is to simplify the construction, increase the efficiency, and secure the most economical operation of the apparatus.

To this end the invention consists in the novel features of construction, combination, and arrangement of the various features of the apparatus, as hereinafter fully described, and pointed out in the claims.

In the drawings hereto annexed, Figure 1 represents, mostly in central longitudinal section, a drying apparatus in which my invention is embodied. Fig. 2 is a front end elevation of the same. Fig. 3 is a rear end elevation of the drying-cylinder, showing the supporting spider and damper at the discharge end. Fig. 4 is a detached view of one of the damper-plates. Fig. 5 is a transverse section through the cylinder, the ring a , and rim M of the spider C. Fig. 6 is a transverse section through the cylinder, the rim N of spider B, and the ring a^2 at the feed end of the cylinder. Fig. 7 is a transverse section through the drying-cylinder, taken on the line xy of Fig. 1. Fig. 8 is a detail showing a modification of the construction of the shell, and Fig. 9 is a detail showing a modified or alterative method of securing the sections together.

Heretofore there has been found in the use of revolving-cylinder driers considerable difficulty in securing an even and continuous discharge of the dried material through and out of the cylinder, owing to the fact that in

nearly all such driers the interior surface of the cylinder is more or less obstructed by rigid internal constructions—such as stirring devices, air-inlets, and transverse ribs or shoulders—against or upon which portions of the material being treated lodge from time to time, the presence of which is apt to cause temporary accumulation of the material and an intermittent and irregular discharge. One of the objects of the present invention is to provide a construction of cylinder in which the passage of the material along the same shall be unobstructed and a smooth uninterrupted surface lengthwise of the cylinder provided for the passage of the material, while at the same time providing ample means for inletting the hot air and products of combustion, by means of which the drying is largely effected. Another important end in view is the more efficient regulation and control of the supply of air and drying-gases admitted to the drying-cylinder, the purpose being to evenly distribute the heat and prevent the excessive heating of the material in certain parts of the apparatus and to prolong the life of the apparatus itself. I have found that in drying certain classes of material when a perfectly plain rotating cylinder is used the capacity of such apparatus was limited within certain very definite limits, and that to evenly dry and not overheat any portion of the material required extreme care, and that when running such a drier at its utmost capacity it is impossible to prevent at times the excessive heating of the discharged material, whereby some of the product was injured, or to prevent at times some portions of the material from being discharged before it was sufficiently dry. When using, on the other hand, a drying-cylinder containing internal structures such as before referred to, there was found great liability of the material to lodge and accumulate in certain parts of the apparatus, whereby the drying of such masses was rendered incomplete and the subsequent discharging of such masses of material occurred in a sudden rush, whereby imperfectly-dried material was discharged and the conveyer overloaded, causing very great annoyance and delay. Another difficulty which has presented itself in the use of driers of the rotating-cylinder class has been due to the fact that the en-

trance of the hot drying-gases at the discharge end of the cylinder has been freer than at other portions of the cylinder, the result of which has been that as the material at this end is thoroughly dry or intended to be it is the more easily overheated and burned or injured, while from the same cause the discharge end of the cylinder and the metal parts of the apparatus adjacent thereto have been too highly heated, so as to cause in many cases breakage and derangement of the apparatus. In order to overcome the foregoing and other difficulties, I have devised the construction shown in the drawings, wherein—

A represents the drying-cylinder, supported by spiders B C at the feed end and discharge end, respectively, the spiders being supported, respectively, upon heavy trunnions or shafts b c , supported in suitable bearings b^1 b^2 and c^1 c^2 , which I prefer to locate entirely outside of the chamber in which the drying-cylinder is located. By this means I avoid the possibility of the bearing being heated and the operation of the cylinder interfered with from that cause. The cylinder A is set with the discharge end so much lower than the feed end as to give the proper slope thereto, according to the nature of the materials being dried. In drying any material containing an unusual amount of moisture the slope of the cylinder A may with advantage be made less than when drying material containing a less percentage of moisture, which is more or less pulverulent when nearly dried. For the purpose of changing to some extent the slope of the cylinder I prefer to make the bearings b^1 b^2 vertically adjustable, which may be accomplished by any suitable means, but most simply by inserting plates s of suitable thickness beneath the bearings. The cylinder is suspended within a chamber D, which is closed to the external air, but in open connection with a furnace E, located at one end or the other of the chamber D, wherein by the combustion of any suitable fuel or by the use of hot waste gases from any other source the heat for drying the material in the cylinder is obtained. If it be found necessary to reduce the heat at any time, this is readily accomplished by admitting air through the doors of the furnace E in the usual way, and to provide for emergencies an opening or openings w may be provided in the walls of the chamber D near the bottom and preferably near the discharge end of the cylinder, as shown, and supplied with suitable covers or dampers, whereby the admission of air to the chamber D may be effected and regulated at will if in any case more air is desired than can be admitted through the furnace-doors.

The upper or feed end of the cylinder communicates directly with a stack F, conveniently located. In a short horizontal pipe f at the bottom part of the stack a suitable fan G is placed and actuated by a shaft and pulley g , by means of which a draft through the cylinder is maintained and can be very ex-

actly regulated. Beneath the discharge end of the cylinder is located a conveyer H, transverse to the axis of the cylinder, which conveys away the material falling from the cylinder and delivers it at any suitable point of discharge. I prefer to employ a spiral conveyer of the ordinary form; but an endless-belt conveyer or any other of the well-known forms of conveyer may be used, if preferred.

The spider C, which supports the discharge end of the cylinder A, is so constructed as to carry a damper I, which is capable of nearly closing the discharge end of the cylinder when shut. The damper I may be placed within the spider; but I prefer to place the same external to the spider, as shown in Fig. 1, where it is more readily accessible. The spider C, having radial arms m and annular rim M or equivalent, engages the outside of the cylinder, fitting upon a ring a , secured to the discharge end of the cylinder, and which ring by lugs a^3 or recesses therein engages corresponding lugs or recesses t on the inner side of the rim M, so as to secure the rotation of the spider C with the cylinder. The damper I may be of any preferred construction, but, as shown, consists of stellate or cruciform plates I I' I'', &c., seated upon the shaft c , outside the arms m , and having segmental slots i , through which pass bolts h . The plates I I' I'', &c., slide freely one over the other, but so snugly that they will remain in the position in which they are placed. In Fig. 3 they are shown as arranged to close the entire end of the cylinder, leaving only an annular space about equivalent to that between the sections of the shell, and by turning them so that they coincide in position the end is left nearly uncovered. The spider B has also radial arms, which terminate in an annular rim N, which engages in the same manner as spider C a ring a^2 , secured to the feed end of the cylinder, and thus effects the rotation of the cylinder when the spider B is turned by means of suitable gear, as K, affixed to the shaft b and actuated by any suitable power, as K'. I prefer to use a worm and gear wheel, as they occupy less space and make less noise than other constructions. Obviously the ends of the spider-arms might be prolonged parallel with the axis of the cylinder and the rims M N dispensed with, the lugs or sockets t being on the spider-arms; but I prefer to employ the annular rims, for the double reason that they strengthen the spiders by joining the ends of their arms and they tend to prevent the warping of the spider-arms by heat and better preserve the freedom of the cylinder to move longitudinally as it expands or contracts; and for this purpose I prefer to form the sockets t a little wider than the lugs which seat therein, as seen in Figs. 5 and 6, so that they cannot bind under the effects of the expansion and contraction.

The shell A is of the following construction: A number of conical, or, if preferred, cylindrical sections are secured together in

such manner that beginning at the feed end each section enters within the succeeding one to a distance of several inches, leaving an annular space between the two sections, 5 which may be about two inches, more or less, in radial width. The sections of the shell, which may be of any desired number, may be polygonal in outline, but are preferably circular, and are secured together by any 10 suitable means, as by external bars *ll*, placed at intervals around the cylinder, as shown in Fig. 7, thus forming an exceedingly rigid cylinder provided with ample inlet-openings between the several sections, which, however, 15 offer no obstruction to the downward passage through the cylinder of the material being dried. The bars *ll* may be straight and extend between the sections, where they lap, as shown in Fig. 9; but they are preferably Z-shaped and extend outside of both sections, 20 as seen in Figs 1 and 8.

To more completely subject the material being dried to the action of the hot gases which fill the cylinder A, the sections of the 25 cylinder are provided with longitudinal inward-extending ledges R, firmly secured to the shell, the sections being thus rendered extremely rigid, and the danger of warping to which the cylinders of driers are peculiarly 30 liable practically obviated.

In the operation of the drier as thus constructed the material to be dried is fed into a hopper O at the feed end of the machine, and falling upon the inclined hood *n*, which closes 35 the feed end of the cylinder and communicates with the stack F, is discharged into cylinder A and is caught upon the upper end of the first ledge R of the rotating cylinder A, and being carried up the ascending side of 40 the cylinder falls back to the bottom thereof at a point lower down, encountering the current of hot combustion-gases from the furnace E, which, entering the cylinder at the annular spaces between the sections and at the 45 narrow peripheral spaces at the discharge end, fill the cylinder, already heated by the external contact therewith throughout its whole surface of the hot combustion-gases which fill the chamber D, and rapidly extract from 50 the material the moisture contained therein and being drawn out by the fan G escape through the stack F. The material to be dried, being entirely unobstructed by shoulders, bands, braces, or like internal structures, 55 drops from the ledges R continuously through the hot current of gases and meeting as they drop from section to section of the shell the incoming current of hot and dry gases have no tendency or opportunity to lodge or accumulate in masses or to descend in sudden 60 bursts, but pass evenly and continuously down the smooth inner surface of the cylinder and escape in a continuous discharge at the lower end thereof. As a precaution, however, 65 against the adhering to and, as it were, baking or sticking upon the interior surface of the shell of moist and sticky material I

provide a jarring arrangement to dislodge any adhering material, to which end I attach to the cylinder (preferably internally) one or 70 more balls P by means of chains *p*, which ball, being carried up by the ledges R, drops upon the bottom of the shell with sufficient force to jar loose any adhering material which 75 may have baked or stuck upon the interior of the cylinder and causes the same to drop to the bottom thereof. By this ball a continuous jarring is effected which practically prevents the adherence of any of the material to the hot shell of the cylinder. When the 80 drying operation is finished, by admitting the external air, after banking or drawing the fires in the furnace E, continuing the rotation of the cylinder for a short time, the cylinder may be readily cooled without the possi- 85 bility of its sagging or warping and becoming distorted in shape.

In order to prevent any small amount of dried material from getting through the annular spaces where the sections lap, which, 90 however, is not likely to occur, the sections may be provided with an inward flange Q at their upper end, as seen in Fig. 8, which will prevent any material which may chance to fall or slide into the annular space from es- 95 caping. This will, however, seldom be found necessary, as the rotation of the inclined surface of the cylinder tends to cause the material when it falls from the ledges R or slides 100 down the side of the cylinder to move away from the annular space instead of toward it. The door *d* (shown in Fig. 1) is secured to a large iron plate, and through it the damper I can be easily adjusted. If thought best, 105 bricks can be laid in loose behind the plate and can be removed when the damper is to be regulated or when the iron plate to which this door is attached is removed to make any repairs or when the inside of the drier is to be inspected. 110

What I claim, and desire to secure by Letters Patent, is—

1. In a rotary drying apparatus the cylinder made in sections one discharging into the other and having inlets for drying-gases be- 115 tween the sections, substantially as described.

2. In a rotary drying apparatus the cylinder made in sections one inserted into the other with an annular space between, said sections having internal longitudinal ribs, 120 substantially as described.

3. In a rotary drying apparatus the cylinder composed of sections internally flanged at their upper ends and having longitudinal internal ribs, said sections being inserted one 125 within the other and rigidly secured together with an annular space between the flange of one section and the body of the next for the admission of drying air or gases, substantially as described. 130

4. In a rotary drying apparatus the combination with the cylinder made in sections one inserted into the other and having gas-inlets between the sections, of a damper arranged

across the discharge end of the cylinder and adapted to substantially close the same, substantially as described.

5 In a rotary drying apparatus the combination of the cylinder made in sections one inserted into the other and having gas-inlets between the sections, of the spiders supporting the cylinder and the damper externally attached to the spider which carries the discharge end of the cylinder and adapted to
10 nearly close the end of the cylinder, substantially as described.

6. The combination of the cylinder composed of sections inserted one into the other
15 with an annular space between, and rigidly secured together, whereby they are maintained in the proper relation to each other, internal ribs or ledges extending lengthwise of said sections, spiders supporting the ends
20 of the cylinder, means for rotating said cyl-

inder, and a damper at the discharge end of said cylinder adapted to nearly close the same, substantially as described.

7. In a drying apparatus the combination of the cylinder composed of internally-ribbed sections inserted one into the other with an annular space between for inletting the drying air and gases, means for rotating said cylinder, balls or weights attached by chains to the interior of the cylinder, a damper at the discharge end of the cylinder adapted to nearly close the end of the cylinder, and a furnace for supplying heat to said cylinder, substantially as described.

In testimony whereof I hereto affix my signature in presence of two witnesses.

HERBERT H. WING.

Witnesses:

JOHN G. ULLMANN,
CHAS. S. BOARDMAN.