

(19) World Intellectual Property Organization  
International Bureau



(43) International Publication Date  
25 March 2010 (25.03.2010)

PCT

(10) International Publication Number  
**WO 2010/033992 A1**

(51) International Patent Classification:  
A61N 1/00 (2006.01)

(21) International Application Number:  
PCT/US2009/057854

(22) International Filing Date:  
22 September 2009 (22.09.2009)

(25) Filing Language: English

(26) Publication Language: English

(30) Priority Data:  
61/099,095 22 September 2008 (22.09.2008) US

(71) Applicant (for all designated States except US):  
PHYSIO-CONTROL, INC. [US/US]; 11811 Willows  
Road NE, Redmond, WA 98052 (US).

(72) Inventors; and

(75) Inventors/Applicants (for US only): **ABBENHOUSE, Martin** [US/US]; 12211 NE 66th Street, Kirkland, WA 98033 (US). **MEEKER, Dallas E.** [US/US]; 14253 87th Court, NE, Bothell, WA 98011 (US). **WUNG, Peter** [US/US]; 4514 159th Avenue NE, Redmond, WA 98052 (US). **HIRSCHFELD, Simon L.** [DE/DE]; Kaemmerer-ruf, 22303 Hamberg (DE).

(74) Agent: **KELLY, Jason D.**; Shumaker & Sieffert, P.A., 1625 Radio Drive, Suite 300, Woodbury, MN 55125 (US).

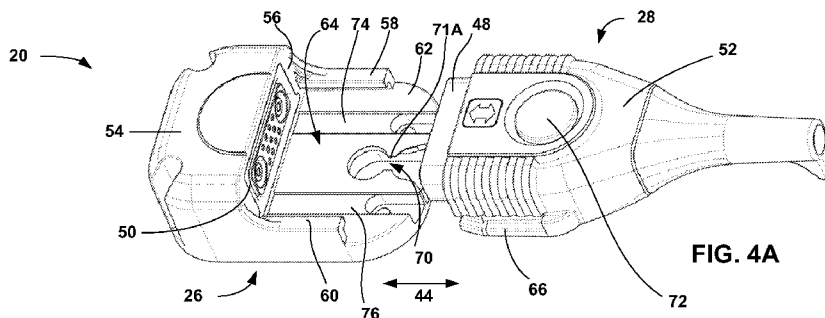
(81) Designated States (unless otherwise indicated, for every kind of national protection available): AE, AG, AL, AM, AO, AT, AU, AZ, BA, BB, BG, BH, BR, BW, BY, BZ, CA, CH, CL, CN, CO, CR, CU, CZ, DE, DK, DM, DO, DZ, EC, EE, EG, ES, FI, GB, GD, GE, GH, GM, GT, HN, HR, HU, ID, IL, IN, IS, JP, KE, KG, KM, KN, KP, KR, KZ, LA, LC, LK, LR, LS, LT, LU, LY, MA, MD, ME, MG, MK, MN, MW, MX, MY, MZ, NA, NG, NI, NO, NZ, OM, PE, PG, PH, PL, PT, RO, RS, RU, SC, SD, SE, SG, SK, SL, SM, ST, SV, SY, TJ, TM, TN, TR, TT, TZ, UA, UG, US, UZ, VC, VN, ZA, ZM, ZW.

(84) Designated States (unless otherwise indicated, for every kind of regional protection available): ARIPO (BW, GH, GM, KE, LS, MW, MZ, NA, SD, SL, SZ, TZ, UG, ZM, ZW), Eurasian (AM, AZ, BY, KG, KZ, MD, RU, TJ, TM), European (AT, BE, BG, CH, CY, CZ, DE, DK, EE, ES, FI, FR, GB, GR, HR, HU, IE, IS, IT, LT, LU, LV, MC, MK, MT, NL, NO, PL, PT, RO, SE, SI, SK, SM, TR), OAPI (BF, BJ, CF, CG, CI, CM, GA, GN, GQ, GW, ML, MR, NE, SN, TD, TG).

Published:

— with international search report (Art. 21(3))

(54) Title: ELECTRICAL CONNECTION ASSEMBLY FOR MEDICAL DEVICES



(57) Abstract: In one example, the disclosure relates to an external defibrillator for delivering stored electrical energy to a patient via electrodes that terminate in a first connector that can be coupled to the external defibrillator. The external defibrillator comprises a housing, an energy storage device within the housing for storing the electrical energy, and a second connector provided on the housing so as to define an insertion path. The first connector can be aligned with the insertion path, and slid along the insertion path substantially parallel to an outer surface of the housing on which the second connector is provided for coupling to the second connector.



WO 2010/033992 A1

## **ELECTRICAL CONNECTION ASSEMBLY FOR MEDICAL DEVICES**

### **TECHNICAL FIELD**

[0001] The invention relates to medical devices and, more particularly, electrical connection assemblies for connecting electrical conductor components of medical devices.

### **BACKGROUND**

[0002] Medical devices used to monitor and/or provide therapy to a patient may include one or more detachable electrical components that can be optionally connected and disconnected to the device via an electrical connection assembly. For example, an external defibrillator device may be connected to an electrical lead via a connector on the exterior of the defibrillator device housing which receives a corresponding electrical connector provided at the proximal end of the electrical lead. Using such a connection, the electrical lead may be physically and electrically coupled to the defibrillator device.

[0003] Electrical leads that are connected to a defibrillator device via an electrical connection assembly may deliver energy in the form of a defibrillation pulse generated by the defibrillator to a heart that is undergoing ventricular fibrillation, e.g., via one or more electrodes on the electrical leads that are coupled to a patient. Furthermore, electrical leads connected to a defibrillator device via an electrical connection assembly may also include electrodes or other sensors or transducers for sensing one or more patient physiological parameters. For example, electrodes carried by one or more electrical leads connected to a defibrillator device may sense electrical signals attendant to the depolarization and repolarization of the heart, which may be displayed to a user in the form of an ECG by the defibrillator. In each case, it is important to provide and maintain a reliable physical and electrical connection between an external defibrillator device and an electrical lead so that the defibrillator device may perform effectively when it is operated by a user.

## SUMMARY

[0004] In general, the disclosure relates to electrical connection assemblies used to connect electrical conductor components of medical devices. An electrical connection assembly may include a first connector that is configured to couple to a second connector to couple respective electrical components. In some examples, an example electrical connection assembly may be used to electrically and physically couple one or more electrical conductors, such as electrical leads, to a medical device, such as, e.g., a defibrillator device, via the electrical connection assembly. In some examples, such medical devices are located external to a human patient, as opposed to internally, e.g., an implantable medical device within the patient.

[0005] In one example, the disclosure is directed to an external defibrillator for delivering stored electrical energy to a patient via electrodes that terminate in a first connector that can be coupled to the external defibrillator, the external defibrillator comprising a housing, an energy storage device within the housing for storing the electrical energy, and a second connector provided on the housing so as to define an insertion path, in which the first connector can be aligned with the insertion path, and slid along the insertion path substantially parallel to an outer surface of the housing for coupling to the second connector.

[0006] In another example, the disclosure is directed to a method for coupling to an external defibrillator electrodes that terminate in a first electrical connector, the external defibrillator including a housing, an energy storage device within the housing for storing electrical energy, and a second electrical connector provided on the housing so as to define an insertion path, the method comprising aligning the first connector with the insertion path, and then sliding the first connector along the insertion path substantially parallel to an outer surface of the housing until the first connector becomes coupled with the second connector, for ultimately delivering the stored electrical energy to a patient via the electrodes.

[0007] In another example, the disclosure is directed to an electrode assembly for delivering stored electrode energy to a patient from an external defibrillator that includes a second connector that can be coupled to the electrode assembly, in which the second connector is provided on a housing of the external defibrillator so

as to define an insertion path, the electrode assembly comprising an electrical cable, a first connector coupled to the cable, and at least one electrode that terminates in the first connector, in which the first connector can be aligned with the insertion path defined by the second electrical connector, and slid along the insertion path substantially parallel to an outer surface of the housing of the external defibrillator for coupling to the second connector.

**[0008]** In another example, the disclosure is directed to an electrical connection assembly comprising a male plug connector coupled to the proximal end of an electrical lead; and a female receptacle connector provided on a first surface of a housing of a medical device, the male plug configured to connect to the female receptacle according to a side insertion path, wherein the electrical connection assembly electrically and physically couples the electrical lead to the medical device when the male plug and female receptacle are connected to each other.

**[0009]** In another example, the disclosure is directed to a system comprising a medical device including a housing, the housing containing electrical circuitry configured for storing electrical stimulation energy, wherein a first electrical connector is coupled to a major surface of the housing; and an electrical lead for delivering the electrical stimulation energy from the medical device to a patient, the electrical lead including a second electrical connector on a proximal end, wherein one of the electrical connectors is a male plug connector and the other of the electrical connectors is a female plug connector, wherein the male plug is configured to connect to the female receptacle according to a side insertion path, wherein the medical device is electrically and physically coupled to the electrical lead when the male plug and female receptacle are connected to each other.

**[0010]** In another example, the disclosure is directed to a method comprising connecting a proximal end of an electrical lead to a medical device via an electrical connection assembly, the electrical connection assembly comprising a first electrical connector coupled to the proximal end of the electrical lead, and a second electrical connector provided on a first surface of a housing of the medical device, wherein one of the electrical connectors is a male plug connector and the other of the electrical connectors is a female plug connector, and wherein the male plug is

configured to connect to the female receptacle according to a side insertion path, wherein the electrical connection assembly electrically and physically couples the electrical lead to the medical device when the male plug and female receptacle are connected to each other.

### **BRIEF DESCRIPTION OF DRAWINGS**

[0011] FIG. 1 is a conceptual diagram illustrating an example system that includes an external defibrillator that may provide defibrillation pulses to a patient.

[0012] FIG. 2 is a schematic block diagram further illustrating the example system of FIG. 1

[0013] FIG. 3 is a perspective diagram illustrating an example system including an example electrical connection assembly.

[0014] FIGS. 4A and 4B are perspective diagrams illustrating the example electrical connection assembly of FIG. 3.

[0015] FIGS. 5A-5H are diagrams illustrating an example male connector of an example electrical connection assembly from various views.

[0016] FIGS. 6A-6H are perspective diagrams illustrating the example female receptacle connector of an example electrical connection assembly from various views.

[0017] FIGS. 7A-7D are cross-sectional diagrams illustrating the connection of an example male plug connector to an example female receptacle connector.

[0018] FIGS. 8A and 8B are diagrams illustrating another example electrical connection assembly.

[0019] FIGS. 9A and 9B are diagrams illustrating another example electrical connection assembly.

[0020] FIGS. 10A and 10B are perspective diagrams illustrating another example electrical connection assembly.

[0021] FIGS. 11A and 11B are perspective diagrams illustrating another example electrical connection assembly.

[0022] FIGS. 12A and 12B are perspective diagrams illustrating another example electrical connection assembly.

[0023] FIGS. 13A and 13B are perspective diagrams illustrating another example electrical connection assembly.

### DETAILED DESCRIPTION

[0024] FIG. 1 is a conceptual diagram illustrating an example system 10 that includes an external defibrillator 12 that may provide defibrillation pulses to a patient 14. System 10 includes defibrillator 12 and electrical cable 22. Electrical cable 22 includes electrical leads 16A and 16B (collectively “leads 16”). Electrodes 18A and 18B (collectively “electrodes 18”) are provided on the distal ends of electrical leads 16A and 16B, respectively, such that they are electrically coupled to leads 16.

[0025] As shown in FIG. 1, defibrillator 12 is coupled to a patient 14 via electrodes 18 and leads 16, which may allow defibrillator 12 to monitor and/or deliver stimulation therapy to patient 14. For example, defibrillator 12 may generate stimulation energy, e.g., in the form of a defibrillation pulse, that is delivered to patient 12 via electrodes 18 on leads 16 of cable 22. Defibrillator 12 may store the stimulation energy within an energy storage device located within the defibrillator housing. As another example, as configured, defibrillator 12 may also monitor electrical activity of patient 12, e.g., electrical activity of the heart of patient 12, using electrodes 18.

[0026] Electrical leads 16A and 16B of cable 22 may be electrically and physically coupled to defibrillator 12 via electrical connection assembly 20. Electrical connection assembly may include a first connector and a second connector. For example, electrical connection assembly 20 may include female receptacle (not shown) provided on defibrillator 12, and male plug (not shown) provided on the proximal end of cable 22. Alternatively, the male plug may be provided on defibrillator 12 and female receptacle provided on the proximal end of cable 22.

[0027] When connected, the configuration of the first and second connectors allows for proximal end of cable 22 to be physically coupled to defibrillator 12 via electrical connection assembly 20. Furthermore, the first and second connectors may include mated electrical connectors which allow electrical signals to be conducted between defibrillator 12 and cable 22 through electrical connection

assembly 20. Accordingly, when the first and second connectors are physically connected to one another, cable 22 is electrically coupled to defibrillator 12. In this manner, electrical stimulation generated by defibrillator 12 may be conducted to leads 16 of cable 22 and electrodes 18 through electrical connection assembly 20.

**[0028]** For ease of illustration, in the examples described herein, the male plug of connection assembly 20 is provided on cable 22 and female receptacle of electrical connection assembly 20 is provided on defibrillator 12. However, it is recognized that in some examples, system 10 may be suitably configured with the male plug provided on defibrillator 12 and female receptacle on cable 22. Accordingly, examples of system 10 may include either or both configurations.

**[0029]** In general, electrical connection assembly includes a first connector and a second connector. Example first and second connectors include a male plug connector and female receptacle connector, which will be generally used to describe examples of the present disclosure. However, other suitable types of connectors for first and second connectors are contemplated.

**[0030]** As will be described in further detail below, defibrillator 12 may deliver external energy stored in an energy storage device to patient 12 via electrodes 18 which terminate in the first connector (e.g., plug connector) of electrical connection assembly 20. The first connector may be coupled to defibrillator 12 via the second connector (e.g., receptacle connector) provided on the housing of defibrillator 12. The second connector may be provided on the housing so as to define an insertion path, where the first connector may be aligned with the insertion path, and slid along the insertion path substantially parallel to an outer surface of the housing of the defibrillator on which the second connector is provided for coupling to the second connector. When the first and second connectors are coupled with one another, electrical stimulation energy may be delivered from the defibrillator 12 to patient 14 via electrodes 18.

**[0031]** FIG. 2 is a schematic block diagram further illustrating the example system 10 of FIG. 1. As in FIG. 1, in FIG. 2, defibrillator 12 is shown coupled to patient 14 by electrodes 18 and leads 16 of cable 22. Although two electrodes 18A and 18B are shown in FIG. 2, defibrillator 12 may be coupled to patient 14 by any number

of electrodes. In some examples, for example, defibrillator 12 is coupled to patient 14 by twelve or more electrodes 18. Furthermore, system 10 may include any number of leads connected to defibrillator via any number of connection assemblies.

**[0032]** Defibrillator 12 is coupled to patient 14 in order to facilitate the treatment of patient 14, e.g., sensing electrical activity of the heart of patient 14 and delivering defibrillation pulses generated by defibrillator 12 to patient 14 via electrodes 18. Electrodes 18 may include hand-held electrode paddles or adhesive electrode pads placed on the skin of patient 14.

**[0033]** Electrodes 18 are coupled to defibrillator 12 via respective leads 16 of cable 22 and interface 24 of defibrillator 12. Proximal end of cable 22 is coupled to interface 24 of defibrillator 12 via electrical connection assembly 20 which includes male plug 28 and female receptacle 26. Electrodes 18 terminate at male plug 28, e.g., one or more conductors of electrode 18 which run through leads 16 of cable 22 terminate at male plug 28. As indicated in the example of FIG. 2, interface 24 includes female receptacle 26 which mates with male plug 28 provided at the proximal end of cable 22 to electrically and physically couple cable 22 to defibrillator 12.

**[0034]** As will be described in greater detail below, in some examples, electrical connection assembly 20 may be configured such that plug 28 may be inserted into receptacle 26 according to a side insertion path. Receptacle 26 may be provided on housing of defibrillator so as to define the insertion path. For example, receptacle 26 may be mounted on a first surface of defibrillator 12, and may be configured to receive plug 28 along a plane substantially parallel to the first surface of defibrillator 12, i.e., the surface of defibrillator 12 on which receptacle 26 is mounted. Such a side insertion path may be utilized rather than requiring a plug or receptacle at the proximal end of a cable to be inserted into a defibrillator connection along a path that is substantially orthogonal to the connection surface of the defibrillator, e.g., similar to that of a conventional electrical appliance plug being inserted into a receptacle into a wall.

**[0035]** Additionally, in some examples, electrical connection assembly 20 may provide for a low-profile connection of cable 22 to defibrillator 12. In such a

configuration, a low-profile connection may reduce the physical protrusion of electrical connector 20 from the surface of defibrillator 12 compared to other types of connection assemblies, thereby minimizing undesirable external contact with connection assembly 20 during transport, use and/or storage that may damage electrical connection assembly 20.

[0036] Furthermore, electrical connection assembly 20 may alternatively, or additionally, include a locking mechanism that secures plug 28 to receptacle 26 in a configuration that provides suitable electrical coupling between defibrillator 12 and cable 22. Such a locking mechanism may allow for electrical connection assembly 20 to provide for secure and reliable physical coupling, in addition to secure and reliable electrical coupling, between cable 22 to defibrillator 12. Examples of such locking mechanism are described in further detail below.

[0037] In some examples, a locking mechanism may also include a release mechanism, e.g., a quick release mechanism, to allow a user to easily disconnected plug 28 from receptacle 26. As one example, electrical assembly 20 may include a release button, e.g., a quick-release button, which may be depressed by a user to disengage the locking mechanism. In this manner, cable 22 may be quickly and/or easily disconnected from defibrillator 12 despite the locking mechanism of electrical assembly 20 that secures plug 28 to receptacle 26 when connected.

[0038] Furthermore, electrical connection assembly 20 may alternatively, or additionally, include an alignment mechanism which allows the respective electrical connectors of plug 28 and receptacle 26 to be properly aligned when plug 28 and receptacle 26 are connected to one another by a user. For example, an alignment mechanism may allow the conductive pins of an electrical connector to engage the recesses of a corresponding electrical connector along the proper insertion path to prevent the pins from bending or breaking off when plug 28 and receptacle 26 are connected by a user.

[0039] Furthermore, the respective housings of plug 28 and receptacle 26 may be shaped to provide for increased durability of assembly 20, especially when plug 28 and receptacle 26 are connected to one another. For example, the respective housings of plug 28 and receptacle 26 may be configured to engage each other in a tongue and groove manner to increase the durability of electrical connection

assembly 20 and reduce the load placed on electrical connectors of plug 28 and receptacle 26 resulting from external forces, especially when mated to electrically couple cable 22 to defibrillator 12.

[0040] Furthermore, in some examples, the respective housing of plug 28 and receptacle 26 may define an internal space which may house electrical components which are connected to the respective electrical connectors. For example, the housing of plug 28 may define an internal space which contains one or more high voltage electrical components of cable 22 which directly connect to the corresponding electrical connector of plug 28. In such cases, the plug housing may be configured to provide a barrier between high voltage components within the internal space and the remainder of plug 28. In such a manner, a user handling plug 28 may be electrically isolated from the high voltage components and, thus, may safely handle plug 28 despite the content of the high voltage components.

[0041] Still referring to FIG. 2, interface 24 includes a switch (not shown in FIG. 2) that, when activated, couples an energy storage circuit 30 to electrodes 18 via one or more conductors contained in leads 16 and cable 22. Energy storage circuit 30 stores the energy to be delivered to patient 14 in the form of a defibrillation pulse. The switch may be of conventional design and may be formed, for example, of electrically operated relays. Alternatively, the switch may comprise an arrangement of solid-state devices such as silicon-controlled rectifiers or insulated gate bipolar transistors. Energy storage circuit 30 of FIG. 2 is one example of an energy storage device within the housing of defibrillator 12 that stores electrical energy for delivery to patient 12.

[0042] Energy storage circuit 30 includes components, such as one or more capacitors, that store the energy to be delivered to patient 14 via electrodes 18. In some examples, before a defibrillation pulse may be delivered to patient 14, energy storage circuit 30 must be charged. Processor 32 directs a charging circuit 34 to charge energy storage circuit 30 to a high voltage level. Charging circuit 34 comprises, for example, a flyback charger that transfers energy from a power source 36 to energy storage circuit 30.

[0043] Defibrillator 12 may be a manual defibrillator or an automated external defibrillator (AED). Where defibrillator 12 is a manual defibrillator, a caregiver

using defibrillator 12 may select an energy level for each defibrillation pulse delivered to patient 14. Processor 32 may receive the selection made by the caregiver via a user interface 38, which may include input devices, such as a keypad and various buttons or dials, and output devices, such as various indicator lights, a cathode ray tube (CRT), light emitting diode (LED), or liquid crystal display (LCD) screen, and a speaker. Where defibrillator 12 is an AED, processor 32 may select an energy level from a preprogrammed progression of energy levels stored in memory 40 based on the number of defibrillation pulses already delivered to patient 14.

**[0044]** Although user interface 38 of FIG. 2 is shown as a feature on or within defibrillator 12, example system 10 may additionally, or alternatively, include user interface 38 at a location other than that of defibrillator 12. For example, in examples which electrodes 18 are included in paddles, user interface 38 may be extended to one or more of the paddles, e.g., in the form of buttons, dials, and indicators that may allow setting of one or more parameters such as energy level, charge initiation, shock delivery as well as printer control. In such examples, the controls of user interface 38 may connect to defibrillator 12 via one or more control lines in cable 22.

**[0045]** When the energy stored in energy storage circuit 30 reaches the desired energy level, processor 32 controls user interface 38 to provide an indication to the caregiver that defibrillator 12 is ready to deliver a defibrillation pulse to patient 14, such as an indicator light or a voice prompt. The defibrillation pulse may be delivered manually or automatically. Where the defibrillation pulse is delivered manually, the caregiver may direct processor 32 to deliver the defibrillation pulse via user interface 38 by, for example pressing a button. In either case, processor 32 activates the switches of interface 24 to electrically connect energy storage circuit 30 to electrodes 18 through electrical connection assembly 20, and thereby deliver the defibrillation pulse to patient 14.

**[0046]** Processor 32 may modulate the defibrillation pulse delivered to patient 14. Processor 32 may, for example, control the switches of interface 24 to regulate the shape and width of the pulse. Processor 32 may control the switches to modulate

the pulse to, for example, provide a multiphasic pulse, such as a biphasic truncated exponential pulse, using one or more techniques known in the art.

[0047] Processor 32 may perform other functions as well, such as monitoring electrical activity of the heart of patient 14 sensed, e.g., via electrodes 18.

Processor 32 may determine whether the heart of patient 14 is fibrillating based upon the sensed electrical activity in order to determine whether a defibrillation pulse should be delivered to patient 14. Where a defibrillation pulse has already been delivered, processor 32 may evaluate the efficacy of the delivered defibrillation pulse by determining if the heart is still fibrillating based on the sensed electrical activity in order to determine whether an additional defibrillation pulse is warranted. Processor 32 may automatically deliver defibrillation pulses based on these determinations, or may advise the caregiver of these determinations via user interface 38. Processor 32 may display an electrocardiogram (ECG) that reflects the sensed electrical activity via user interface 38.

[0048] Processor 32 may store an indication of the time of delivery of each defibrillation pulse delivered to patient 14 as medical event information 42 within memory 40 for patient 28. Processor 32 may also store the energy level of each pulse and other characteristics of each pulse, such as the width, amplitude, or shape, as medical event information 42 for patient 14. Processor 32 may also store a digital representation of the ECG, or a heart rate over time determined based on the electrical activity of the heart of patient 14 detected via electrodes 18 as medical event information 42 for patient 14. Further, processor 32 may control delivery of other types of therapy to patient 14 via electrodes 18, such as cardioversion or pacing therapy, and store information describing the times that such therapies were delivered and parameters of such therapies, such as cardioversion pulse energy levels and pacing rates, as medical event information 42 for patient 14.

[0049] FIG. 3 is diagram illustrating an example configuration of system 10 including an example configuration of electrical connection assembly 20. As described previously with respect to FIGS. 1 and 2, system 10 includes defibrillator 12, cable 22 and electrical connection assembly 20. Electrical connection assembly 20 includes plug 28 and receptacle 26, which are shown in

FIG. 3 with plug 28 connected to receptacle 26. When plug is connected to receptacle, cable 22 is electrically and physically coupled to defibrillator 12 via electrical connection assembly 20. When cable 22 is electrically coupled to defibrillator 12, electrical stimulation generated by defibrillator 12 may be delivered via electrodes 18 on leads 16 (not shown) of cable 22. Furthermore, defibrillator 12 may also monitor one or more electrical signal of patient 14 via electrodes 18 or other sensors or transducers coupled to patient 14 when cable 22 is electrically coupled to defibrillator 12.

[0050] In the example of FIG. 3, electrical connection assembly 20 is configured such that plug 28 may be inserted into receptacle 26 by a user via a side insertion path. The insertion path of plug 28 with respect to receptacle 26 is generally indicated by arrow 44. In the example shown, receptacle 26 is fixed to or integral with an external surface 46 of defibrillator 12, and is configured to receive plug 28 along a plane that is substantially parallel to the plane of surface 46. As shown, surface 46 is a major surface of defibrillator 12. As shown in FIG. 3, receptacle connector 26 is provided on the housing of defibrillator 12 so as to define an insertion path 44. As will be described in further detail below, plug connector 28 may be aligned with the insertion path and then slid along the insertion path substantially parallel to surface 46 of defibrillator 12 for coupling to receptacle 26. When the connectors are coupled to one another in this manner, electrodes 18 FIG. 1, which terminates at plug connector 28, may deliver energy stored in the energy storage circuit 30 of defibrillator 12 to patient 14.

[0051] Such an insertion path is different from that of other defibrillation systems in which the connector, e.g., plug, at the proximal end of the cable is inserted into the defibrillator connector, e.g., receptacle, in a direction that is substantially orthogonal to the surface of the defibrillator containing the connector. This conventional insertion path may be similar to that of the insertion path of an electrical plug of an electrical appliance into a conventional wall outlet. Conversely, as illustrated by the example of FIG. 3, examples of the disclosure may include an electrical connection assembly 20 that allows plug 28 to be inserted into receptacle 26 along a path that is substantially non-orthogonal to surface 46 of defibrillator 12 containing receptacle 26. For example, as shown, the insertion

path 44 followed by plug 28 when being slid for coupling to receptacle connector 26 may be substantially parallel to surface 46 of the housing of defibrillator 12.

**[0052]** Furthermore, as illustrated in the example of FIG. 3, at least in part due to the insertion path of plug 28, electrical connection assembly 20 provides a low-profile connection of cable 22 to defibrillator 12. For example, with respect to front surface 46, rather than the proximal end of cable 22 protruding in a generally orthogonal direction relative to surface 46 when plug 28 is connected to receptacle 26, the proximal end of cable 22 follows a path that is substantially parallel to surface 46. Moreover, the shape of plug 28 and receptacle 26 is such that when plug 28 and receptacle 26 are connected, electrical connection assembly does not substantially protrude from surface 46.

**[0053]** By providing a low-profile connection, the connection between cable 22 and defibrillator 12 via assembly 20 is less likely to be damaged during use of system 10. For example, a low-profile connection may decrease the relative degree that cable 22 protrudes from surface 46 of defibrillator 12 compared, e.g., to a connection configuration in which cable 22 protrudes substantially orthogonally from the face of surface 46. As a result, electrical connection assembly 20, and cable 22 in particular, may be less likely to be subjected to impact during transport, use and/or storage of system 10. Such impact may lead to various types of damage causing, e.g., intermittent or open electrical coupling between defibrillator 12 and cable 22, or physical coupling failure between plug 28 and receptacle 26. Accordingly, the low profile configuration of assembly 20 may act to increase the reliability and/or durability of system 10 by preventing such damage to connection assembly 20.

**[0054]** The low-profile nature may not only protect cable 22 and connection assembly 20 from damage, but it may also provide protection and ease of use for a user when defibrillator is being transported, e.g., a protruding connector and/or cable may get caught on clothing, door jams, a person's body, and the like. The low-profile configuration may allow cable 22 to be directed substantially along the plane of surface 46 as opposed to being directed substantially perpendicular to the plane of surface 46, thereby allowing for easier handling of defibrillator 12 as well

as allowing for optimum soft case design for further protection and consolidation of cabling and accessories.

[0055] FIGS. 4A and 4B are perspective diagrams illustrating electrical connection assembly 20 of FIG. 3 in greater detail. In particular, FIGS. 4A and 4B illustrate electrical connection assembly 20 in disconnected and connected configurations, respectively. As previously described, electrical connection assembly 20 includes plug 28 and receptacle 26, which may be connected to one another to electrically and physically couple cable 22 to defibrillator 12. As shown in FIG. 3, receptacle connector 26 may be provided on the housing of defibrillator 12 so as to define an insertion path 44, where plug connector 28 may be aligned and then slid along the insertion path substantially parallel to the surface 46 of defibrillator for coupling to the receptacle connector 28. Housing 54 of receptacle connector 26 is shown separated from that of the remainder of defibrillator for ease of illustration.

[0056] Referring to FIG. 4A, plug 28 includes male electrical connector 48 partially exposed from plug housing 52, and receptacle 26 includes female electrical connector 50 partially exposed in receptacle housing 54. Female electrical connector 50 is electrically coupled to defibrillator 12 (not shown), and provides a connector for defibrillator 12 to be electrically coupled to another electrical device, such as cable 22. Male electrical connector 48 is electrically coupled to conductive components of cable 22 (not shown) and provides a connector for cable to be electrically coupled another electrical device. As will be described in further detail with respect to FIG. 5H, plug 28 may include an internal chassis space that is configured to electrically isolate the high voltage components contained within plug housing 54 from the non-electrical components which provide mechanical support of plug 28 and also the non-electrical components that facilitate engagement of plug 28 with receptacle 26.

[0057] By inserting plug 28 completely into receptacle 26 according to an insertion path indicated by arrow 44, male electrical connector 48 connects to female electrical connector 50. When electrical connector 48 and electrical connector 50 are connected, cable 22 may be electrically coupled to defibrillator 12. For example, when electrical connectors 48 and 50 are connected to one another, an electrical signal, e.g., a defibrillation pulse generated by defibrillator 12, may be

conducted from defibrillator 12 to leads 16 and electrodes 18 of cable 22 through electrical connectors 48 and 50.

**[0058]** Housing 54 of receptacle 26 and housing 52 of plug 28 are configured to provide for secure mechanical and electrical coupling of cable 22 to defibrillator 12. In the example shown, surfaces 56 and 62, and guidance members 58 and 60 act to define a receiving space 64 which is configured to receive all or a portion of plug 28. When connected to receptacle, all or a portion of plug 28 occupies receiving space 64. Notably, receiving space 64 helps define a path of insertion that may be characterized as a side insertion path when receptacle 26 is mounted on surface of defibrillator 12, as shown in FIG. 3.

**[0059]** Guidance members 58 and 60 and surface 62 also form part of a guidance mechanism which helps align and guide plug 28 into the proper position to connect to receptacle 26 when the appropriate portion of plug housing 52 is inserted into receiving space 64. In the example shown, guidance members 58 and 60 form the side walls of receiving space 64. Notably, guidance members 58 and 60 are configured as undercut walls which act to receive and engage wings 66 and 68 (wing 68 not shown in FIG. 4A) of housing 52 on either side of plug 28. When plug 28 is inserted into receptacle 26, wings 66 and 68 engage guidance members 58 and 60, respectively, by sliding into the undercut space defined by the guidance members 58 and 60.

**[0060]** The configuration of guidance members 58 and 60 with respect to wings 66 and 68 is such that only when male electrical connector 48 of plug 28 is substantially properly aligned with female electrical connector 50 will wings 66 and 68 initially slide into guidance members 58 and 60. Further, once wings 66 and 68 have properly engaged guidance members 58 and 60, wings 66 and 68 and guidance members 58 and 60 act to prevent plug 28 becoming misaligned relative to receptacle 26 by only allowing plug 28 to be slid into receiving space 64 to connect electrical connector 48 to electrical connector 50 along a properly aligned path. Notably, when plug 28 is inserted into receptacle 26, wings 66 and 68 must first engage guidance member 58 and 60 before electrical connectors 48 and 50 may be connected to one another. In this manner, the guidance mechanism of electrical connection assembly 20 ensures that the respective electrical connectors

48 and 50 are properly aligned when connected to one another by a user, and prevents all or portions of one or both of connectors 48 and 50 from being damaged due to a user attempting to connect electrical connectors 48 and 50 to one another while misaligned. By avoiding such damage to connectors 48 and 50, the reliability and integrity of the electrical coupling of leads 16 and electrodes 18 of cable 22 to defibrillator 12 via electrical connection assembly 20 may be increased as a result of the described guidance mechanism.

**[0061]** Furthermore, to help a user initially align wings 66 and 68 into guidance members 58 and 60, surface 62 of receptacle 26 includes channels 74 and 76 which mate with corresponding runners 78 and 80 located on the bottom surface 90 (not shown) of plug 28. Runners 78 and 80 are illustrated, e.g., in FIG. 5B, and will be described in further detail below. As configured, when runners 78 and 80 sit in channels 74 and 76, respectively, wings 66 and 68 are properly aligned to be inserted into guidance member 58 and 60. In this manner, a user may more easily slide plug 28 into receptacle 26 to provide a connected electrical assembly 20.

**[0062]** It is recognized that other alignment features similar to those described may provide the same or similar functions even in different configurations with respect to plug 28 and receptacle 26. For example, although wings 66 and 68 and guidance members 58 and 60 are shown in FIG. 4A on the sides of plug 28 and receptacle 26, respectively, in some cases, the same or similar features may be provided on different portions of plug 28 and receptacle 26, while still providing substantially the same function. As one example, receptacle 26 may include one or more alignment channels formed into surface 62 of receptacle 26 that receive corresponding members protruding from bottom surface 90 of plug 28 to properly align electrical connectors 48 and 50 before they are inserted into one another by a user. Similarly, rather than including channels 74 and 76 in surface 62 of receptacle 26 and runners 78 and 80 on bottom surface 90 of plug 28, in some examples, one or more channels may be provided in bottom surface 90 of plug 28 to received one or more runners provided on surface 62 of receptacle 26, e.g., to align wings 66 and 68 with guidance members 58 and 60.

**[0063]** Furthermore, while receptacle 26 and plug 28 are shown to include two channels and runners, respectively, any suitable number of such features may be

used. For example, in some cases, receptacle 26 and plug 28 may include a single channel and a single runner, respectively. In each case, the insertion path may include one or more runners and/or channels that may receive matingly to one or more runners and/or channels of plug connector 28 when aligned and slid along the insertion path. In one example, the insertion path includes at least one channel in the housing, and the first connector (e.g., plug 28) includes at least one runner that can be received matingly in the channel while the first connector is being slid along the insertion path. In another example, the insertion path includes at least one runner in the housing, and the first connector (e.g., plug 28) includes at least one channel that can receive matingly the runner while the first connector is being slid along the insertion path. In another example, the insertion path includes two channels in the housing, and the first connector (e.g., plug 28) includes two runners that can be received matingly in the runners while the first connector is being slid along the insertion path.

**[0064]** Plug housing 52 and receptacle housing 54 may be formed of any suitable material. In some cases, housings 52 and 54 may include material which exhibit relatively low electrical conductivity, especially in examples in which the housing defines an internal chassis space to contained high voltage electrical components.

**[0065]** In some examples, all or a portion of plug housing 52 and receptacle housing 54 may include components which act to mechanically reinforce all or portion of the respective housing. For example, guidance members 58 and 60, and/or wings 66 and 68 may include one or more sheet metal reinforcement structures to increase the mechanical strength of the respective components to provide for increased durability of electrical connection assembly 20 when plug 28 is connected to receptacle 26.

**[0066]** Still referring to FIG. 4A, electrical connection assembly 20 includes a locking mechanism which securely connects plug 28 in receptacle 26 when electrical connectors 48 and 50 are properly connected to one another. As part of the locking mechanism in example assembly 20, latch aperture 70 is formed in receptacle housing 54 as part of or proximate to receiving space 64. When plug 28 is inserted into receiving space 64 as previously described, latch aperture 70 engages latch protrusion 82 (not shown in FIG. 4A), which is sized appropriately to

sit within all or a portion of latch aperture 70 when electrical connectors 48 and 50 are properly connected, to secure plug 28 to receptacle 26. As such, the sliding of plug 28 into receiving space 64 of receptacle 26 along the insertion path cause the locking mechanism to lock plug 28 to receptacle 26, as described in this disclosure.

**[0067]** As will be described in further detail below (e.g., with reference to FIG. 5F), latch protrusion 82 is provided as part of a spring-loaded latch member in plug 28. In addition to latch protrusion 82, the spring-loaded latch member includes release button 72, which is mechanically coupled to latch bolt 94 at one end, while latch protrusion 82 is coupled to latch bolt 94 at the other end.

**[0068]** To engage latch protrusion 82 with latch aperture 70 such that plug 28 is secured to receptacle 26, while plug 28 is inserted into receptacle 26, latch protrusion 82 slides into the outer portion of latch aperture 70. As latch protrusion 82 slide further into latch aperture 82, ramped surfaces 71A and 71B (ramped surface 71B not shown in FIG. 4A) of receptacle housing 54 proximate to latch aperture 70 acts on latch protrusion 82 to extend protrusion 82 relative to bottom surface 90 of plug 28. Ramped surfaces 71A and 71B continue to extend protrusion 82 until protrusion 82 no longer is in contact with ramped surface 71A and 71B due to the further insertion of plug 28 into receptacle 26. At that time, latch protrusion 82 retracts relative to bottom surface 90 of plug 28 to engage a similarly shaped portion of latch aperture 70 due to the spring loaded action of the spring loaded latch member. This engagement corresponds with the proper connection of electrical connectors 48 and 50 to one another. The process of engagement between latch protrusion 82 and latch aperture 80 is further described with respect to FIGS. 7A-7D, which illustrates cross-section views of plug 28 and receptacle 26 being connected to one another.

**[0069]** When latch protrusion 82 is engaged in the corresponding portion of latch aperture 70 as described, plug 28 is substantially prevented from moving relative to receptacle 26 and the connection between electrical connectors 48 and 50 is substantially secure. In other words, plug 28 is locked to receptacle 26. To disengage latch protrusion 82 from latch aperture 70, button 72 may be depressed, e.g., by a user, which causes latch protrusion 82 to extend relative to bottom surface 90 of plug 28. When latch protrusion 82 is in an extended position, latch

protrusion 82 is not prevented from being removed from latch aperture 70, allowing plug 28 to be disconnected from receptacle by sliding plug 28 relative to receptacle 26 in a direction substantially opposite to that which plug 28 was inserted into receptacle 26. By disengaging latch protrusion 82 from latch aperture 70, plug 28 is unlocked from receptacle 26. After being unlocked from one another, a user may uncouple plug 28 from receptacle 26 by sliding plug 28 in the opposite direction along insertion 44 that was used to couple plug 28 to receptacle 26. In this manner, a user may quickly and/or easily disconnect plug 28 from receptacle 26 despite the secure connection of plug 28 to receptacle resulting from the described locking mechanism.

**[0070]** Referring to FIG. 4B, plug 28 is shown fully connected to receptacle 26. As previously described, when connected, portion of plug 28 occupies the receiving space 64 and the described locking mechanism secures plug 28 to receptacle 26 when electrical connectors 48 and 50 are connected.

**[0071]** As shown, guidance members 58 and 60 (guidance member 85 not shown in FIG. 4B) are engaged with wings 66 and 68 (wing 68 not shown in FIG. 4B) of plug housing 52. In addition to providing for alignment of electrical connectors 48 and 50, the configuration of guidance members 58 and 60 with respect to wings 66 and 68 may improve the mechanical durability of assembly 20. For example, when wings 66 and 68 and guidance members 58 and 60 are engaged while plug 28 and receptacle 26 are connected to one another, the mechanical load that housings 54 and 56 are able to withstand may be increased. Along the same lines, such a configuration reduces the load on electrical connectors 48 and 50 from an externally applied force. In particular, when electrical connectors 48 and 50 include mated conductive pins and recesses, the additional mechanical support that wings 66 and 68 and guidance members 58 and 60 provide may prevent one or more of the conductive pins from bending and/or breaking as a result of the application of an external force, such as any force not parallel to the axis of insertion and removal of plug 28 into and from receptacle. Such a load may be applied to and accepted by housings 52 and 54 through wings 66 and 68 and guidance members 58 and 60 rather than electrical connectors 48 and 50.

[0072] As shown in FIG. 4B, the overall geometrical shape of electrical connection assembly 20 when plug 28 and receptacle 26 are connected provides for a low-profile configuration. The low profile configuration may reduce the amount of mechanical load on assembly 20. For example, in such a configuration, a low-profile connection may reduce the physical protrusion of electrical connector 20 from the surface of defibrillator 12 compared to other connection assemblies, thereby minimizing undesirable external contact with connection assembly 20 during transport, use and/or storage that may damage electrical connection assembly 20. Furthermore, the low profile of connection assembly 20 may reduce the magnitude of forces applied to connection assembly 20 in the event of external contact by reducing the moment arm of such forces. In example examples, connection assembly 20 may protrude from about 10 mm to about 50 mm above surface 46 (FIG. 3) of defibrillator 12. In some examples, connection assembly 20 may protrude from about 20 mm to about 35 mm above surface 46 (FIG. 3) of defibrillator 12. However, the protrusion height of connection assembly 20 is not limited to the recited example ranges.

[0073] As previously described, the locking mechanism of assembly 20 acts to secure plug 28 to receptacle 26 when electrical connectors 48 and 50 are properly connected, such as in the configuration shown in FIG. 4B. To disconnect plug 28 from receptacle 26, plug 28 may be moved relative to receptacle 26 in a direction generally represent by arrow 84 while button 72 is depressed to disengage latch protrusion 82 from latch aperture 70, as previously described.

[0074] FIGS. 5A-5H are diagrams illustrating example male connector plug 28 of example electrical connection assembly 20 from various views. Previously described features are commonly numbered.

[0075] With reference to FIG. 5A, plug 28 of electrical connection assembly 20 is illustrated. As shown, wing 68 is provided on a side of the plug 28, similar to that of wing 66 shown, e.g., in FIG. 4A. As previously described, wing 68 is configured to engage guidance member 58 when plug 28 is properly inserted into receptacle 26. Further, wing 68, in combination with guidance member 58, may increase the durability of electrical connection assembly when plug 28 and receptacle 26 are connected to one another.

[0076] Plug 28 also includes ribbed surfaces 86A and 86B provided on the exterior surface of housing 52. Ribbed surface 86A and 86B provide an area for a user to securely grip plug, e.g., when they are connecting or disconnecting plug 28 from receptacle 26. Plug 28 also includes grip protrusion 88 which serves to allow a user to more easily disconnect plug 28 from receptacle 26. For example, if a user grips plug 28 at ribbed surfaces 86A and 86B with a thumb and middle finger, respectively, then in some example, the users may more easily disconnect plug 28 by allowing their little finger or another finger to engage grip protrusion 88 to prevent their hand from slipping down cable 22.

[0077] With reference to FIG. 5B, bottom surface 90 of plug 28 includes runners 78 and 80, and latch protrusion 82. Runner 78 and 80 are configured to engage channels 74 and 76, respectively, as previously described. Latch protrusion 82 is configured to engage latch aperture 70 as previously described.

[0078] Latch protrusion 82 includes flanged circumference 92 to allow ramped surfaces 71A and 71B to act on latch protrusion 82 so that latch protrusion 82 is extended relative to bottom surface 90 of plug 28 when plug 28 is being inserted into receptacle 26. Flanged circumference 92 of latching protrusion is also illustrated in FIGS. 5D, 5F and 5G.

[0079] With reference to FIG. 5F, plug 28 is illustrated from a cross-sectional view along line A-A shown in FIG. 5C. Notably, the cross-section view illustrates various components of spring-loaded latch member 91 that was previously described. Spring-loaded latch member 91 includes latch bolt 94, button 72, latch protrusion 82, and spring 96. Button 72 is coupled to one end of latch bolt 94 and latch protrusion 82 is coupled at the opposite end of latch bolt 94 via screw 98. Spring 94 surrounds latch bolt 96, and is configured such that latch member 91 is spring-loaded, as previously described. As configured, button 72 may be depressed to extend latch protrusion 82 relative to bottom surface 90 of plug housing 52.

[0080] As also shown in FIG. 5F, plug 28 includes internal chassis space 100, defined in part by housing 52, which may include high voltage components of cable 22, such as, e.g., portions of leads 16, which are directly connected to electrical connector 48. In general, plug housing 52 is configured to provide a

barrier between high voltage components within space 100 and remainder of plug 28, such that a user handling plug 28 and/or depressing button 72 is electrically separated from the high voltage components and, thus, may safely handle plug 28 despite the content of the high voltage components. As can be seen in FIG. 5F, spring-loaded latch member 91 extends through chassis space 100, but is electrically isolated from such high voltage components, which may be positioned within chassis space 100 around the latch member.

**[0081]** FIG. 5G is a front view diagram illustrating plug 28. As shown, in the illustrated example, electrical connector 48 is a 13-pin connector, although in other examples, connector 48 and corresponding connector 50 in receptacle 26 may include other appropriate types of electrical connectors.

**[0082]** FIG. 5H is a diagram illustrating various components of plug 28 in a disassembled state.

**[0083]** FIGS. 6A-6H are diagrams illustrating female receptacle 28 of example electrical connection assembly 20 from various views. As shown, ramped surface 71B is provided proximate to latch aperture 70 and is substantially the same or similar to that of ramped surface 71A shown in FIG. 4A. As configured, ramped surfaces 71A and 71B act on latch protrusion 82 to extend protrusion 82 relative to bottom surface 92 when latch protrusion 82 is slid into latch aperture 70, as previously described.

**[0084]** Receptacle 26 also includes fastener apertures 102A-D which provides a structure for receptacle to be fixed to surface 46 of defibrillator 12 via one or more fasteners. For example, a screw may be inserted into each of apertures 102A-D and screwed into a receiving space on defibrillator 12 to securely affix receptacle 26 to surface 46, as shown in FIG. 3.

**[0085]** The height 101 of fastener 20 above surface 46 of defibrillator 12 is illustrated in FIG. 6D with reference to receptacle 26. As discussed above, height 101 may range from about 10 mm to about 50 mm above surface 46 (FIG. 3) of defibrillator 12, or from about 20 mm to about 35 mm above surface 46 (FIG. 3) of defibrillator 12, as examples.

[0086] With reference to FIG. 6G, receptacle 26 is illustrated from a cross-sectional view along line B-B shown in FIG. 6F. In particular, FIG. 6G illustrates the undercut configuration of guidance member 58 and 60 as previously described.

[0087] FIG. 6H is a diagram illustrating various components of receptacle 26 in a disassembled state. As shown, in the illustrated example, electrical connector 50 is configured to receive 13-pin connector 48. Receptacle housing 54 defines inner receptacle space 104 which may contain one or more electrical connectors that are connected to electrical components within a housing of defibrillator 12.

[0088] FIGS. 7A-7D are cross-sectional diagrams illustrating the connection of example male connector plug 28 to a female receptacle connector 26 of electrical connection assembly 20. In particular, receptacle 26 and plug 28 are illustrated from a cross-sectional view substantially along lines C-C and D-D shown FIGS. 6C and 5C, respectively. FIGS. 7A-7D progressively show plug 28 being inserted into receptacle 26 according to a side-insertion path, as previously described.

[0089] As indicated by FIGS. 7A-7D, as latching protrusion 82 is inserted into latching aperture 70, ramped surfaces 71A and 71B of receptacle housing 54 proximate to latch aperture 70 acts on latch protrusion 82 to extend protrusion 82 relative to bottom surface 90 of plug 28. Ramped surfaces 71A and 71B continue to extend protrusion 82 until protrusion 82 no longer is in contact with ramped surface 71A and 71B due to the further insertion of plug 28 into receptacle 26. At that time, latch protrusion 82 retracts relative to bottom surface 90 of plug 28 to engage a similarly shaped portion of latch aperture 70 due to the action of spring 96 on latch bolt 94. This engagement corresponds with the proper connection of electrical connectors 48 and 50 to one another, as indicated by position of connectors 48 and 50, and latch protrusion 82 in FIG. 7D.

[0090] As previously described, when latch protrusion 82 is engaged in the corresponding portion of latch aperture 70 as described, plug 28 is prevented from moving relative to receptacle 26 and the connection between electrical connectors 48 and 50 is secure. To disengage latch protrusion 82 from latch aperture 70, button 72 may be depressed, e.g., by a user, which causes latch protrusion 82 to extend relative to bottom surface 90 of plug 28. When disengaged, plug 28 may be disconnected from receptacle 26. In this manner, a user may quickly and easily

disconnect plug 28 from receptacle 26 despite the secure connection of plug 28 to receptacle 26 resulting from the described locking mechanism.

**[0091]** FIGS. 8A and 8B are diagrams illustrating another example electrical connection assembly 106. In particular, FIG. 8A illustrates electrical connection assembly 106 in a disconnected configuration, and FIG. 8B illustrates a cross-sectional view of electrical connection assembly in a connected configuration.

**[0092]** Electrical connection assembly 106 includes plug 108 and receptacle 110. Plug 108 and receptacle 110 are similar to plug 28 and receptacle 26 of electrical connection assembly 20 as previously described. However, as shown, electrical connection assembly 106 contains a locking mechanism different from that of electrical connection assembly 20. As shown, receptacle 110 includes molded ramp 112 on the bottom surface 114 of receiving space 116, rather than latching aperture 70. When plug 108 is inserted into receiving space 116, molded ramp 112 depresses until channel 118 provided in bottom surface of plug 108 allows ramp 112 to retract to its normal position, thereby engaging a corresponding wall of channel 118 to prevent plug 108 from being disconnected from receptacle 110. In this manner, the locking mechanism of electrical assembly 106 may secure connection of plug 108 to receptacle 110.

**[0093]** As configured, button 120 may be depressed to cause bolt 122 to depress ramp 112, thereby disengaging ramp 112 from the wall of channel 118.

Accordingly, plug 108 may be disconnected from receptacle 110 by sliding plug 108 relative to receptacle 110 along a path substantially opposite to that of the insertion path, when button 120 is suitably depressed. In this manner, a user may quickly and easily disconnect plug 108 from receptacle 110 despite the secure connection of plug 108 to receptacle 110 resulting from the described locking mechanism.

**[0094]** FIGS. 9A and 9B are diagrams illustrating an example electrical connection assembly 124 including plug 126 and receptacle 128. Plug 126 and receptacle 128 are similar to plug 28 and receptacle 26 of electrical connection assembly 20 as previously described. However, as shown, electrical connection assembly 124 contains a locking mechanism different from that of electrical connection assembly 20. As shown, plug 126 includes rotatable member 127 which mates with an

internal latch (not shown) contained within plug 126. When plug 126 is connected to receptacle 128, rotatable member 127 may be rotated an appropriate amount to engage the internal latch with receptacle 128. When in the engaged configuration, plug 126 is prevented from being disconnected from receptacle 128. In this manner, the locking mechanism of electrical assembly 124 may secure connection of plug 126 to receptacle 128.

[0095] As configured, the internal latch may be disengaged from receptacle 128 by rotating rotatable member 127 an appropriate amount. In some cases, the design of rotatable member 127 may indicate whether electrical connection assembly is in a locked or unlocked position. When disengaged, plug 126 may be disconnected from receptacle 128 by sliding plug 126 relative to receptacle 128 along a path substantially opposite to that of the insertion path. In this manner, a user may be able to quickly and easily disconnect plug 126 from receptacle 128 despite the secure connection of plug 126 to receptacle 128 resulting from the described locking mechanism.

[0096] FIGS. 10A and 10B are diagrams illustrating an example electrical connection assembly 130. In particular, FIG. 10A illustrates electrical connection assembly 130 in a connected configuration, and FIG. 10B illustrates a disassembled view of electrical connection assembly 130.

[0097] Electrical connection assembly 130 includes plug 132 and receptacle 134. Plug 132 and receptacle 134 are similar to plug 28 and receptacle 26 of electrical connection assembly 20 as previously described. However, as shown, electrical connection assembly 130 contains a locking mechanism different from that of electrical connection assembly 20. As shown, receptacle 134 includes locking aperture 140 on the bottom surface 142 of receiving space 144. Plug 132 includes dial 136 coupled to one end of threaded bolt 138, and bolt aperture 139. When plug 132 is connected to receptacle 134, bolt 138 may be inserted through bolt aperture 139 into locking aperture 140, and screwed into locking aperture 140 by rotating bolt 138 using dial 13 to engage locking aperture 140. When in the engaged configuration, plug 132 is prevented from being disconnected from receptacle 134. In this manner, the locking mechanism of electrical assembly 130 may secure connection of plug 132 to receptacle 134.

[0100] As configured, bolt 138 may be disengaged from locking aperture 140 by unscrewing bolt 138 from locking aperture 140 using dial 136. When disengaged, plug 132 may be disconnected from receptacle 134 by sliding plug 132 relative to receptacle 134 along a path substantially opposite to that of the insertion path. In this manner, a user may be able to quickly and easily disconnect plug 132 from receptacle 134 despite the secure connection of plug 132 to receptacle 134 resulting from the described locking mechanism.

[0101] FIGS. 11A and 11B are diagrams illustrating an example electrical connection assembly 146. In particular, FIG. 11A illustrates electrical connection assembly 146 in a connected configuration, and FIG. 11B illustrates a disassembled view of electrical connection assembly 146.

[0102] Electrical connection assembly 146 includes plug 148 and receptacle 150. Plug 148 and receptacle 150 are similar to plug 28 and receptacle 26 of electrical connection assembly 20 as previously described. However, as shown, electrical connection assembly 146 contains a locking mechanism different from that of electrical connection assembly 20. As shown, receptacle 150 includes catch member 152 which rotates with respect to receptacle housing 153, as indicated by arrow 155. Plug 148 includes notch 154 on a portion of housing 157 that sits within receptacle 150 when plug 148 is connected to receptacle 150. When connected, catch member 152 may be rotated to engage notch 154. When in the engaged configuration, plug 148 is prevented from being disconnected from receptacle 150. In this manner, the locking mechanism of electrical assembly 146 may secure connection of plug 148 to receptacle 150.

[0103] As configured, catch member 152 may be disengaged from notch 154 by rotating catch member 152 an appropriate amount. When disengaged, plug 148 may be disconnected from receptacle 150 by sliding plug 148 relative to receptacle 150 along a path substantially opposite to that of the insertion path. In this manner, a user may be able to quickly and easily disconnect plug 148 from receptacle 150 despite the secure connection of plug 148 to receptacle 150 resulting from the described locking mechanism.

[0104] FIGS. 12A and 12B are diagrams illustrating an example electrical connection assembly 160. In particular, FIG. 12A illustrates electrical connection

assembly 160 in a connected configuration, and FIG. 12B illustrates a disassembled view of electrical connection assembly 160.

[0105] Electrical connection assembly 160 includes plug 162 and receptacle 164. Plug 162 and receptacle 164 are similar to plug 28 and receptacle 26 of electrical connection assembly 20 as previously described. However, as shown, electrical connection assembly 160 contains a locking mechanism different from that of electrical connection assembly 20. As shown, plug 162 includes locking tab 166 on the top surface of the plug housing 170. Receptacle 164 includes tab notch 168 on the top surface of the receptacle housing 172. As configured, when plug 162 is connected to receptacle 164, distal end 174 of locking tab 166 may engage tab notch 168. When in the engaged configuration, plug 162 is prevented from being disconnected from receptacle 164. In this manner, the locking mechanism of electrical assembly 160 may secure connection of plug 162 to receptacle 164.

[0106] As configured, locking tab 166 may be disengaged from tab notch 168 by lifting distal end of locking tab 174 over tab notch 168. When disengaged, plug 162 may be disconnected from receptacle 164 by sliding plug 162 relative to receptacle 164 along a path substantially opposite to that of the insert path. In this manner, a user may be able to quickly and easily disconnect plug 162 from receptacle 164 despite the secure connection of plug 162 to receptacle 164 resulting from the described locking mechanism.

[0107] FIGS. 13A and 13B are diagrams illustrating an example electrical connection assembly 176. In particular, FIG. 13A illustrates electrical connection assembly 176 in a connected configuration, and FIG. 13B illustrates a disassembled view of electrical connection assembly 176.

[0108] Electrical connection assembly 176 includes plug 178 and receptacle 180. Plug 178 and receptacle 180 are similar to plug 28 and receptacle 26 of electrical connection assembly 20 as previously described. However, as shown, electrical connection assembly 176 contains a locking mechanism different from that of electrical connection assembly 20. As shown, plug 178 includes side locking tabs 184 and 186 on the side surfaces of the plug housing 182. Receptacle 180 includes tab receiving spaces 188 and 190 on face of the receptacle housing 192. As configured, when plug 178 is connected to receptacle 180, side locking tabs 184

and 186 engage tab receiving spaces 188 and 190, respectively. When in the engaged configuration, plug 178 is prevented from being disconnected from receptacle 180. In this manner, the locking mechanism of electrical assembly 176 may secure connection of plug 178 to receptacle 180.

**[0109]** As configured, side locking tabs 184 and 186 may be disengaged from tab receiving spaces 188 and 190 by depressing tabs 184 and 186 inwards to, e.g., by pinching the respective side locking tabs 184 and 186 together. When disengaged, plug 178 may be disconnected from receptacle 180 by sliding plug 178 relative to receptacle 180 along a path substantially opposite to that of the insert path. In this manner, a user may be able to quickly and easily disconnect plug 178 from receptacle 180 despite the secure connection of plug 178 to receptacle 180 resulting from the described locking mechanism.

**[0110]** Various examples have been described. However, a person of ordinary skill in the art will recognize that various modifications may be made to the described examples without departing from the scope of the claimed inventions. For example, although described primarily with reference to examples in which an electrical connector is used to connect a cable or lead with electrical stimulation and/or sensing electrodes to an external defibrillator, the invention is not so limited. In other examples, an electrical connector according to the invention may be used to connect a cable or lead or any implanted or external medical device. Furthermore, in some examples, the cable or lead may include any number of electrodes, and may include other sensors in addition to or instead of electrodes. For example, the cable or lead may additionally or alternatively include any optical, capacitive, resistive, impedance, chemical, or other sensor or transducer for sensing blood oxygen saturation, blood pressure, respiration, the amount of oxygen or carbon dioxide in the air inhaled or exhaled by the patient.

**[0111]** Furthermore, although in examples described herein the electrical contacts for the connector assemblies described are generally in-line with the engagement direction of the mated direction, examples are not so limited. For example, in some examples, the electrical contacts may be wiping contacts that are substantially perpendicular to the mating direction of the respective housing. Additionally, in some examples, there may be a combination of different types of

electrical contacts in an electrical assembly. For example, in some examples, an electrical assembly may include a combination of in-line and perpendicular electrical contacts. Such a configuration may provide added isolation of high voltage/current contacts within the electrical assembly.

**CLAIMS:**

1. An external defibrillator for delivering stored electrical energy to a patient via electrodes that terminate in a first connector that can be coupled to the external defibrillator, comprising:

a housing;

an energy storage device within the housing for storing the electrical energy; and

a second connector provided on the housing so as to define an insertion path,

in which the first connector can be aligned with the insertion path, and slid along the insertion path substantially parallel to an outer surface of the housing on which the second connector is provided for coupling to the second connector.

2. The external defibrillator of claim 1, in which a locking mechanism locks the first connector to the second connector when connected to each other.

3. The external defibrillator of claim 2, in which the locking mechanism comprises a latch protrusion coupled to the first connector and a latch aperture formed in a housing of the second connector, the latch protrusion configured to engage the latch aperture such that the first connector is secured to the second connector when the first connector is properly connected to the second connector.

4. The external defibrillator of claim 2, in which a release mechanism allows a user to disengage the locking mechanism so that the first connector may be disconnected from the second connector.

5. The external defibrillator of claim 4, in which the release mechanism includes a button that may be depressed to disengage the locking mechanism.

6. The external defibrillator of claim 1, in which a guidance mechanism aligns a first electrical connector of the first connector with a second electrical connector of the second connector when the first connector is inserted into the second connector.
7. The external defibrillator of claim 1, in which a housing of the first connector defines an internal chassis space that contains high voltage electrical components, the housing providing an electrical barrier from the high voltage electrical components.
8. The external defibrillator of claim 1, in which the insertion path includes at least one channel in the housing, and the first connector includes at least one runner that can be received matingly in the channel while the first connector is being slid along the insertion path.
9. The external defibrillator of claim 1, in which the insertion path includes at least one runner in the housing, and the first connector includes at least one channel that can receive matingly the runner while the first connector is being slid along the insertion path.
10. The external defibrillator of claim 1, in which the insertion path includes two channels in the housing, and the first connector includes two runners that can be received matingly in the runners while the first connector is being slid along the insertion path.
11. The external defibrillator of claim 1, in which one of the first and the second electrical connectors includes a male plug connector and the other of the first and the second electrical connectors includes a female receptacle connector.

12. A method for coupling to an external defibrillator electrodes that terminate in a first electrical connector, the external defibrillator including a housing, an energy storage device within the housing for storing electrical energy, and a second electrical connector provided on the housing so as to define an insertion path, the method comprising:

aligning the first connector with the insertion path; and

then sliding the first connector along the insertion path substantially parallel to an outer surface of the housing on which the second connector is provided until the first connector becomes coupled with the second connector, for ultimately delivering the stored electrical energy to a patient via the electrodes.

13. The method of claim 12, in which sliding causes locking of the first connector to the second connector.

14. The method of claim 13, in which locking is performed by a latch protrusion coupled to the first connector becoming extended by the first connector being slid along the insertion path, then released into a latch aperture formed in a housing of the second connector when the first connector is properly connected to the second connector.

15. The method of claim 13, further comprising:  
unlocking the first connector from the second connector; and  
uncoupling the first connector from the second connector by at least sliding the first connector in an opposite direction along the insertion path.

16. The method of claim 15, in which unlocking is performed by a user depressing a button on the first connector to disengage the locking mechanism.

17. The method of claim 12, in which aligning the first connector with the insertion path includes inserting the first connector in a guidance mechanism configured to align the first connector with the insertion path.

18. An electrode assembly for delivering stored electrode energy to a patient from an external defibrillator that includes a second connector that can be coupled to the electrode assembly, in which the second connector is provided on a housing of the external defibrillator so as to define an insertion path, the electrode assembly comprising:

an electrical cable;

a first connector coupled to the cable; and

at least one electrode that terminates in the first connector,

in which the first connector can be aligned with the insertion path defined by the second electrical connector, and slid along the insertion path substantially parallel to an outer surface of the housing of the external defibrillator for coupling to the second connector.

19. The electrode assembly of claim 18, further comprising a locking mechanism, in which the locking mechanism locks the first connector to the second connector when connected to each other.

20. The electrode assembly of claim 19, further comprising a latch protrusion of the locking mechanism coupled to the first connector, in which the locking mechanism further comprises a latch aperture formed in a housing of the second connector, the latch protrusion configured to engage the latch aperture such that the first connector is secured to the second connector when the first connector is properly connected to the second connector.

21. The electrode assembly of claim 19, further comprising a release mechanism of the locking mechanism coupled to the first connector, in which the release mechanism allows a user to disengage the locking mechanism so that the first connector may be disconnected from the second connector.

22. The electrode assembly of claim 21, in which the release mechanism includes a button that may be depressed to disengage the locking mechanism.

23. The electrode assembly of claim 18, further comprising a guidance mechanism, in which the guidance mechanism aligns a first electrical connector of the first connector with a second electrical connector of the second connector when the first connector is inserted into the second connector.

24. The electrode assembly of claim 18, in which a housing of the first connector defines an internal chassis space that contains high voltage electrical components, the housing providing an electrical barrier from the high voltage electrical components.

25. The electrode assembly of claim 18, in which  
the insertion path includes at least one channel in the housing of the defibrillator housing, and  
the first connector includes at least one runner that can be received matingly in the channel while the first connector is being slid.

26. The electrode assembly of claim 18, in which  
the insertion path includes at least one runner in the housing, and  
the first connector includes at least one channel that can receive matingly the runner while the first connector is being slid.

27. The electrode assembly of claim 18, in which  
the insertion path includes two channels in the housing, and  
the first connector includes two runners that can be received matingly in the runners while the first connector is being slid.

28. The electrode assembly of claim 18, in which one of the first and the second electrical connectors includes a male plug connector and the other of the first and the second electrical connectors includes a female receptacle connector.

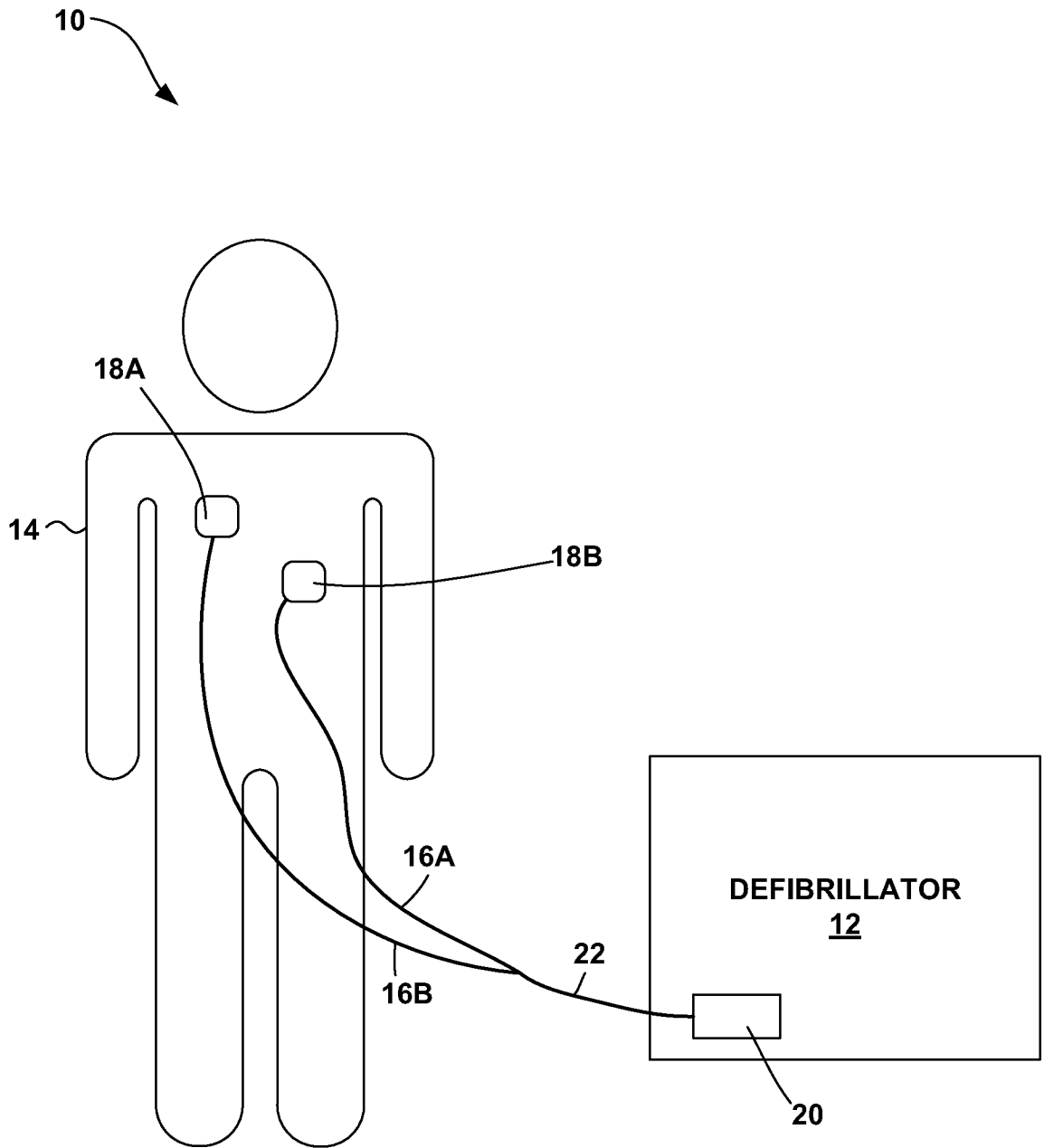


FIG. 1

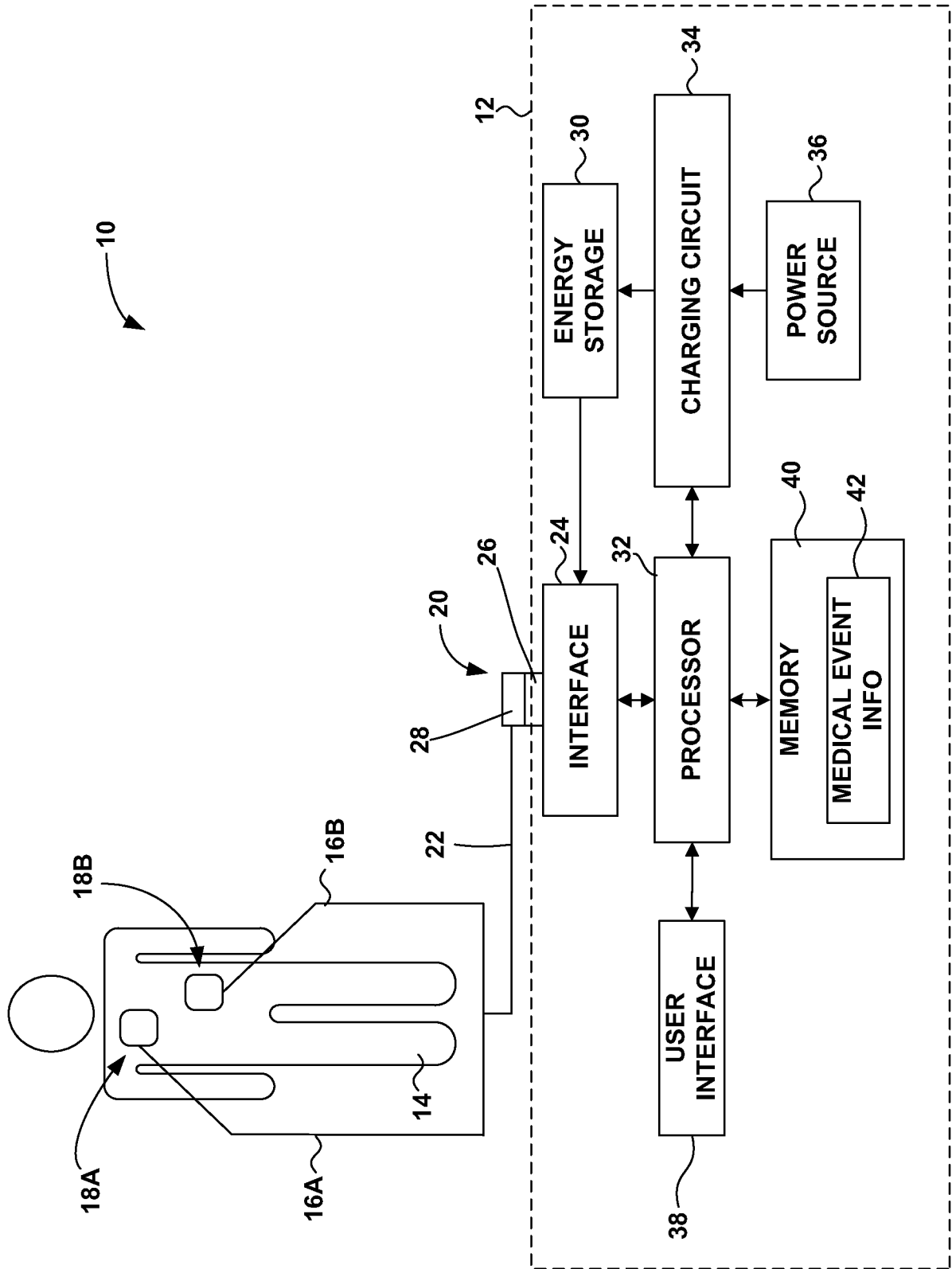


FIG. 2

10

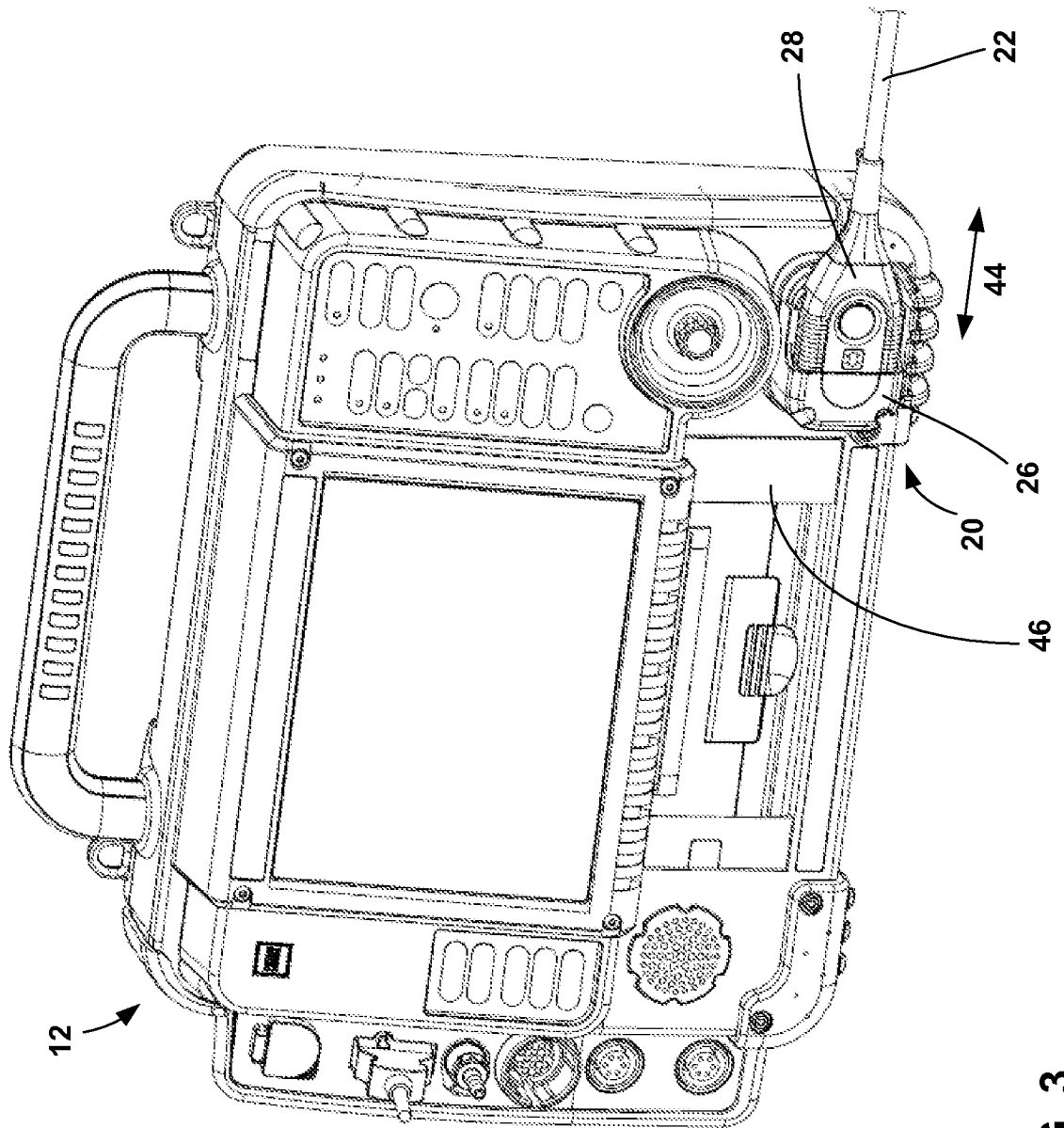


FIG. 3



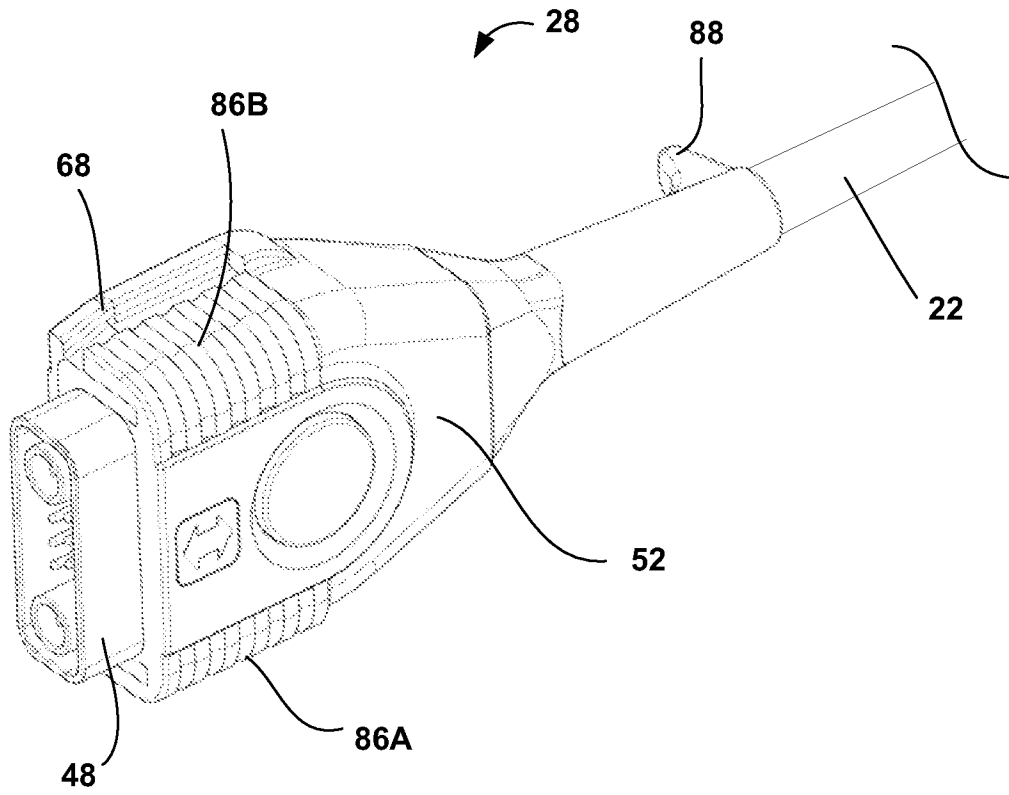


FIG. 5A

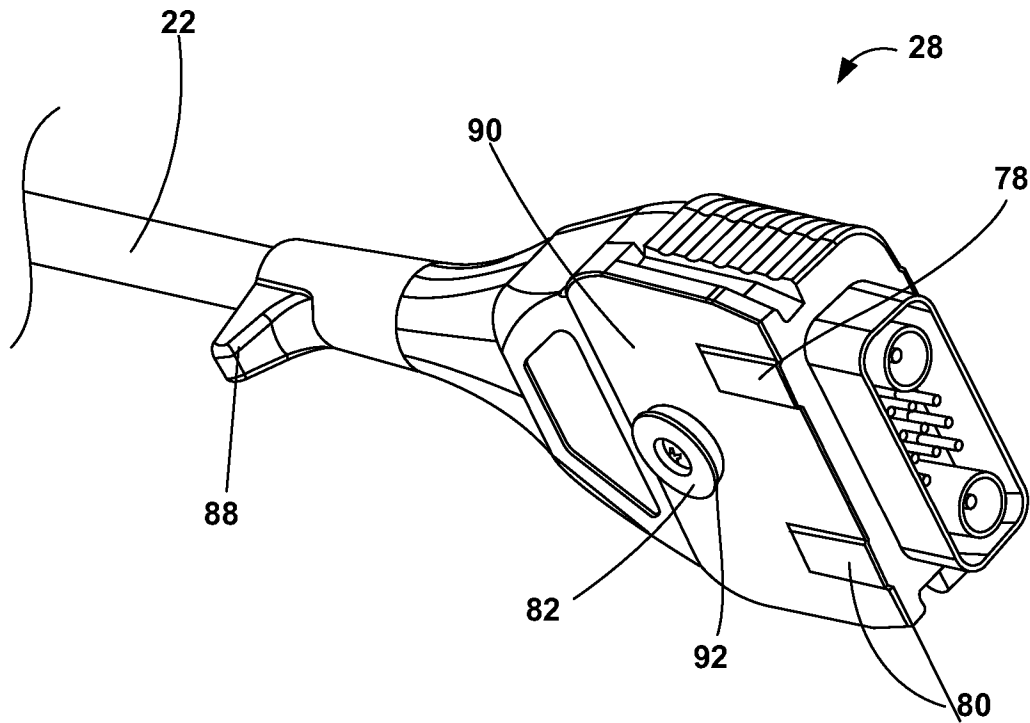


FIG. 5B

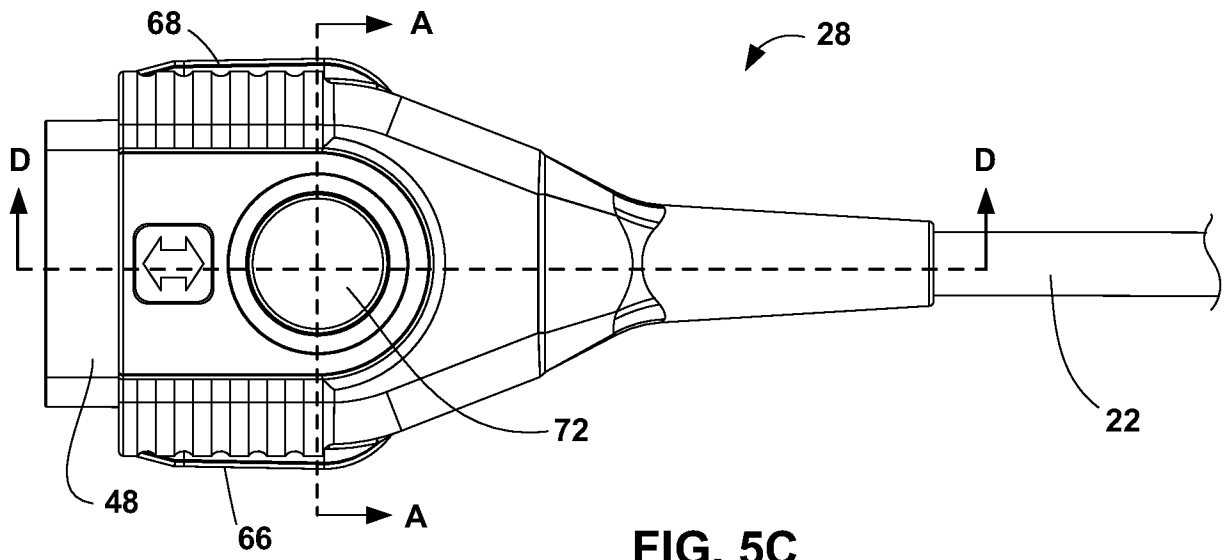


FIG. 5C

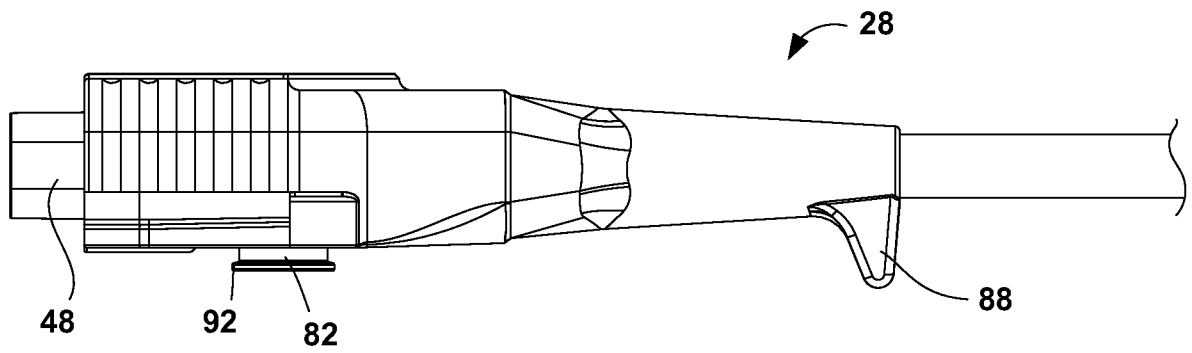


FIG. 5D

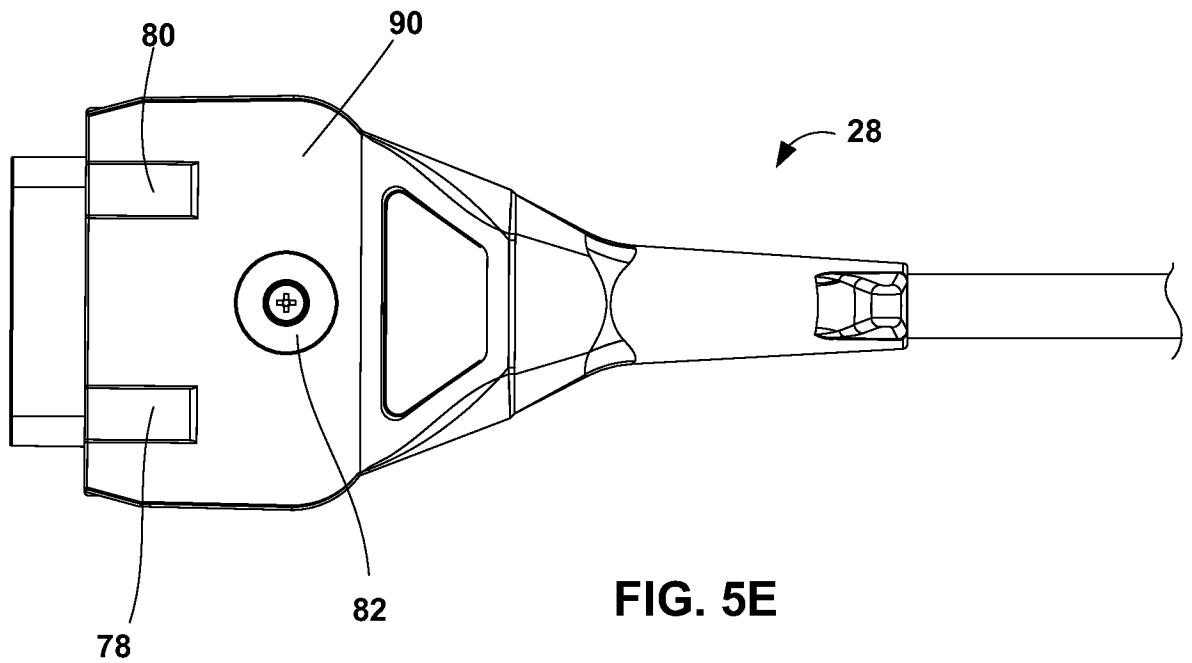


FIG. 5E

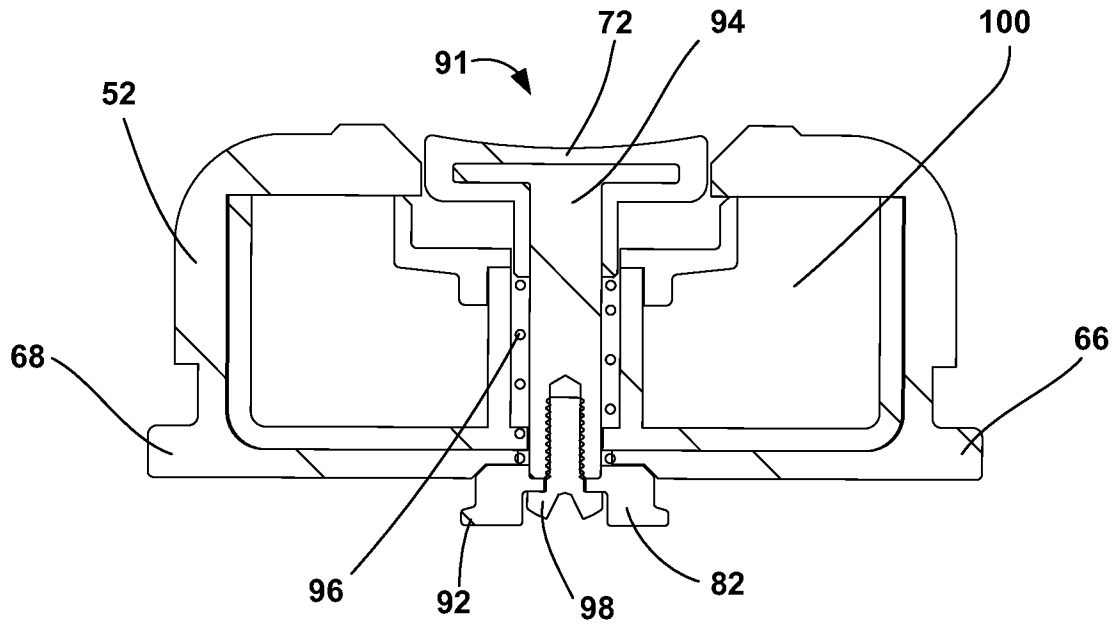


FIG. 5F

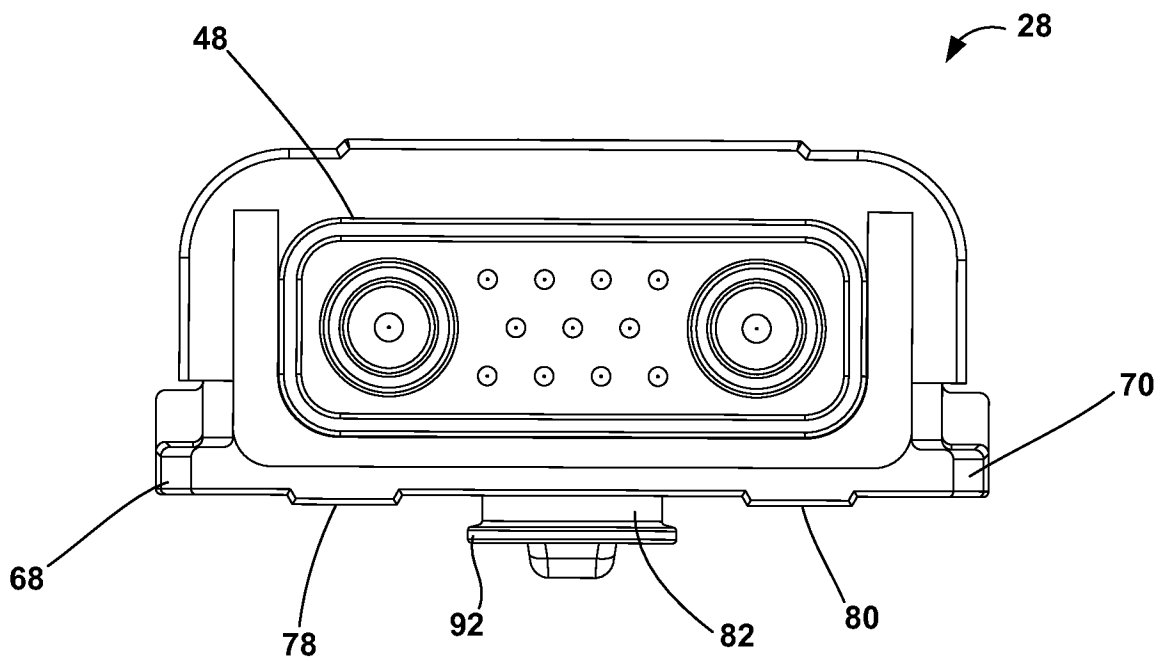


FIG. 5G

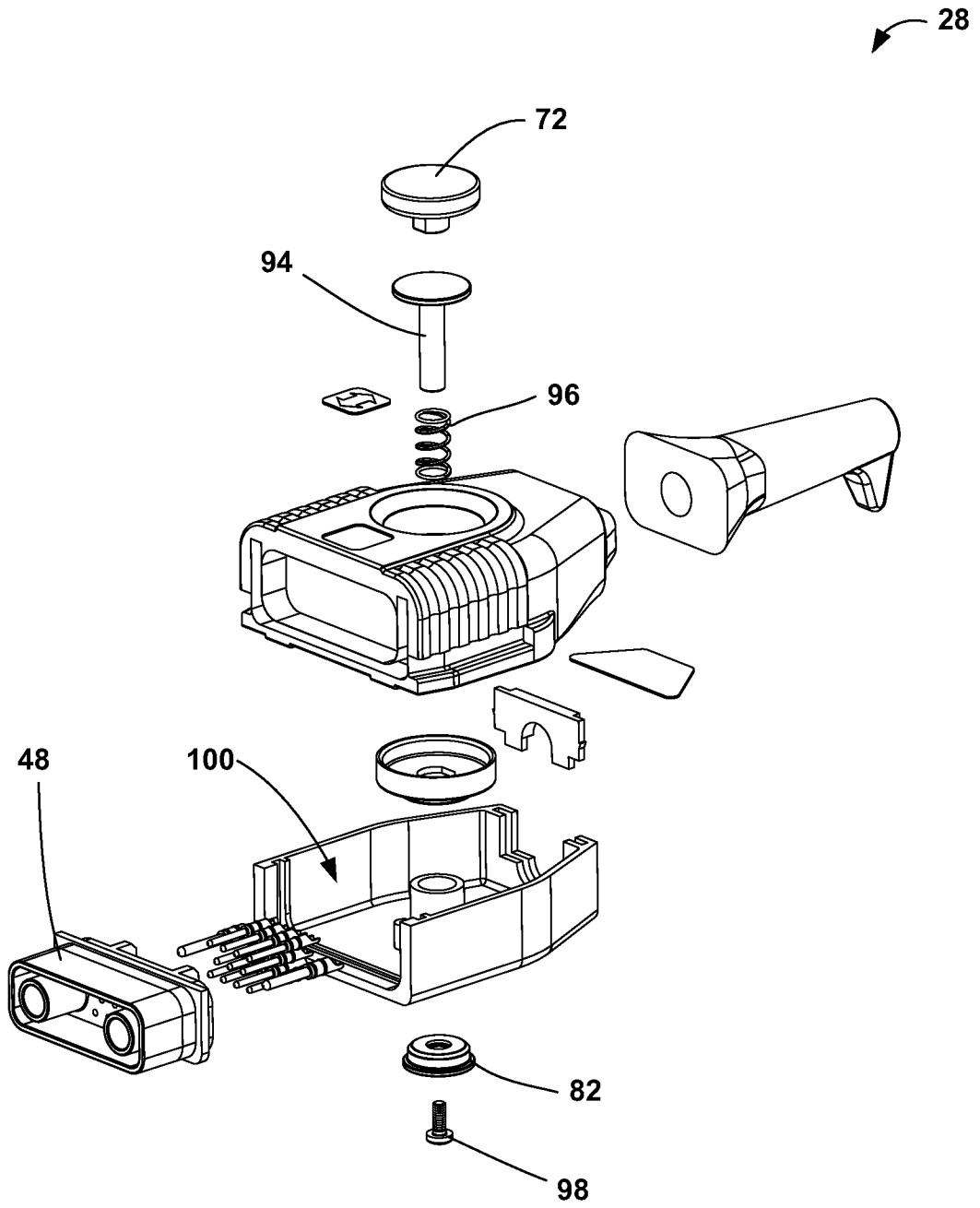


FIG. 5H

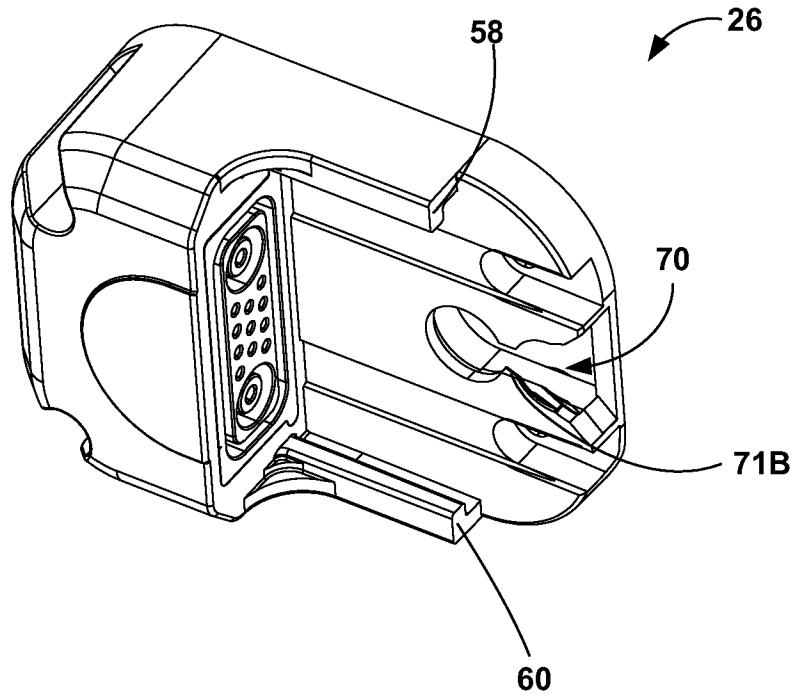


FIG. 6A

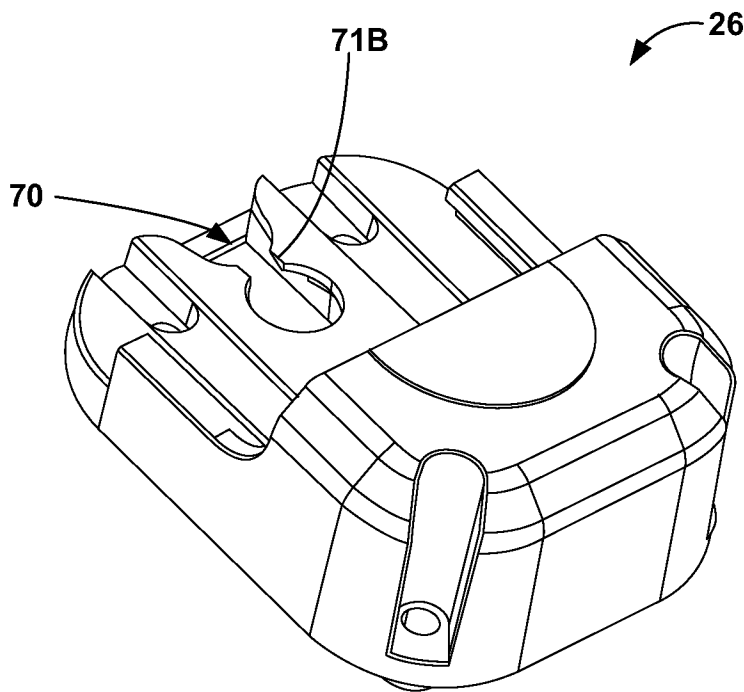


FIG. 6B

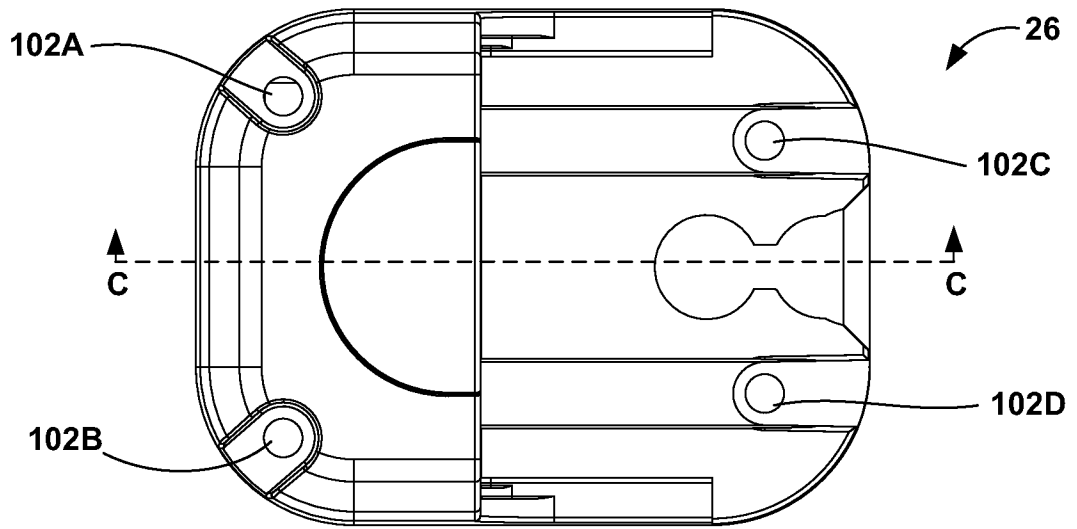


FIG. 6C

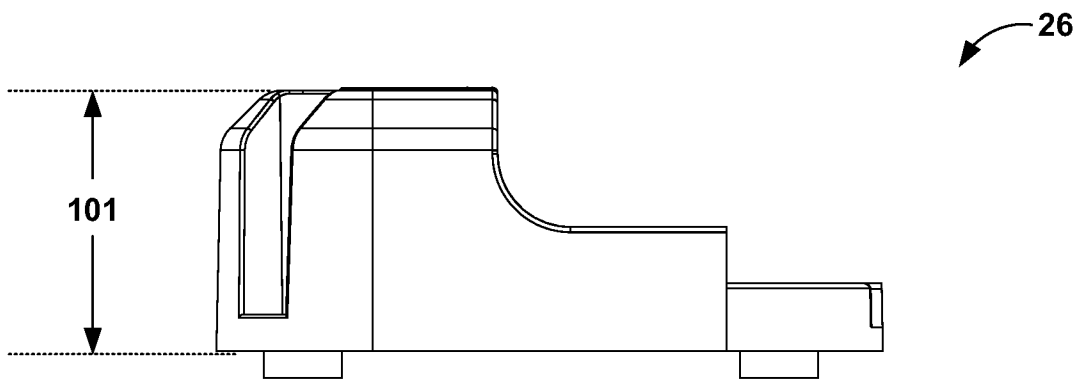


FIG. 6D

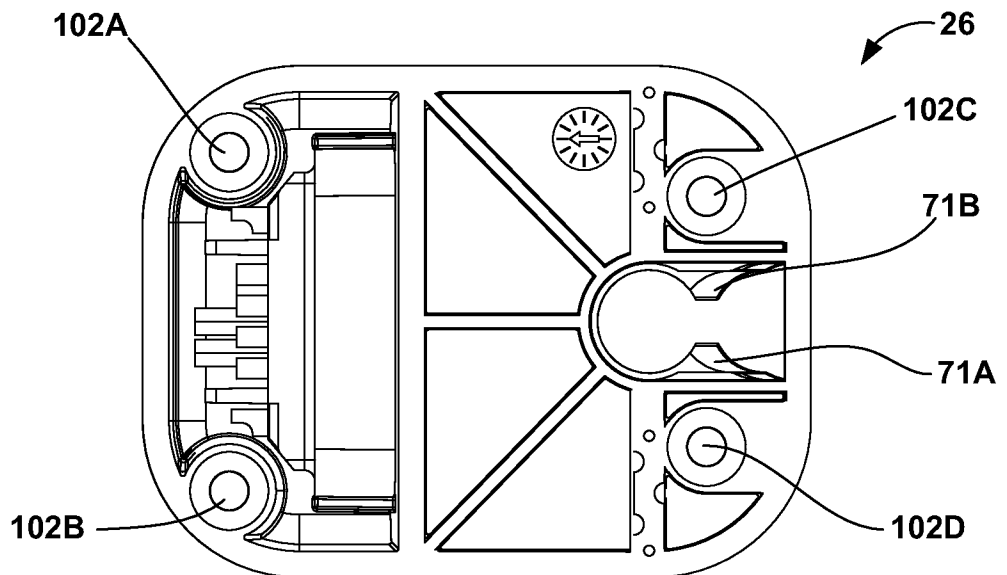


FIG. 6E

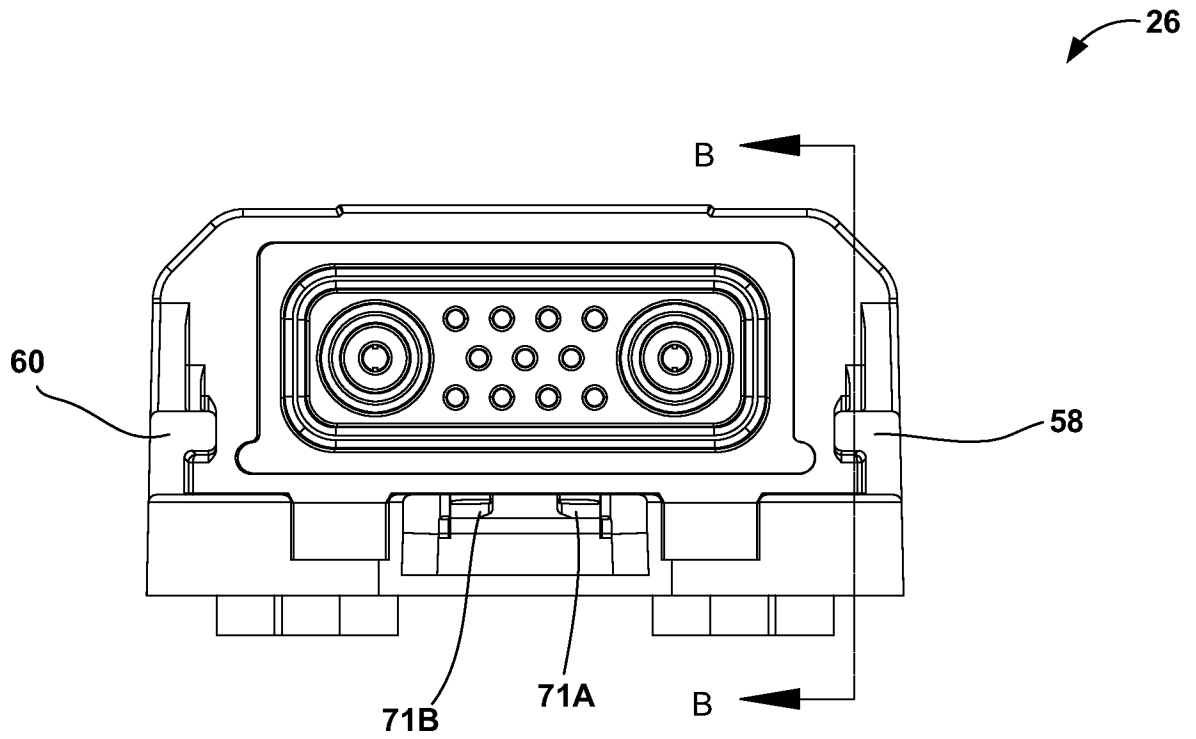


FIG. 6F

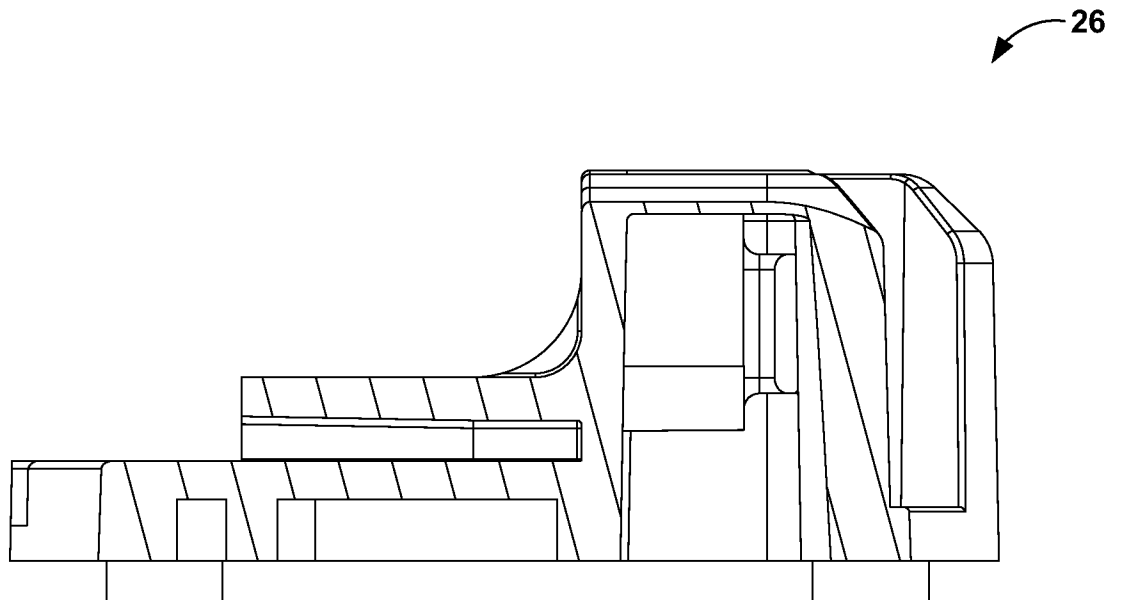


FIG. 6G

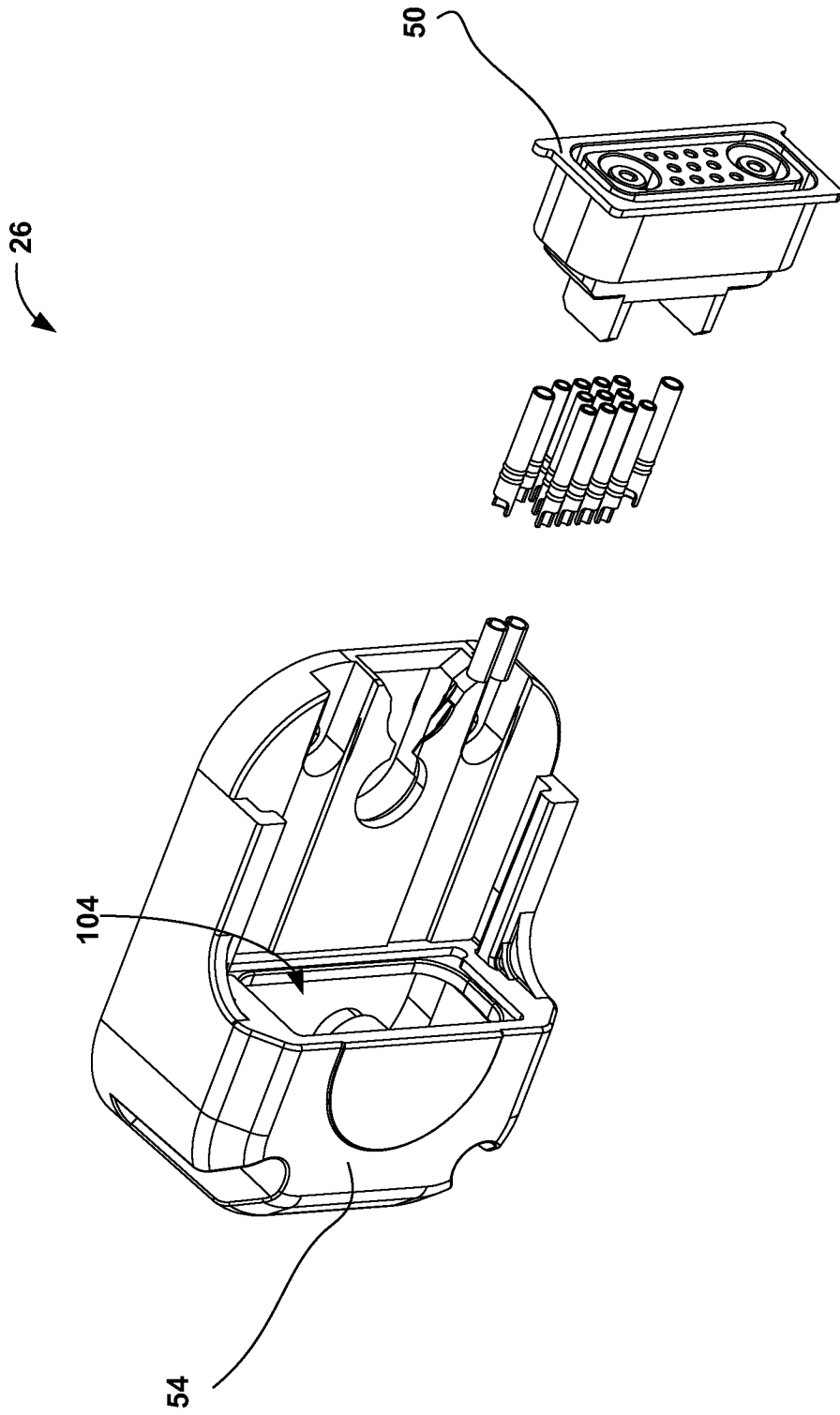


FIG. 6H

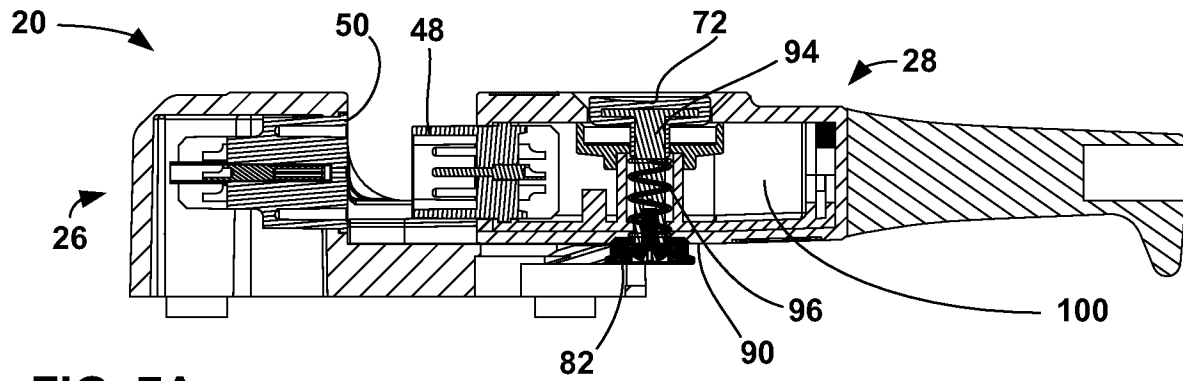


FIG. 7A

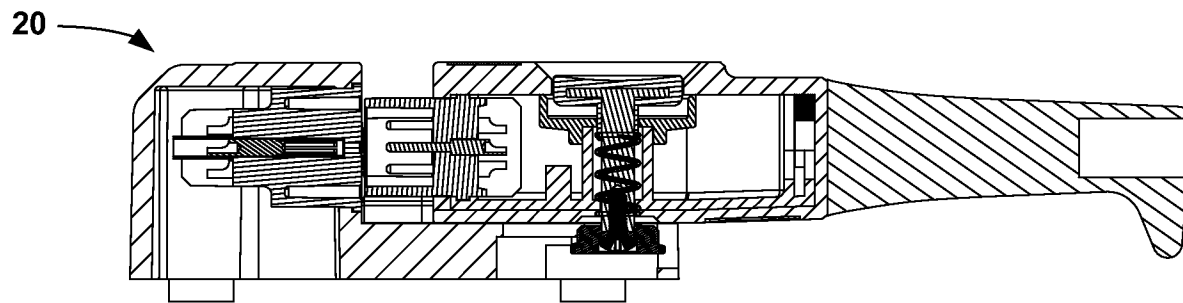


FIG. 7B

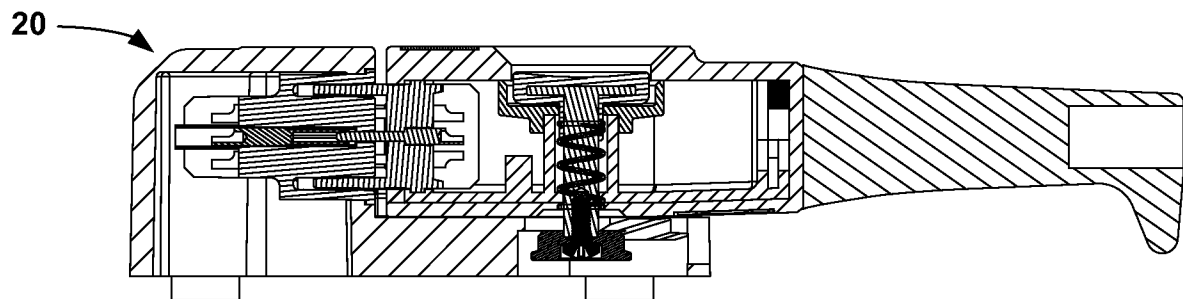


FIG. 7C

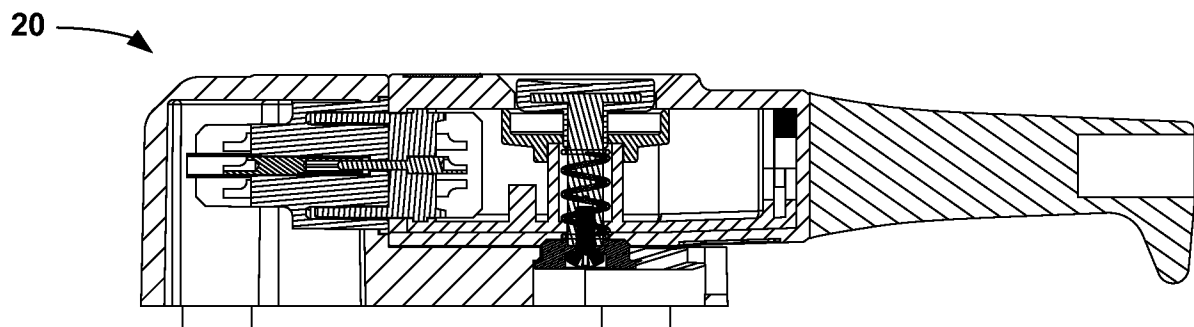


FIG. 7D

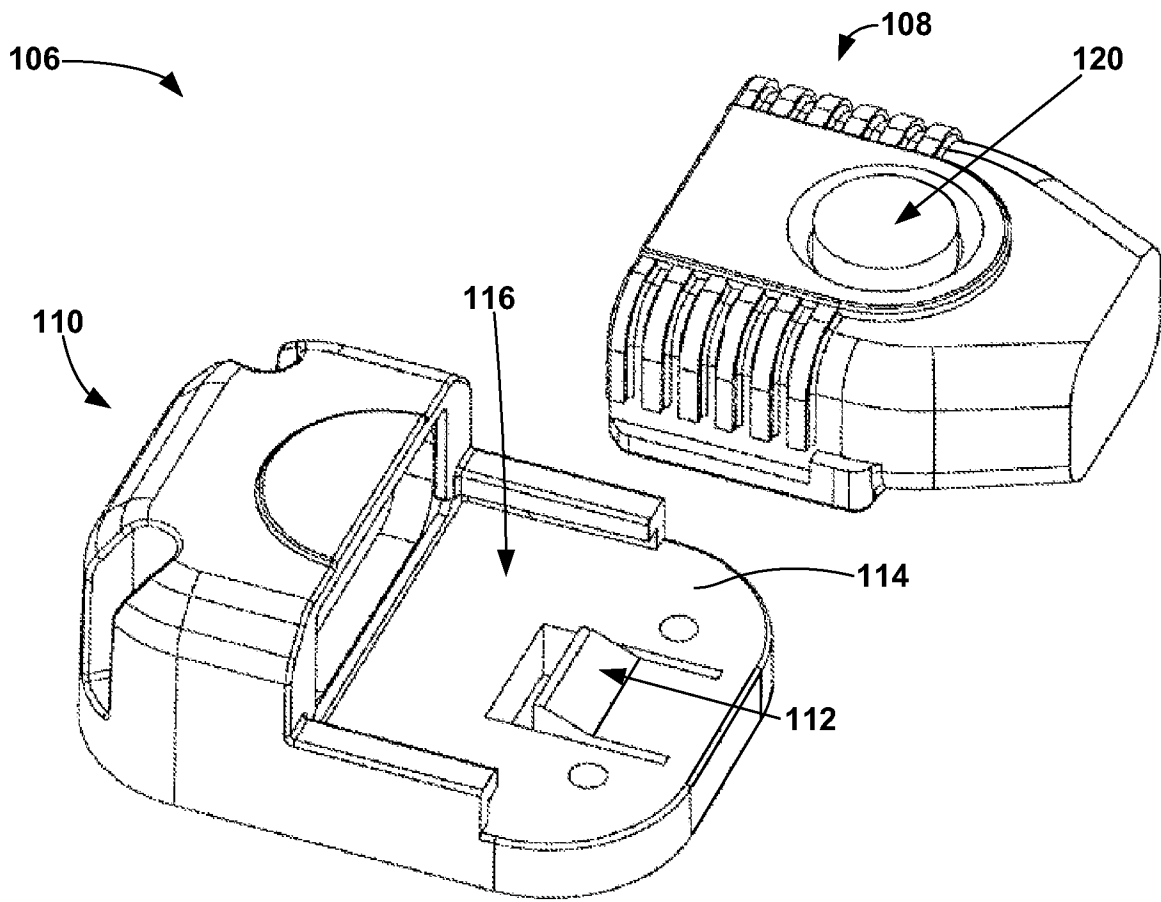


FIG. 8A

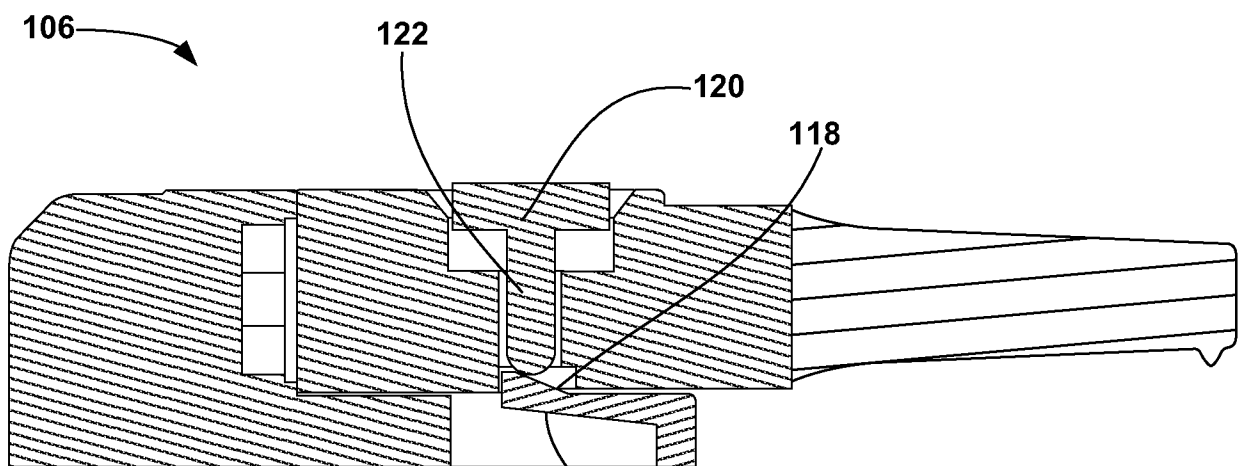


FIG. 8B

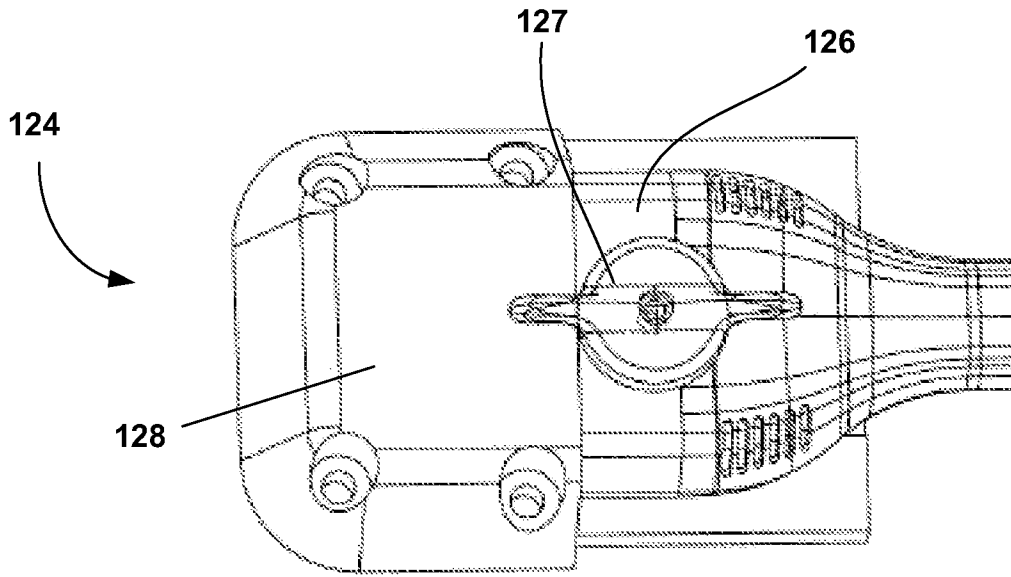


FIG. 9A

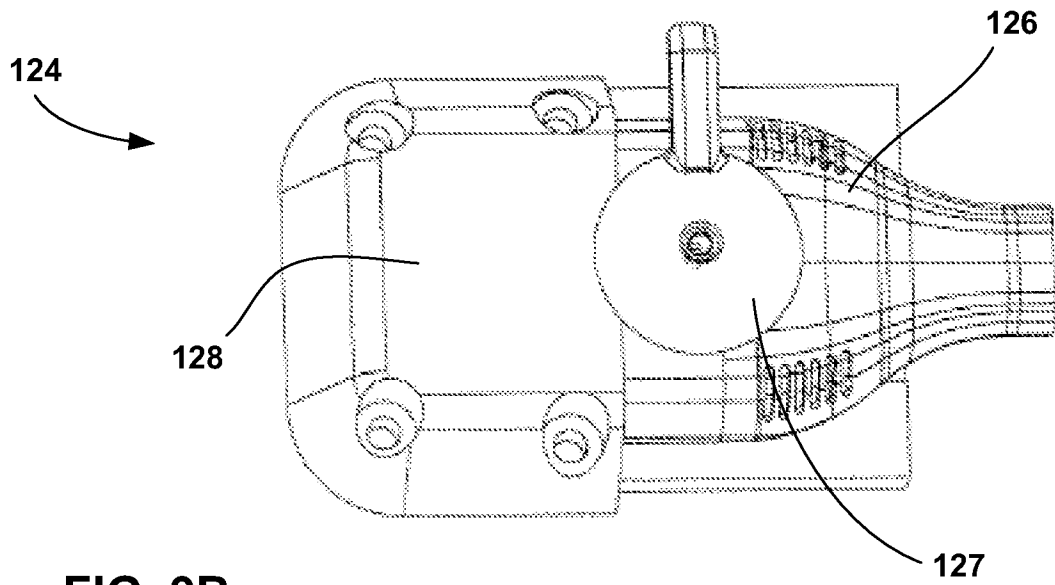


FIG. 9B

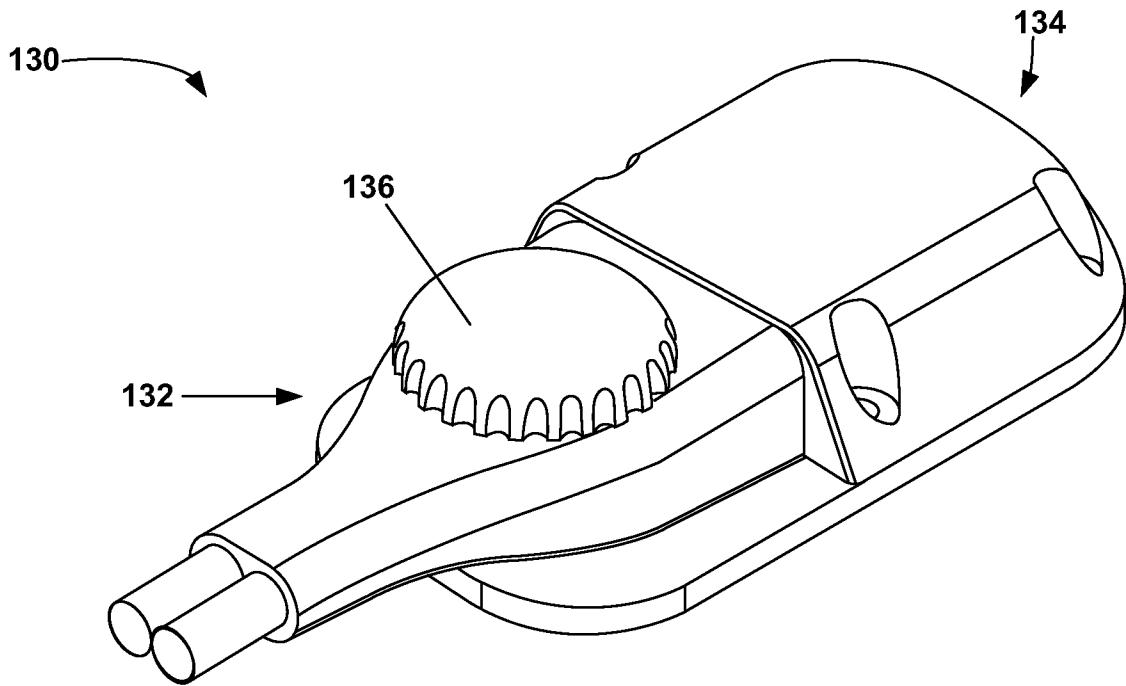


FIG. 10A

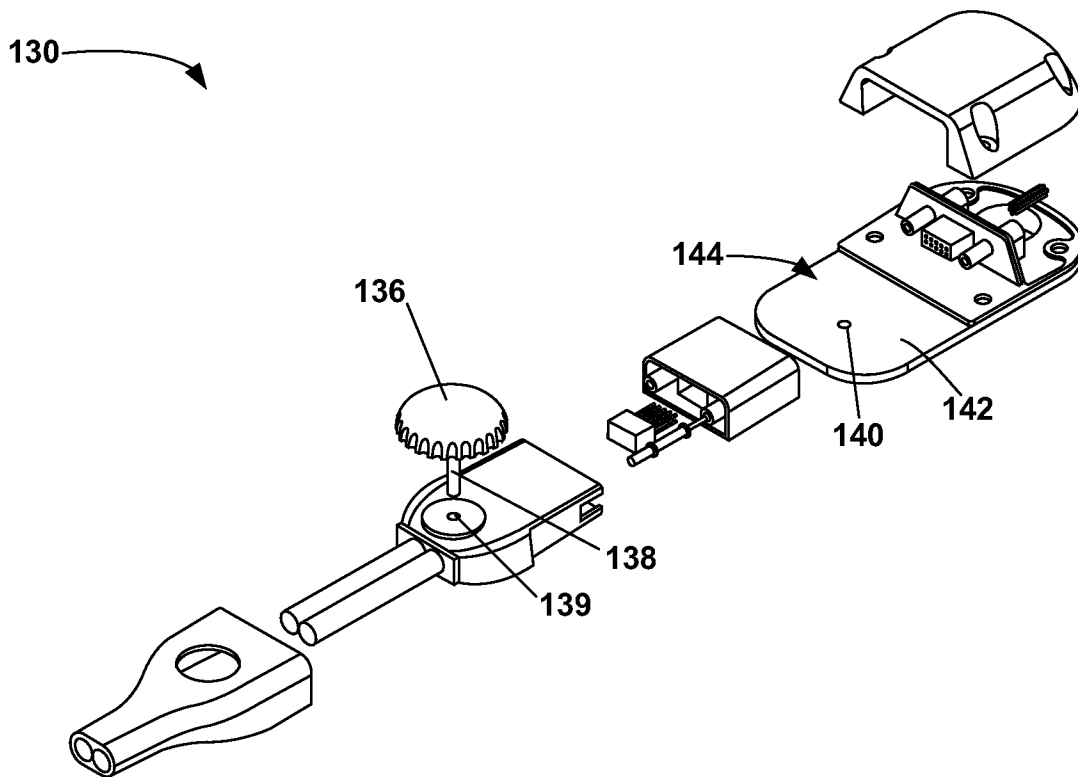
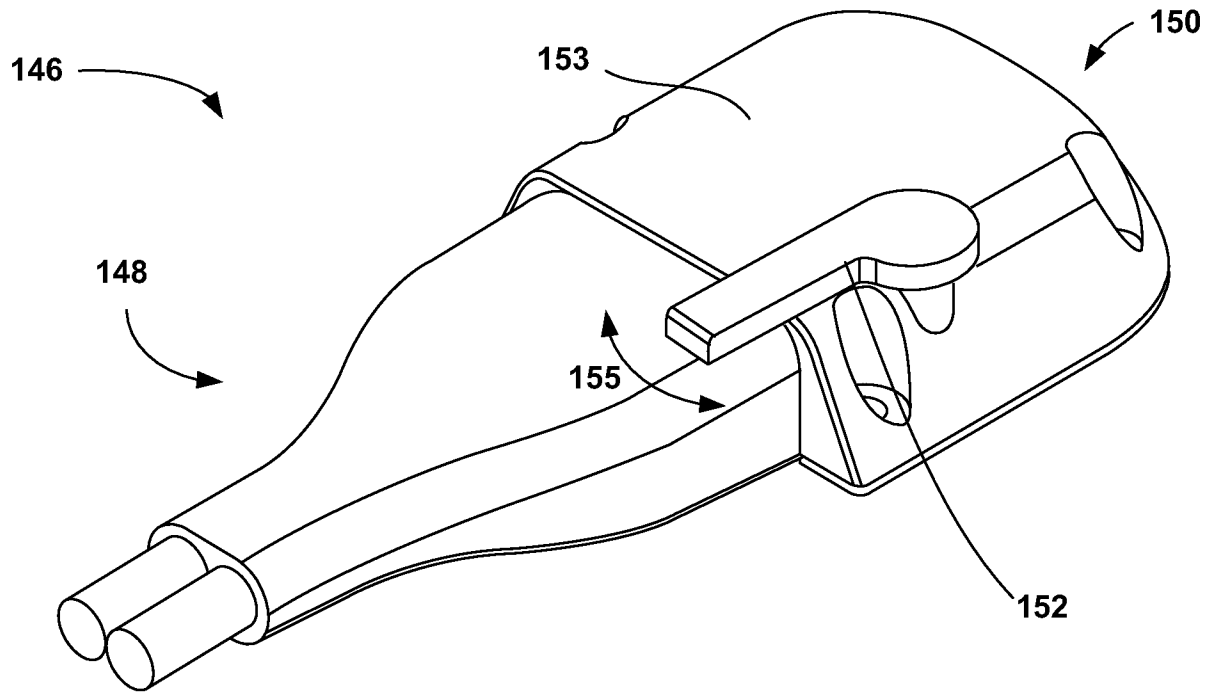
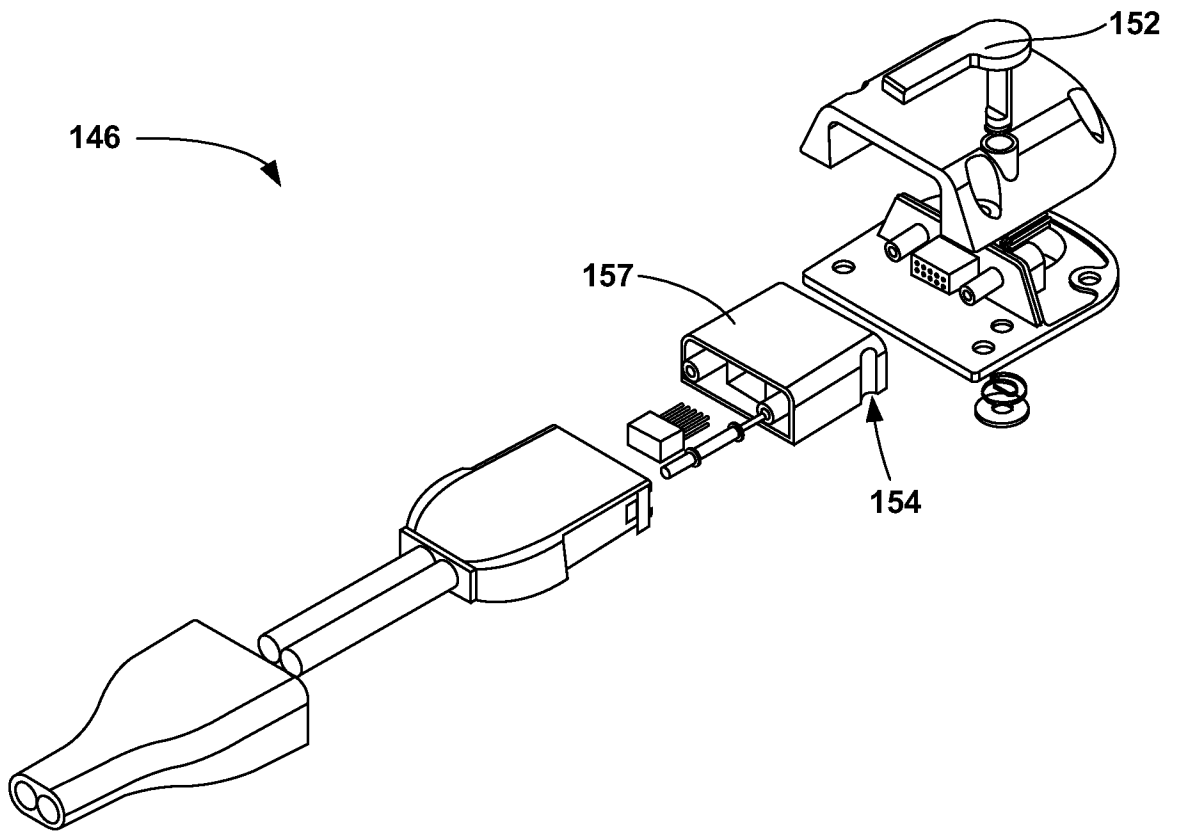


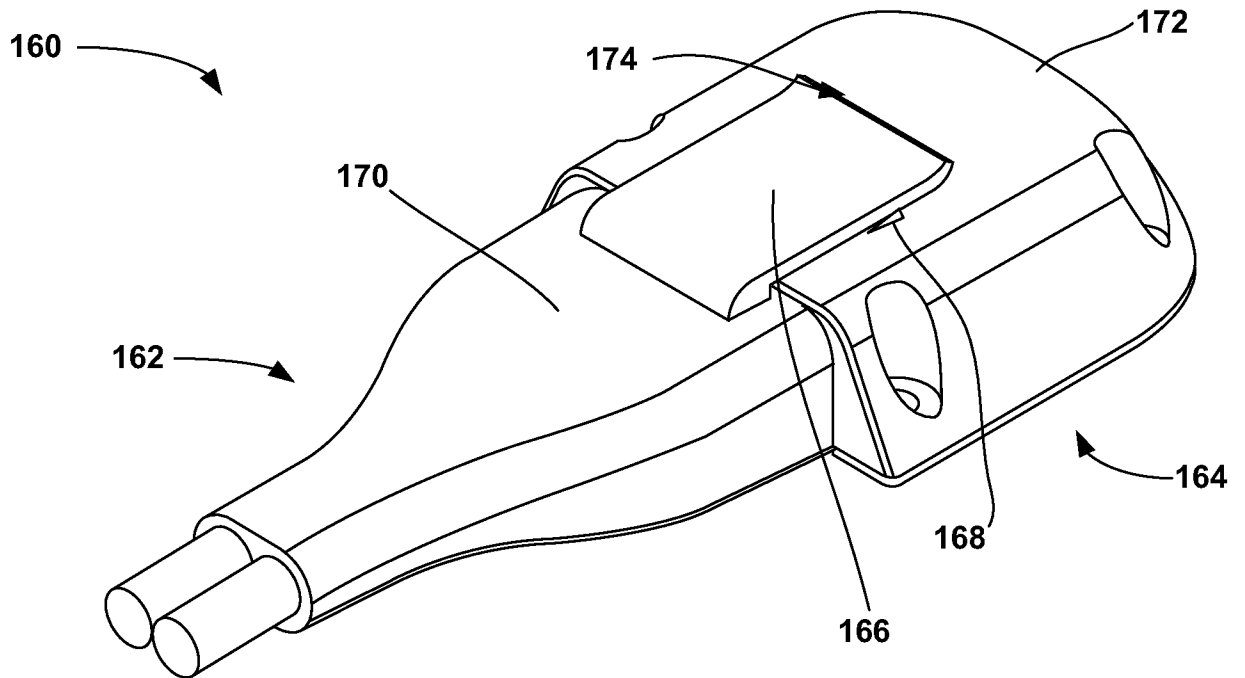
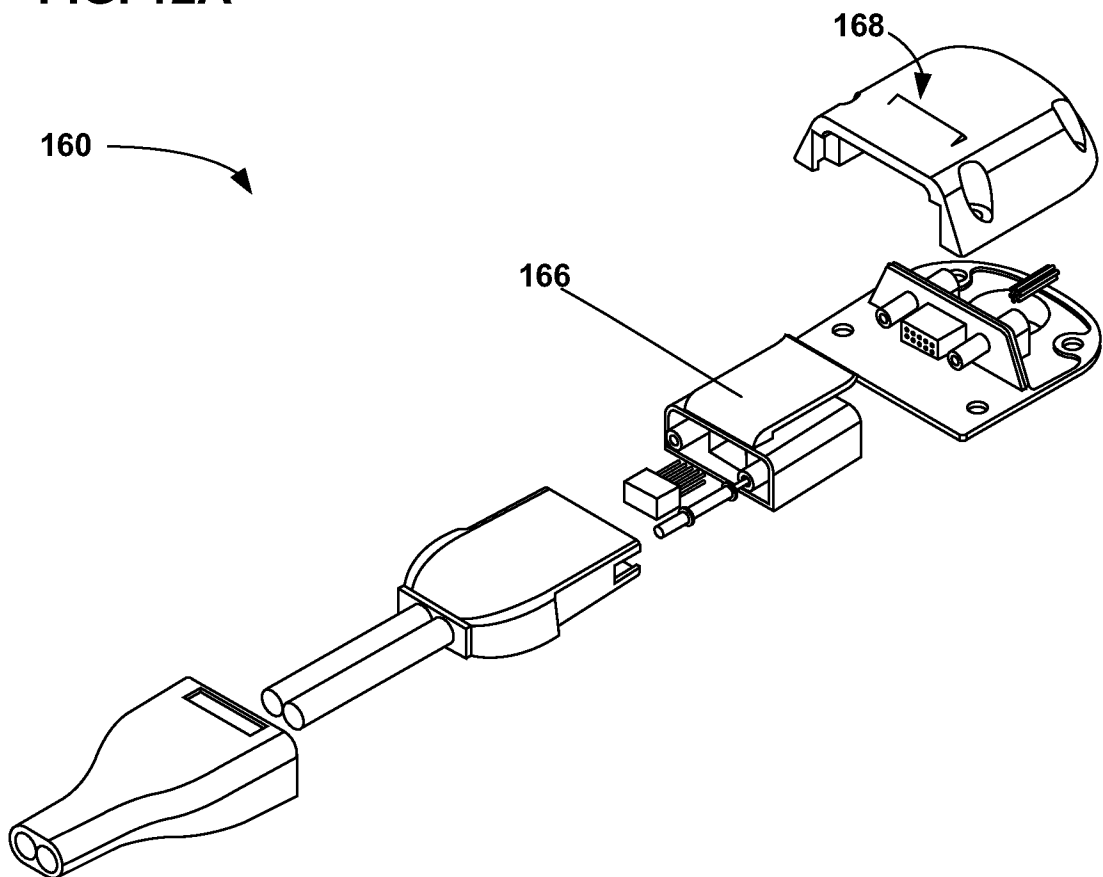
FIG. 10B

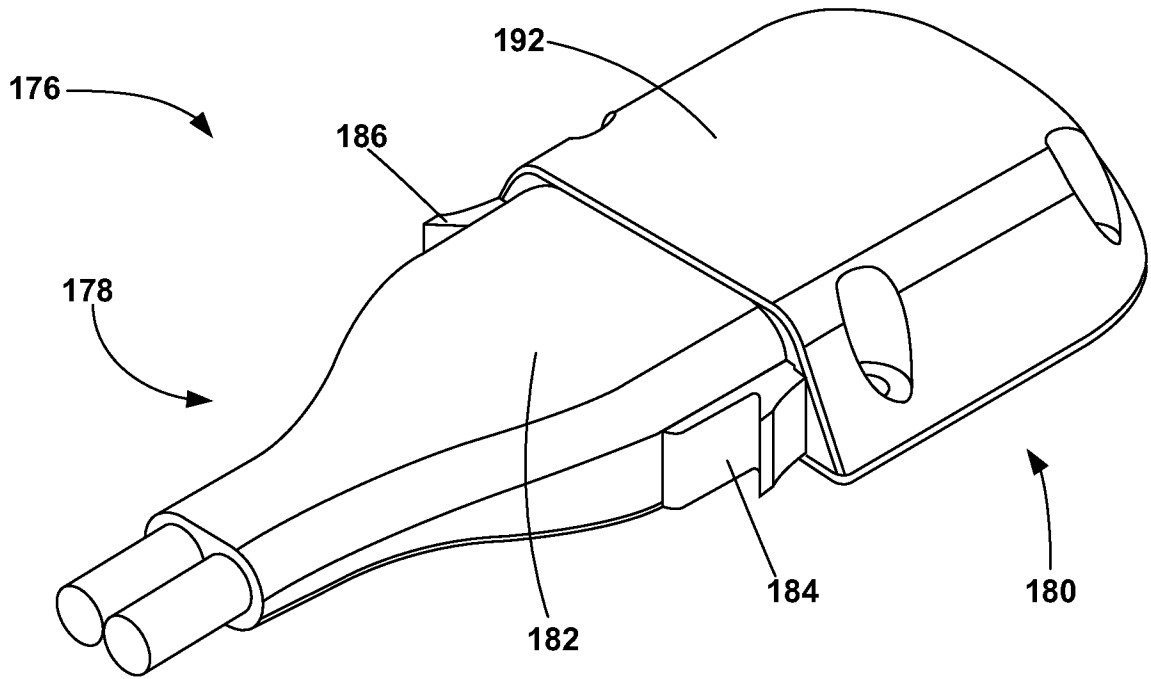


**FIG. 11A**

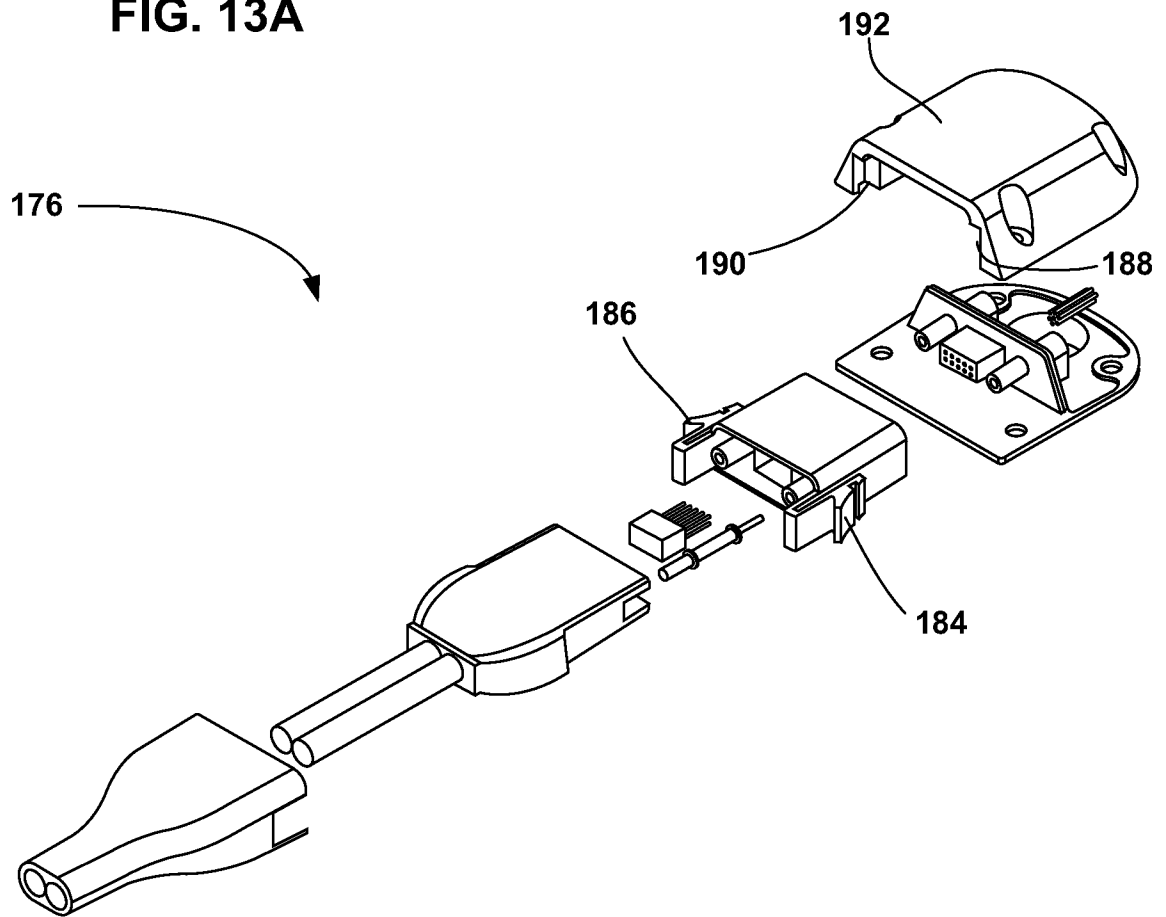


**FIG. 11B**

**FIG. 12A****FIG. 12B**



**FIG. 13A**



**FIG. 13B**

## INTERNATIONAL SEARCH REPORT

International application No.

PCT/US 09/57854

<b>A. CLASSIFICATION OF SUBJECT MATTER</b> IPC(8) - A61N 1/00 (2009.01) USPC - 607/5 According to International Patent Classification (IPC) or to both national classification and IPC		
<b>B. FIELDS SEARCHED</b> Minimum documentation searched (classification system followed by classification symbols) IPC(8) - A61N 1/00 (2009.01) USPC - 607/5 Documentation searched other than minimum documentation to the extent that such documents are included in the fields searched 607/1, 2, 4, 5, 115, 116, 119 601/15 Electronic data base consulted during the international search (name of data base and, where practicable, search terms used) PubWEST(USPT,PGPB,EPAB,JPAB); Google ; Search Terms Used: defibrillator, disposable, connector, slidable, slide, lock, electrodes, removable, replaceable, portable		
<b>C. DOCUMENTS CONSIDERED TO BE RELEVANT</b>		
Category*	Citation of document, with indication, where appropriate, of the relevant passages	Relevant to claim No.
X -- Y	US 2006/0058846 A1 (SMIRLES et al.) 16 March 2006 (16.03.2006) Entire document, especially Abstract, para[0025]-[0026], para[0039]- para[0046] and FIGS. 1, 10, 11-16.	1-4, 6-15, 17-21, 23-28 ----- 5, 16, 22
Y	US 2,810,050 A (JOHNSON), 15 October 1959 (15.10.1959), Entire document, especially col 4, ln 15-16	5, 16, 22
A	US 2003/0233129 A1 (MATOS) 18 December 2003 (18.12.2003) Entire document	1-28
<input type="checkbox"/> Further documents are listed in the continuation of Box C. <input type="checkbox"/>		
* Special categories of cited documents: "A" document defining the general state of the art which is not considered to be of particular relevance "E" earlier application or patent but published on or after the international filing date "L" document which may throw doubts on priority claim(s) or which is cited to establish the publication date of another citation or other special reason (as specified) "O" document referring to an oral disclosure, use, exhibition or other means "P" document published prior to the international filing date but later than the priority date claimed "T" later document published after the international filing date or priority date and not in conflict with the application but cited to understand the principle or theory underlying the invention "X" document of particular relevance; the claimed invention cannot be considered novel or cannot be considered to involve an inventive step when the document is taken alone "Y" document of particular relevance; the claimed invention cannot be considered to involve an inventive step when the document is combined with one or more other such documents, such combination being obvious to a person skilled in the art "&" document member of the same patent family		
Date of the actual completion of the international search 02 November 2009 (02.11.2009)		Date of mailing of the international search report <b>13 NOV 2009</b>
Name and mailing address of the ISA/US Mail Stop PCT, Attn: ISA/US, Commissioner for Patents P.O. Box 1450, Alexandria, Virginia 22313-1450 Facsimile No. 571-273-3201		Authorized officer: Lee W. Young PCT Helpdesk: 571-272-4300 PCT OSP: 571-272-7774