



(51) International Patent Classification:

A45D 34/04 (2006.01) A45D 40/26 (2006.01)
A45D 40/00 (2006.01)

(21) International Application Number:

PCT/EP2024/064877

(22) International Filing Date:

30 May 2024 (30.05.2024)

(25) Filing Language:

English

(26) Publication Language:

English

(30) Priority Data:

FR2305676 06 June 2023 (06.06.2023) FR

(71) Applicant: **L'OREAL** [FR/FR]; 14 Rue Royale, 75008 PARIS (FR).

(72) Inventors: **LEROUX, Stéphane**; c/o L'OREAL R&I RIO 9, rue Pierre Dreyfus, 92110 CLICHY (FR). **SCHREIBER, Camille**; CO/ L'OREAL R&I RIO 9 rue Pierre Dreyfus, 92110 CLICHY (FR).

(74) Agent: **THON, Julien** et al.; CASALONGA, 31 rue de Fleurus, 75006 PARIS (FR).

(81) Designated States (unless otherwise indicated, for every kind of national protection available):

AE, AG, AL, AM, AO, AT, AU, AZ, BA, BB, BG, BH, BN, BR, BW, BY, BZ, CA, CH, CL, CN, CO, CR, CU, CV, CZ, DE, DJ, DK, DM, DO, DZ, EC, EE, EG, ES, FI, GB, GD, GE, GH, GM, GT, HN, HR, HU, ID, IL, IN, IQ, IR, IS, IT, JM, JO, JP, KE, KG, KH, KN, KP, KR, KW, KZ, LA, LC, LK, LR, LS, LU, LY, MA, MD, MG, MK, MN, MU, MW, MX, MY, MZ, NA, NG, NI, NO, NZ, OM, PA, PE, PG, PH, PL, PT, QA, RO, RS, RU, RW, SA, SC, SD, SE, SG, SK, SL, ST, SV, SY, TH, TJ, TM, TN, TR, TT, TZ, UA, UG, US, UZ, VC, VN, WS, ZA, ZM, ZW.

(84) Designated States (unless otherwise indicated, for every kind of regional protection available):

ARIPO (BW, CV, GH, GM, KE, LR, LS, MW, MZ, NA, RW, SC, SD, SL, ST, SZ, TZ, UG, ZM, ZW), Eurasian (AM, AZ, BY, KG, KZ, RU, TJ, TM), European (AL, AT, BE, BG, CH, CY, CZ, DE, DK, EE, ES, FI, FR, GB, GR, HR, HU, IE, IS, IT, LT, LU, LV, MC, ME, MK, MT, NL, NO, PL, PT, RO, RS, SE, SI, SK, SM, TR), OAPI (BF, BJ, CF, CG, CI, CM, GA, GN, GQ, GW, KM, ML, MR, NE, SN, TD, TG).

(54) Title: REFILLABLE ASSEMBLY FOR PACKAGING A COSMETIC PRODUCT COMPRISING A DEVICE FORMING A REFILL AND A DEVICE FOR AXIAL RETENTION OF SAID DEVICE FORMING A REFILL IN A COVER ASSEMBLY

[Fig. 4]

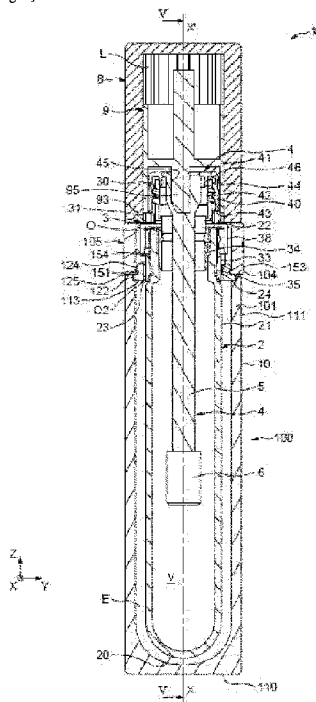

(57) Abstract: Refillable assembly (1) for packaging a product, notably a cosmetic product, extending axially along a longitudinal axis (X-X') and comprising at least a device forming a refill (10) comprising a container (2, 3) delimiting an internal volume (V) intended to receive the product, and a cover assembly (100) delimiting an internal space (E) for receiving the device forming a refill (10). The refillable assembly comprises a device for axial retention of the container (2, 3) relative to the cover assembly (100) comprising at least one flexible tab (123) extending axially along the longitudinal axis (X-X') of the refillable packaging assembly (1) and comprising an internal snap-fitting element (126) and at least one complementary external snap-fitting element (37) borne by the container (2, 3) and intended to interact with an internal snap-fitting element (126) of the flexible tab (123) of the cover assembly (100) in a position of axial retention of the container (2, 3) relative to the cover assembly (100).



WO 2024/251599 A1

Published:

- *with international search report (Art. 21(3))*
- *in black and white; the international application as filed contained color or greyscale and is available for download from PATENTSCOPE*

DESCRIPTION

TITLE: Refillable assembly for packaging a cosmetic product comprising a device forming a refill and a device for axial retention of said device forming a refill in a cover assembly

The present invention relates to the field of refillable assemblies for packaging a product, in particular a cosmetic product.

A “cosmetic product” is understood, in particular within the meaning of the present invention, to be a product as defined in Regulation (EC) No 1223/2009 of the European Parliament and of the Council of 30 November 2009 on cosmetic products.

More particularly, the invention relates to a refillable assembly for packaging a product comprising a container containing a product and a cover assembly for said container, in which the container is mounted.

The container forms a refill adapted to be replaced when the product it contains is used up.

Providing eco-responsible, environmentally-friendly solutions that are designed and developed to take into account environmental issues has become a major concern for tackling global challenges.

It has become apparent that it is therefore essential to design products that make it possible to reduce the amount of materials used and/or to substitute more environmentally friendly materials and/or to use recyclable materials so as to reduce the carbon footprint of the product.

In this context, it is important to develop forms of packaging that generate less waste, in particular packaging optimized for the amount of product transported, notably by redesigning and/or redimensioning the packaging so as to reduce the amount of packaging in terms of volume and weight.

The aim is to propose reusable eco-responsible containers, in particular containers that can be refilled in the home or in a shop, in order to reduce the carbon footprint of the packaging.

The present invention forms part of this strategy of developing refillable packaging for the field of cosmetic products, and in particular care or make-up products, notably for keratin fibres, in particular the eyelashes and/or eyebrows, such as a mascara, a product for making up the lips, such as a lipstick or a gloss, or a product for making up the skin, such as a concealer, applied to localized areas of the face.

Conventionally, whether in the field of packaging of cosmetic products or other products, the containers forming the refills take the form of minimalist assemblies, adapted to be combined with cover elements so as to form a ready-to-use packaging assembly offering the user optimal performance, in particular in terms of aesthetics and ease of use.

Document JP-B2-3638756 discloses a container forming a refill mounted in a cover element and held axially in said cover element by a ring that rotates as one with the cover element. Said ring comprises two protruding portions extending radially inwards and each intended to be placed selectively facing a shoulder provided on the container forming a refill in an axial holding position and thus prevent it from being axially removed from the cover element and facing a flat area provided on the shoulder of the container so as to allow it to be removed axially from the cover element.

Such a solution makes it possible to easily replace the container forming a refill.

However, there may be an axial clearance between the shoulder of the container forming a refill and the axial holding ring when said container is held axially in the cover element, which can be detrimental to the perception of quality of the assembly.

Furthermore, in the event of accidental rotation of the axial holding ring, there is a significant risk that the container forming a refill will unexpectedly come out of the cover element.

Document CN217285031 also discloses a ring for axially holding a container forming a refill in a cover element, comprising a push button intended to interact with a notch provided on the container forming a refill in an axial holding position. To detach the container forming a refill from the cover element, the user presses radially on the push button so as to elastically deform the axial holding ring and disengage said push button from the notch on the container forming a refill.

However, when the container forming a refill is detached from the cover element, the axial holding ring is also detached, such that there is a risk of said ring becoming lost.

Furthermore, if the push button is pressed accidentally, there is a significant risk that the container forming a refill will inopportunistically come out of the cover element.

Although they offer a solution of refillability for refillable assemblies for packaging a cosmetic product, the design of the axial holding rings according to these documents is not entirely satisfactory.

5 The present invention therefore aims to overcome the above disadvantages and improve refillable assemblies for packaging a product comprising a container forming a refill and a cover element, the aim being to enhance the axial retention of said container forming a refill relative to the cover element in a position of use of the product and to facilitate the removal of the container forming a refill from the cover element in the event of replacement of said container forming a refill.

10 Another aim of the invention is to enhance the perception of quality by the user and prevent any accidental removal of the container forming a refill.

The invention relates to a refillable assembly for packaging a product, notably a cosmetic product, extending axially along a longitudinal axis and comprising at least:

15 - a device forming a refill comprising a container or vial delimiting an internal volume intended to receive the product, and

- a cover assembly delimiting an internal space for receiving the device forming a refill.

The refillable packaging assembly comprises a device for axial retention of the container relative to the cover assembly comprising:

20 - at least one flexible tab extending axially along the longitudinal axis of the refillable packaging assembly and comprising an internal snap-fitting element; and

25 - at least one complementary external snap-fitting element borne by the container and intended to interact with an internal snap-fitting element of the flexible tab of the cover assembly in a position of axial retention of the container relative to the cover assembly.

The flexible tab is elastically deformable in the radial direction between an initial position in which said flexible tab extends axially along a first axis substantially parallel to the longitudinal axis and a deformed position in which said flexible tab extends along a second axis forming an angle with the longitudinal axis.

30 "Flexible" or "elastically deformable" means any member capable of deforming under the action of a stress exerted, for example the passage of the snap-fitting elements as a result of a removal force applied on the device forming a refill and tending to remove same from the cover assembly, and of returning to its initial shape after cessation of said stress.

The axial retention device makes it possible to ensure axial retention of the container of the device forming a refill relative to the cover assembly.

5 A “product” is understood to be a fluid or semi-fluid product, for example a care or make-up product, in particular for making up the lips, or a product for caring for or making up the epidermis of a user.

10 The axial retention system formed by the flexible tab and the snap-fitting element is adapted to ensure the retention of the device forming a refill relative to the cover assembly without requiring any relative movement between these elements other than a translational movement along the longitudinal axis, and in particular without requiring any relative movement of rotation of these elements about the longitudinal axis.

15 Thus, such an axial retention system allows the retention of the device forming a refill relative to the cover assembly regardless of the relative angular position of these elements about the longitudinal axis. In other words, to ensure the axial retention of the device forming a refill relative to the cover assembly, unlike prior art solutions the user does not need to place the device forming a refill in a particular angular position relative to the cover assembly about the longitudinal axis, and then turn these elements relative to one another about the longitudinal axis, which makes it possible to improve the ergonomics and the ease of use of the refillable assembly.

20 According to an embodiment, the device for axial retention of the container relative to the cover assembly comprises at least two flexible tabs distributed circumferentially, for example regularly or irregularly, around the cover assembly.

Preferably, the two flexible tabs are diametrically opposite.

25 Axially holding the container of the device forming a refill relative to the cover assembly via at least two flexible tabs makes it possible to improve the stability of said axial holding.

30 According to an embodiment, the complementary external snap-fitting element provided on the container may be a single element, for example in the form of a circumferential groove or rib and interact with a single flexible tab or a plurality of flexible tabs.

In general, the complementary external snap-fitting element may take the form of a rib or a groove which is continuous or discontinuous in the circumferential direction. In the latter case, the rib or groove segments are adapted to interact with an internal snap-fitting element of a corresponding flexible tab.

Advantageously, the refillable packaging assembly further comprises a device for locking/unlocking the device for axial retention of the container relative to the cover assembly.

5 As a variant, it is possible to provide for the refillable packaging assembly to be without such a locking/unlocking device.

Advantageously, the locking/unlocking device comprises an axial holding ring, which is axially rigidly secured to the cover assembly and comprises at least one radial protrusion extending radially inwards.

10 The axial holding ring is rotatable about the longitudinal axis relative to the cover assembly between a locked position, in which the radial protrusion is radially behind the flexible tab provided with an internal snap-fitting element so as to block radial bending of said tab and thus prevent manual removal of the container from the cover assembly, and an unlocked position, in which the radial protrusion is angularly offset from the flexible tab provided with an internal snap-fitting element so as to allow
15 said flexible tab to bend radially and thus allow manual removal of the container from the cover assembly by virtue of an axial removal force applied on said container, causing the flexible tab provided with an internal snap-fitting element to move away radially.

20 The locking/unlocking device ensures reliable axial holding of the refillable device in the cover assembly.

The axial retention device makes it possible to improve the quality of axial holding of the device forming a refill in the cover assembly, advantageously without play while limiting the risk of inopportune removal of the device forming a refill in the event of accidental rotation of the axial holding ring.

25 The axial holding ring is non-removable, rotating as one with the cover assembly, notably with the yoke.

As a variant, a different number of radial protrusions of the axial holding ring could be provided.

30 In general, the number of radial protrusions of the axial holding ring corresponds to the number of flexible tabs provided with an internal snap-fitting element.

Advantageously, the axial holding ring is rigid, in other words it is not elastically deformable.

According to an embodiment, the cover assembly comprises a closed lower end forming a bottom, an open upper end, opposite the bottom, having a neck and allowing access to the internal space for receiving the container, and a peripheral side wall extending between the bottom and the open upper end.

5 For example, the flexible tab is borne by the neck of the cover assembly. In the case where there are several flexible tabs, each of the flexible tabs is borne by the neck of the cover assembly.

According to an embodiment, the neck of the cover assembly comprises two groups of three flexible tabs, said flexible tabs of each group being spaced apart by a first circumferential clearance and the two groups being spaced apart from one another by a second circumferential clearance.

For example, the first circumferential clearance is smaller than or equal to the second circumferential clearance.

For example, the second circumferential clearance is comprised between the angular extent of a flexible tab and the angular extent of a flexible tab plus two first circumferential clearances.

As a variant, it is possible to provide for the neck of the cover assembly to comprise at least three flexible tabs spaced apart from one another circumferentially, preferably regularly.

20 Advantageously, at least one flexible tab of each group of three flexible tabs is provided with an internal snap-fitting element.

As a variant, at least two flexible tabs of each group of three flexible tabs are each provided with an internal snap-fitting element.

The internal snap-fitting element is, for example, located at the upper free end of the flexible tab.

For example, the two flexible tabs located at the circumferential ends of each group of three flexible tabs are each provided with an internal snap-fitting element.

For example, the internal snap-fitting element borne by the flexible tab is an internal bead protruding radially inwards, and the complementary snap-fitting element borne by the container is an external bead protruding radially outwards or a groove.

30 Thus, in the case of a plurality of flexible tabs, the neck of the cover assembly comprises snap-fitting gadrooning that is discontinuous in the circumferential direction, in other words formed of a plurality of snap-fitting beads separated from one another in the circumferential direction and being housed axially under a

complementary snap-fitting bead or in a complementary snap-fitting groove, borne by the container.

The complementary snap-fitting bead or the complementary snap-fitting groove may be annular or discontinuous in the circumferential direction.

5 Advantageously, the internal snap-fitting elements borne by the flexible tabs are regularly distributed circumferentially.

10 According to an embodiment, the axial holding ring comprises at least one radial rib and the neck of the cover assembly comprises at least one external snap-fitting element intended to interact with said radial rib so as to axially rigidly secure said ring to the cover assembly.

According to an embodiment, at least one flexible tab of each group of flexible tabs comprises an external snap-fitting element.

15 For example, the external snap-fitting element comprises a bead protruding radially outwards and a snap-fitting groove located axially directly under said bead and intended to interact with the radial rib provided on the axial holding ring.

For example, an external snap-fitting element extends in each of the second circumferential clearances.

As a variant, it is possible to provide for the second circumferential clearances to be without any flexible tab or internal snap-fitting element.

20 For example, the external snap-fitting elements are or are not borne by the same flexible tabs as bear the internal snap-fitting elements.

According to an embodiment, the axial holding ring comprises, on its inner wall, at least one axial rib extending axially at least over a part of the height of the axial holding ring.

25 According to another embodiment, the axial holding ring comprises, on its inner wall, at least two axial ribs extending axially at least over a part of the height of the axial holding ring and intended to each be inserted between two flexible tabs in the locked position of the ring, notably in the first circumferential clearance, thus forming a device for indicating by touch and/or sound that the ring is in position, notably in the
30 locked position.

For example, the axial ribs are located circumferentially opposite one another.

For example, an axial rib is located circumferentially between two radial protrusions.

For example, the axial ribs have a semi-circular section so that the flexible tab can easily get past them upon rotation of the ring.

According to an embodiment, the axial holding ring comprises, on its inner wall, at least one circumferential stop extending radially inwards and intended to come into circumferential abutment against the flexible tab in the locked position of the ring, thus forming a circumferential stop device in the locked position.

According to an embodiment, the axial holding ring comprises, on its inner wall, at least two circumferential stops extending radially inwards and each intended to come into circumferential abutment against one of the flexible tabs in the locked position of the ring, notably to be inserted in the second circumferential clearance.

For example, the two circumferential stops are located circumferentially opposite one another.

For example, a circumferential stop is located circumferentially between two radial protrusions.

Advantageously, the circumferential stops and the axial ribs are arranged alternating and spaced apart from one another circumferentially, preferably regularly.

For example, the axial holding ring comprises an outer wall, for example of polygonal section, and an inner wall of circular section.

As a variant, other shapes could be envisaged for the section of the outer wall of the axial holding ring, such as circular, ovoid, oblong, polygonal, for example square or rectangular, especially with rounded corners, or another shape.

The section of the outer wall of the axial holding ring may be identical and have the same dimension as the section of the cover case so as not to form radial protuberances. The risk of accidental actuation of the axial holding ring is thus limited.

Conversely, the section of the outer wall of the axial holding ring may be different and/or have a dimension different to the section of the cover case, so as to form one or more radial protuberances on the axial holding ring protruding from the cover case, for the purpose of facilitating gripping and actuation of the axial holding ring.

According to an embodiment, the container of the device forming a refill comprises a main body extending along the longitudinal axis and an associated element, attached to the main body and defining a neck and a shoulder of the container.

As a variant, it is possible to provide for the main body and the associated element to form a single piece of the container.

In general, the device forming a refill comprises a side wall extending between the bottom and the neck and connected to the latter via the shoulder.

5 A “shoulder” means any surface substantially normal to the axis of elevation of a cylindrical part, in this case the longitudinal axis of the container, resulting from a sudden change in diameter, or more generally in a dimension in the radial direction, orthogonal to the longitudinal axis.

10 Advantageously, the main body of the container is provided with a closed lower end forming a bottom and with an open upper end, opposite the lower end, provided with an opening allowing access to the internal volume for receiving the product.

The open end is, for example, connected to the bottom by a recess extending radially inwards and a groove located axially between the recess and the open end.

The associated element is, for example, attached at the open end of the main body.

15 For example, the associated element comprises a sealing skirt mounted through the open end in the main body and an attachment skirt extending radially around the sealing skirt. The attachment skirt forms the side wall of the associated element.

20 The attachment skirt is connected to the neck by means of the shoulder and defines, with the sealing skirt, an annular space for receiving the portion of the main body extending between the recess and the open end.

25 Preferably, the associated element is attached and rigidly secured to the main body, in translation along and in rotation about the longitudinal axis, by the interaction of the groove, which is notably discontinuous in the circumferential direction, in other words formed of a plurality of cavities separated from one another in the circumferential direction, and gadrooning, which is notably discontinuous in the circumferential direction, in other words formed of a plurality of bosses separated from one another in the circumferential direction and received in the corresponding cavities of the groove.

30 The side wall of the vial is defined by the side wall of the main body located between the bottom and the recess, and by the attachment skirt of the associated element. Preferably, the recess and the attachment skirt are dimensioned such that the outer surface of the side wall of the main body located between the bottom and the

recess is flush with the outer surface of the attachment skirt when the associated element is attached to the main body.

According to an embodiment, the cover assembly comprises a cover case and a support or mounting yoke, attached to the cover case and defining the neck and notably the shoulder of the cover assembly.

As a variant, it is possible to provide for the cover case and the mounting yoke to form a single piece.

For example, the cover case is provided with a closed lower end forming a bottom and with an open upper end, opposite the lower end, provided with an opening allowing access to an internal space for receiving the container, the mounting yoke being attached at the open end of the cover case.

Advantageously, the open end is connected to the bottom by a peripheral wall of the cover assembly and said peripheral wall comprises, on its inner surface, an axial furrow extending axially from the open end and intended to interact with a radial flange provided at the lower end of the mounting yoke.

According to a particular arrangement, the peripheral wall of the cover assembly has at least one circumferential through window or opening, allowing the user to see part of the container of the device forming a refill through the cover assembly when it is received in the latter.

For example, the mounting yoke is attached to the cover case by any suitable means, for example, by adhesive bonding, screwing or by snap-fitting.

For example, the peripheral wall of the mounting yoke is discontinuous and comprises at least one flexible tab extending axially from the radial flange.

The flexible tab extends axially from the radial flange and is flexible in the radial direction, in other words capable of deforming radially elastically under the action of an external stress, in this case the passage of a complementary snap-fitting element provided on the container, notably the associated element, as a result of a removal force applied on the device forming a refill and tending to remove it from the cover assembly, and of returning to its initial position after the cessation of the external stress.

According to an embodiment, the container, notably the associated element, further comprises at least one rotation blocking element, for example in the form of two axial tabs, intended to be inserted circumferentially between two flexible tabs, or

groups of flexible tabs, notably in said second circumferential clearance, so as to block rotation of the container relative to the cover assembly, notably to the mounting yoke.

Thus, in the embodiment illustrated, the associated element is attached and rigidly secured to the mounting yoke, in translation along and in rotation about the longitudinal axis, by the interaction of the snap-fitting beads, and by the interaction of the axial tabs each with a second circumferential clearance.

According to an embodiment, the device forming a refill comprises a closure element mounted on the container and closing off access to the internal volume.

According to an embodiment, the closure element belongs to a sub-assembly for applying a cosmetic product, further comprising an applicator member extending inside the internal volume of the container when the closure element closes off the container, and a stem connecting the closure element and the applicator member.

For example, the neck of the device forming a refill is provided with a radially outer screw thread interacting with an inner screw thread provided on the closure element.

According to an embodiment, the packaging assembly further comprises a covering and gripping cap for the device forming a refill.

For example, the closure element has a central axis coinciding with the longitudinal axis of the container when the closure element closes off the latter and comprises means for rigidly securing in translation along the central axis and means for rigidly securing in rotation about the central axis to the covering and gripping cap.

According to a second aspect, the invention relates to a method for refilling a refillable assembly for packaging a cosmetic product as described above, comprising at least the following steps:

- applying an outward axial removal force so as to cause the flexible tab provided with an internal snap-fitting element of the cover assembly, notably of the mounting yoke, to move away under the effect of the complementary external snap-fitting element provided on the container, so as to remove, preferably manually, said container of the used device forming a refill from the cover assembly;

- supplying a new device forming a refill; and

- inserting and attaching said new device forming a refill in the internal space of the cover assembly, until snap-fitting of the axial retention device formed by the interaction between the internal snap-fitting element of the cover assembly and the complementary external snap-fitting element provided on the container.

Advantageously, the refillable packaging assembly comprises an axial holding ring rigidly secured axially to the cover assembly and comprising at least one radial protrusion extending radially inwards, said ring being rotatable relative to the cover assembly. The refilling method then advantageously comprises, before the step of applying an axial removal force, a step consisting in:

5 - rotating the axial holding ring in a first direction of rotation until the radial protrusion of said ring is angularly offset from the flexible tab provided with the internal snap-fitting element of the cover assembly; and then advantageously comprising, after the step of inserting and attaching a new device forming a refill, a step consisting in:

10 - rotating the axial holding ring in a second direction of rotation, opposite to the first direction of rotation, until the radial protrusion of said ring is radially behind the flexible tab provided with the internal snap-fitting element, thus locking the axial retention device in the axial retention or snap-fitting position.

15 According to a particular arrangement, the refillable assembly further comprises a covering and gripping cap for the device forming a refill. The refilling method advantageously then comprises, preferably before the step of rotating the axial holding ring in the first direction of rotation, a step consisting in removing a covering and gripping cap from a closure element belonging to the used device forming a refill, and then comprising, preferably after the step of rotating the axial holding ring in the second direction of rotation, a step consisting in repositioning, on the new device forming a refill, the covering and gripping cap which was fitted on the used device forming a refill.

20 The present invention will be understood more clearly from studying the detailed description of embodiments that are given by way of entirely non-limiting examples and are illustrated by the appended drawings, in which:

[Fig. 1]

is a perspective view of a refillable assembly for packaging a product according to an embodiment of the invention;

30 [Fig. 2]

is an exploded perspective view of the refillable packaging assembly in Figure 1;

[Fig. 2A]

is a perspective view of the mounting yoke belonging to the cover assembly of the refillable packaging assembly in Figure 2;

[Fig. 3]

5 shows an overall face-on view of the refillable assembly for packaging a cosmetic product in Figure 1, in which the cap is shown in longitudinal section so as to reveal the elements housed within it;

[Fig. 4], [Fig. 5]

10 are views of the refillable packaging assembly in Figure 3 in longitudinal section in a first sectional plane IV-IV and in a second sectional plane V-V, respectively;

[Fig. 6], [Fig. 7]

are exploded views of Figure 3 and Figure 4, respectively, in which the cap has been omitted for the sake of clarity;

[Fig. 8A]

15 is a view of the axial holding ring in section in the sectional plane 8A-8A in Figure 7;

[Fig. 8B]

is a view from below of the axial holding ring of the refillable packaging assembly in Figure 1;

20 [Fig. 9]

is a face-on view of the device forming a refill of the refillable packaging assembly in Figure 1;

25 [Fig. 10], [Fig. 11], [Fig. 12] and [Fig. 13] are face-on views of various successive positions showing the closure element being screwed on the neck of the device forming a refill, Figure 13 corresponding to the position in which the closure element arrives at the end of screwing travel and closes off the neck of the device forming a refill, and in which the tab of the anti-opening device is in the position for blocking rotation of the closure element relative to the neck of the device forming a refill in the direction of unscrewing;

30 [Fig. 14]

is a view in longitudinal section of the device forming a refill according to another embodiment of the invention;

[Fig. 15]

is a perspective view of a refillable assembly for packaging a product according to another embodiment of the invention;

[Fig. 16]

5 is an exploded perspective view of the refillable packaging assembly in Figure 15;

[Fig. 17]

is a view in longitudinal section of the refillable packaging assembly in Figure 15; and

10 [Fig. 18A], [Fig. 18B], [Fig. 18C], [Fig. 18D] and [Fig. 18E] are face-on views showing the successive steps for replacing the device forming a refill.

In the rest of the description, reference will be made to an orthonormal system X, Y, Z, where Z corresponds to an axis of elongation representing the vertical direction, and in which there are:

15 - a longitudinal axis X, which is horizontal and extends from left to right in Figure 5;

- a transverse axis Y, which is horizontal, perpendicular to the longitudinal axis X, and extends from front to rear in Figure 5; and

- a vertical axis Z, which is orthogonal to the longitudinal axis X and transverse axis Y and extends from bottom to top in Figure 5.

20 The expressions “upper” and “lower” refer to the upper part and the lower part of the figures, in the assembled position of the refillable assembly.

As shown in Figures 1 to 7, a refillable assembly 1 for packaging a product extends axially along an axis X-X' presumed to be vertical in Figure 1.

25 The refillable assembly 1 for packaging a product comprises a device forming a refill 10 and a cover assembly 100 delimiting an internal space E for receiving the device forming a refill 10.

30 The device forming a refill 10 comprises a container 2, 3 or vial or reservoir delimiting an internal volume V intended to contain a product, notably a cosmetic product, and a closure element 4, shown in Figures 4 and 5 in the position in which it closes off the container 2, 3.

A “product” is understood to be a fluid or semi-fluid product, for example a care or make-up product, in particular for making up the lips, or a product for caring for or making up the epidermis of a user.

Such a device forming a refill 10 is intended to be combined with the cover assembly 100 so as to form the refillable assembly 1 for packaging a cosmetic product, and to be replaceable at the end of its life by a new device forming a refill, as will be described in more detail below.

5 As shown, and in an entirely non-limiting manner, the refillable assembly 1 for packaging a product comprises a covering and gripping cap 8, 9 for the device forming a refill 10.

10 In the exemplary embodiment shown in the figures, the device forming a refill 10 comprises a main body 2 extending along the longitudinal axis X-X' and an associated element 3, attached to the main body 2 and defining a neck 30 and a shoulder 31 of the container 2, 3.

As a variant, it is possible to provide for the main body 2 and the associated element 3 to form a single piece.

15 As shown in detail in Figures 1 to 7, the main body 2 of the container is provided with a closed lower end forming a bottom 20 and with an open upper end 22, opposite the lower end 20, provided with an opening O allowing access to the internal volume V for receiving the product.

Furthermore, and as can be seen in particular in Figure 2, the neck 30 of the device forming a refill 10 is provided with a radially outer screw thread 32.

20 In the embodiment illustrated, the associated element 3 is attached at the open end 22 of the main body 2.

In general, the device forming a refill 10 comprises a side wall 21, 33 extending between the bottom 20 and the neck 30 and connected to the latter via the shoulder 31.

25 A "shoulder" means any surface substantially normal to the axis of elevation of a cylindrical part, in this case the longitudinal axis X-X' of the vial, resulting from a sudden change in diameter, or more generally in a dimension in the radial direction, orthogonal to the longitudinal axis X-X'.

30 The open end 22 is connected to the bottom 20 by a recess 23 extending radially inwards and a groove 24 located axially between the recess 23 and the open end 22.

The associated element 3 comprises a sealing skirt 34 mounted through the open end 22 in the main body 2 and an attachment skirt 36 extending radially around

the sealing skirt 34. The attachment skirt 36 forms the side wall 33 of the associated element 3.

5 The attachment skirt 36 is connected to the neck 30 by means of the shoulder 31 and defines, with the sealing skirt 34, an annular space for receiving the portion of the main body 2 extending between the recess 23 and the open end 22.

10 In the embodiment illustrated, the associated element 3 is attached and rigidly secured to the main body 2, in translation along and in rotation about the longitudinal axis X-X', by the interaction of the groove 24, which is notably discontinuous in the circumferential direction, in other words formed of a plurality of cavities separated from one another in the circumferential direction, and gadrooning 35, which is notably discontinuous in the circumferential direction, in other words formed of a plurality of bosses separated from one another in the circumferential direction and received in the corresponding cavities of the groove 24.

15 However, those skilled in the art may envisage other solutions for rigidly securing the associated element 3 to the main body 2 in translation along and in rotation about the longitudinal axis X-X', such as the interaction of a groove which is continuous in the circumferential direction, provided on the main body 2, and gadrooning which is continuous in the circumferential direction, provided on the associated element 3 so as to ensure axial retention of the associated element 3 on the main body 2, combined with the interaction of at least one, and preferably a plurality of axial furrows, provided on the main body 2 and regularly distributed around the longitudinal axis X-X', and at least one, and preferably a plurality of axial ribs provided on the associated element 3 so as to ensure rotational coupling, about the longitudinal axis X-X', of the associated element 3 and of the main body 2. Such axial furrows and axial ribs may in particular together form a spline system for ensuring rotational coupling, about the longitudinal axis X-X', of the associated element 3 and of the main body 2.

20 Furthermore, in the embodiment illustrated in the figures, the side wall of the container is defined by the side wall 21 of the main body 2 located between the bottom 20 and the recess 23, and by the attachment skirt 36 of the associated element 3. Preferably, the recess 23 and the attachment skirt 36 are dimensioned such that the outer surface of the side wall 21 of the main body 2 located between the bottom 20 and the recess 23 is flush with the outer surface of the attachment skirt 36 when the associated element 3 is attached to the main body 2.

As shown, the attachment skirt 36 comprises an external snap-fitting bead or rib 37 protruding radially outwards from the outer surface of said skirt 36.

5 The external snap-fitting bead 37 may be continuous or discontinuous and is configured to interact with an internal snap-fitting element 126 of the cover assembly 100.

The device forming a refill 10 according to the invention further comprises a closure element 4 for the container 2, 3.

10 As can be seen in particular in Figures 2 to 7 and 9, the closure element 4 has a plate 40 extending transversely to the opening O of the neck 30 when the closure element 4 closes off the container 2, 3, as shown in these figures.

The closure element 4 also has an attachment skirt 41 extending from the plate 40, provided with a radially inner screw thread 42, adapted to interact with the outer screw thread 32 of the neck 30 when the closure element 4 closes off the container 2, 3.

15 As can be seen in particular in Figures 2 to 7, the attachment skirt 41 of the closure element 4 has an end edge 43 facing the shoulder 31 along the longitudinal axis X-X' when the closure element 4 closes off the container 2, 3.

20 The closure element 4 further has a sealing skirt 46 extending radially on the inside of the attachment skirt 41, and coaxial therewith and adapted to interact with the inner wall of the neck 30 of the container 2, 3 so as to seal the device forming a refill 10 according to the invention when the closure element 4 closes off the container 2, 3.

25 In the embodiment illustrated in the figures, and in an entirely non-limiting manner, the closure element 4 belongs to a sub-assembly for applying a cosmetic product, also referred to as a dipping applicator, further comprising an applicator member 6 extending inside the internal volume V of the container 2, 3 when the closure element 4 closes off the container 2, 3, and a stem 5 connecting the closure element 4 and the applicator member 6. Such an applicator sub-assembly is especially intended for the precise application, using the applicator member 6, of a cosmetic product
30 relatively small dimensions, such as the application of a product for making up keratin fibres, in particular the eyelashes and/or eyebrows, such as a mascara, a product for making up the lips, such as a lipstick or a gloss, or a product for making up the skin, such as a concealer, applied to localized areas of the face.

For an optimal user experience, notably in terms of ergonomics and precise application, the applicator sub-assembly 4 is connected, removably, to the covering and gripping cap 8, 9, as will be described in greater detail below.

5 The closure element 4 has a central axis coinciding with the longitudinal axis X-X' of the container 2, 3 when the closure element 4 closes off the latter and comprises means for rigidly securing in translation along the central axis and means for rigidly securing in rotation about the central axis to a covering and gripping cap 8, 9.

10 As can be seen in particular in Figures 2 to 7, in the embodiment illustrated, the means for rigidly securing in translation along the central axis comprise a groove 44 formed on a radially outer surface of the attachment skirt 41 of the closure element 4. This groove 44, which is for example continuous in the circumferential direction, is adapted to receive gadrooning 94, which is continuous or preferably discontinuous in the circumferential direction, formed on a radially inner surface of the covering and gripping cap 8, 9.

15 Furthermore, and as can be seen in particular in Figures 4 to 7, the means for rigidly securing in rotation about the central axis comprise a housing 45 of non-circular cross section formed on the plate 40 of the closure element 4. As can be seen in these Figures 2 to 7, the housing 45 has a flat area so as to define a non-circular cross section. This housing 45 of non-circular cross section is adapted to receive a peg 95 of complementary cross section provided on the covering and gripping cap 8, 9.

20 The covering and gripping cap 8, 9 defines a housing L for receiving the closure element 4.

25 The covering and gripping cap 8, 9 has a bottom 80, a peripheral wall 81 extending from the bottom 80 and an end edge 93 at least partially facing the shoulder 31 of the container 2, 3 along the longitudinal axis X-X' when the covering and gripping cap 8, 9 receives inside it the closure element 4 closing off the container 2, 3.

30 The covering and gripping cap 8, 9 has means for rigidly securing in translation along the central axis of the closure element and complementary means for rigidly securing in rotation about the central axis of the closure element 4, adapted to interact with complementary means provided on the closure element 4 so as to rigidly secure in rotation and in translation the closure element 4 and the covering and gripping cap 4 about the central axis.

In the embodiment illustrated in the figures, the covering and gripping cap is made in two parts and comprises an inner element, in this case forming a stem-holder 9, and an outer element, in this case forming a cover tube 8, housing the inner element 9 and rigidly secured thereto.

5 The inner element 9 comprises an outer cylindrical surface 9a in contact with an inner cylindrical surface 8a of the outer element 8.

The inner element 9 is attached inside the outer element 8 for example by clamping and/or by inserting a layer of adhesive.

10 As shown in Figure 5, in an entirely non-limiting manner, the inner cylindrical surface 8a of the outer element 8 comprises a plurality of parallel longitudinal striations or splines 8b delimiting between them longitudinal ribs configured to deform upon insertion of the inner element 9 in the outer element 8 and ensure the attachment by clamping of the inner element 9 relative to the outer element 8.

15 As a variant, provision could be made for the outer cylindrical surface 9a of the inner element 9 to have a plurality of splines or longitudinal striations or for both the inner element 8 and the outer element 9 to have such splines.

20 As can be seen in Figures 4 to 7, the inner element 9 of the covering and gripping cap has gadrooning 94 formed on its radially inner surface and received inside the groove 44 of the closure element 4 so as to ensure the axial retention, along the central axis, of the covering and gripping cap 8, 9 on the closure element 4, the groove 44 and the gadrooning 94 forming the complementary means for rigidly securing in translation, along the central axis, the covering and gripping cap 8, 9 and the closure element 4.

25 Furthermore, and as can be seen in Figures 4 to 7, the inner element 9 of the covering and gripping cap has a peg 95 of complementary cross section to the housing 45 of non-circular cross section provided on the plate 40 of the closure element 4. When the covering and gripping cap 8, 9 is put in place on the closure element 4, the peg 95 is inserted in the housing 45 and forms therewith the complementary means for rigidly securing in rotation, about the central axis, the covering and gripping cap 8, 9 and the closure element 4.

30

The cover assembly 100 comprises a cover case 101 and a support or mounting yoke 102, attached to the cover case 101 and defining a neck 103 and a shoulder 104 of the cover assembly 100.

As a variant, it is possible to provide for the cover case 101 and the mounting yoke 102 to form a single piece.

As shown in detail in Figures 2 to 7, the cover case 101 is provided with a closed lower end forming a bottom 110 and with an open upper end 112, opposite the lower end 110, provided with an opening O2 allowing access to an internal space E for receiving the container 2, 3.

The bottom 20 of the device forming a refill 10 is, in this case, axially spaced apart from the bottom 110 of the cover assembly 100.

In the embodiment illustrated, the mounting yoke 102 is attached at the open end 112 of the cover case 101.

In general, the cover assembly 100 comprises a peripheral side wall 111, 121 extending between the bottom 110 and the neck 103 and connected to the latter via the shoulder 104.

The open end 112 is connected to the bottom 110 by the peripheral wall 111. The peripheral wall 111 of the case 101 comprises, on its inner surface, an axial furrow 113 extending axially from the open end 112 and intended to interact with a radial flange 122 provided at the lower end of the mounting yoke 102.

The mounting yoke 102 is attached to the cover case 101 by any suitable means, for example, by adhesive bonding, screwing or by snap-fitting.

As can be seen in detail in Figures 2 to 7, the peripheral wall 121 of the mounting yoke 102 is discontinuous and comprises a plurality of flexible tabs 123 extending axially from the radial flange 122 and spaced apart from one another in the circumferential direction.

As a variant, it is possible to provide for the peripheral wall 121 of the mounting yoke 102 to have only one flexible tab 123.

In the example shown in Figure 2A, the peripheral wall 121 of the mounting yoke 102 comprises two groups of three flexible tabs 123a, 123b, the tabs 123 of each group 123a, 123b being spaced apart by a first circumferential clearance J1 and the two groups being spaced apart from one another by a second circumferential clearance J2. The first circumferential clearance J1 is smaller than the second circumferential clearance J2.

For example, the second circumferential clearance J2 is comprised between the angular extent of a flexible tab and the angular extent of a flexible tab plus two first circumferential clearances J1.

As a variant, it is possible to provide for the peripheral wall 121 to comprise at least three flexible tabs spaced apart from one another circumferentially, preferably regularly.

5 As shown, each flexible tab of each group of tabs comprises an external snap-fitting element 124, in this case a bead protruding radially outwards, delimiting with the radial flange 122 a snap-fitting groove 125 intended to interact with a radial rib 151 provided on an axial holding ring 105.

10 In general, at least one flexible tab 123 of the mounting yoke 102 comprises an external snap-fitting element 124, 125 intended to interact with a complementary snap-fitting element 151, in this case a radial rib, discontinuous or continuous, provided on the axial holding ring 105 so as to axially rigidly secure said ring 105 to the cover assembly 100.

15 In the example shown, an external snap-fitting element 124 extends in each of the second circumferential clearances J2. As a variant, it is possible to provide for the second circumferential clearances J2 to be without any flexible tab or external or internal snap-fitting element.

20 As shown, two of the flexible tabs of each group of tabs comprise, at their upper free end, an internal snap-fitting element 126, in this case an internal bead protruding radially inwards, intended to be housed behind the complementary external snap-fitting bead or rib 37 provided on the associated element 3, notably on the attachment skirt 36.

The internal snap-fitting elements 126 are regularly distributed circumferentially.

25 It is possible for the internal snap-fitting elements 126 to be provided on the same flexible tabs as those bearing the external snap-fitting elements 124, 125, or otherwise.

30 In general, at least one flexible tab 123 of the mounting yoke 102 comprises an internal snap-fitting element 126 intended to interact with a complementary external snap-fitting element 37 provided on the associated element 3 so as to axially retain said associated element 3 on the cover assembly 100.

In other words, the refillable packaging assembly 1 comprises a device for axial retention of the container forming a refill 2, 3 relative to the cover assembly 100 using at least one internal snap-fitting element 126 borne by a flexible tab 123 of the

cover assembly 100 and a complementary external snap-fitting element 37 borne by the container 2, 3.

5 Preferably, the refillable packaging assembly 1 comprises a device for axial retention of the container forming a refill 2, 3 relative to the cover assembly 100 using at least two internal snap-fitting elements 126 each borne by a flexible tab 123 of the cover assembly 100 and one or more complementary external snap-fitting elements 37 borne by the container 2, 3.

10 The complementary external snap-fitting elements 37 borne by the container 2, 3 are in this case snap-fitting beads, regularly distributed circumferentially around the cover assembly 100 and separated by circumferential spaces.

15 The snap-fitting tabs 123 extend axially from the radial flange 122 and are flexible in the radial direction, in other words capable of deforming radially elastically under the action of an external stress, in this case the passage of a complementary snap-fitting element 37 provided on the associated element 3 as a result of a removal force applied on the device forming a refill 2, 3 and tending to remove it from the cover assembly 100, and of returning to its initial position after the cessation of the external stress.

The axial retention device makes it possible to ensure axial retention of the container 2, 3 relative to the cover assembly 100.

20 The associated element 3 further comprises a rotation blocking element, in this case two axial tabs 38 extending axially downwards from the shoulder 31 and extending over an angular extent less than or equal to the angular extent of the second circumferential clearance J2 of the mounting yoke 102 so as to be inserted circumferentially in said second clearance J2 and block rotation of the associated element 3 relative to the mounting yoke 102 and thus to the cover assembly 100.

25 In the embodiment illustrated, the associated element 3 is attached and rigidly secured to the mounting yoke 102, in translation along and in rotation about the longitudinal axis X-X', by the interaction of the external snap-fitting beads 37 and internal snap-fitting beads 126, and by the interaction of the axial tabs 38 each with the tabs 123 defining the second circumferential clearance J2.

30 In the exemplary embodiment shown, the packaging assembly 1 comprises a device for locking/unlocking the device for axial retention of the container 2, 3 relative to the cover assembly 100.

As a variant, it is possible to provide for the refillable packaging assembly 1 to be without such a locking/unlocking device.

5 The locking/unlocking device uses the axial holding ring 105, rigidly secured axially to the cover assembly 100 and comprising, in this case, radial protrusions 152, in this case four in number, extending radially inwards, and regularly spaced apart from one another circumferentially.

In general, the axial holding ring 105 comprises at least one radial protrusion 152.

10 The axial holding ring 105 is rotatable relative to said assembly 100 between a locked position, in which each radial protrusion 152 is radially behind a flexible tab 126 provided with an internal snap-fitting element 126 so as to block radial bending thereof and thus prevent manual removal of the container 2, 3 from the cover assembly 100, and an unlocked position, in which the radial protrusions 152 are angularly offset from the flexible tabs 123 provided with an internal snap-fitting element 126 so as to allow them to bend radially and thus allow manual removal of the container 2, 3 from the cover assembly 100 by virtue of an axial removal force applied on said container 2, 3, causing the flexible tabs 123 provided with an internal snap-fitting element 126 to move away radially.

15 As a variant, a different number of radial protrusions 152 of the axial holding ring 105 could be provided. In general, the number of radial protrusions 152 of the axial holding ring 105 corresponds to the number of flexible tabs 123 provided with an internal snap-fitting element 126.

20 As shown in detail in Figures 8A and 8B, the axial holding ring 105 comprises an outer wall 153, in this case of polygonal section, and an inner wall 154 of circular section.

25 As a variant, other shapes could be envisaged for the section of the outer wall 153 of the axial holding ring 105, such as circular, ovoid, oblong, polygonal, for example square or rectangular, especially with rounded corners, or another shape.

30 The section of the outer wall 153 of the axial holding ring 105 may be identical and have the same dimension as the section of the cover case 101 so as not to form radial protuberances.

Conversely, and as shown, the section of the outer wall 153 of the axial holding ring 105 may be different and/or have a dimension different to the section of the cover case 101, so as to form one or more radial protuberances on the axial holding

ring 105 protruding from the cover case 101, for the purpose of facilitating gripping and actuation of the axial holding ring 105.

As shown, the axial holding ring 105 comprises, on its inner wall 154, radial ribs 151, in this case four in number, extending radially inwards, and regularly spaced apart from one another circumferentially.

In general, the axial holding ring 105 comprises at least one radial rib 151.

As shown, the axial holding ring 105 further comprises, on its inner wall 154, two axial ribs 155 extending axially at least over a part of the height of the axial holding ring 105.

The two axial ribs 155 are, in this case, located circumferentially opposite one another.

An axial rib 155 is circumferentially located between two radial protrusions 152.

Each axial rib 155 is intended to be inserted in the first circumferential clearance J1 between two flexible tabs 123 and form a device for indicating by touch and/or sound that the ring 105 is in position, notably in the locked position.

The axial ribs 155 have in this case a semi-circular section so that the flexible tabs 123 can easily get past them upon rotation of the ring 105.

In general, the axial holding ring 105 comprises, on its inner wall 154, at least one axial rib 155 extending axially at least over a part of the height of the axial holding ring 105.

As shown, the axial holding ring 105 comprises, on its inner wall 154, two circumferential stops 156 extending radially inwards.

The two circumferential stops 156 are, in this case, located circumferentially opposite one another.

A circumferential stop 156 is circumferentially located between two radial protrusions 152.

Each circumferential stop 156 is intended to be inserted in the second circumferential clearance J2 and to come into circumferential abutment against a flexible tab 123 and form a circumferential stop device in the locked position.

The circumferential stops 156 and the axial ribs 155 are arranged alternating and regularly spaced apart from one another.

In general, the axial holding ring 105 comprises, on its inner wall 154, at least one circumferential stop 156 extending radially inwards.

A disengageable anti-opening device fitted to the refillable assembly for packaging a cosmetic product according to the invention will now be described, with particular reference to Figures 10 to 13.

5 As can be seen in particular in Figures 10 to 13, the shoulder 31 of the container 2, 3, and in this case of the associated element 3, also has a stop surface 314, and preferably two stop surfaces 314 which are diametrically opposite with central symmetry about the longitudinal axis X-X', extending in a plane containing the longitudinal axis X-X'. As will be explained below, this or these stop surfaces 314 are adapted to interact with one or more stop surfaces 450 provided on the closure element 4 so as to define an end of screwing travel of the closure element 4 on the neck 30 of the container 2, 3, corresponding to the position in which the closure element 4 closes off the container 2, 3.

10 As can be seen in these figures, the disengageable anti-opening device is arranged between the neck 30 of the container 2, 3 and the closure element 4 and is adapted to block rotation of the closure element 4 relative to the neck 30 of the container 2, 3 in a direction of unscrewing SD, when the closure element is in the position in which it closes off the container 2, 3.

15 More specifically, the disengageable anti-opening device comprises a tongue 310, and preferably two tongues 310 which are diametrically opposite with central symmetry about the longitudinal axis X-X', each having a first end 311 rigidly secured to the shoulder 31 of the container 2, 3 and a second free end 312.

20 The tongue or tongues 310 extend in the circumferential direction, with their second free end 312 located downstream of their first end 311 joined to the shoulder, in the direction of screwing SV of the closure element 4 on the neck 30 of the container 2, 3, and have the ability to bend in the direction defined by the longitudinal axis X-X'; in other words, the tongue or tongues 310 are flexible in the axial direction.

25 The disengageable anti-opening device fitted to the assembly for packaging a cosmetic product forming a refill according to the invention further comprises one, and preferably two, anti-unscrewing stop surfaces 440 which are diametrically opposite with central symmetry about the longitudinal axis X-X', provided on the closure element 4. These anti-unscrewing stop surfaces 440 provided on the closure element 4 are provided to interact with the tongues 310 provided on the neck 30 of the container 2, 3 so as to block rotation of the closure element 4 relative to the neck 30 of the container

2, 3 in a direction of unscrewing, when the closure element 4 is in the position in which it closes off the container 2, 3, as shown in Figures 9 and 13.

In the embodiment illustrated in the figures, the anti-unscrewing stop surface or surfaces 440 provided on the closure element 4 are defined by a respective indent 44 formed in the end edge 43 of the closure element 4.

Furthermore, the stop surface or surfaces provided on the closure element 4 are defined by a respective cut-out 47 formed in the end edge 43 of the closure element 4.

The refillable device 10 forming a refill is designed to be sold with the closure element 4 in the position in which it closes off the container 2, 3, as shown in Figures 9 and 13.

The fitting, by screwing, of the closure element 4 on the neck 30 of the container 2, 3, to close off the latter, as shown in Figures 10 to 12, is performed at the factory or packaging centre, after the internal volume V of the container 2, 3 has been filled with a cosmetic product.

More specifically, and as can be seen in Figures 10 to 12, when the closure element 4 is screwed on the neck 30 of the container 2, 3, by rotating the closure element 4 relative to the neck 30 of the container 2, 3 in a direction of screwing SV, the tongues 310 are adapted to bend in the axial direction towards the bottom 20 of the container 2, 3 by contact with the end edge 43 of the closure element 4.

Figure 10 depicts a first position of the closure element 4, in which the inner screw thread 42 begins to engage with the outer screw thread 32 of the neck 30 of the container 2, 3.

Starting from the position shown in Figure 10, a torque is applied for example to the closure element 4 so as to turn it relative to the neck 30 of the container 2, 3 in a direction of screwing SV.

During this movement of screwing the closure element 4 on the neck 30 of the vial 2, 3 in the direction of screwing SV, the end edge 43 of the closure element 4, axially facing the tongue 310, comes into contact with the second end 312 of each tongue 310 and exerts an axial force thereon in the direction of the bottom 20 of the container 2, 3, tending to cause the tongues 310 to bend elastically in this same direction, as shown in Figures 11 and 12. During this movement of screwing the closure element 4 on the neck 30 of the container 2, 3 in the direction of screwing SV,

the free ends 312 of the tongues slide against the end edge 43 of the closure element 4 in the circumferential direction.

Continuing this movement of screwing the closure element 4 on the neck 30 of the container 2, 3 in the direction of screwing SV, the indents 44 defining the anti-unscrewing stop surfaces 440 are gradually brought to face, in the circumferential direction, the free end 312 of the tongues 310, which have an anti-unscrewing stop surface 313, as can be seen in Figure 13.

When the closure element 4 approaches the end of screwing travel on the neck 30 of the container 2, 3, for example when stop surfaces 314, 450 provided respectively on the shoulder 31 of the container 2, 3 and on the closure element 4 are at a distance from one another in the circumferential direction by an angle of between 0.5° and 10° , the free end 312 of each tongue 310 is positioned facing the respective indent 44 and the contact between the free end 312 of each tongue 310 and the end edge 43 of the closure element 4 is broken. The tongues 310 then move into a blocking position, by elastic return in the axial direction, in such a way that the anti-unscrewing stop surface 313 provided on the free end 312 of each tongue 310 is facing, in the circumferential direction, the complementary anti-unscrewing stop surface 440 provided on the closure element 4, so as to block rotation of the closure element 4 relative to the neck 30 of the container 2, 3 in a direction of unscrewing SD when the closure element reaches the end of screwing travel on the neck of the vial, as shown in Figures 9 and 13.

For the above purposes, those skilled in the art will be able to adapt the design and notably define the dimensions and positions, in particular in the circumferential direction, of the outer screw thread 32 of the neck 30 of a container 2, 3, the inner screw thread 42 of the attachment skirt 41 of the closure element 4, the stop surfaces 314, 450 defining the end of screwing travel of the closure element 4 on the neck 30 of a container 2, 3, and the anti-unscrewing stop surfaces 313, 440 provided on the shoulder 31 of the container 2, 3 and on the closure element 4.

The device forming a refill 10 according to the invention is then in the configuration in which it will be sold, with the closure element 4 in the position in which it closes off the container 2, 3, and with the tongues 310 in the blocking position preventing rotation of the closure element 4 relative to the neck 30 of the container 2, 3 in a direction of unscrewing SD, in such a way as to prevent a user from using the device forming a refill 10 alone.

Thus, it is only when the closure element 4 is combined with a covering and gripping cap 8, 9 that the tongues 310 are placed in the unblocking position and unscrewing of the closure element 4 relative to the neck 30 of the container 2, 3 is allowed.

5 In the embodiment illustrated in Figures 2 to 13, the container forming a refill 10 takes the form of a vial, typically intended to contain the cosmetic product, and its closure element 4 is combined with a stem 5 the end of which is provided with an applicator member 6.

10 The embodiment illustrated in Figure 14, in which the same elements bear the same references, differs from the previous embodiment only in that the closure element 4 does not have an applicator member 6 and simply forms a lid for closing off the opening O of the device forming a refill 10.

15 The embodiment illustrated in Figures 15 to 17, in which the same elements bear the same references, differs from the embodiment illustrated in Figures 1 to 13 only in terms of the general shape of the packaging assembly 1 in which the device forming a refill 10 has, in this case, a hemi-spherical bottom 20 and the cover assembly 100 has in this case a cylindrical shape and by the fact that the cover assembly 100 does not comprise a cover case and a mounting yoke which are separate but they form, in this case, a single piece. The closure element 4 in this case simply forms a cylindrical
20 plug.

As shown, the refillable assembly 1 further comprises a covering ring 200 intended to radially surround the axial holding ring 105 so as to be flush with both the outer wall of the closure member 4 and the outer wall of the cover assembly 100.

25 As shown in detail in Figures 15 to 17, the cover assembly 100 is provided with a closed lower end forming a bottom 110 and with an open upper end 103, opposite the lower end 110, forming a neck and provided with an opening O2 allowing access to an internal space E for receiving the device forming a refill 10.

30 The cover assembly 100 comprises a peripheral side wall 121 extending between the bottom 110 and the neck 103 and connected to the latter via a radial flange 122 forming a shoulder 104.

The bottom 20 of the device forming a refill 10 is, in this case, axially spaced apart from the bottom 110 of the cover assembly 100.

As can be seen in detail in Figure 16, the peripheral wall 121 of the neck 103 is discontinuous and comprises a plurality of flexible tabs 123 extending axially from

the radial flange 122 and spaced apart from one another in the circumferential direction.

In the example shown in Figure 16, the peripheral wall 121 of the neck 103 comprises two groups of three flexible tabs 123a, 123b, the tabs 123 of each group 5 123a, 123b being spaced apart by a first circumferential clearance J1 and the two groups being spaced apart from one another by a second circumferential clearance J2. The first circumferential clearance J1 is smaller than the second circumferential clearance J2.

As shown, each flexible tab of each group of tabs comprises an external snap- 10 fitting element 124, in this case a bead protruding radially outwards, delimiting with the radial flange 122 a snap-fitting groove 125 intended to interact with a radial rib 151 provided on an axial holding ring 105.

As shown, two of the flexible tabs of each group of tabs comprise, at their 15 upper free end, an internal snap-fitting element 126, in this case an internal bead protruding radially inwards, intended to be housed behind the complementary external snap-fitting bead or rib 37 provided on the associated element 3, notably on the attachment skirt 36.

As shown in Figures 15 and 16 and in an entirely non-limiting manner, the 20 peripheral wall 121 of the cover assembly 100 has two circumferential through windows or openings 127, allowing the user to see part of the container of the device 10 forming a refill through the cover assembly 100 when it is received in the latter.

The two circumferential windows 127 are, in this case, located radially facing one another.

As a variant, just a single circumferential window 127 could be provided, 25 extending over an angular extent of between 10° and 90° , for example equal to 45° .

The present invention further proposes a method for refilling a refillable assembly 1 for packaging a cosmetic product according to one or other of the embodiments.

In this refilling method, the user has a refillable assembly 1 for packaging a 30 cosmetic product in which the refillable device 10 forming a refill is used up, in other words substantially emptied of its contents, and needs to be replaced with a new device 10' forming a refill.

Thus, in a first phase of this refilling method, visible in Figure 18A, the user removes/detaches the covering and gripping cap 8, 9 from the closure element belonging to the used device 10 forming a refill.

5 The removal of the covering and gripping cap 8, 9 from the closure element 4 is performed by relative separation of these two elements in the axial direction causing the gadrooning 94 borne by the covering and gripping cap 8, 9 to come out of the groove 44 provided on the closure element 4.

10 However, the prior step of removal of the covering and gripping cap 8, 9 is not necessary to be able to place the ring 105 in the position of unlocking of the device 10 forming a refill.

The user then rotates the axial holding ring 105 in a first direction of rotation R1, as can be seen in Figure 18B, until the radial protrusions 152 of said ring 105 are angularly offset from the flexible tabs 123 provided with internal snap-fitting elements 126 of the mounting yoke 102.

15 The user then takes the used device 10 forming a refill and applies an outward axial removal force so as to cause the flexible tabs 123 having the internal snap-fitting elements 126 of the mounting yoke 102 to move away under the effect of the corresponding complementary external snap-fitting elements 37 provided on the container 2, 3, so as to manually remove the container 2, 3 of the used device 10 forming a refill from the cover assembly 100, as can be seen in Figure 18C.

20 The user then takes a new device 10' forming a refill, the internal volume V of the container of which is filled with product, and inserts it in the space E of the cover assembly 100, visible in Figure 18D, until snap-fitting of the axial retention device formed by the interaction between the internal snap-fitting elements 126 of the mounting yoke 102 and the corresponding complementary external snap-fitting elements 37 provided on the container 2, 3 of the new device 10' forming a refill.

25 The user rotates the axial holding ring 105 in a second direction of rotation R2, opposite to the first direction of rotation R1, as can be seen in Figure 18E, until the radial protrusions 152 of said ring 105 are behind the flexible tabs 123 provided with internal snap-fitting elements 126 of the mounting yoke 102, thus locking the axial retention device in the snap-fitting position.

30 The user positions and attaches, on the new device forming a refill 10', the covering and gripping cap 8, 9 which was fitted on the used device 10 forming a refill.

However, this step of putting back on the covering and gripping cap 8, 9 after placing the ring 105 in the position of locking the new device 10' forming a refill is not strictly necessary.

5 In the assembly of the embodiments, the covering and gripping cap 8, 9, and the cover assembly 100 are, for example, made of plastic, notably a thermoplastic polymer such as for example polypropylene (PP), polyethylene (PET), or polybutylene terephthalate (PBT), or a recycled plastic. The covering and gripping cap 8, 9 and the cover assembly 100 are, preferably, made of the same plastic.

10 For example, the main body 2 and the associated element 3 of the refillable container are made of plastic, advantageously of the same material.

According to another variant, the main body 2 of the refillable container is made of drawn glass.

The axial holding ring 105 may be made of plastic, notably a thermoplastic polymer such as for example polypropylene (PP), or of metal, notably aluminium.

15 In the assembly of the embodiments, the axial holding ring 105 is not removable and stays rigidly secured axially to the cover assembly 100 even when the container 2, 3 of the device forming a refill 10 is removed.

20 Thanks to the various arrangements of the invention, the Applicant is able to offer its customers an assembly 1 for packaging a cosmetic product comprising a device forming a refill with improved axial retention and a minimalist structure, thereby reducing the environmental impact resulting from the manufacture of this refillable assembly, notably by limiting the raw materials used, from its packaging and transport, in particular by limiting the weight of the device forming a refill, or from its end of life treatment.

25 Furthermore, with a packaging assembly according to the invention, the Applicant can also maintain and guarantee an optimal experience in use as regards locking or unlocking the axial retention of the container forming a refill on the cover assembly.

CLAIMS

1. Refillable assembly (1) for packaging a product, notably a cosmetic product, extending axially along a longitudinal axis (X-X') and comprising at least:

5 - a device forming a refill (10) comprising a container (2, 3) delimiting an internal volume (V) intended to receive the product, and

 - a cover assembly (100) delimiting an internal space (E) for receiving the device forming a refill (10), characterized in that it comprises a device for axial retention of the container (2, 3) relative to the cover assembly (100) comprising:

10 - at least one flexible tab (123) extending axially along the longitudinal axis (X-X') of the refillable packaging assembly (1) and comprising an internal snap-fitting element (126); and

 - at least one complementary external snap-fitting element (37) borne by the container (2, 3) and intended to interact with the internal snap-fitting element (126) of the flexible tab (123) of the cover assembly (100) in a position of axial retention of the container (2, 3) relative to the cover assembly (100), the flexible tab (123) being elastically deformable in the radial direction between an initial position in which said flexible tab (123) extends axially along a first axis substantially parallel to the longitudinal axis (X-X') and a deformed position in which said flexible tab (123) extends along a second axis forming an angle with the longitudinal axis (X-X').

15 2. Refillable packaging assembly (1) according to Claim 1, wherein the device for axial retention of the container (2, 3) relative to the cover assembly (100) comprises at least two flexible tabs (123) distributed circumferentially around the cover assembly (100).

25 3. Refillable packaging assembly (1) according to Claim 1 or 2, further comprising a device for locking/unlocking the device for axial retention of the container (2, 3) relative to the cover assembly (100).

30 4. Refillable packaging assembly (1) according to Claim 3, wherein the locking/unlocking device comprises an axial holding ring (105), which is axially rigidly secured to the cover assembly (100) and comprises at least one radial protrusion (152) extending radially inwards, the axial holding ring (105) being rotatable about the longitudinal axis (X-X') relative to the cover assembly (100) between a locked position, in which the radial protrusion (152) is radially behind the flexible tab (123) provided with the internal snap-fitting element (126), and an unlocked position, in which the

radial protrusion (152) is angularly offset from the flexible tab (123) provided with the internal snap-fitting element (126).

5 5. Refillable packaging assembly (1) according to any one of the preceding claims, wherein the cover assembly (100) comprises a closed lower end forming a bottom (110), an open upper end (112), opposite the bottom (110), having a neck (103) and allowing access to the internal space (E) for receiving the container (2, 3), and a peripheral side wall (111, 121) extending between the bottom (110) and the open upper end (112).

10 6. Packaging assembly (1) according to Claim 5, wherein the flexible tab (123) is borne by the neck (103) of the cover assembly (100).

15 7. Refillable packaging assembly (1) according to Claim 5 or 6, wherein the neck (103) of the cover assembly (100) comprises two groups (123a, 123b) of three flexible tabs (123), said flexible tabs (123a, 123b) of each group being spaced apart by a first circumferential clearance (J1) and the two groups being spaced apart from one another by a second circumferential clearance (J2).

 8. Refillable packaging assembly (1) according to Claim 7, wherein the first circumferential clearance (J1) is smaller than or equal to the second circumferential clearance (J2).

20 9. Refillable packaging assembly (1) according to Claim 7 or 8, wherein at least one flexible tab (123) of each group (123a, 123b) of three flexible tabs (123) is provided with an internal snap-fitting element (126).

25 10. Refillable packaging assembly (1) according to Claim 9, wherein at least two flexible tabs (123) of each group (123a, 123b) of three flexible tabs (123) are each provided with an internal snap-fitting element (126) intended to be housed behind a complementary external snap-fitting element (37) provided on the container (2, 3).

 11. Refillable packaging assembly (1) according to Claim 10, wherein the internal snap-fitting element (126) borne by the flexible tab (123) is an internal bead protruding radially inwards, and the complementary external snap-fitting element (37) borne by the container (2, 3) is an external bead protruding radially outwards.

30 12. Refillable packaging assembly (1) according to Claim 4 in conjunction with any one of Claims 6 to 11, wherein the axial holding ring (105) comprises at least one radial rib (151) and the neck (103) of the cover assembly (100) comprises at least one external snap-fitting element (124, 125) intended to interact with said radial rib (151).

13. Refillable packaging assembly (1) according to Claims 6 to 11, wherein at least one flexible tab (123) of each group of flexible tabs (123a, 123b) comprises an external snap-fitting element (124, 125).

5 14. Refillable packaging assembly (1) according to Claim 13, wherein the external snap-fitting element (124, 125) comprises a bead (124) protruding radially outwards and a snap-fitting groove (125) located axially directly under said bead (124) and intended to interact with the radial rib (151) provided on the axial holding ring (105).

10 15. Refillable packaging assembly (1) according to Claim 4 in conjunction with any one of the preceding claims, wherein the axial holding ring (105) comprises, on its inner wall (154), at least one axial rib (155) extending axially at least over a part of the height of the axial holding ring (105).

15 16. Refillable packaging assembly (1) according to Claim 15 in conjunction with Claim 2, wherein the axial holding ring (105) comprises, on its inner wall (154), at least two axial ribs (155) extending axially at least over a part of the height of the axial holding ring (105) and intended to each be inserted between two flexible tabs (123) in the locked position of the ring (105).

20 17. Refillable packaging assembly (1) according to Claim 4 in conjunction with any one of the preceding claims, wherein the axial holding ring (105) comprises, on its inner wall (154), at least one circumferential stop (156) extending radially inwards and intended to come into circumferential abutment against the flexible tab (123) in the locked position of the ring (105).

25 18. Refillable packaging assembly (1) according to Claim 17 in conjunction with Claim 2, wherein the axial holding ring (105) comprises, on its inner wall (154), at least two circumferential stops (156) extending radially inwards and each intended to come into circumferential abutment against one of the flexible tabs (123) in the locked position of the ring (105).

30 19. Refillable packaging assembly (1) according to Claims 16 and 18, wherein the circumferential stops (156) and the axial ribs (155) are arranged alternating and spaced apart from one another circumferentially, preferably regularly.

20. Refillable assembly (1) according to any one of the preceding claims, wherein the container of the device forming a refill (10) comprises a main body (2) extending along the longitudinal axis (X-X') and an associated element (3), attached to the main body (2) and defining a neck (30) and a shoulder (31) of the container (2, 3).

21. Refillable assembly (1) according to any one of the preceding claims, wherein the cover assembly (100) comprises a cover case (101) and a mounting yoke (102), attached to the cover case (101) and defining the neck (103) of the cover assembly (100).

5 22. Refillable assembly (1) according to Claim 21, wherein the cover case (101) is provided with a closed lower end forming a bottom (110) and with an open upper end (112), opposite the lower end (110), the mounting yoke (102) being attached at the open end (112) of the cover case (101).

10 23. Refillable assembly (1) according to Claim 21 or 22, wherein the open end (112) is connected to the bottom (110) by a peripheral wall (111) of the cover assembly (100) and wherein said peripheral wall (111) comprises, on its inner surface, an axial furrow (113) extending axially from the open end (112) and intended to interact with a radial flange (122) provided at the lower end of the mounting yoke (102).

15 24. Refillable assembly (1) according to Claim 23, wherein the peripheral wall (121) of the mounting yoke (102) is discontinuous and comprises at least one flexible tab (123) extending axially from the radial flange (122).

20 25. Refillable assembly (1) according to Claim 2 in conjunction with any one of the preceding claims, wherein the container (2, 3) further comprises at least one rotation blocking element (38) intended to be inserted circumferentially between two flexible tabs (123) so as to block rotation of the container (2, 3) relative to the cover assembly (100).

25 26. Refillable assembly (1) according to any one of the preceding claims, wherein the device forming a refill (10) comprises a closure element (4) mounted on the container (2, 3) and closing off access to the internal volume (V).

25 27. Refillable assembly (1) according to any one of the preceding claims, further comprising a covering and gripping cap (8, 9) for the device forming a refill (10).

30 28. Method for refilling a refillable assembly (1) for packaging a cosmetic product according to any one of the preceding claims, comprising at least the following steps:

- applying an outward axial removal force on the container (2, 3), so as to cause the flexible tab (123) provided with an internal snap-fitting element (126) of the cover assembly (100) to move away under the effect of the complementary external

snap-fitting element (37) provided on the container (2, 3), so as to remove said container (2, 3) of the used device forming a refill (10) from the cover assembly (100);

- supplying a new device forming a refill (10'); and

5 - inserting and attaching said new device forming a refill (10') in the internal space (E) of the cover assembly (100), until snap-fitting of the axial retention device formed by the interaction between the internal snap-fitting element (126) of the cover assembly (100) and the complementary external snap-fitting element (37) provided on the container (2, 3).

29. Refilling method according to Claim 28, wherein the refillable assembly
10 (1) comprises an axial holding ring (105) rigidly secured axially to the cover assembly (100) and comprising at least one radial protrusion (151) extending radially inwards, said ring (105) being rotatable relative to the cover assembly (100), and wherein the method comprises, before the step of applying an axial removal force, a step consisting in:

15 - rotating the axial holding ring (105) in a first direction of rotation (R1) until the radial protrusion (151) of said ring (105) is angularly offset from the flexible tab (123) provided with an internal snap-fitting element (126) of the cover assembly (100); and comprising, after the step of inserting and attaching a new device forming a refill (10'), a step consisting in:

20 - rotating the axial holding ring (105) in a second direction of rotation (R2), opposite to the first direction of rotation (R1), until the radial protrusion (151) of said ring (105) is radially behind the flexible tab (123) provided with an internal snap-fitting element (126), thus locking the axial retention device in the axial retention position.

30. Refilling method according to Claim 29, wherein the refillable assembly
25 further comprises a covering and gripping cap (8, 9) for the device forming a refill (10), and wherein the method comprises, preferably before the step of rotating the axial holding ring (105) in the first direction of rotation (R1), a step consisting in removing a covering and gripping cap (8, 9) from a closure element (4) belonging to the used device forming a refill (10), and comprising, preferably after the step of rotating the
30 axial holding ring (105) in the second direction of rotation (R2), a step consisting in repositioning, on the new device forming a refill (10'), the covering and gripping cap (8, 9) which was fitted on the used device forming a refill (10).

[Fig. 1]

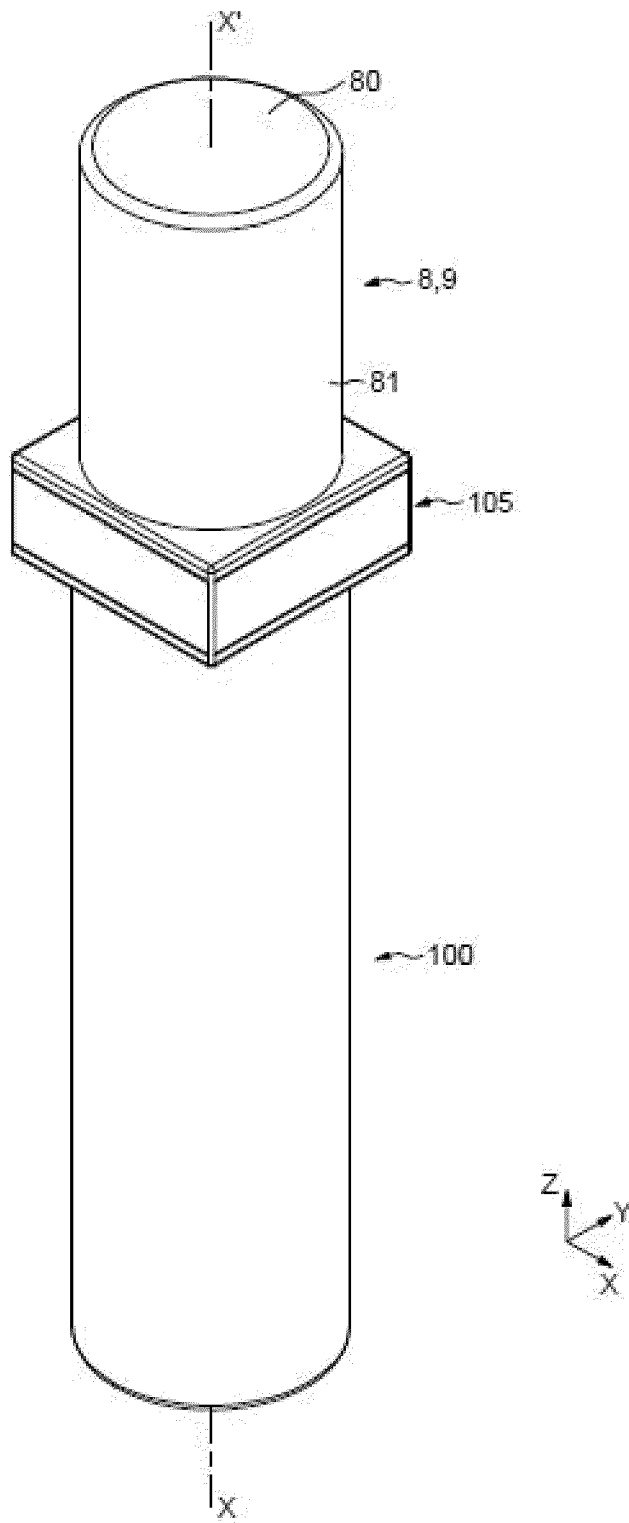

[Fig. 2]

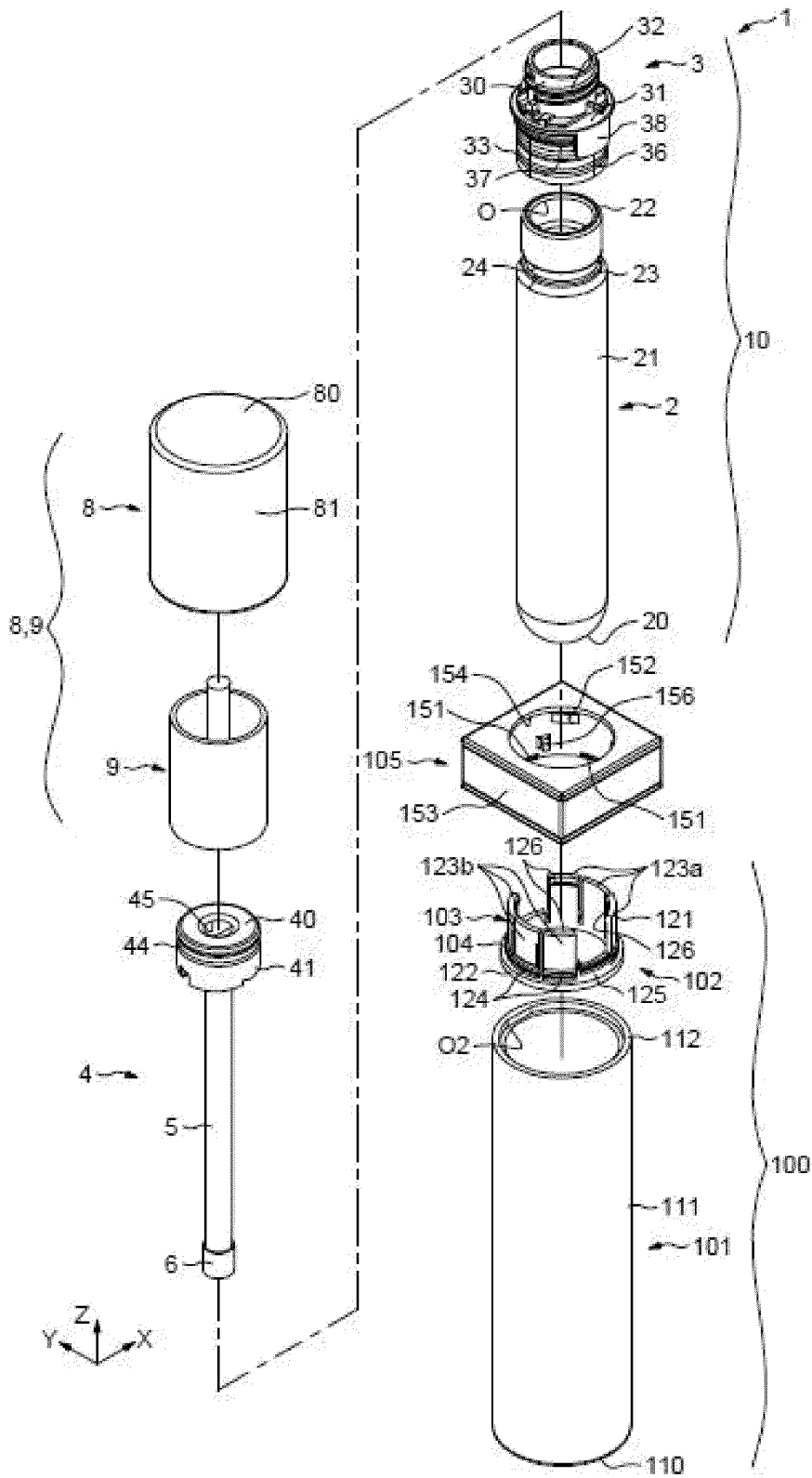

[Fig. 2A]

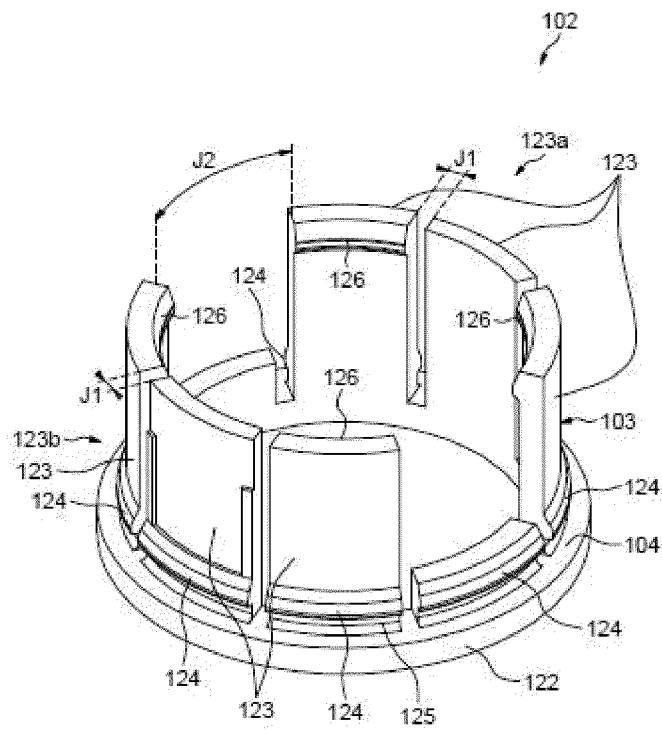

[Fig. 3]

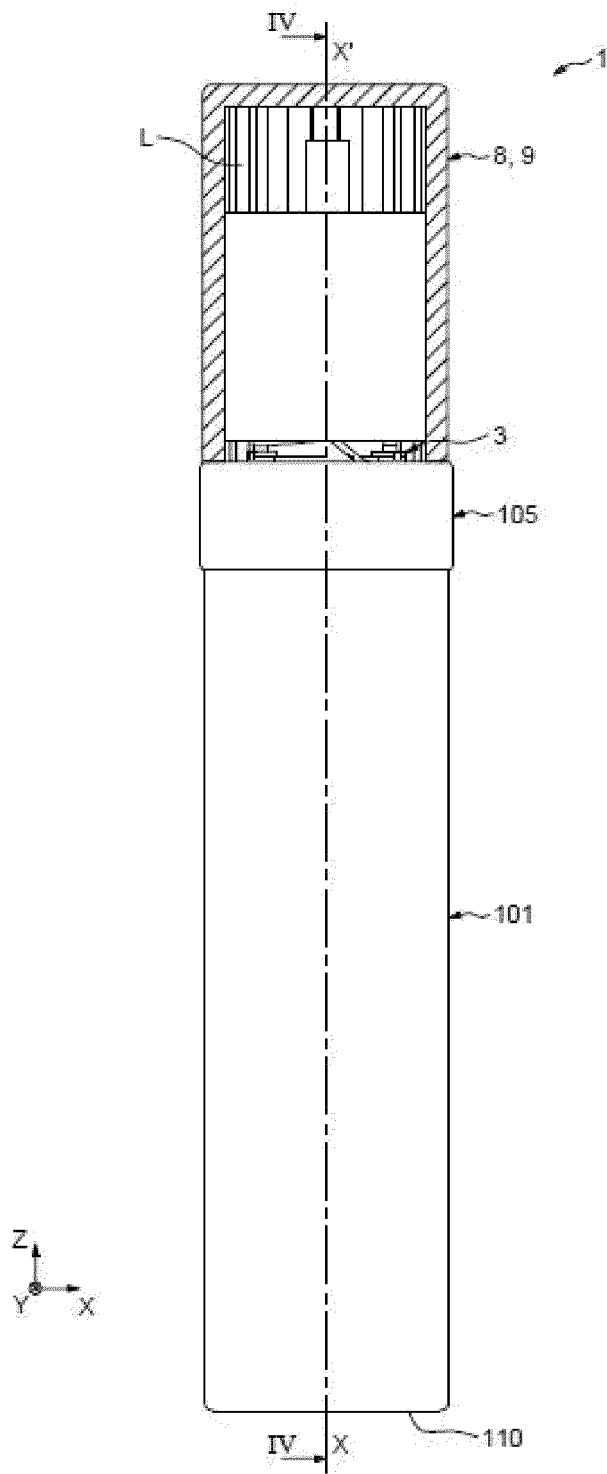

[Fig. 4]

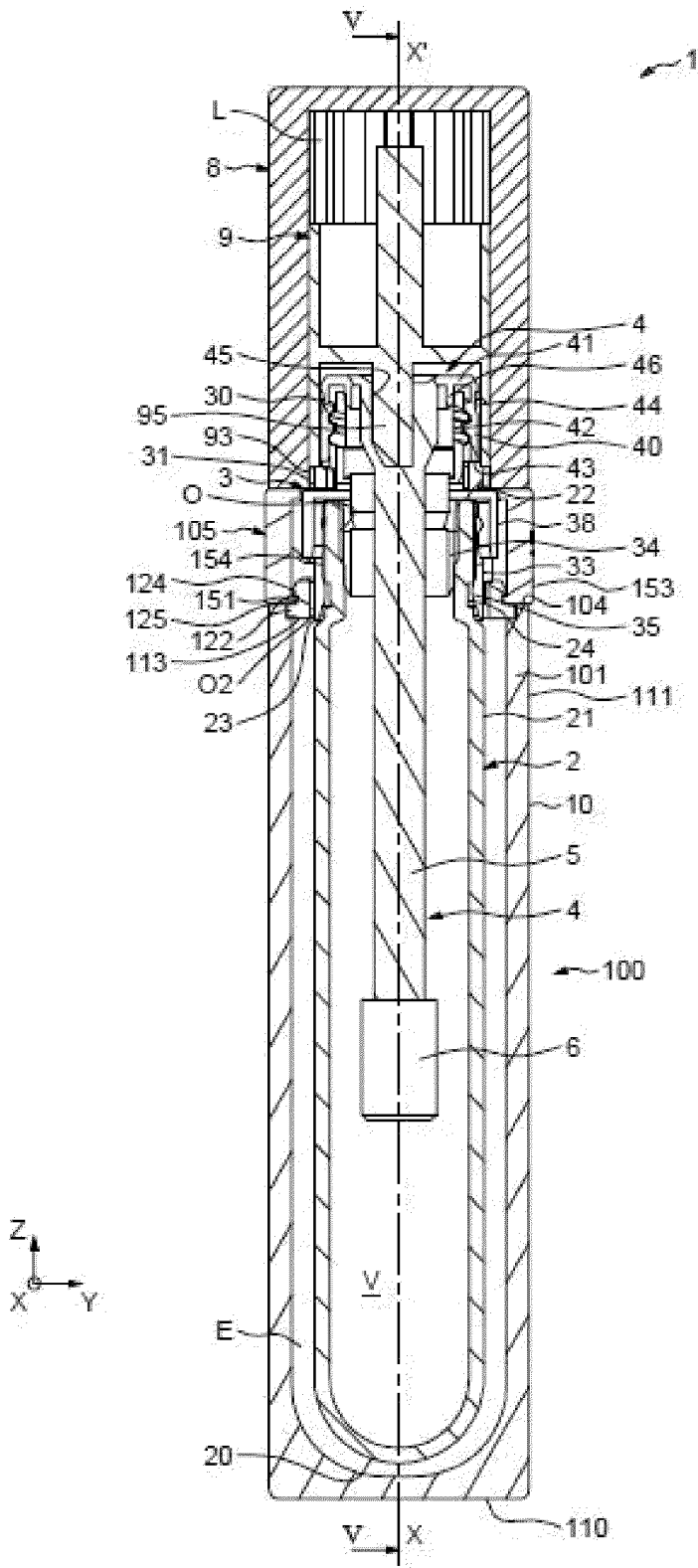

[Fig. 5]

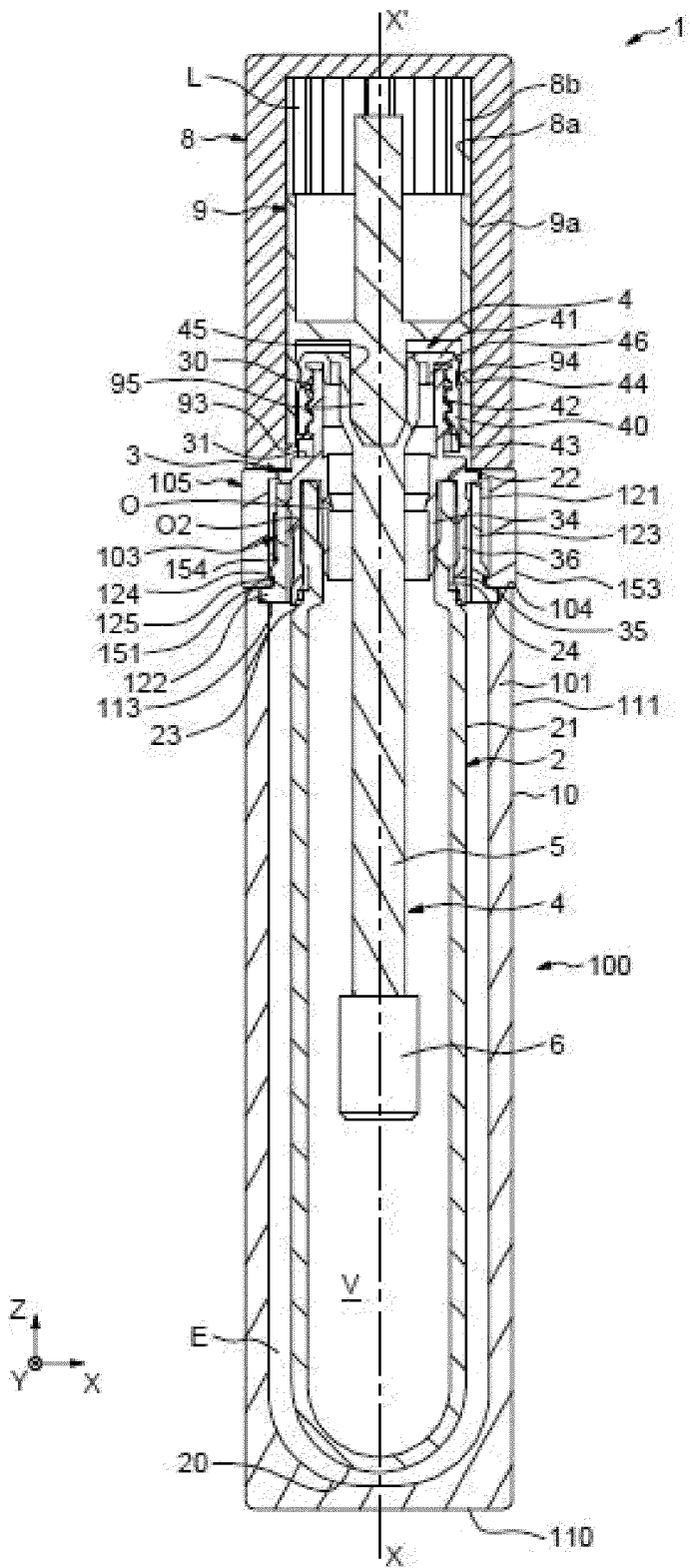

[Fig. 6]

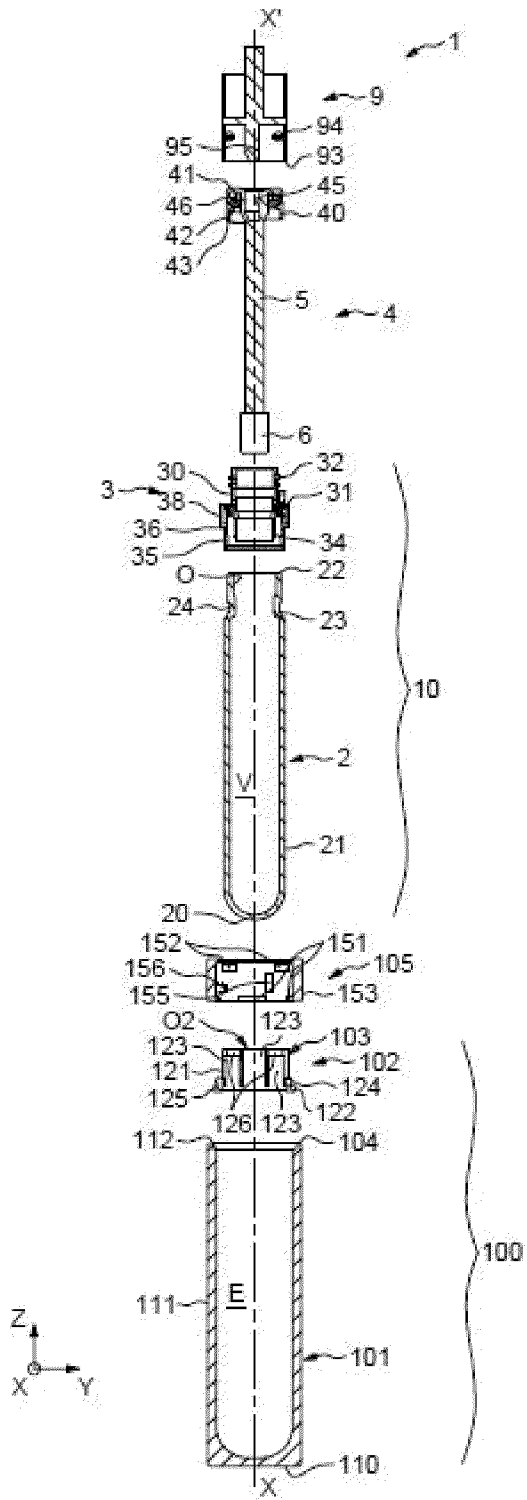

[Fig. 7]

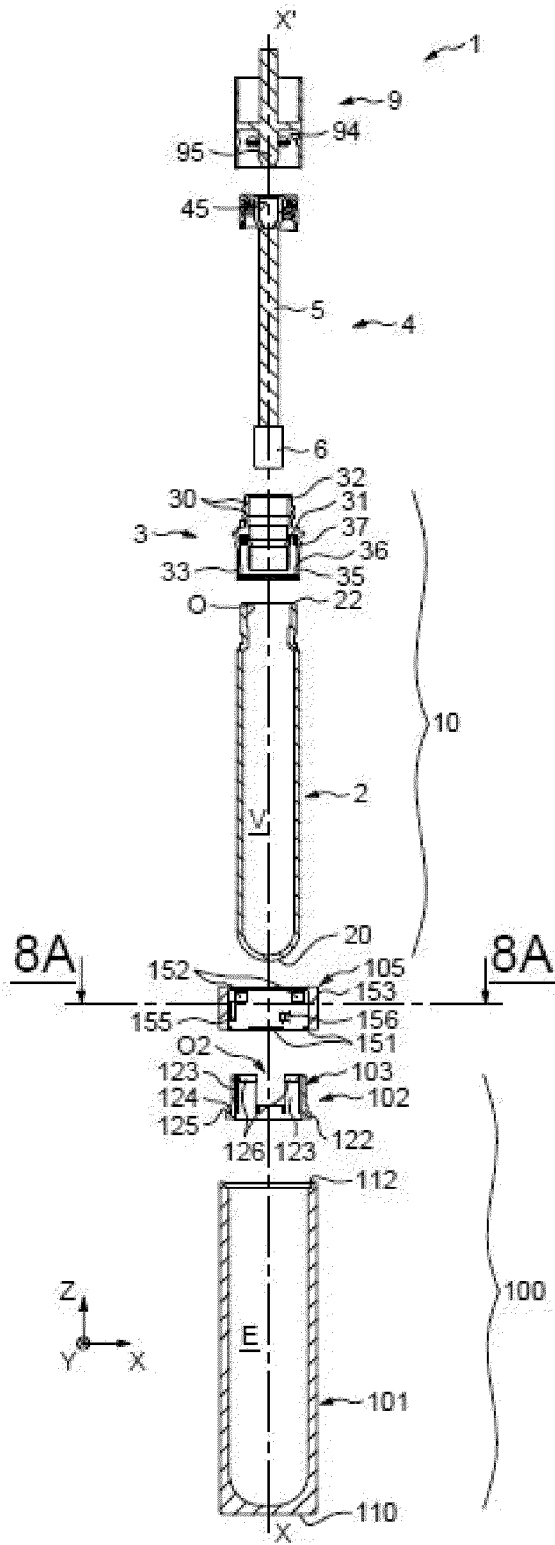

[Fig. 8A]

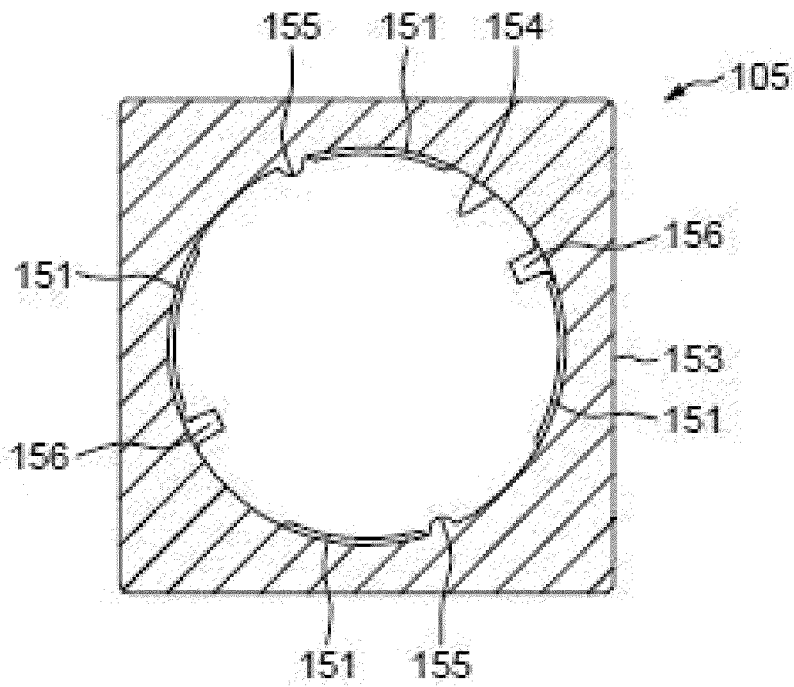

[Fig. 8B]

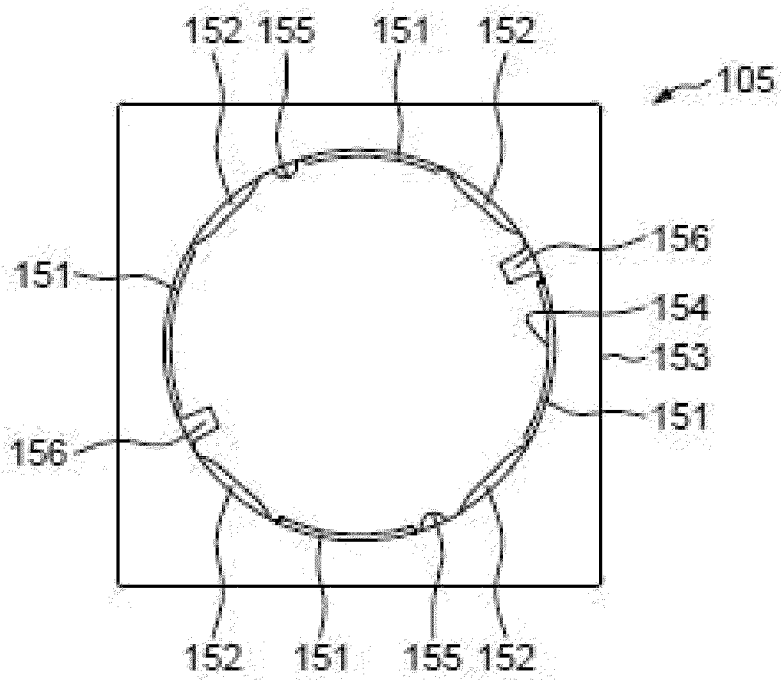

[Fig. 9]

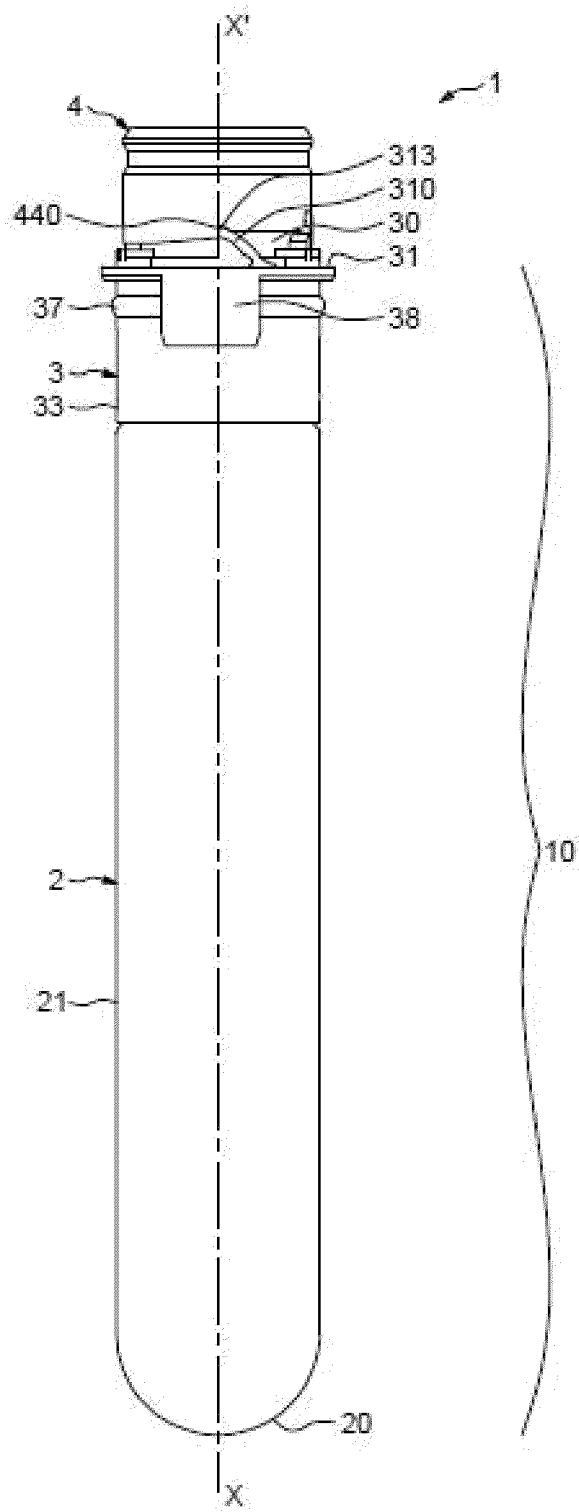

[Fig. 10]

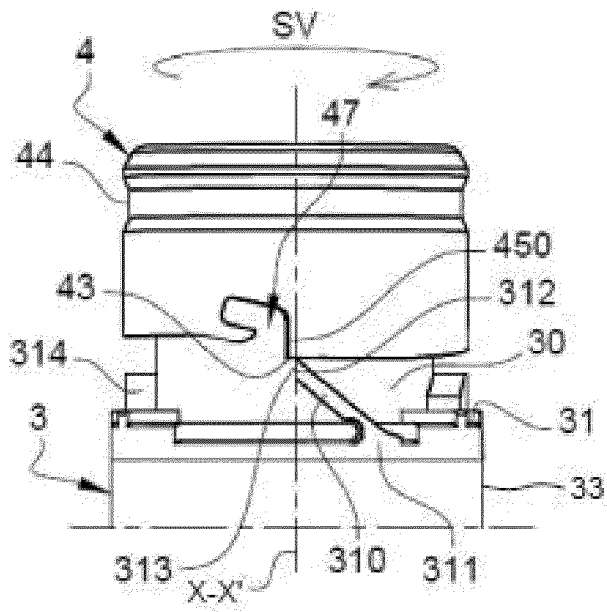

[Fig. 11]

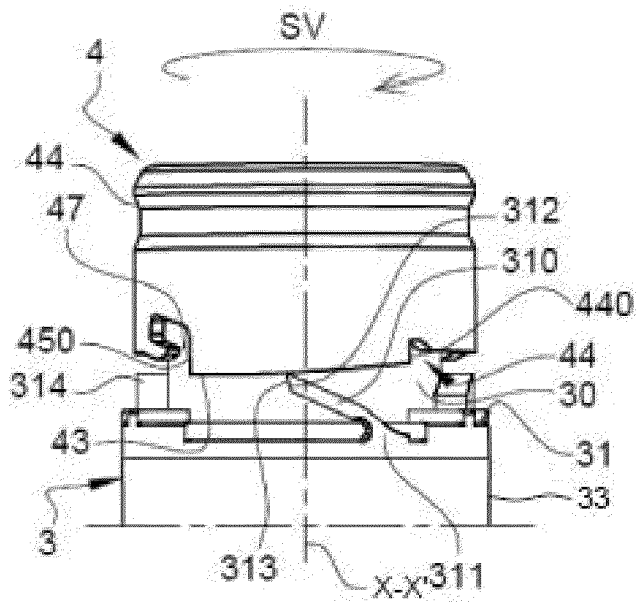

[Fig. 12]

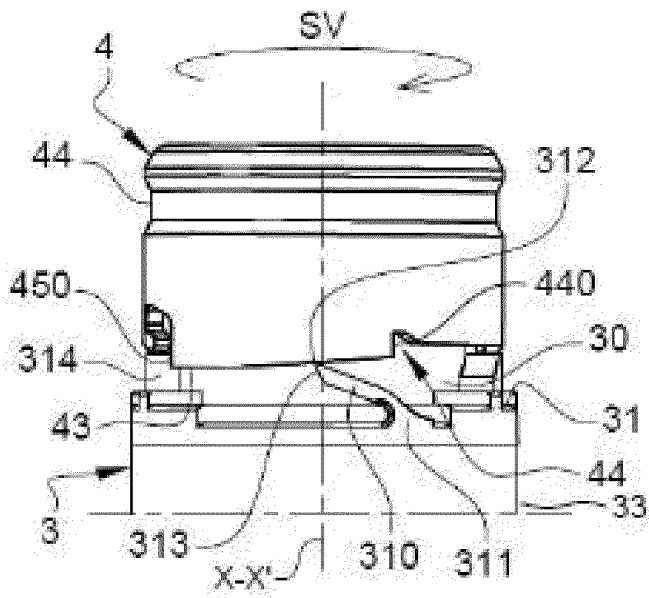

[Fig. 13]

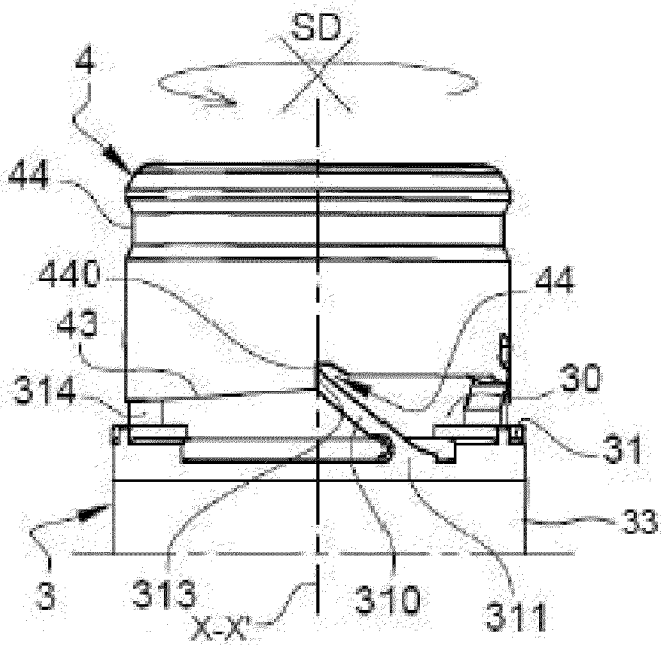

[Fig. 14]

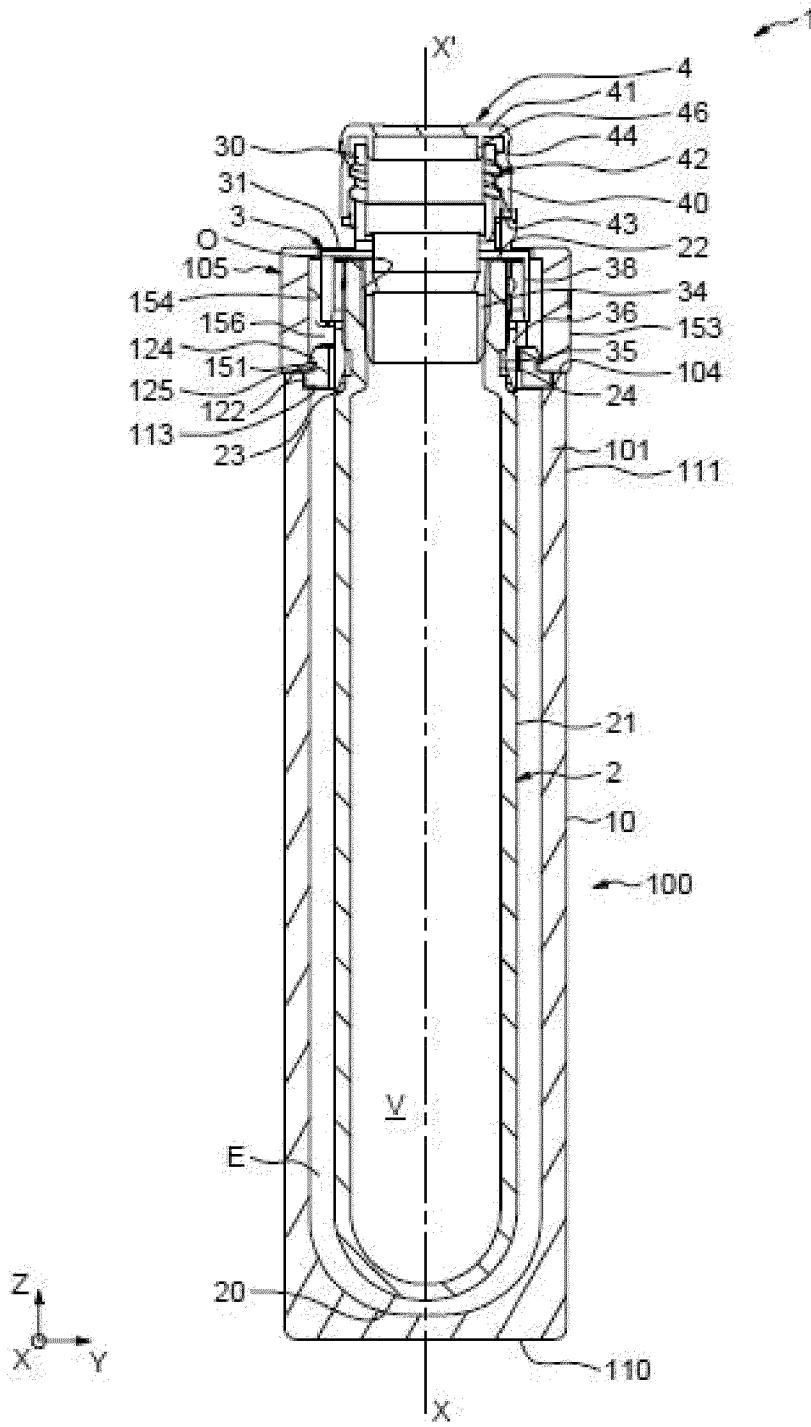

[Fig. 15]

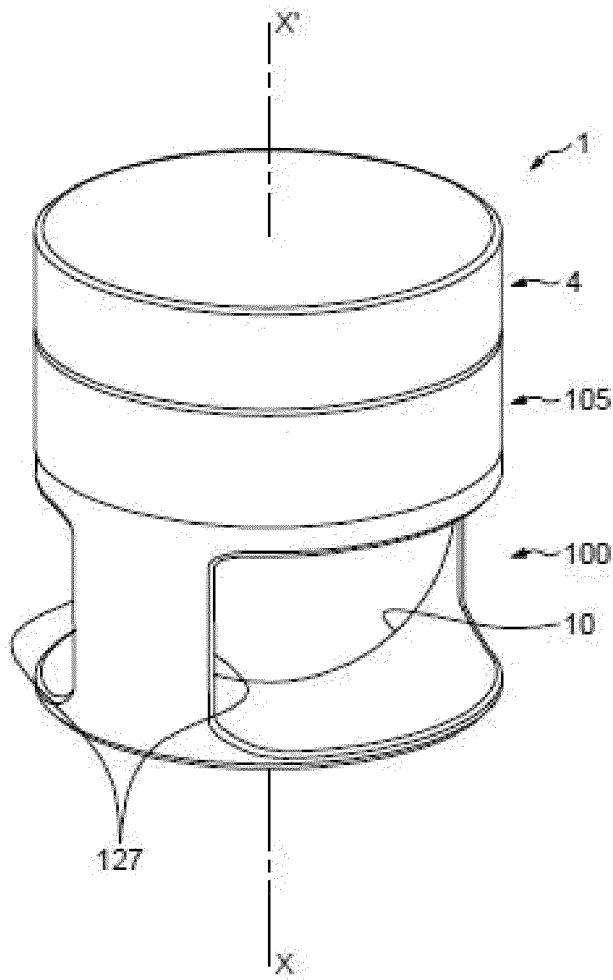

[Fig. 16]

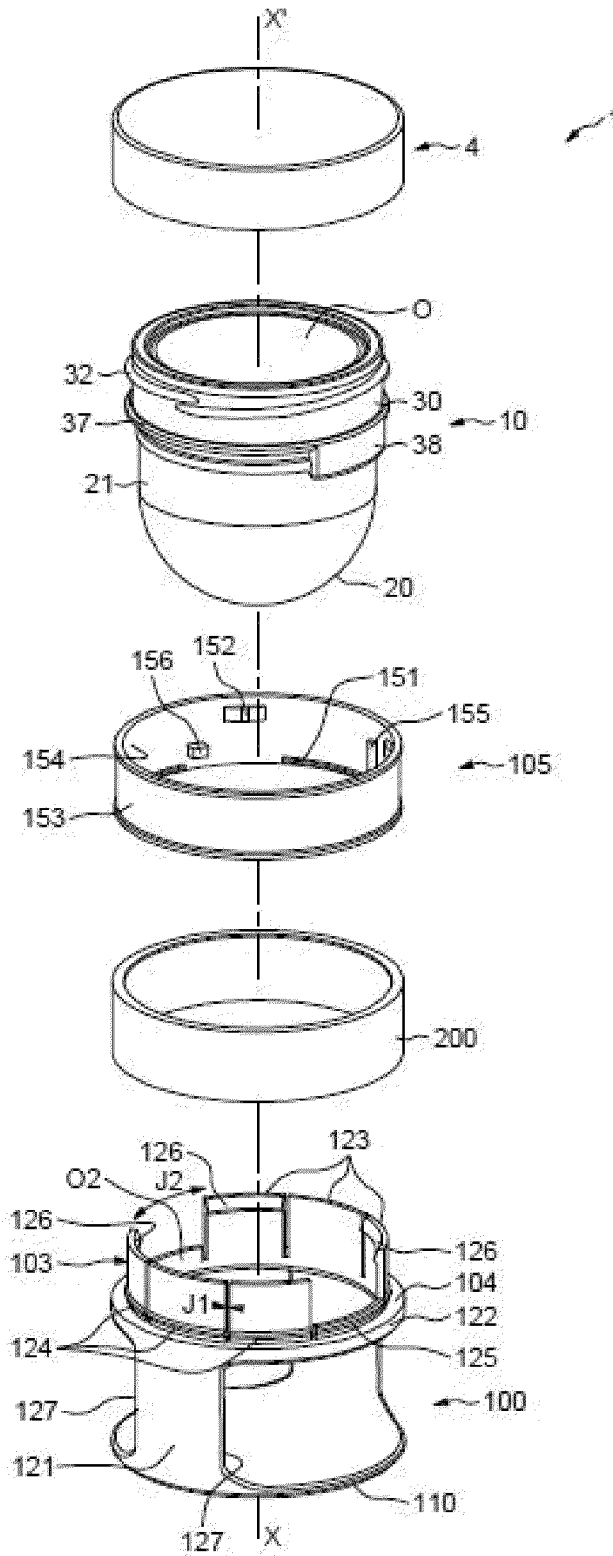

[Fig. 17]

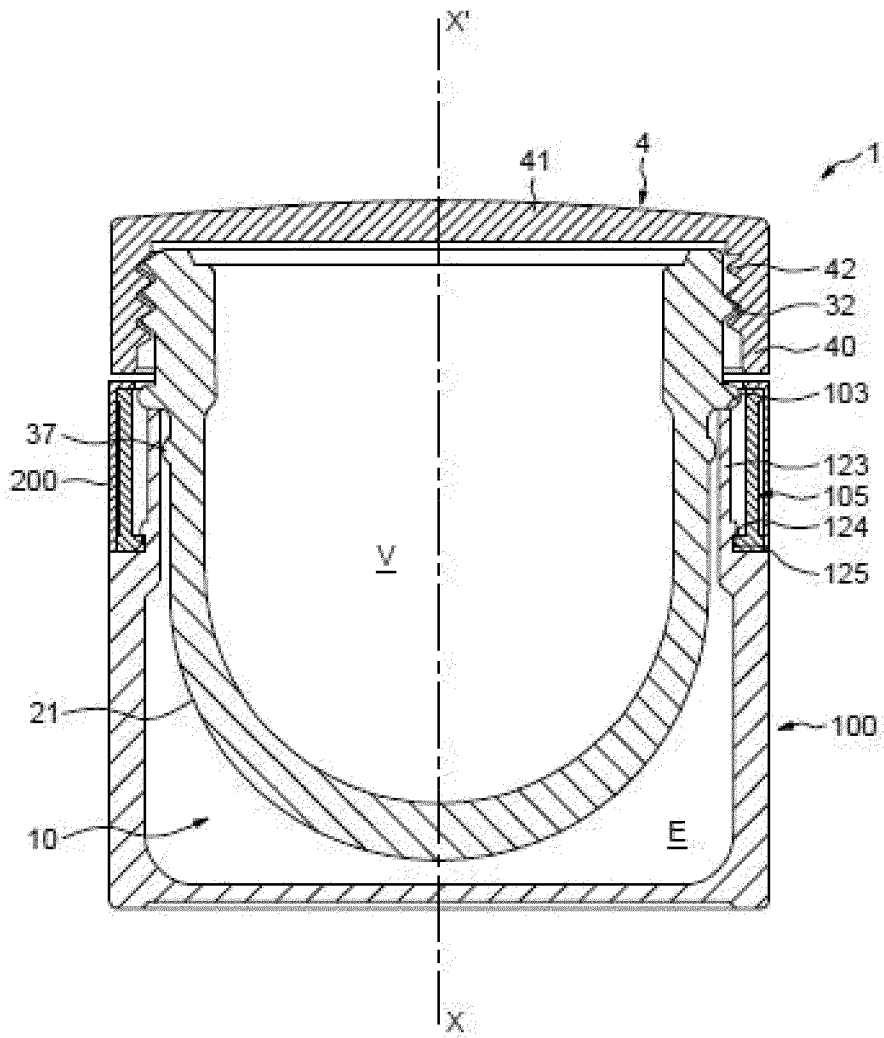

[Fig. 18A]

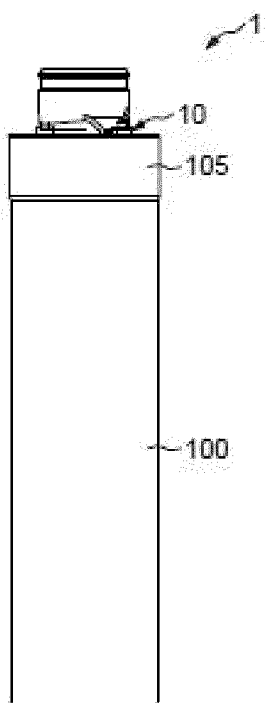

[Fig. 18B]

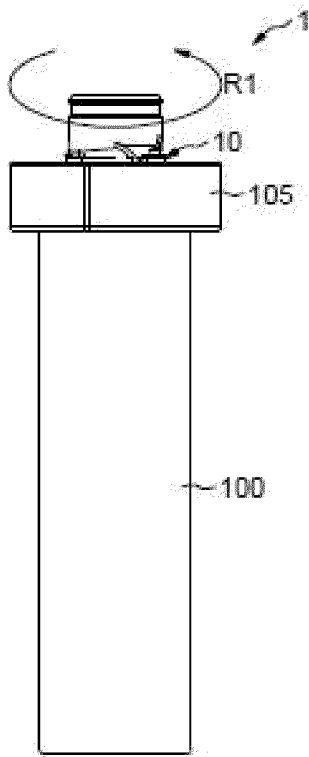

[Fig. 18C]

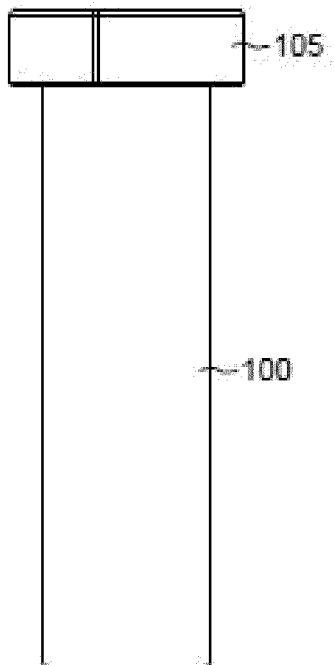
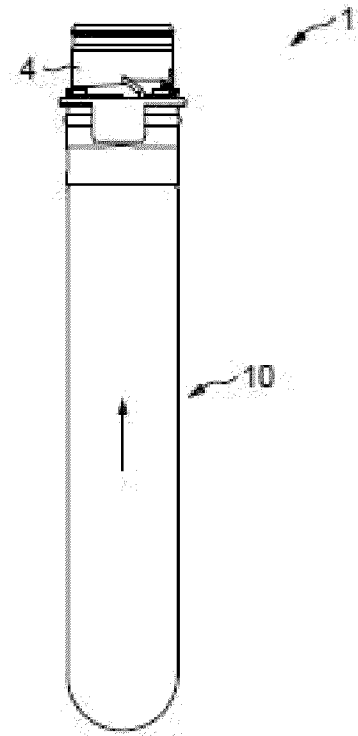

[Fig. 18D]

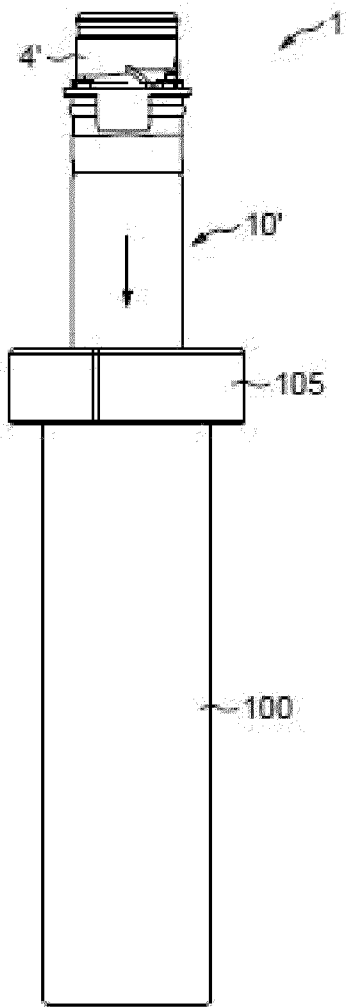

[Fig. 18E]

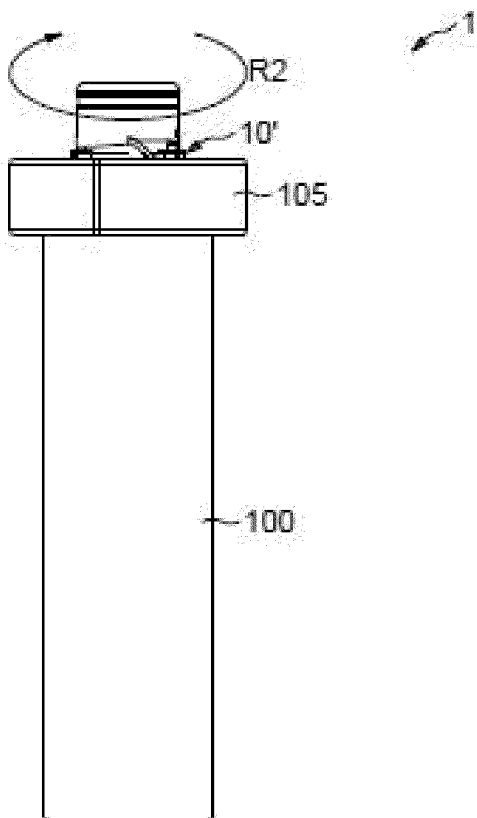

INTERNATIONAL SEARCH REPORT

International application No
PCT/EP2024/064877

A. CLASSIFICATION OF SUBJECT MATTER
 INV. A45D34/04 A45D40/00 A45D40/26
 ADD.

According to International Patent Classification (IPC) or to both national classification and IPC

B. FIELDS SEARCHED

Minimum documentation searched (classification system followed by classification symbols)
A45D

Documentation searched other than minimum documentation to the extent that such documents are included in the fields searched

Electronic data base consulted during the international search (name of data base and, where practicable, search terms used)

EPO- Internal

C. DOCUMENTS CONSIDERED TO BE RELEVANT

| Category* | Citation of document, with indication, where appropriate, of the relevant passages | Relevant to claim No. |
|------------|---|---|
| X A | <p>US 2022/211161 A1 (DEL DIN ANTOINE [FR] ET AL) 7 July 2022 (2022-07-07) paragraphs [0051], [0055], [0123], [0130], [0163] - [0184]; figures</p> <p style="text-align: center;">-----</p> | <p>1, 2, 5, 6, 13, 27, 28 3, 4, 7-12, 14-26, 29, 30</p> |

Further documents are listed in the continuation of Box C.

See patent family annex.

* Special categories of cited documents :

"A" document defining the general state of the art which is not considered to be of particular relevance

"E" earlier application or patent but published on or after the international filing date

"L" document which may throw doubts on priority claim(s) or which is cited to establish the publication date of another citation or other special reason (as specified)

"O" document referring to an oral disclosure, use, exhibition or other means

"P" document published prior to the international filing date but later than the priority date claimed

"T" later document published after the international filing date or priority date and not in conflict with the application but cited to understand the principle or theory underlying the invention

"X" document of particular relevance; the claimed invention cannot be considered novel or cannot be considered to involve an inventive step when the document is taken alone

"Y" document of particular relevance; the claimed invention cannot be considered to involve an inventive step when the document is combined with one or more other such documents, such combination being obvious to a person skilled in the art

"&" document member of the same patent family

Date of the actual completion of the international search

26 July 2024

Date of mailing of the international search report

26/08/2024

Name and mailing address of the ISA/
 European Patent Office, P.B. 5818 Patentlaan 2
 NL - 2280 HV Rijswijk
 Tel. (+31-70) 340-2040,
 Fax: (+31-70) 340-3016

Authorized officer

Dinescu, Daniela

INTERNATIONAL SEARCH REPORT

Information on patent family members

International application No

PCT/EP2024/064877

| Patent document cited in search report | Publication date | Patent family member(s) | Publication date |
|---|---------------------|----------------------------|---------------------|
| US 2022211161 A1 | 07-07-2022 | CN 114630598 A | 14-06-2022 |
| | | FR 3101066 A1 | 26-03-2021 |
| | | US 2022211161 A1 | 07-07-2022 |
| | | WO 2021058518 A1 | 01-04-2021 |
| ----- | | | |