



Europäisches Patentamt
European Patent Office
Office européen des brevets



(11) **EP 0 975 853 B1**

(12) **EUROPEAN PATENT SPECIFICATION**

(45) Date of publication and mention
of the grant of the patent:
23.02.2005 Bulletin 2005/08

(51) Int Cl.7: **E21B 31/00**, E21B 19/08,
E21B 19/22, E21B 28/00

(21) Application number: **99908080.7**

(86) International application number:
PCT/US1999/001875

(22) Date of filing: **16.02.1999**

(87) International publication number:
WO 1999/041487 (19.08.1999 Gazette 1999/33)

(54) **DOWNHOLE COILED TUBING RECOVERY APPARATUS**

VORRICHTUNG FÜR DAS ZURÜCKHOLEN VON EINEM IM BOHRLOCH GEWICKELTEN
ROHRSTRANG

APPAREIL DE RECUPERATION, D'UN FOND DE TROU, D'UN TUBE ENROULE

(84) Designated Contracting States:
DE DK GB NL

(72) Inventor: **BERNAT, Henry, A.**
Shreveport, LA 71106 (US)

(30) Priority: **17.02.1998 US 74951**
22.06.1998 US 90138 P

(74) Representative: **Driver, Virginia Rozanne et al**
Page White & Farrer
54 Doughty Street
London WC1N 2LS (GB)

(43) Date of publication of application:
02.02.2000 Bulletin 2000/05

(73) Proprietor: **Henry A. Bernat**
Shreveport, LA 71106 (US)

(56) References cited:
EP-A- 0 395 167 **US-A- 3 168 140**
US-A- 3 339 646 **US-A- 4 673 037**
US-A- 5 040 598 **US-A- 5 040 926**
US-A- 5 180 014 **US-A- 5 184 682**

EP 0 975 853 B1

Note: Within nine months from the publication of the mention of the grant of the European patent, any person may give notice to the European Patent Office of opposition to the European patent granted. Notice of opposition shall be filed in a written reasoned statement. It shall not be deemed to have been filed until the opposition fee has been paid. (Art. 99(1) European Patent Convention).

Description

Background of the Invention

Cross-Reference To Related Applications

[0001] This application claims the benefit of the following copending U.S. Provisional Applications: Serial No. 60/074,951, filed February 17, 1998 and 60/090,138, filed June 22, 1998.

Field of the Invention

[0002] This invention relates to the freeing of stuck or jammed tubulars or other objects downhole and more particularly, to a downhole coiled tubing recovery apparatus and method designed to utilize a resonant frequency oscillator in combination with a specially designed coiled tubing bail for directing coiled tubing directly from a tubing reel through an injector head and to and from the well responsive to raising and lowering of the oscillator and the tubing bail. Freeing of the tubulars or objects is accomplished by typically resonance vibration of the bail and coiled tubing by operation of the oscillator.

[0003] Oil field tubulars such as well liners, casing, tubing and drill pipe stuck in a well bore due to various downhole conditions have been one of the principal sources of problems for oil operators and have expanded the business activity of fishing service companies in this century. During this period of time, many new and innovative tools and procedures have been developed to improve the success and efficiency of fishing operations. Apparatus such as electric line free point tools, string shot assisted backoff, downhole jarring tools, hydraulic-actuated tools of various types and various other tools and equipment have been developed for the purpose of freeing stuck or jammed tubulars downhole in a well. Although use of this equipment has become more efficient with time, the escalation in cost of drilling and workover operations has resulted in a proliferation of stuck pipe, liners, casing and the like downhole, frequently leading to well abandonment as the most expedient resolution of the problem.

[0004] The use of vibration and resonant vibration in particular, as a means of freeing stuck tubulars from a well bore has the potential to be immediately effective and thus greatly and drastically reduce the cost involved in tubular recovery operations. Resonance occurs in vibration when the frequency of the excitation force is equal to the natural frequency of the system. When this happens, the amplitude (or stroke) of vibration will increase without bound and is governed only by the degree of damping present in the system.

[0005] A resonant vibrating system will store a significant quantity of energy, much like a flywheel. The ratio of the energy stored to the energy dissipated per cycle is referred to as the systems "Q". A high energy level

allows the system to transfer energy to a given load at an increased rate, much like an increase in voltage will allow a flashlight to burn brighter with a given bulb. Only resonant systems will achieve this energy buildup and exhibit the corresponding efficient energy transmission characteristics which assure large energy delivery and corresponding force application to a stuck region of pipe.

[0006] At resonant conditions, a string of pipe will transmit power over its length to a load at the opposite end with the only loss being that necessary to overcome resistance in the form of damping or friction. In effect, power is transmitted in the same manner as the drilling process transmits rotary power to a bit, the difference being that the motion is axial translation instead of rotation. The load accepts the transmitted power as a large force acting through a small distance. Resonant vibration of pipe can deliver substantially higher sustained energy levels to a stuck tubular than any conventional method, including jarring. This achievement is due to the elimination of the need to accelerate or physically move the mass of the pipe string. Under resonant conditions, the power is applied to a vibrating string of pipe in phase with the natural movement of the pipe string.

[0007] When an elastic body is subjected to axial strain, as in the stretching of a length of pipe, the diameter of the body will contract. Similarly, when the length of pipe is compressed, its diameter will expand. Since a length of pipe undergoing vibration experiences alternate tensile and compressive forces as waves along the longitudinal axis (and therefore longitudinal strains), the pipe diameter will expand and contract in unison with the applied tensile and compressive waves. This means that for alternate moments during a vibration cycle the pipe may actually be physically free of its bond.

[0008] The term "fluidization" is used to describe the action of granular particles when excited by a vibrational source of proper frequency. Under this condition, granular material is transformed into a fluidic state that offers little resistance to movement of body through the media. In effect, it takes some of the characteristics and properties of a liquid. Accordingly, skin friction, that force that confines a stuck tubular, is reduced to a fraction of its normal value due to the effect of vibration because of alternate tensile and compressive forces applied to a pipe and to the fluidization of granular particles packed around the pipe.

[0009] Another factor in reducing stuck tubulars downhole is acceleration, wherein a suitable vibrational stroke may need to be only about an inch in order to produce good acceleration for friction reduction and fluidization. Accordingly, the vibrational energy received at the stuck area works to effect the release of a stuck member through the application of large percussive forces, fluidization of granular material, dilation and contraction of the pipe body and a reduction of well bore friction or hole drag.

Description of the Prior Art

[0010] Resonant vibration systems for use in oilfield tubular extraction applications consist of three basic components: a mechanical oscillator with a suspension device for isolating the rig or Support structure, a work string for transmitting vibrational energy, and the stuck tubular or fish to be recovered. The oscillator generates an axial sinusoidal force that can be tuned to a given frequency within a specified operating range. The force generated by the oscillator acts on the work string to create axial vibration of the string. When tuned to a resonant frequency of the system, energy developed at the oscillator is efficiently transmitted to the stuck member with the only losses being those attributed to frictional resistance. The effect of the system reactance is completely eliminated because mass inductance is equal to spring capacitance at the resonant frequency. The total resonant system must be designed so that the components act in concert with one another, thus providing an efficient and effective extraction system.

[0011] In conventional coiled tubing operations one of the actions that is detrimental to the life of the coiled tubing is that of continually working the pipe to and from the tubing reel, back and forth over the well entry gooseneck. This action induces bending yield stress into the tubing, which results in accumulated fatigue damage and can eventually lead to fatigue failure of the tubing wall. Modern instrumentation allows monitoring of the tubing bending action and the coil service company will monitor and record that action so that the coil is not used beyond its useful life.

[0012] The principal of resonant axial vibration of pipe can be applied to coiled tubing without using the gooseneck equipment. Additionally, it has been found that the coiled tubing does not necessarily need to be cut when used with the downhole coiled tubing recovery apparatus of this invention, thus saving the cost of a reel of tubing, as well as maintaining and enabling good well control, along with the facility for circulating fluids into and from the well.

[0013] Various pipe recovery techniques are well known in the art. An early pipe recovery device is detailed in U.S. Patent No. 2,340,959, dated February 8, 1944, to P.E. Harth. The Harth device is characterized by a suitable electrical or mechanical vibrator which is inserted into the pipe to be removed, such that the vibrator may be activated to loosen the pipe downhole in the well and enable removal of the pipe. A well pipe vibrating apparatus is detailed in U.S. Patent No. 2,641,927, dated June 16, 1953, to D. B. Grabel, et al. The device includes a vibrating element and a motor-powered drive which is inserted in a well pipe to be loosened and removed, to effect vibration of the pipe and subsequent extraction of the pipe from the well. U.S. Patent No. 2,730,176, dated January 10, 1956, to W. K. J. Herbold, details a means for loosening pipes in underground borings. The apparatus includes a device ar-

ranged within a paramagnetic cylindrical body including a drill, a rod rotatably mounted within the body and a disc member secured to one end of the drill rod, the disc member having a mass which is substantially equally distributed around the axis of the drill rod to define a surface of revolution. A motor is provided for rotating the drill rod and a magnetic apparatus for forcing the disc member into physical contact with the inner walls of the body and into rolling contact with the inner surface of the pipe upon rotation of the drill rod, to loosen the pipe downhole. U.S. Patent No. 2,972,380, dated February 21, 1961, to A. G. Bodine, Jr., details an acoustic method and apparatus for moving objects held tightly within a surrounding medium. The device includes a vibratory output member of an acoustic wave generator attached to an acoustically-free portion of the stuck tubular. The method includes operating the generator at a resonant frequency to establish a velocity node adjacent to the stuck point and a velocity antinode at the coupling point adjacent to the generator, to loosen the stuck member from the well. U.S. Patent No. 3,189,106, dated June 15, 1965, to A. G. Bodine, Jr., details a sonic pile driver which utilizes a mechanical Oscillator and a pile coupling device for coupling the oscillator body to a pile and applying vibrations of the pile to drive the pile into the ground. U.S. Patent No. 3,500,908, dated March 17, 1970, to U. S. Barler, details apparatus and method for freeing well pipe. The device includes a number of rotatable, power-driven eccentrics which are connected to an elongated member such as a drill pipe that is stuck in an oil well bore hole and to a resiliently-movable support suspended from the traveling block of an oil derrick. When the power-driven eccentrics are operated, the elongated member is subjected to vertically-directed forces that free it from the stuck position. U.S. Patent No. 4,429,743, dated February 7, 1984, to Albert G. Bodine, details a well servicing system employing sonic energy transmitted down the pipe string. The sonic energy is generated by an orbiting mass oscillator coupled to a central stem, to which the piston of a cylinder-piston assembly is connected. The cylinder is suspended from a suitable suspension means such as a derrick, with the pipe string being suspended from the piston in an in-line relationship. The fluid in the cylinder affords compliant loading for the piston, while the fluid provides sufficiently high pressure to handle the load of the pipe string and any pulling force thereon. The sonic energy is coupled to the pipe string in the longitudinal vibration mode, which tends to maintain this energy along the string. U.S. Patent No. 4,574,888 dated March 11, 1986, to Wayne E. Vogen, details a "Method and Apparatus For Removing Stuck Portions of A Drill String". The lower end of an elastic steel column is attached to the upper end of the stuck element and the upper end of the column extends above the top of the well and is attached to a reaction mass lying vertically above, through an accelerometer and vertically-mounted compression springs in parallel with a vertically-mounted servo-con-

trolled, hydraulic cylinder-piston assembly. vertical vibration is applied to the upper end of the column to remove the stuck element from the well. A "Device For Facilitating the Release of Stuck Drill Collars" is detailed in U.S. Patent No. 4,576,229, dated March 18, 1986, to Robert L. Brown. The device includes a first member mounted with the drill pipe disposed in a first position and a second member concentrically mounted with a drill collar or drill pipes in a second position below the first position. Rotation of the drill string from the surface causes a camming action and vibration in a specified operative position of the device, which helps to free stuck portions of the drill pipe. U.S. Patent No. 4,788,467, dated November 29, 1988, to E.D. Plambeck details a downhole oil well vibrating apparatus that uses a transducer assembly spring chamber piston and spring to effect vibration of downhole tubulars. U.S. Patent No. 5,234,056, dated August 10, 1993, to Albert G. Bodine, details a "Sonic Method and Apparatus For Freeing A Stuck Drill String". The device includes a mechanical oscillator employing unbalanced rotors coupled to the top end of a drill string stuck in a bore hole. Operation of the unbalanced rotors at a selected frequency provides resonant vibration of the drill string to effect a reflected wave at the stuck point, resulting in an increased cyclic force at this point.

[0014] The prior art is well established regarding the application of vibration to stuck downhole tubulars of the conventional type (threaded pipe). E.P. Patent 0 395 167 details an apparatus and a method of drilling using a coiled tubing. There is no suggestion, however, of any means or method for handling continuous pipe such as coiled tubing, in a vibrational or any other application. It is thus an object of this invention to provide an apparatus and method for working coiled tubing in a stuck pipe or other downhole stuck equipment situation, wherein the coil may be raised and lowered in the well bore by a support structure that includes a lifting and lowering apparatus. Such movement of the coil is accomplished with substantially no bending of the coil string.

[0015] Another object of this invention to provide a new and improved downhole coiled tubing recovery apparatus and method for releasing and recovering coiled tubing and other objects stuck or jammed downhole in a well.

[0016] Yet another object of this invention is to provide a new and improved downhole coiled tubing recovery apparatus and method which operates utilizing resonant vibration in combination with a specially designed coiled tubing bail to facilitate the release of stuck or jammed coiled tubing from a well.

[0017] Another object of the invention is to provide a new and improved coiled tubing recovery apparatus that may be applied to a continuous length of coiled tubing without cutting the tubing, and operated to vibrate the coiled tubing and remove the coiled tubing and other objects from a stuck or jammed position in the well.

[0018] A still further object of this invention is to pro-

vide a new and improved downhole coiled tubing recovery apparatus which is characterized by specially designed coiled tubing bail adapted to receive a length of coiled tubing from a reel and direct the coiled tubing through an injector head into and from the well, the coiled tubing bail being attached directly to the rig or to an oscillator suspended from the rig for selectively vibrating the coiled tubing and removing the coiled tubing from a stuck or jammed condition in the well.

[0019] Still another object of this invention is to provide a downhole coiled tubing recovery apparatus which utilizes an oscillator for attachment to a length of coiled tubing and applying a resonant vibration directly to the coiled tubing for removing the coiled tubing from a stuck or jammed condition in a well.

[0020] Another object of this invention is to provide a downhole coiled tubing recovery apparatus and method, which apparatus is characterized by an oscillator suspended from a rig or other support structure and a coiled tubing bail attached to the oscillator for receiving a length of coiled tubing extending from a coiled tubing reel and directing the coiled tubing through an injector head into the well, such that the oscillator can be operated to vibrate the coiled tubing, typically at a resonant frequency, and remove the coiled tubing from a stuck or jammed condition in the well.

[0021] Yet another object of the invention is to provide a coiled tubing recovery apparatus and method which is designed to vibrate jammed or stuck coiled tubing and reduce the friction of tubing insertion and extraction in a well.

Summary of the Invention

[0022] These and other objects of the invention are provided in new and improved coiled tubing recovery apparatus and method according to claims 1, 6, 10 and 11. In a preferred embodiment, a specially designed coiled tubing bail is suspended directly from a rig structure or from an oscillator that is further suspended from the travelling block or other supporting structural element of an oil derrick or rig, the coiled tubing is directed from a reel through a set of rod clamps in the coiled tubing bail and through an injector head, into the well bore. In the event of a stuck or jammed condition of the coiled tubing in the well bore, the coiled tubing bail can be lifted and/or the oscillator can be lifted and operated to apply resonant vibration through the coiled tubing bail and the coiled tubing to loosen the coiled tubing in the well hole.

Brief Description of the Drawings

[0023] The invention will be better understood by reference to the accompanying drawings, wherein:

FIGURE 1 is a perspective view of a typical coiled tubing oscillator and a bail element (rod clamps removed for brevity) of the downhole coiled tubing re-

covery apparatus of this invention, with a length of coiled tubing extending through the bail and into an injector head;

FIGURE 2 is a front view of the coiled tubing oscillator and bail illustrated in FIGURE 1;

FIGURE 3 is a front view of an alternative embodiment of the invention wherein a length of the coiled tubing is attached directly to the oscillator;

FIGURE 4 is a front view of a preferred embodiment of the coiled tubing bail element of the downhole coiled tubing recovery apparatus of this invention; FIGURE 5 is a side view of the coiled tubing bail illustrated in FIGURE 4;

FIGURE 6 is a perspective view of the coiled tubing bail illustrated in FIGURES 4 and 5; and

FIGURE 7 is a front view of a typical union for connecting the length of coiled tubing to the oscillator in the embodiment of the invention illustrated in FIGURE 3.

Description of the Preferred Embodiments

[0024] Referring initially to FIGURES 1, 2 and 4-6 of the drawings, in a first preferred embodiment the coiled tubing recovery apparatus of this invention is generally illustrated by reference numeral 1. The coiled tubing recovery apparatus 1 includes a coiled tubing bail 2, more particularly illustrated in FIGURES 4-6, including a union connector 3 at the top end thereof, having a connector opening 3a, fitted with internal connector threads 3b (FIGURE 6). A connector plate 4 joins a pair of vertically-oriented, parallel bail legs 5 at the union connector 3 and the bottom ends of the bail legs 5 are connected by means of a pair of parallel tubing plates 6, joined by plate bolts 7, secured by nuts 8, as further illustrated in FIGURES 4-6. In a most preferred embodiment, two sets of the plate bolts 7 extend through the respective bail legs 5, while another set of the plate bolts 7 extend in spaced-apart relationship with respect to each other near the center of the tubing plate 6, for accommodating the downhole segment 29 of a length of coiled tubing 28, as illustrated in FIGURES 1 and 2.

[0025] As further illustrated in FIGURES 1 and 2, the coiled tubing 28 is typically conventionally wound on a tubing reel 32, and is directed through the parallel bail legs 5, between the tubing plates 6 of the coiled tubing bail 2 and through one or more clamps, such as the conventional rod clamps 10, having clamp jaws 11, connected by jaw bolts 12, as further illustrated in FIGURE 2. Accordingly, it will be appreciated from a consideration of FIGURES 1 and 2 that the coiled tubing 28 is characterized by a tubing reel segment 30, which is wound on the tubing reel 32 and extends from the tubing reel 32 to the coiled tubing bail 2, where a downhole segment 29 of the coiled tubing 28 projects through the rod clamps 10 and between the respective tubing plates 6, through an injector head 14 that usually serves to insert the coiled tubing 28 into a well bore (not illustrated) and

remove the coiled tubing 28 from the well bore as desired, according to the knowledge of those skilled in the art.

[0026] Referring again to FIGURES 1 and 2 of the drawings, the coiled tubing bail 2 is typically suspended from a conventional oscillator 22 at a union 16, detailed in FIGURE 7. The union 16 is typically characterized by a top coupler 17, having exterior top coupler threads 18 that threadably engage the internal coupler threads (not illustrated) shaped in the oscillator 22. The bottom coupler threads 20 of the bottom coupler 19 engage the connector opening threads 3b in the connector opening 3a of the union connector 3, as further illustrated in FIGURE 6. However, it will be appreciated by those skilled in the art that the coiled tubing bail 2 can be suspended from the oscillator 22 in other ways, such as by direct threaded attachment, slips and the like, as desired. The conventional oscillator 22 is typically characterized by an eccentric housing 23, which houses at least one pair of eccentrics (not illustrated) that are connected to the motor shafts 25 (FIGURE 2) of a pair of eccentric drive motors 24. A spring housing 26 is positioned above the eccentric housing 23 for enclosing several springs (not illustrated) and isolating the vibration from the eccentrics located in the eccentric housing 23. The oscillator 22 is typically suspended from the travelling block or other element of an oil derrick or rig, (not illustrated), positioned over the well. Alternatively, the coiled tubing bail 2 can be attached directly to the travelling block or other component of the oil derrick or rig by means of threaded couplings, slips, or the like.

[0027] In operation according to the method of this invention, the downhole segment 29 of the coiled tubing 28 may be extended through the respective loosened clamp jaws 11 of the rod clamps 10, and between the parallel tubing plates 6, into the injector head 14, as illustrated in FIGURE 1. When it is desired to extend or insert the downhole segment 29 of the coiled tubing 28 into the well, the injector head 14 is released from the downhole segment 29 and the coiled tubing bail 2 is raised and lowered, as necessary. Alternatively, the injector head 14 may be operated in conventional fashion to feed the coiled tubing 28 into the well. As the downhole segment 29 is fed into the well through the injector head 14, the tubing reel segment 30 of the coiled tubing 28 unwinds from the rotating tubing reel 32. It will be appreciated that during this procedure, the clamp jaws 11 of the rod clamps 10 are sufficiently slack by manipulation of the jaw bolts 12 to facilitate easy sliding movement of the coiled tubing 28 through the respective rod clamps 10 and between the tubing plates 6 and the spaced-apart inside ones of the plate bolts 7. Normal bottom hole operations utilizing the coiled tubing 28 can be effected upon completion of the insertion of the coiled tubing 28 into the well. However, under circumstances where the coiled tubing 28 gets stuck or jammed in the well due to well bore cave-in or other adverse downhole phenomena, retrieval of the coiled tubing 28 from the

well bore can be achieved by operating the oscillator 22 to apply a vibration, typically at resonant frequency, to the coiled tubing bail 2 and the coiled tubing 28, attached to the coiled tubing bail 2, and release the coiled tubing 28 from the stuck or jammed condition in the well. In the course of applying a resonant frequency to the coiled tubing 28, the oscillator 22 generates an axial sinusoidal force that can be tuned to a specified frequency within the operating range of the oscillator 22. The force generated by, the oscillator 22 acts on the coiled tubing 28 to create axial vibration of the downhole segment 29 of the coiled tubing 28. When tuned to a resonant frequency of the system, energy developed at the oscillator 22 is efficiently transmitted to the stuck downhole segment 29 of the coiled tubing 28, with the only losses being those attributed to frictional resistance. The effect of the coiled tubing 28 reactance is completely eliminated, because mass induction is equal to spring capacitance at the resonant frequency. Other aspects of the oscillator 22 operation is the fluidization of the granular particles downhole in the event that the cause of the stuck downhole segment 29 of the coiled tubing 28 results from a cave-in or silting of the hole or jamming of downhole objects to create a mechanical wedging action against the downhole segment 29 of the coiled tubing 28. When excited by a vibration from the oscillator 22, the granular particles are transformed into a fluidic state that offers little resistance to movement of the coiled tubing 28 upwardly or downwardly. In effect, the granular media takes on the characteristics and properties of a liquid and facilitates extraction of the downhole segment 29 of the coiled tubing 28 by elevating and/or lowering the coiled tubing 28 as described above.

[0028] Referring now to FIGURE 3 of the drawings, in another preferred embodiment of the invention the tubing reel segment 30 of the coiled tubing 28 may be cut and connected directly to the union 16 of the oscillator 22 to eliminate the coiled tubing bail 2. In this operation, the downhole segment 29 of the coiled tubing 28 may first be extended directly through the injector head 14 and conventionally, lowered into the well directly from the tubing reel 32 through the injector head 14, for commencement of downhole operations utilizing the coiled tubing 28. Under circumstances where the downhole segment 29 of the coiled tubing 28 becomes stuck or jammed in the well, the coiled tubing 28 is cut at a point above the injector head 14 and the tubing reel segment 30 attached to the union 16 by techniques known to those skilled in the art, and the oscillator 22 is then operated as described above, to free the coiled tubing 28 downhole. When the coiled tubing 28 is free, the upper end, or tubing reel segment 30 of the coiled tubing 28 is disconnected from the union 16 and the injector head 14 is reverse-operated to remove the coiled tubing 28 from the well, as described above. Alternatively, the coiled tubing bail 2 can be attached directly to the travelling block or other rig component as described above and the travelling block lifted to free the coiled tubing 28

from the well.

[0029] It will be appreciated by those skilled in the art that one of the advantages of the coiled tubing recovery apparatus and method of this invention is the facility for manipulating the coiled tubing 28 directly from the tubing reel 32 without the necessity of cutting the coiled tubing 28 in the embodiments illustrated in FIGURES 1, 2 and 4-6. Another advantage is the elimination of the conventional "gooseneck" equipment, which tends to degrade the coiled tubing 28 through multiple bends over the gooseneck as the coiled tubing 28 is inserted into and removed from the well by operation of the injector head 14.

[0030] While the preferred embodiments of the invention have been described above, it will be recognized and understood that various modifications may be made in the invention and the appended claims are intended to cover all such modifications which may fall within the spirit and scope of the invention.

[0031] Having described my invention with the particularity set forth above, what is claimed is:

Claims

1. A coiled tubing recovery apparatus for freeing a continuous coiled tubing (28) in a well **characterized by** a vibrator (22) suspended above the well, a coupler (16) carried by said vibrator and a coiled tubing bail (2) carried by said coupler for receiving and guiding the coiled tubing into the well and vibrating the coiled tubing responsive to operation of said vibrator.
2. The coiled tubing recovery apparatus of claim 1 further comprising means for applying an upward or downward force to the coiled tubing bail for removing the coiled tubing from the well.
3. The coiled tubing recovery apparatus of claim 1 further comprising at least one clamp means (10) carried by said coiled tubing bail for receiving and selectively clamping the coiled tubing.
4. The coiled tubing recovery apparatus of claim 1 further comprising means for raising the vibrating apparatus for exerting tension on the coiled tubing or lowering the vibrating apparatus for applying a compressive load on the coiled tubing.
5. The coiled tubing recovery apparatus of any preceding claim wherein said vibrator is capable of vibrating the coiled tubing at a resonant frequency.
6. A method for freeing a continuous coiled tubing (28) in a well **characterised by** the steps of suspending a vibrating apparatus (22) over the well, attaching the coiled tubing to the vibrating apparatus, and op-

erating the vibrating apparatus to vibrate the coiled tubing in the well.

7. The method according to claim 6 further comprising suspending a coiled tubing bail (2) from the vibrating apparatus, and clamping the coiled tubing to the coiled tubing bail. 5
8. The method according to claim 6 or 7 further comprising raising the vibrating apparatus for exerting tension on the coiled tubing or lowering the vibrating apparatus for applying a compressive load on the coiled tubing. 10
9. The method according to any of claim 6 to 8 further comprising operating the vibrating apparatus to vibrate the coiled tubing at a resonant frequency. 15
10. A method according to claim 6, comprising cutting the coiled tubing, and attaching the portion of the coiled tubing extending into the well to the vibrating apparatus and operating the vibrating apparatus to vibrate said portion of the coiled tubing in the well. 20
11. A coiled tubing recovery apparatus for freeing a continuous coiled tubing in a well **characterised by** a coiled tubing bail suspended above the well for receiving and guiding the coiled tubing into the well. 25
12. A method for freeing a continuous coiled tubing in a well **characterised by** the steps of suspending a coiled tubing bail over the well, selectively clamping the coiled tubing to the coiled tubing bail, and raising the coiled tubing bail for exerting tension on the coiled tubing or lowering the coiled tubing bail for applying a compressive load on the coiled tubing. 30 35

Patentansprüche

1. Vorrichtung zum Zurückholen eines gewickelten Rohrstranges zum Befreien eines kontinuierlichen gewickelten Rohrstranges (28) in einem Bohrloch, **gekennzeichnet durch** einen Vibrator (22), der oberhalb des Bohrloches aufgehängt ist, einen Koppler (16), der **durch** den Vibrator getragen wird, und einem Halter (2) für den gewickelten Rohrstrang, der **durch** den Koppler zur Aufnahme und Führung des gewickelten Rohrstranges in das Bohrloch und zum Vibrieren des gewickelten Rohrstranges in Reaktion auf den Betrieb des Vibrators getragen wird. 45 50
2. Vorrichtung zum Zurückholen eines gewickelten Rohrstranges nach Anspruch 1, außerdem mit Mitteln zum Aufbringen einer Aufwärts- oder Abwärtskraft auf den Halter für den gewickelten Rohrstrang zum Entfernen des gewickelten Rohrstranges aus

dem Bohrloch.

3. Vorrichtung zum Zurückholen eines gewickelten Rohrstranges gemäß Anspruch 1, außerdem mit wenigstens einem Klemmmittel (10), das durch den Halter für den gewickelten Rohrstrang getragen wird, um den gewickelten Rohrstrang aufzunehmen und wahlweise zu klemmen.
4. Vorrichtung zum Zurückholen des gewickelten Rohrstranges nach Anspruch 1, außerdem mit Mitteln zum Anheben der Vibrationsvorrichtung zum Ausüben von Spannung auf den gewickelten Rohrstrang oder zum Absenken der Vibrationsvorrichtung zum Aufbringen einer kompressiven Last auf den gewickelten Rohrstrang.
5. Vorrichtung zum Zurückholen eines gewickelten Rohrstranges nach einem der vorhergehenden Ansprüche, wobei der Vibrator in der Lage ist, den gewickelten Rohrstrang mit einer Resonanzfrequenz zum Vibrieren zu bringen.
6. Verfahren zum Befreien eines kontinuierlichen gewickelten Rohrstranges (28) in einem Bohrloch, **gekennzeichnet durch** die Schritte des Aufhängens einer Vibrationsvorrichtung (22) oberhalb des Bohrloches, Befestigen des gewickelten Rohrstranges an der Vibrationsvorrichtung und Betreiben der Vibrationsvorrichtung, um den gewickelten Rohrstrang in dem Bohrloch zum Vibrieren zu bringen.
7. Verfahren nach Anspruch 6, außerdem umfassend das Aufhängen eines Halters (2) für den gewickelten Rohrstrang an der Vibrationsvorrichtung und Festklemmen des gewickelten Rohrstranges an dem Halter für den gewickelten Rohrstrang.
8. Verfahren nach Anspruch 6 oder 7, außerdem umfassend das Anheben der Vibrationsvorrichtung zum Ausüben von Spannung auf den gewickelten Rohrstrang oder das Absenken der Vibrationsvorrichtung zum Aufbringen einer kompressiven Last auf den gewickelten Rohrstrang.
9. Verfahren nach einem der Ansprüche 6 bis 8, außerdem umfassend das Betreiben der Vibrationsvorrichtung um den gewickelten Rohrstrang bei einer Resonanzfrequenz zum Vibrieren zu bringen.
10. Verfahren nach Anspruch 6, umfassend das Schneiden des gewickelten Rohrstranges und das Befestigen des Abschnittes des gewickelten Rohrstranges, der sich in das Bohrloch erstreckt, an der Vibrationsvorrichtung, und das Betreiben der Vibrationsvorrichtung, um den Abschnitt des gewickelten Rohrstranges in dem Bohrloch zum Vibrieren

zu bringen.

11. Vorrichtung zum Zurückholen eines gewickelten Rohrstranges zum Befreien eines kontinuierlichen gewickelten Rohrstranges in einem Bohrloch, **gekennzeichnet durch** einen Halter für den gewickelten Rohrstrang, der oberhalb des Bohrlochs aufgehängt ist, um den gewickelten Rohrstrang aufzunehmen und in das Bohrloch zu führen. 5
12. Verfahren zum Befreien eines kontinuierlichen gewickelten Rohrstranges in einem Bohrloch, **gekennzeichnet durch** die Schritte des Aufhängens eines Halters für den gewickelten Rohrstrang oberhalb des Bohrloches, wahlweises Festklemmen des gewickelten Rohrstranges an dem Halter für den gewickelten Rohrstrang und Anheben des Halters für den gewickelten Rohrstrang zum Ausüben von Spannung auf den gewickelten Rohrstrang oder zum Absenken des Halters für den gewickelten Rohrstrang zum Aufbringen einer kompressiven Last auf den gewickelten Rohrstrang. 10 15 20

Revendications

1. Dispositif de récupération d'un tube enroulé pour libérer un tube enroulé continu (28) dans un puit, **caractérisé par** un vibreur (22) suspendu au-dessus du puit, un coupleur (16) porté par le vibreur et une cage de tube enroulé (2) portée par le coupleur pour recevoir et guider le tube enroulé dans le puit et faire vibrer le tube enroulé en réponse au fonctionnement du vibreur. 30
2. Dispositif de récupération d'un tube enroulé selon la revendication 1, comprenant en outre des moyens pour appliquer une force vers le haut ou vers le bas à la cage de tube enroulé pour enlever le tube enroulé du puit. 35
3. Dispositif de récupération d'un tube enroulé selon la revendication 1, comprenant en outre au moins un moyen de pince (10) porté par la cage de tube enroulé pour recevoir et bloquer sélectivement le tube enroulé. 45
4. Dispositif de récupération d'un tube enroulé selon la revendication 1, comprenant en outre des moyens pour soulever l'appareil vibrant pour exercer une tension sur le tube enroulé ou abaisser l'appareil vibrant pour appliquer une force de compression sur le tube enroulé. 50
5. Dispositif de récupération d'un tube enroulé selon l'une quelconque des revendications précédentes, dans lequel le vibreur est susceptible de faire vibrer le tube enroulé à une fréquence de résonance. 55

6. Procédé pour libérer un tube enroulé continu (28) dans un puit, **caractérisé par** les étapes consistant à suspendre un appareil vibrant (22) au dessus du puit, à fixer le tube enroulé à l'appareil vibrant, et à faire fonctionner l'appareil vibrant pour faire vibrer le tube enroulé dans le puit. 5
7. Procédé selon la revendication 6, comprenant en outre l'étape consistant à suspendre une cage de tube enroulé (2) à partir de l'appareil vibrant et à bloquer le tube enroulé sur la cage de tube enroulé. 10
8. Procédé selon la revendication 6 ou 7, comprenant l'étape consistant à soulever l'appareil vibrant pour exercer une tension sur le tube enroulé ou à abaisser l'appareil vibrant pour appliquer une force de compression au tube enroulé. 15
9. Procédé selon l'une quelconque des revendications 6 à 8, comprenant en outre l'étape consistant à faire fonctionner l'appareil vibrant pour faire vibrer le tube enroulé à une fréquence de résonance. 20
10. Procédé selon la revendication 6, comprenant l'étape consistant à couper le tube enroulé et à fixer la partie de tube enroulé s'étendant dans le puit à l'appareil vibrant et à faire fonctionner l'appareil vibrant pour faire vibrer la partie du tube enroulé dans le puit. 25
11. Dispositif de récupération d'un tube enroulé pour libérer un tube enroulé continu dans un puit, **caractérisé par** une cage de tube enroulé suspendue au dessus du puit pour recevoir et guider le tube enroulé dans le puit. 35
12. Procédé pour libérer un tube enroulé continu dans un puit, **caractérisé par** les étapes consistant à suspendre une cage de tube enroulé au dessus du puit, à verrouiller sélectivement le tube enroulé à la cage de tube enroulé, et à soulever la cage de tube enroulé pour exercer une tension sur le tube enroulé ou à abaisser la cage de tube enroulé pour appliquer une force de compression au tube enroulé. 40 45

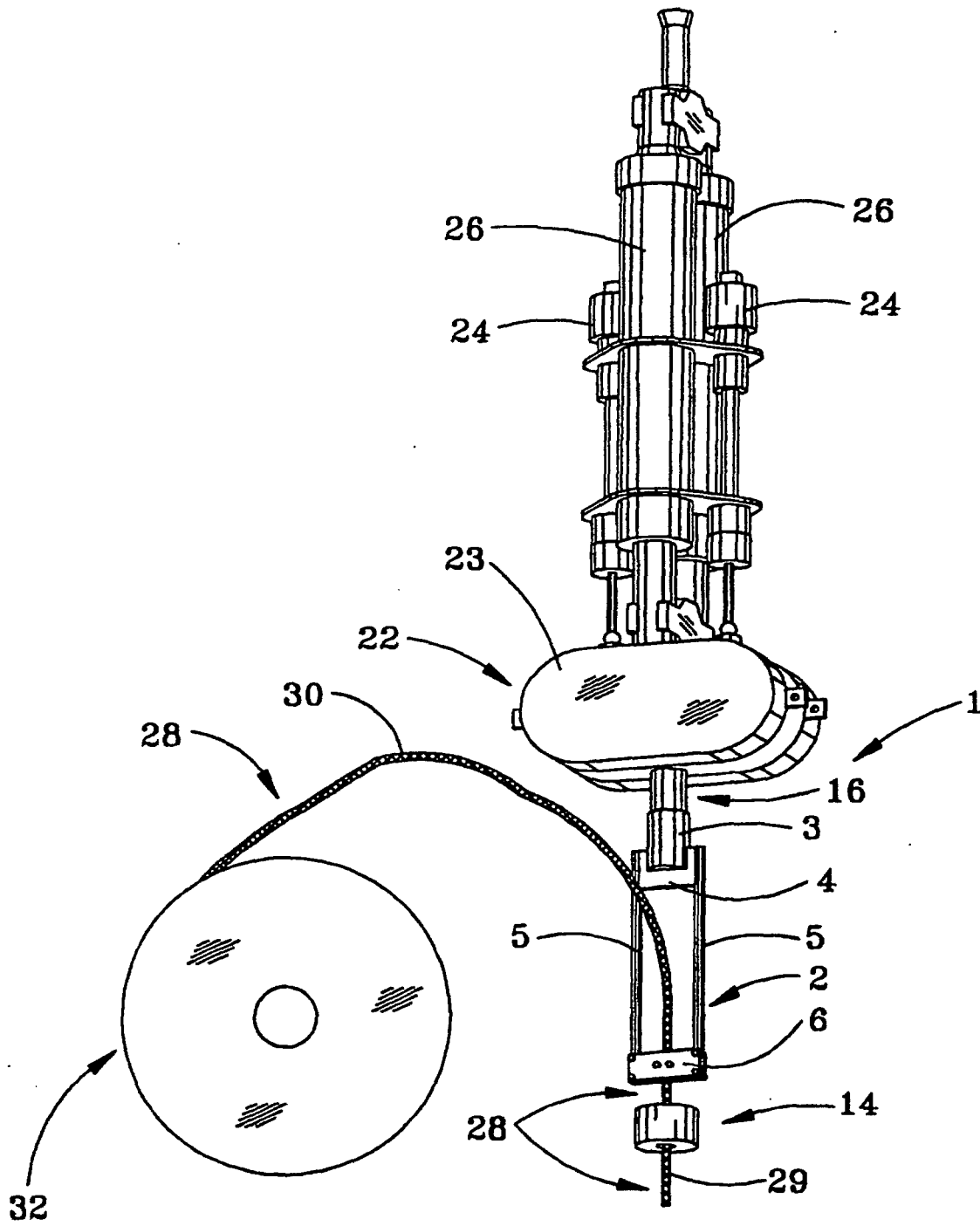

FIG. 1

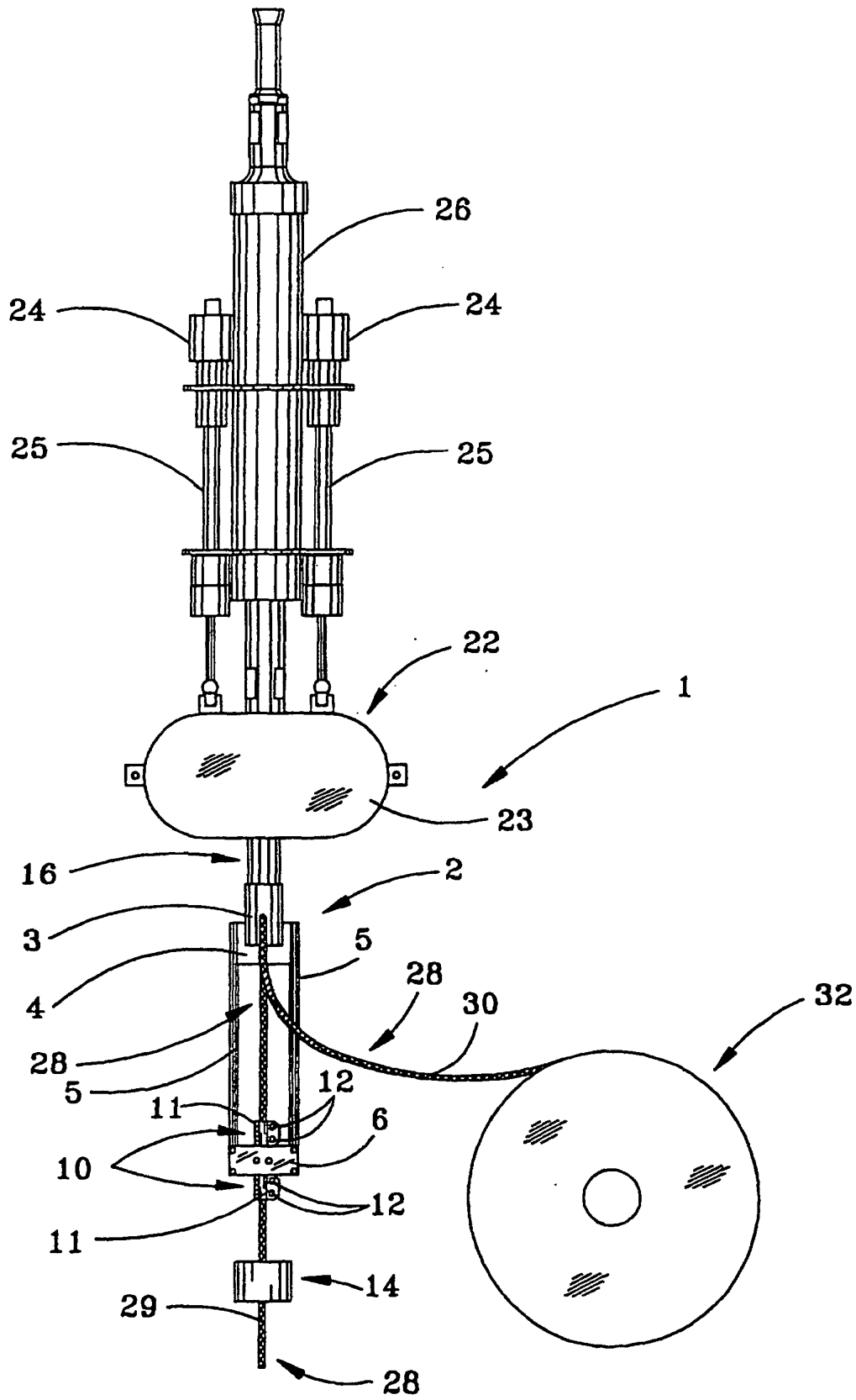

FIG.2

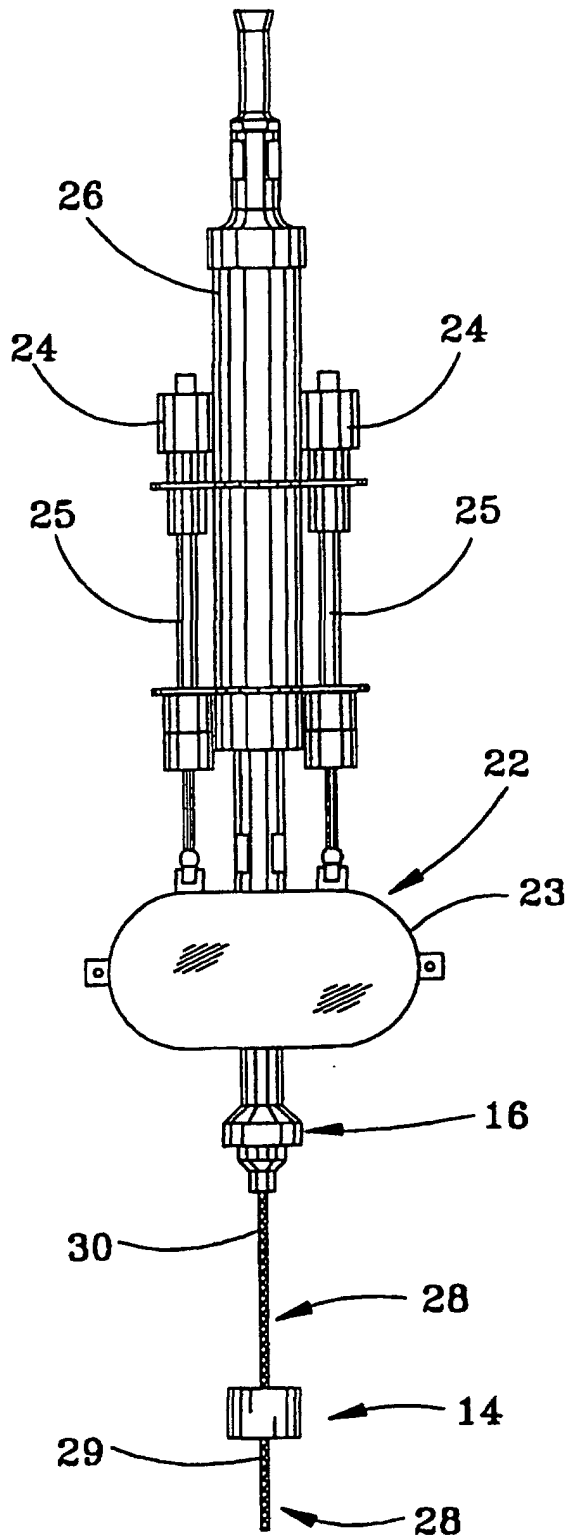

FIG. 3

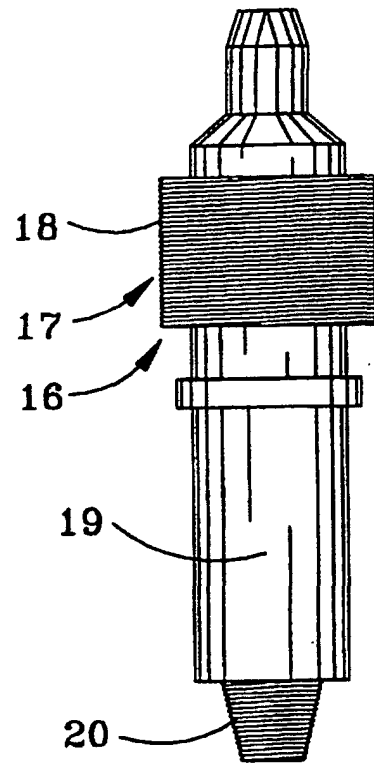

FIG. 7

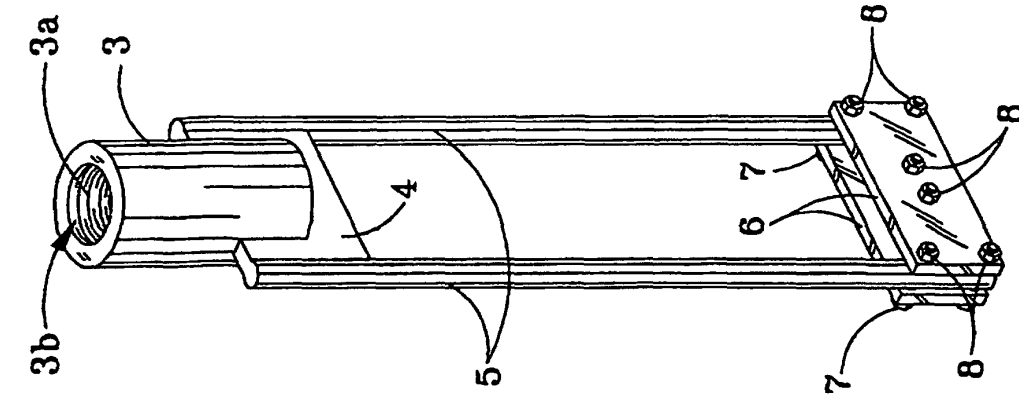

FIG. 6

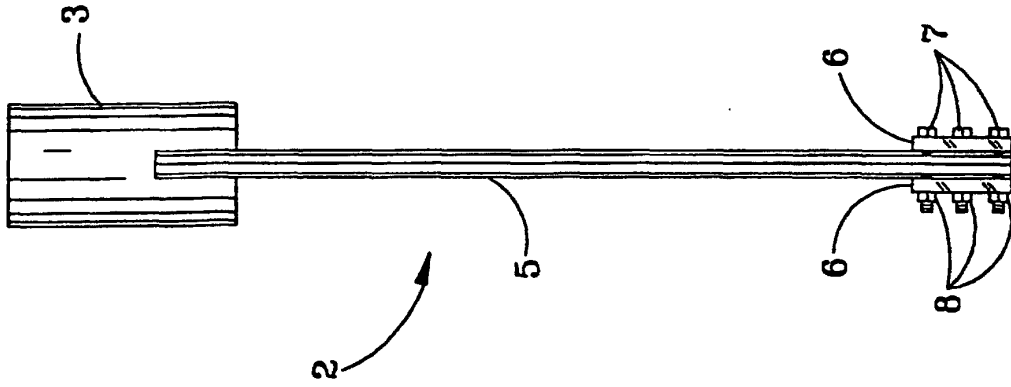

FIG. 5

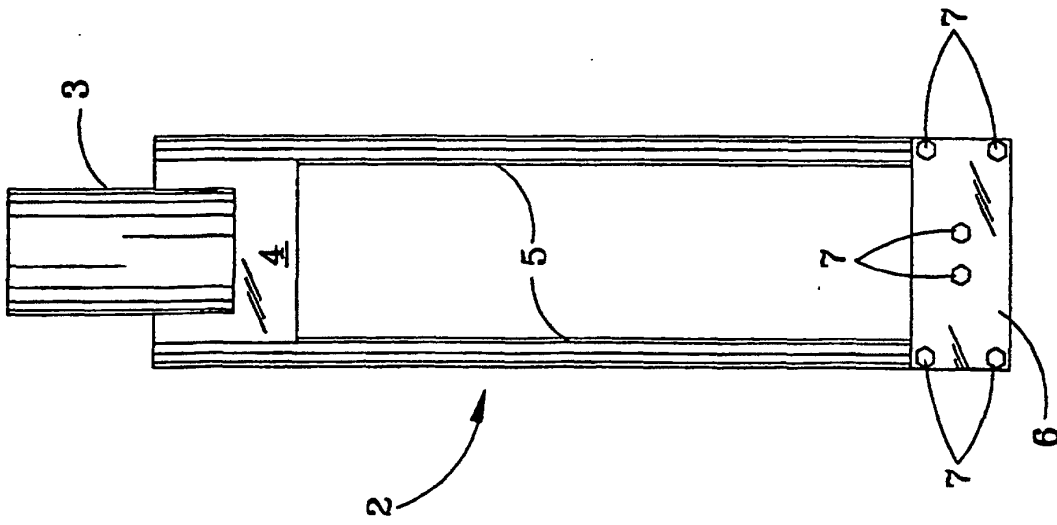

FIG. 4