



US00D715838S

(12) **United States Design Patent**  
Nagakura et al.

(10) **Patent No.:** US D715,838 S

(45) **Date of Patent:** \*\* Oct. 21, 2014

(54) **CYLINDER HEAD FOR INTERNAL COMBUSTION ENGINES**

(71) Applicant: **Honda Motor Co., Ltd.**, Tokyo (JP)

(72) Inventors: **Masaki Nagakura**, Wako (JP); **Satoshi Nakamura**, Wako (JP)

(73) Assignee: **Honda Motor Co., Ltd.**, Tokyo (JP)

(\*\*) Term: **14 Years**

(21) Appl. No.: **29/483,939**

(22) Filed: **Mar. 4, 2014**

(30) **Foreign Application Priority Data**

Sep. 4, 2013 (JP) ..... 2013-020455

(51) **LOC (10) Cl.** ..... **15-01**

(52) **U.S. Cl.**  
USPC ..... **D15/5**

(58) **Field of Classification Search**

CPC ..... F02F 1/40; F02F 1/243; F02F 1/24; F02F 1/42; F02F 1/242; F02F 11/002; F02F 1/38; F02F 7/006; F02F 1/4264; F02F 1/36; F02F 1/4285; F02F 1/02; F02F 11/00; F02F 1/002; F02F 1/16; F02F 2001/245; F02F 1/4214; F02B 1/04; F02B 3/06  
USPC ..... D15/1-6  
See application file for complete search history.

(56) **References Cited**

U.S. PATENT DOCUMENTS

5,535,714 A \* 7/1996 Aoyama et al. .... 123/193.5  
6,295,963 B1 \* 10/2001 Kollock et al. .... 123/193.5  
7,367,294 B2 \* 5/2008 Rozario et al. .... 123/41.82 R  
7,784,442 B2 \* 8/2010 Lester et al. .... 123/193.5

D701,885 S \* 4/2014 Clark et al. .... D15/5  
D705,269 S \* 5/2014 Tachikawa et al. .... D15/5  
8,714,128 B2 \* 5/2014 Galeazzi et al. .... 123/193.5  
2007/0215074 A1 \* 9/2007 Rozario et al. .... 123/41.82 R  
2012/0012073 A1 \* 1/2012 Brewer et al. .... 123/41.74  
2012/0031355 A1 \* 2/2012 Romblom ..... 123/58.1  
2012/0227686 A1 \* 9/2012 D'Anna et al. .... 123/41.82 R  
2012/0227687 A1 \* 9/2012 Galeazzi et al. .... 123/41.82 R  
2013/0055971 A1 \* 3/2013 Brewer et al. .... 123/41.82 R

\* cited by examiner

*Primary Examiner* — John Windmuller

*Assistant Examiner* — Ania Aman

(74) *Attorney, Agent, or Firm* — Westerman, Hattori, Daniels & Adrian, LLP

(57) **CLAIM**

The ornamental design for a cylinder head for internal combustion engines, as shown and described.

**DESCRIPTION**

FIG. 1 is a front elevational view of the cylinder head for internal combustion engines according to our invention; FIG. 2 is a rear elevational view thereof; FIG. 3 is a top plan view thereof; FIG. 4 is a bottom plan view thereof; FIG. 5 is a right side elevational view thereof; FIG. 6 is a left side elevational view thereof; FIG. 7 is a front perspective view thereof, as seen from the lower right side; FIG. 8 is a front perspective view thereof, as seen from the lower left side; FIG. 9 is a rear perspective view thereof, as seen from the upper right side; and, FIG. 10 is a rear perspective view thereof, as seen from the upper left side.

**1 Claim, 10 Drawing Sheets**

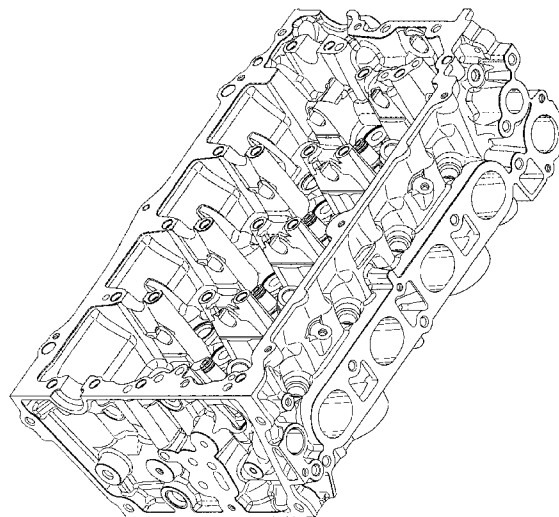

FIG. 1

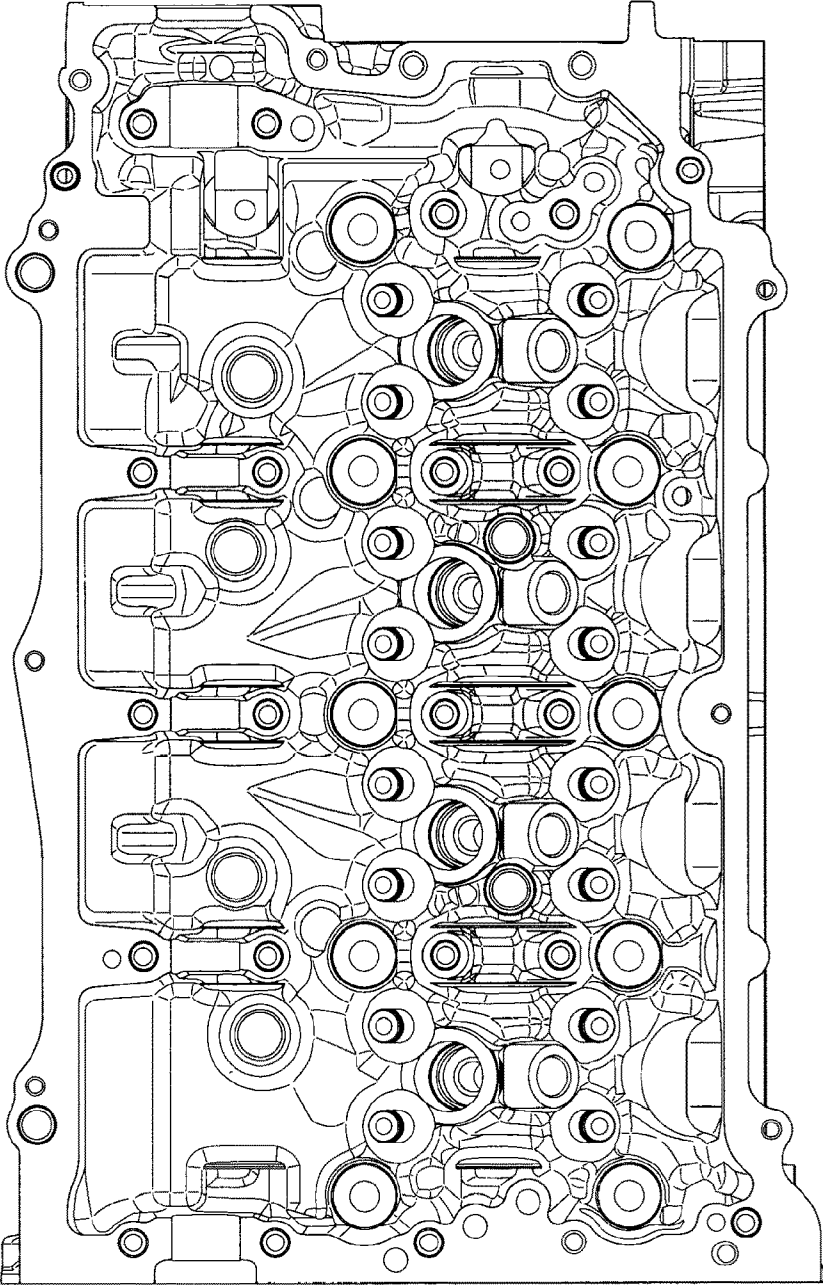

FIG.2

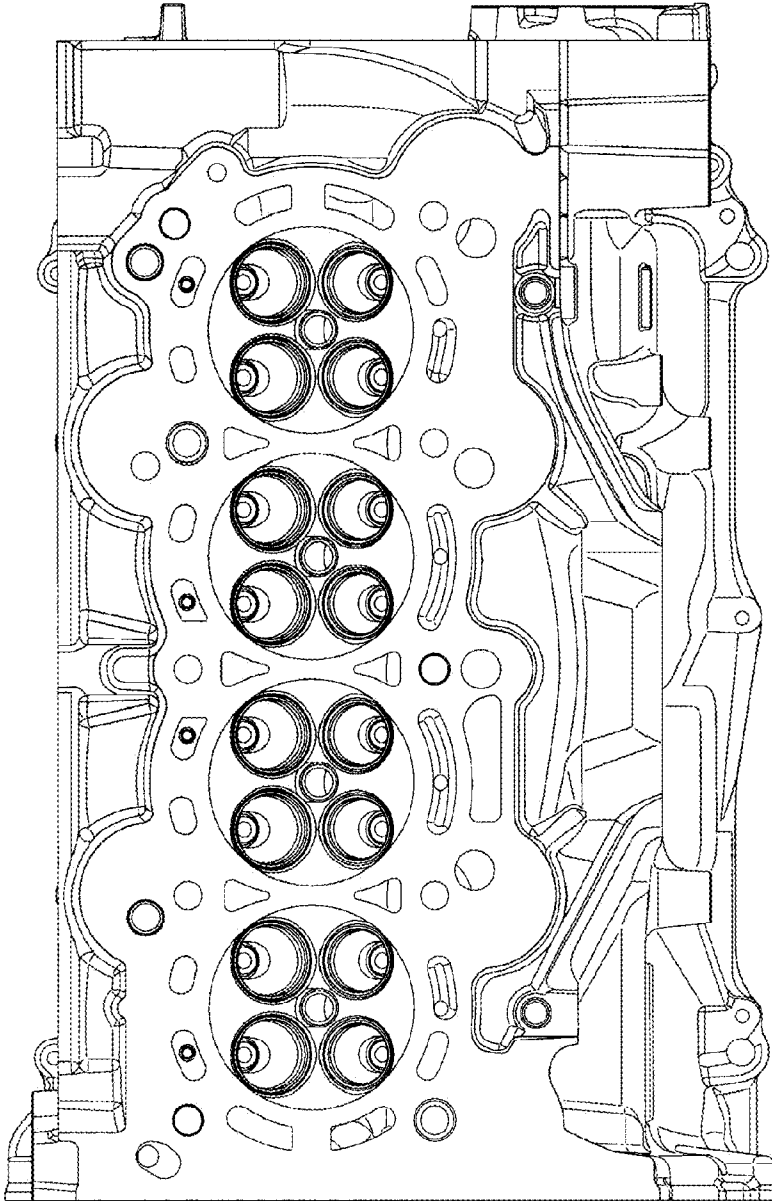

FIG.3

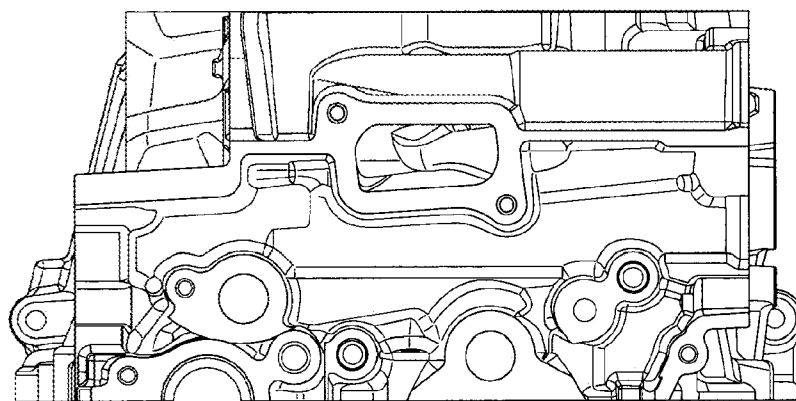

FIG.4

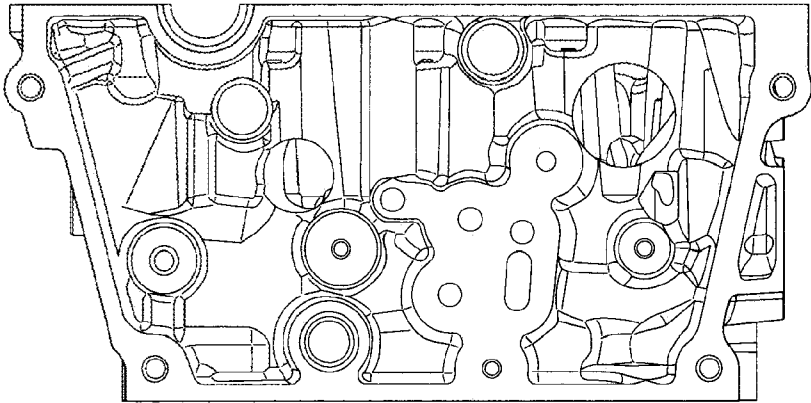

FIG.5

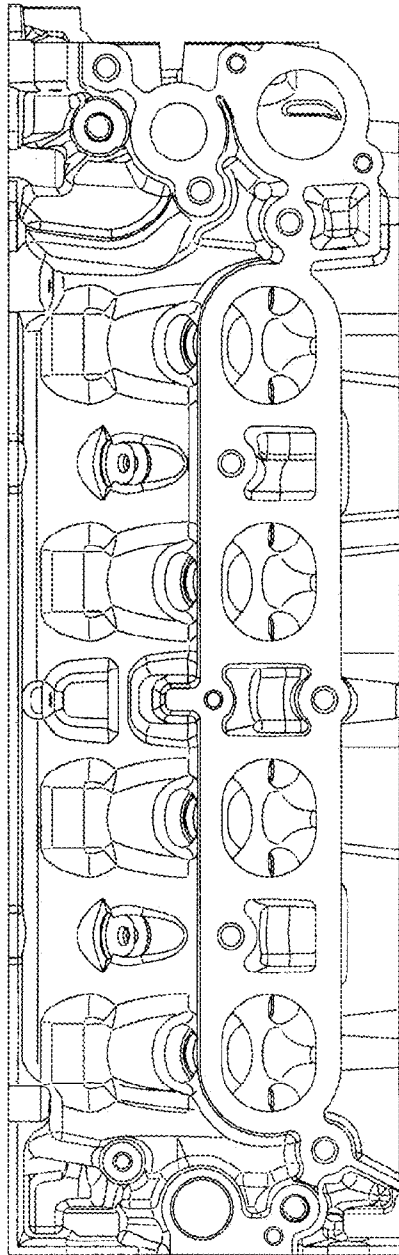

FIG.6

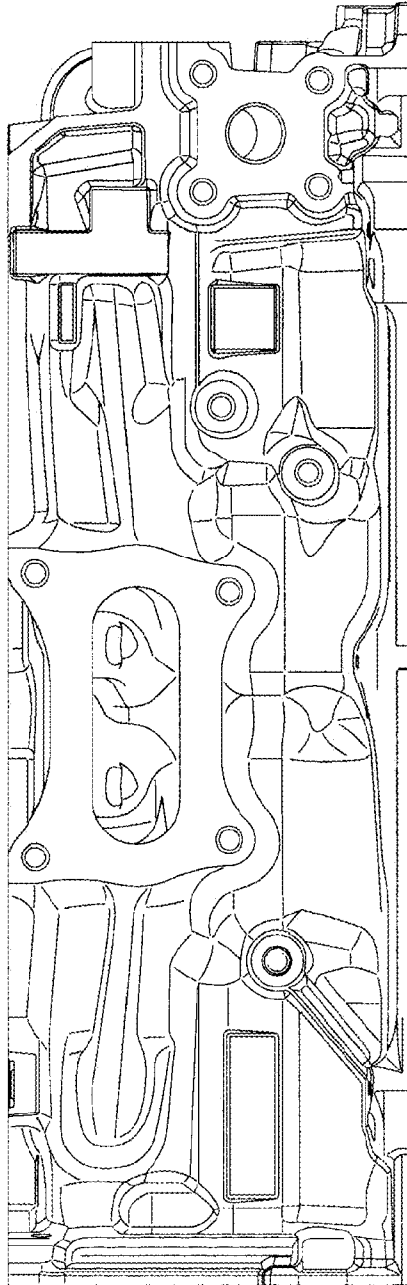

FIG. 7

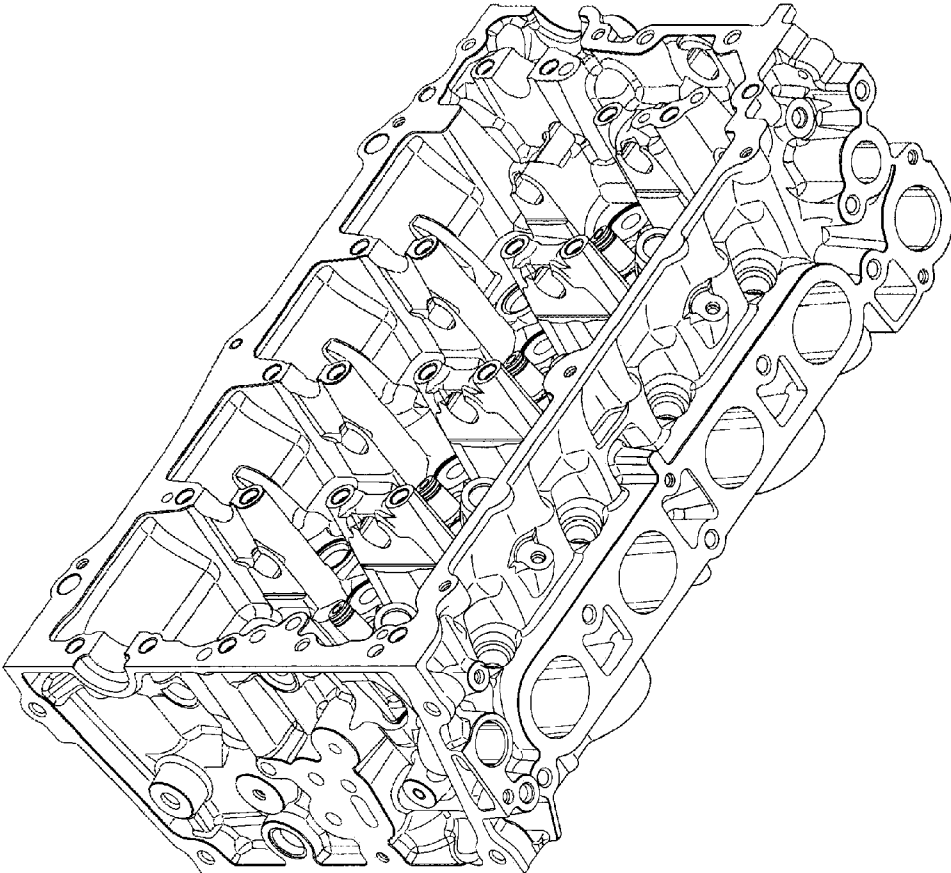

FIG.8

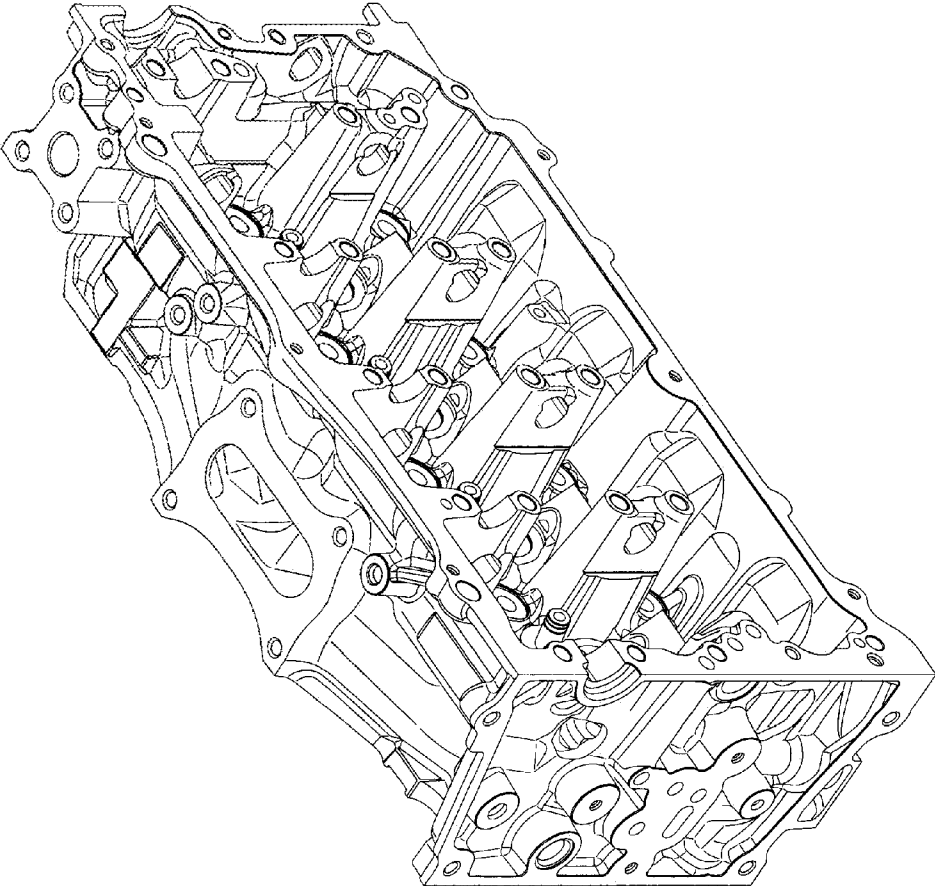

FIG.9

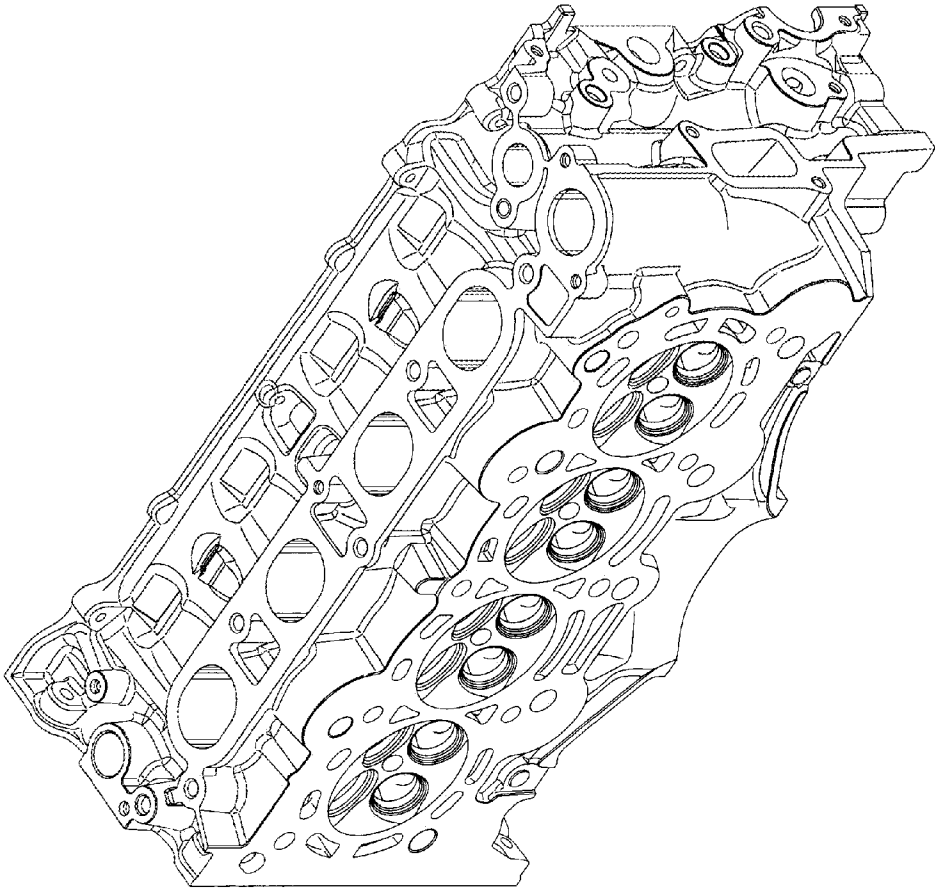

FIG.10

