



(11) **EP 1 890 096 A2**

(12) **EUROPEAN PATENT APPLICATION**

(43) Date of publication:
20.02.2008 Bulletin 2008/08

(51) Int Cl.:
F25B 43/00 (2006.01)

(21) Application number: **07016164.1**

(22) Date of filing: **17.08.2007**

(84) Designated Contracting States:
AT BE BG CH CY CZ DE DK EE ES FI FR GB GR HU IE IS IT LI LT LU LV MC MT NL PL PT RO SE SI SK TR
Designated Extension States:
AL BA HR MK YU

- **Lee, Hongyeol**
Asan-si,
Chungcheongnam-do, 336-864 (KR)
- **Kwak, Hyosang**
Cheonan-si,
Chungcheongnam-do, 330-835 (KR)
- **Kim, Youngrae**
Asan-si,
Chungcheongnam-do, 336-864 (KR)

(30) Priority: **18.08.2006 KR 20060078186**

(71) Applicant: **Doowon Climate Control Co., Ltd**
336-864 Chungcheongnam-do (KR)

(74) Representative: **Köhler, Walter et al**
Louis, Pöhlau, Lohrentz
Patentanwälte
Postfach 30 55
90014 Nürnberg (DE)

(72) Inventors:
• **Sung, Kichun**
Asan-si,
Chungcheongnam-do, 336-864 (KR)

(54) **Accumulator of air conditioner**

(57) The present invention provides an accumulator of an air conditioner, in which a coolant outlet pipe is a dual pipe (36) with an internal pipe (36b) and an external pipe (36a), a return cap (56) is combined to the lower end of the dual pipe (36), and a gas coolant flows from the upper portion inside a tank (20) through a gas coolant inlet between the internal pipe and the external pipe, turns into the internal pipe at the return cap (56), and then continues flowing through the gas coolant outlet to an outer pipe. Therefore, the accumulator can be manufactured from a small tank, so that it can be easily mounted in a small space with high liquid-vapor separating performance and pressure resistance.

FIG. 3

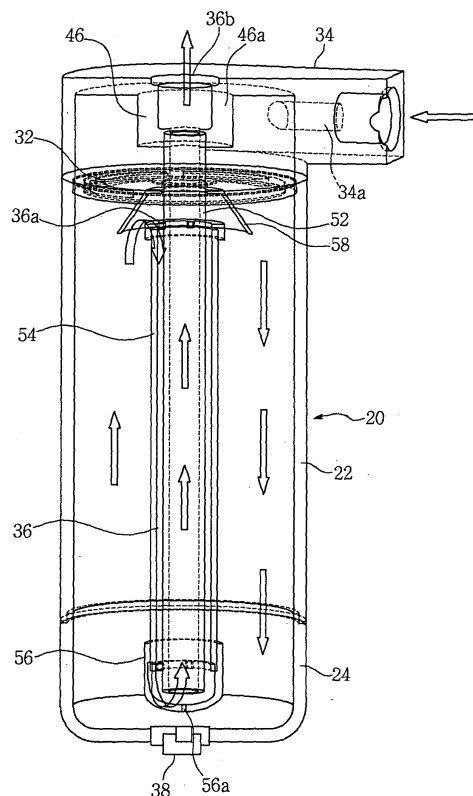

EP 1 890 096 A2

Description

BACKGROUND OF THE INVENTION

1. Field of the Invention

[0001] The present invention relates to an accumulator of an air conditioner, and more particularly, to an accumulator of an air conditioner that can be formed of a small tank, so that it can be easily mounted in a small space and is improved in vapor-liquid separating performance with high pressure resistance.

2. Description of the Related Art

[0002] In general, in an air conditioner for air-conditioning of a vehicle, an air-conditioning cycle is formed by a coolant circulating through the compressor, condenser, throttle valve, and evaporator, and an air-conditioning cycle with a coolant that is compressed at a supercritical pressure above a critical pressure by the compressor is called a supercritical air-conditioning cycle. In general, in supercritical air-conditioning cycles, a coolant does not change phase in heat-discharging process into the atmosphere; therefore, a heat discharger for this process is called a gas cooler, not a condenser.

[0003] In these supercritical air-conditioning cycles, because it is difficult for the coolant discharged out of the evaporator to form superheat due to the characteristics of the coolant, liquid coolant flows into the compressor, which causes liquid back and damage to the condenser. In order to prevent these problems, an accumulator is provided to separate liquid and vapor, and then send only the gas coolant to the condenser.

[0004] An air conditioner having the supercritical air-conditioning cycle is, as shown in FIG. 1, a system including a compressor 1, a condenser 2 (gas cooler), a throttle valve 3, an evaporator 4, from which the air-conditioning cycle is completed, an accumulator 5 that separates the coolant out of the evaporator into gas and liquid, and an internal heat exchanger 6 that causes a heat exchange between the coolant out of the condenser 2 (gas cooler) and the coolant out of the accumulator 5.

[0005] According to the accumulator 5 in the related art, as shown in FIG. 2, a coolant that flows through a coolant inlet pipe 11 into the upper space inside a tank 12 passes through a section plate 13 and is then separated into oil, a liquid coolant, and a gas coolant, depending on the specific gravity. Only the gas coolant flows through a gas coolant inlet 14a of a coolant pipe 14 in the tank 12 into the coolant pipe and is sent to the compressor 1 through a gas coolant outlet 14b of the coolant pipe 14, which prevents liquid back.

[0006] The coolant pipe 14 has a pipe line that is bent down from the gas coolant inlet 14a under the section pipe 13, extends to the gas coolant outlet 14b above the tank 12. An oil return hole 14c is formed at the lower portion inside the tank 12 to allow the oil for the compres-

sor (oil separated from the coolant) to flow into and circulate through the coolant pipe 14.

[0007] However, in the accumulator in an air-conditioner in the related art, it is required to keep the size of the tank larger than a predetermined size because a part of the coolant pipe bends according to the pipe line of the coolant pipe provided inside the tank. Therefore, a predetermined-sized space should be ensured in the engine room of a vehicle to mount the accumulator in the vehicle, which causes a problem when mounting in a small space.

[0008] In order to overcome the problems, a structure in which an inlet pipe is formed at the upper portion of a tank and a gas coolant outlet of a coolant pipe is formed at the lower portion of the tank has been proposed; however, the accumulator having the above structure relatively required more bending and length for a counter pipe outside the tank.

[0009] Further, it was difficult to achieve high efficiency in separation, because a fluid (coolant) composed of oil, a liquid coolant, and a gas coolant was separated by only depending on the specific gravity.

SUMMARY OF THE INVENTION

[0010] Accordingly, in order to overcome the above problems, an object of the present invention is to provide an accumulator of an air conditioner that can be formed of a small tank, so that it can be easily mounted in a small space and is improved in vapor-liquid separating performance with high pressure resistance.

[0011] Another object of the invention is to provide a compact-sized air-conditioning system including the functions of an internal heat exchanger that makes heat exchange between a high-temperature high-pressure side and a low-temperature low-pressure side by fitting high-pressure pipes with each other in the longitudinal direction of a dual pipe such that the internal heat exchange can be integrally provided in an accumulator.

[0012] In order to achieve the objects of the invention, an accumulator of an air conditioner according to an embodiment of the invention includes: a tank; a coolant intake that is formed at the upper portion inside the tank; and a coolant outlet pipe that is vertically disposed in the tank to discharge a gas coolant separated from a coolant that has flowed in the tank, and has a gas coolant outlet at the upper portion of the tank, in which the coolant outlet pipe is a dual pipe with an internal pipe and an external pipe, a return cap is combined to the lower end of the dual pipe, the gas coolant flows from the upper portion inside the tank through a gas coolant inlet between the internal pipe and the external pipe, turns into the internal pipe at the return cap, and then continues flowing through the gas coolant outlet to an outer pipe.

[0013] In order to achieve the other objects of the invention, an accumulator of an air conditioner according to an embodiment of the invention further includes: a high-pressure coolant inlet pipe that longitudinally surrounds a part of the outside of the external pipe of the

coolant outlet pipe; and a high-pressure coolant outlet pipe that longitudinally surrounds the other part of the outside of the external pipe of the coolant outlet pipe, in which a connection cap is combined to the lower ends of the high-pressure coolant inlet pipe and the high-pressure coolant outlet pipe such that the coolant that flows inside through the high-pressure coolant inlet pipe turns into the high-pressure coolant outlet pipe at the connection cap, and the coolant outlet pipe is used for outflow of a low-pressure gas coolant.

BRIEF DESCRIPTION OF THE DRAWINGS

[0014] The above and other features and advantages of the present invention will become more apparent by describing in detail preferred embodiments thereof with reference to the attached drawings in which:

FIG. 1 is a view showing a system of an air conditioner- including an accumulator;

FIG. 2 is a schematic view showing an accumulator of an air conditioner in the related art;

FIG. 3 is a schematic view showing an accumulator of an air conditioner according to an embodiment of the invention;

FIG. 4 is a perspective view showing an upper body of FIG. 3;

FIG. 5 is a perspective view illustrating combination of a dual body with the upper body of the accumulator of FIG. 3;

FIG. 6 is a perspective view illustrating combination of another exemplary upper body of FIG. 5;

FIG. 7 is a perspective view of the dual pipe and the upper body seen from above;

FIG. 8 is a perspective view illustrating combination of another exemplary liquid coolant block pipe of FIG. 6;

FIG. 9 is a view illustrating the configuration of another exemplary accumulator of an air conditioner according to the embodiment of the invention;

FIG. 10 is a view illustrating the configuration of another exemplary accumulator of an air conditioner according to the embodiment of the invention;

FIG. 11 is a cross-sectional view showing the lower portion of the accumulator of an air conditioner according to the embodiment of the invention;

FIG. 12 is a cross-sectional view showing the accumulator of an air conditioner with a filter in FIG. 11;

FIG. 13 is a view showing the portion (lower portion) where an explosion means of the accumulator of an air conditioner according to the embodiment of the invention is provided;

FIG. 14 is a graph illustrating liquid-vapor separating performance to the diameter of a tank equipped with the dual pipe according to the embodiment of the invention;

FIG. 15 is a graph illustrating pressure resistance to the diameter of a tank including the dual pipe accord-

ing to the embodiment of the invention;

FIG. 16 is a partial cross-sectional view showing an accumulator of an air conditioner according to another embodiment of the invention;

FIG. 17 is a perspective view showing a curved thin tube (heat exchanging portion) of a high-pressure coolant inlet pipe and a high-pressure coolant outlet pipe of FIG. 16;

FIG. 18 is a perspective view showing another exemplary curved thin tube (heat exchanging portion) of a high-pressure coolant inlet pipe and a high-pressure coolant outlet pipe of FIG. 16; and

FIG. 19 is a perspective view showing another exemplary curved thin tube (heat exchanging portion) of a high-pressure coolant inlet pipe and a high-pressure coolant outlet pipe of FIG. 16.

DESCRIPTION OF THE PREFERRED EMBODIMENTS

[0015] Hereinafter, a detailed description will be given of the present invention with reference to the accompanying drawings.

First Embodiment

[0016] FIG. 3 is a view showing the configuration of an accumulator of an air conditioner according to a first embodiment of the invention. As shown in FIG. 3, according to the accumulator, a section plate 32 is disposed at the upper portion inside a tank 20, an upper body 34 with a coolant intake 34a that allows a coolant to flow into the upper portion inside the tank is combined to the upper end of the tank 20, and a dual pipe 36 is vertically disposed under the inside bottom of the upper body 34 in the tank 20 to discharge a gas coolant separated from the coolant inside the tank.

[0017] In the tank 20, a lower part 24 of the tank is combined to a tank body 22 by welding etc. or the lower part 24 of the tank is integrally formed with the tank body 22 by forging and combined with the upper body 34.

[0018] An explosion means 38 with an explosion plate that explodes under a predetermined pressure to rapidly discharge a coolant outside at an abnormal high pressure is provided at the bottom of the lower part 24 of the tank.

[0019] In the upper body 34, as shown in FIG. 4, a side protrusion 44 with a hole for a coolant to flow inside is formed on the outside of a cylinder 42. In detail, a hole that forms the coolant intake 34a is formed at the side of the side protrusion 44 to easily separate liquid and vapor from the coolant that flows into the upper portion inside the tank 20 by guiding the coolant such that it flows inside while circumferentially rotating.

[0020] Further, a protrusion 46 with a round side 46a is formed at the bottom of the upper body 34 where an internal pipe of the dual pipe 36 (described below) is connected, in order to easily induce a cyclone by allowing the coolant that flows into the tank through the coolant intake 34a to hit the round side and easily rotate. A gas

coolant outlet 36b through which a gas coolant separated from the coolant in the tank is discharged is formed at the center of the protrusion 46.

[0021] FIG. 5 is a perspective view showing an example in which the dual pipe 36 is connected to the inside bottom of the upper body 34. As shown in FIG. 5, the internal pipe of the dual pipe 36 (described below) is communicated with the gas coolant outlet 36b of the upper body 34 through the protrusion 46.

[0022] On the other hand, as shown in FIGS. 6 and 7, an upper body 134 that is combined to the upper end of the tank 20 may be formed of a cylindrical block of a predetermined thickness. A coolant intake 134a that allows a coolant to flow into the tank 20 and a gas coolant outlet 136b through which a gas coolant is discharged from the inside of the tank are vertically formed through the upper body 134 of cylindrical block.

[0023] As shown in FIGS. 5 to 7, the section plate 32 is disposed in contact with the lower end of the upper body 34 or fitted on the internal pipe of the dual pipe 36 at a predetermined distance from the upper body 134. A plurality of long groove-shaped holes 32a is circumferentially formed through the section plate 32 to allow a coolant to flow down into the tank 20. A small filter (not shown) is provided on the plane (generally upper surface) of the section plate 32 and fixed by ring-shaped clips 48, 49 that are fitted on the outer and inner circumferences of the section plate 32, respectively.

[0024] The dual pipe 36 is a pipe with an internal pipe 52 that is communicated with the gas coolant outlets 36b, 136b and an external pipe 54 that is connected to a gas coolant inlet 36a. A return cap 56 is combined to the lower end of the dual pipe 36 and the gas coolant flows from the upper portion inside the tank 20 into the gas coolant inlet 36a between the internal pipe 52 and the external pipe 54, turns into the internal pipe 52 at the return cap 56, and continues flowing to an outer pipe through the gas coolant outlets 36b, 136b.

[0025] The coolant intakes 34a, 134a are formed above the section plate 32, the gas coolant inlet 36a is formed under the section pipe 32, and a liquid coolant block pipe 58 that surrounds the gas coolant inlet 36a to prevent the liquid coolant from flowing into the coolant outlet pipe (dual pipe) through the gas coolant inlet 36a is combined to the lower surface of the section plate 32.

[0026] The liquid coolant block pipe 58 is a cone-shaped pipe with the top cut and the lower end open, or as shown in FIG. 8, may be a liquid coolant block pipe 158 that is a cylindrical pipe with the lower end open. The liquid coolant block pipes 58, 158 are fixed by the ring-shaped clip 49 or other specific fixing means.

[0027] It is preferable for the passage area defined by a gap c between the liquid coolant block pipes 58, 158 and the external pipe 54 of the coolant outlet pipe (dual pipe) to be larger than the passage area between the internal pipe 52 and the external pipe 54 of the coolant outlet pipe.

[0028] The dual pipe 36 is an extruded dual pipe with

the internal pipe 52 and external pipe 54 that are integrally formed, or the internal pipe 52 and the external pipe 54 may be formed by combining a separate internal pipe and external pipe.

[0029] On the other hand, as shown in FIG. 9, the coolant intake 134a may extend down through the section plate 32 by an inlet pipe 62 and the gas coolant inlet 36a may be formed above the section plate 32.

[0030] Further, as shown in FIG. 10, the coolant intake 34a (shown in FIG. 5) may extend to the upper portion of the section plate 32 by an inclined inlet pipe 162, in which the protrusion 46 shown in FIG. 5 is not needed and the other configuration is the same as in FIGS. 3 and 5.

[0031] FIG. 11 is a cross-sectional view showing the lower part 24 of the tank in which the return cap 56 is disposed. As shown in FIG. 11, an oil return hole 56a is formed through the return cap 56 to allow the oil for the compressor (oil separated from the coolant) to flow into and circulate through the coolant outlet pipe (dual pipe). The internal pipe 52 of the dual pipe 36 extends down more than the external pipe 54 to allow the oil to easily flow into the internal pipe 52.

[0032] On the other hand, as shown in FIG. 12, a filter 64 is provided over the return cap 56 to prevent any foreign substances from flowing into the internal pipe 52 through the oil return hole 56a. A filter 66 may be provided at the lower end of the internal pipe 52.

[0033] Further, as shown in FIG. 13, the oil that has flowed in the tank 20 is separated in to oil, a liquid coolant, and a gas coolant from the bottom of the tank and it is preferable to form the bottom of the tank under the return cap 56 deeper than other portions to easily collect and return the oil, in which the explosion means 38 shown in FIG. 3 is combined with the higher portion of the bottom of the tank.

[0034] The explosion means 38 is composed of an explosion plate 38a fixed to the bottom of the tank, a housing 38b of a vertical pipe and a horizontal pipe 38c that are sequentially connected to the explosion plate 38a. The explosion plate 38a is disposed between the machined surface of the lower part 24 of the tank and the housing 38b of vertical pipe.

[0035] In the accumulator of an air conditioner having the above configuration according to the embodiment of the invention, as indicated by the arrows in FIGS. 3 and 4, as the coolant that flows into the upper body 34 through the coolant intake 34a of the upper body 34. rotates along the wall and hits the protrusion 46, a liquid coolant is formed and flows down into the tank 20 and oil, a liquid coolant, and a gas coolant are separated. The gas coolant flows into the dual pipe 36, i.e. between the internal pipe 52 and the external pipe 54 through the gas coolant inlet 36a, turns into the internal pipe 52 at the return cap 56, and continues flowing up through the gas coolant outlet 36b to the outer pipe.

[0036] On the other hand, it is preferable for the accumulator to increase the diameter of the tank to increase

capacity; however, it is strongly required to reduce the outer diameter of the tank because it is restricted by space in a small space, such as an engine room of a vehicle, and it is needed to improve liquid-vapor separating performance and pressure resistance in the tank of an accumulator of a small diameter to solve the above-mentioned problems. In general, the tank of an accumulator requires larger capacity than a liquid receiver, so that the diameter of the tank is usually set at 60 mm or more.

[0037] FIG. 14 shows a graph illustrating liquid-vapor separating performance to the diameter of the tank equipped with a dual pipe according to the embodiment of the invention and FIG. 15 shows a graph illustrating pressure resistance to the diameter of the tank equipped with a dual pipe according to the embodiment.

[0038] As shown in FIG. 14, a region of a liquid coolant under normal operating condition appears when the ratio of a liquid coolant in the tank of the accumulator to the entire inside volume is 0.65 in a common liquid-vapor separating tank. Considering the amount of liquid coolant in the liquid-vapor separating tank that is needed in an air conditioner is at a minimum 250 cc to a maximum 800 cc, it can be seen from the graph that the liquid-vapor separating performance is good when the diameters are in the range of 30 mm to 60 mm.

[0039] Further, as shown in FIG. 15, for the range of minimum 250 cc to maximum 800 cc that is a reasonable range of capacity of a liquid-vapor separating tank that is improved in liquid-vapor separating performance, it can be seen from the graph that, in the supercritical cooling cycle under high pressure, tanks of 30 mm to 60 mm diameter shows relatively better characteristics in pressure resistance than a tank of 60 mm diameter in the related art.

Second Embodiment

[0040] An accumulator of an air conditioner according to a second embodiment of the invention has an integral internal heat exchanger. The accumulator of an air conditioner according to the first embodiment of the invention does not include an internal heat exchanger, but the accumulator of an air conditioner according to this embodiment of the invention includes an additional mechanism that flows a coolant for internal heat exchange into the tank and circulates it therein.

[0041] In the second embodiment of the invention, hereafter, in order to distinguish the coolant for internal heat exchange from the coolant that is separated into a liquid and a gas through the coolant outlet pipe, the coolant for internal heat exchange is referred to as a 'high-pressure coolant' and the coolant that is separated into a liquid and a gas through the coolant outlet pipe is referred to as a 'low-pressure coolant'.

[0042] As shown in FIG. 16, in an accumulator of an air conditioner according to the second embodiment of the invention, a low-pressure coolant inlet pipe 322

through which a low-pressure coolant flows is disposed at the upper portion inside a hollow tank 320 and a low-pressure coolant outlet pipe 324 is vertically disposed at the center inside the tank 320 to discharge a gas coolant separated from the coolant that has flowed in the tank.

[0043] Further, the high-pressure coolant inlet pipe 326 longitudinally covers a part of the outside of the low-pressure coolant outlet pipe 324 for heat exchange with the low-pressure coolant, and a high-pressure coolant outlet pipe 328 longitudinally covers the other part of the outside of the low-pressure coolant outlet pipe 324 for heat exchange with the low-pressure coolant while being communicated with the lower end of the high-pressure coolant inlet pipe 326.

[0044] The tank 320 is composed of a tank body 320a and a lower part 320b of the tank combined to the lower portion of the tank body 320a, or the tank body 320a and the lower part 320b of the tank may be integrally formed by forging and an upper body 321 is combined to the upper end of the tank body 320a. The tank 320 may be composed of the tank body 320a and the lower part 320b of the tank that are integrally formed.

[0045] The low-pressure coolant inlet pipe 322 is disposed with the upper portion passing through the upper body 321 and the outside of the lower portion having coolant injection hole 322a to inject a coolant to the high-pressure coolant inlet pipe 326, the high-pressure coolant outlet pipe 328, or the inside of the tank 320 and improve liquid-vapor separating performance while the injected coolant rotates.

[0046] The low-pressure outlet pipe 324 is a dual pipe with an internal pipe 324a and an external pipe 324b and a return cap 330 is combined to the lower end of the dual pipe. Accordingly, a gas coolant flows from the upper portion inside the tank 320 through a gas coolant inlet E1 between the internal pipe 324a and the external pipe 324b and turns into the internal pipe 324a at the return cap 330.

[0047] The upper and lower portions of the internal pipe 324a extends more than the upper and lower ends of the external pipe 324b and the upper end of the internal pipe 324a is positioned through the upper body 321. The gas coolant inlet E1 is formed under the upper body 321.

[0048] The low-pressure coolant outlet pipe 324 is an extruded dual pipe with the internal pipe 324a and the external pipe 324b that are integrally formed, or the internal pipe and the external pipe are formed by combining separate internal pipe with external pipe.

[0049] The high-pressure coolant inlet pipe 326 has an inlet 326a that is positioned through the upper body 321 and a heat exchanging portion 326b through which heat is exchanged with a low-pressure coolant in the tank 320. The high-pressure coolant outlet pipe 328 has an outlet 328a that is positioned through the upper body 321 and a heat exchanging portion 328b through which heat is exchanged with the low-pressure coolant in the tank 320.

[0050] As shown in FIG. 17, the heat exchanging por-

tions 326b, 328b of the high-pressure coolant inlet pipe 326 and the high-pressure coolant outlet pipe 328 are each formed of a thin tube that is curved in the width, direction and has a plurality of coolant passages H inside. The heat exchanging portions 326b, 328b are curved in an arc shape.

[0051] The inlet 326a of the high-pressure coolant inlet pipe 326 and the outlet 328a of the high-pressure coolant outlet pipe 328 are each formed of one coolant passage, and the inlet 326a and the outlet 328a are communicated with corresponding heat exchanging portions 326b, 328b formed of a plurality of coolant passages.

[0052] The curved thin tube (heat exchanging portions 326b, 328b) is formed in a curved thin tube shape by extrusion without a post-machining.

[0053] The outsides of the high-pressure coolant pipes 326, 328 and the low-pressure coolant outlet pipe 324 are joined and arranged such that the coolants in the high-pressure coolant pipes 326, 328 exchange heat with the coolant in the low-pressure coolant outlet pipe 324.

[0054] Heat conductive fins 332 are provided on the outside of the curved thin tube (heat exchanging portions 326b, 328b) to increase heat exchange efficiency.

[0055] The lower ends of the high-pressure coolant inlet pipe 326 and the high-pressure coolant outlet pipe 328 are communicated by a connection cap 334. The connection cap 334 may be integrally formed with the return cap 330.

[0056] An oil return hole 330a is formed through the return cap 330 to allow the oil for the compressor (oil separated from the coolant) to flow into and circulate through the internal pipe 324a of the low-pressure coolant outlet pipe 324. A filter (not shown) may be provided over the return cap 330 to prevent any foreign substances to flow inside through the oil return hole 330a.

[0057] FIG. 18 shows another embodiment of the heat exchanging portion of the high-pressure coolant inlet pipe 326 and the high-pressure coolant outlet pipe 328 of the invention. Protruding heat conductive fins 432 are integrally formed, on the curved outside, with heat exchanging portions 426b, 428b of this embodiment.

[0058] FIG. 19 shows another embodiment of the heat exchanging portion of the high-pressure coolant inlet pipe 326 and the high-pressure coolant outlet pipe 328 of the invention. Individual heat conductive fins 532 of offset fins with folds are attached to the curved outside of heat exchanging portions 526b, 528b of the invention. The heat conductive fins 532 of offset fins with folds increases the heat exchange rate by increasing the heat exchange area.

[0059] According to the accumulator equipped with an integral internal heat exchanger of an air conditioner having the above configuration of the invention, as shown by arrows in FIG. 16, a low-pressure coolant that flows from the evaporator 4 (shown in FIG. 1) into the upper portion inside the tank 320 through the low-pressure coolant inlet pipe 322 is separated into oil, a liquid coolant, and a gas coolant while flowing down.

[0060] The liquid-vapor separating performance is increased by injecting the coolant through the coolant injection hole 322a to the high-pressure coolant inlet pipe 326, the high-pressure coolant outlet pipe 328, or the inside of the tank 320.

[0061] The separated gas coolant flows inside through the gas coolant inlet E1 between the internal pipe 324a and external pipe 324b of the low-pressure coolant outlet pipe 324, turns up into the internal pipe 324a at the return cap 330, and then continues flowing to the outer pipe toward the compressor 1 (shown in FIG. 1). The stagnant oil for the compressor at the lower portion in the tank 320 returns to the compressor through the oil return hole 330a.

Further, the high-pressure coolant that flows from the condenser 2 (gas cooler) (shown in FIG. 1) into the high-pressure coolant inlet pipe 326 exchanges heat with the gas coolant in the low-pressure coolant outlet pipe 324 and the low-pressure coolant in the tank 320 while passing through the heat exchanging portion 326b, exchanges heat with the gas coolant in the low-pressure outlet pipe 324 and the low-pressure coolant in the tank 320 while passing through the heat exchanging portion 328b of the high-pressure coolant outlet pipe 328 across the connection cap 334, and then continues flowing through the outlet 328a of the high-pressure coolant outlet pipe 328 to the outer pipe toward the throttle valve 3 (shown in FIG. 1).

An accumulator of an air conditioner according to an embodiment of the invention can be formed of a small tank, so that it can be easily mounted in a small space and is improved in vapor-liquid separating performance with high pressure resistance.

Further, according to an accumulator of an air conditioner according to another embodiment of the invention, an internal heat exchanger is integrally provided in the accumulator, such that system efficiency is increased by increase in heat exchange efficiency inside the body of the accumulator. Further, the internal heat exchanger is integrally provided without providing a specific internal heat exchanger outside, such that the coolant inlet and outlet are formed at the upper portion of the body of the accumulator and piping is easy.

Although the preferred embodiments of the present invention have been disclosed for illustrative purposes, those skilled in the art will appreciate that various modifications, additions and substitutions are possible, without departing from the scope and spirit of the invention as disclosed in the accompanying claims.

Claims

1. An accumulator of an air conditioner, comprising:
 - a tank;
 - a coolant intake that is formed at the upper portion inside the tank; and

a coolant outlet pipe that is vertically disposed in the tank to discharge a gas coolant separated from a coolant that has flowed in the tank, and has a gas coolant outlet at the upper portion of the tank,

wherein the coolant outlet pipe is a dual pipe with an internal pipe and an external pipe, and a return cap is combined to the lower end of the dual pipe, the gas coolant flows from the upper portion inside the tank through a gas coolant inlet between the internal pipe and the external pipe, turns into the internal pipe at the return cap, and then continues flowing through the gas coolant outlet to an outer pipe.

2. The accumulator of an air conditioner as set forth in claim 1, wherein the coolant intake is formed above a section plate disposed at the upper portion inside the tank, the gas coolant inlet is formed under the section plate, and a liquid coolant block pipe that surrounds the gas coolant inlet to prevent a liquid coolant from flowing into the coolant outlet pipe through the gas coolant inlet is formed under the section plate.
3. The accumulator of an air conditioner as set forth in claim 2, wherein the liquid coolant block pipe is a cone-shaped pipe with the top cut and the lower end open.
4. The accumulator of an air conditioner as set forth in claim 2, wherein the liquid coolant block pipe is a cylindrical pipe with the lower end open.
5. The accumulator of an air conditioner as set forth in claim 2, wherein the passage area defined by a gap between the liquid coolant block pipe and the external pipe of the coolant outlet pipe is larger than the passage area between the internal pipe and external pipe of the coolant outlet pipe.
6. The accumulator of an air conditioner as set forth in claim 1, wherein the coolant inlet extends to the lower portion of the section plate and the gas coolant inlet pipe is formed above the section plate.
7. The accumulator of an air conditioner as set forth in claim 1, wherein an upper body that has the coolant intake and a gas coolant outlet that is formed by connection with the internal pipe of the dual pipe is combined to the upper end of the tank.
8. The accumulator of an air conditioner as set forth in claim 7, wherein a coolant inlet of the upper body is formed at the side of the upper body and communicated with the coolant intake to easily separate liquid

and vapor from a coolant that flows into the upper portion inside the tank by circumferentially rotating the coolant.

- 5 9. The accumulator of an air conditioner as set forth in claim 8, wherein a protrusion with a round side is formed at the bottom of the upper body where the internal pipe of the dual pipe is connected, in order to easily induce a cyclone by allowing the coolant that flows into the tank through the coolant intake to hit the round side and easily rotate.
- 10 10. The accumulator of an air conditioner as set forth in claim 1, wherein an explosion plate that explodes under a predetermined pressure to rapidly discharge a coolant outside at an abnormal high pressure is provided at lower portion of the tank.
- 15 11. The accumulator of an air conditioner as set forth in claim 1, wherein an oil return hole 14c is formed in the return cap to allow oil for a compressor (oil separated from the coolant) to flow into and circulate through the coolant outlet pipe.
- 20 12. The accumulator of an air conditioner as set forth in claim 11, wherein a filter is provided to the return cap to prevent any foreign substances from flowing inside through the oil return hole.
- 25 13. The accumulator of an air conditioner as set forth in claim 11, wherein the bottom of the tank under the return cap is formed deeper than other portions to easily collect and recover the oil.
- 30 14. The accumulator of an air conditioner as set forth in claim 12, wherein the bottom of the tank under the return cap is formed deeper than other portions to easily collect and recover the oil.
- 35 15. The accumulator of an air conditioner as set forth in claim 1, wherein the diameter of the tank of the accumulator is in the range of 30 mm to 60 mm so that the accumulator is mounted in a small space with high liquid-vapor separating performance and pressure resistance.
- 40 16. The accumulator of an air conditioner as set forth in claim 1, further comprising:
 - 45 a high-pressure coolant inlet pipe that longitudinally surrounds a part of the outside of the external pipe of the coolant outlet pipe; and
 - 50 a high-pressure coolant outlet pipe that longitudinally surrounds the other part of the outside of the external pipe of the coolant outlet pipe,
- 55

wherein a connection cap is combined to the lower ends of the high-pressure coolant inlet pipe and the

high-pressure coolant outlet pipe such that the coolant that flows inside through the high-pressure coolant inlet pipe turns into the high-pressure coolant outlet pipe at the connection cap.

5

- 17.** The accumulator of an air conditioner as set forth in claim 16, wherein the high-pressure coolant inlet pipe and the high-pressure coolant outlet pipe each have a curved thin tube with a plurality of coolant passage inside. 10
- 18.** The accumulator of an air conditioner as set forth in claim 17, wherein the curved insides of the curved thin tubes is joined to the outside of the external pipe of the coolant outlet pipe so that the coolant in the coolant outlet pipe exchanges heat with the coolants in the high-pressure coolant inlet pipe and the high-pressure coolant outlet pipe. 15
- 19.** The accumulator of an air conditioner as set forth in claim 17, wherein heat conductive fins are provided on the curved outside of the curved thin tube. 20
- 20.** The accumulator of an air conditioner as set forth in claim 19, wherein the heat conductive fins are integrally formed with the curved thin tube, protruding outside. 25
- 21.** The accumulator of an air conditioner as set forth in claim 19, wherein the heat conductive fin is an offset fin with folds. 30
- 22.** The accumulator of an air conditioner as set forth in claim 19, wherein the heat conductive fin is a flat fin that is inserted around the curved thin tube. 35
- 23.** The accumulator of an air conditioner as set forth in claim 19, wherein the curved thin tube is formed by being pressed in a curved thin tube shape without post-machining. 40
- 24.** The accumulator of an air conditioner as set forth in claim 16, wherein the connection cap is integrally formed with the return cap of the coolant outlet pipe. 45
- 25.** The accumulator of an air conditioner as set forth in claim 16, wherein the coolant intake is a pipe that is vertically disposed from the upper portion through the tank and has a coolant injection hole through the outside of the pipe to rotate an injected coolant. 50

55

FIG. 1

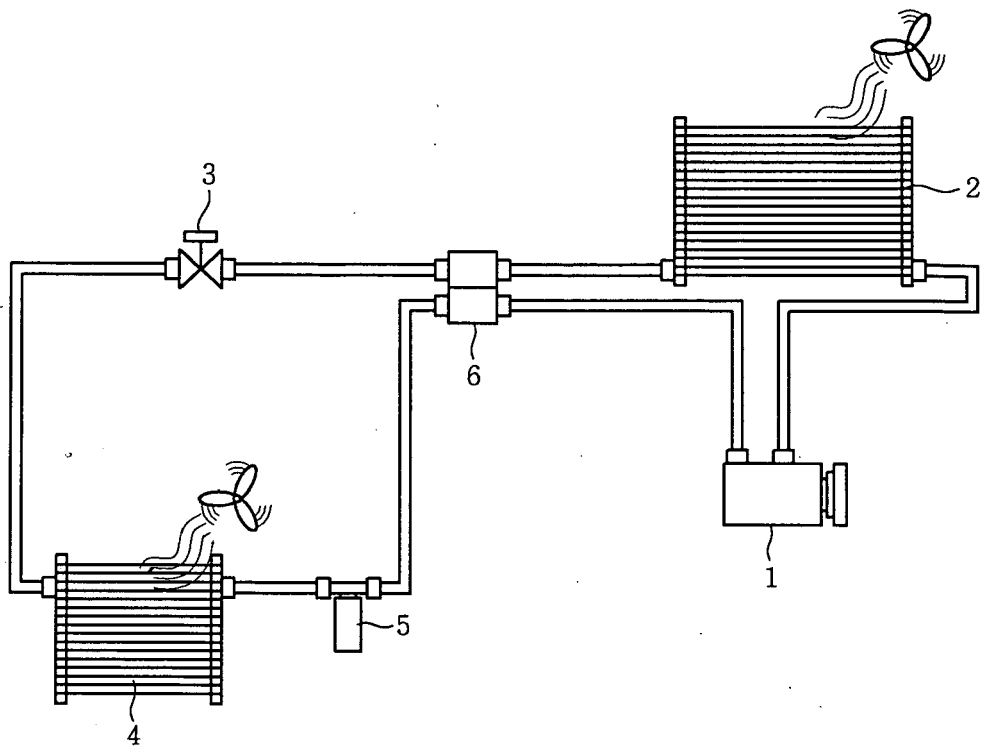
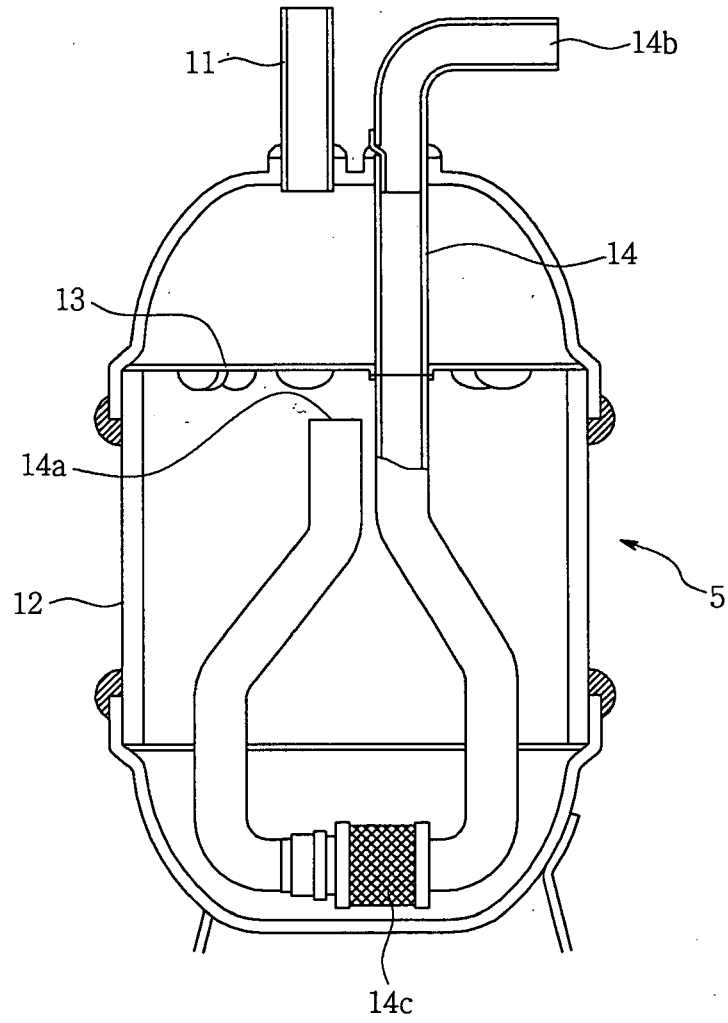

FIG. 2



Prior Art

FIG. 3

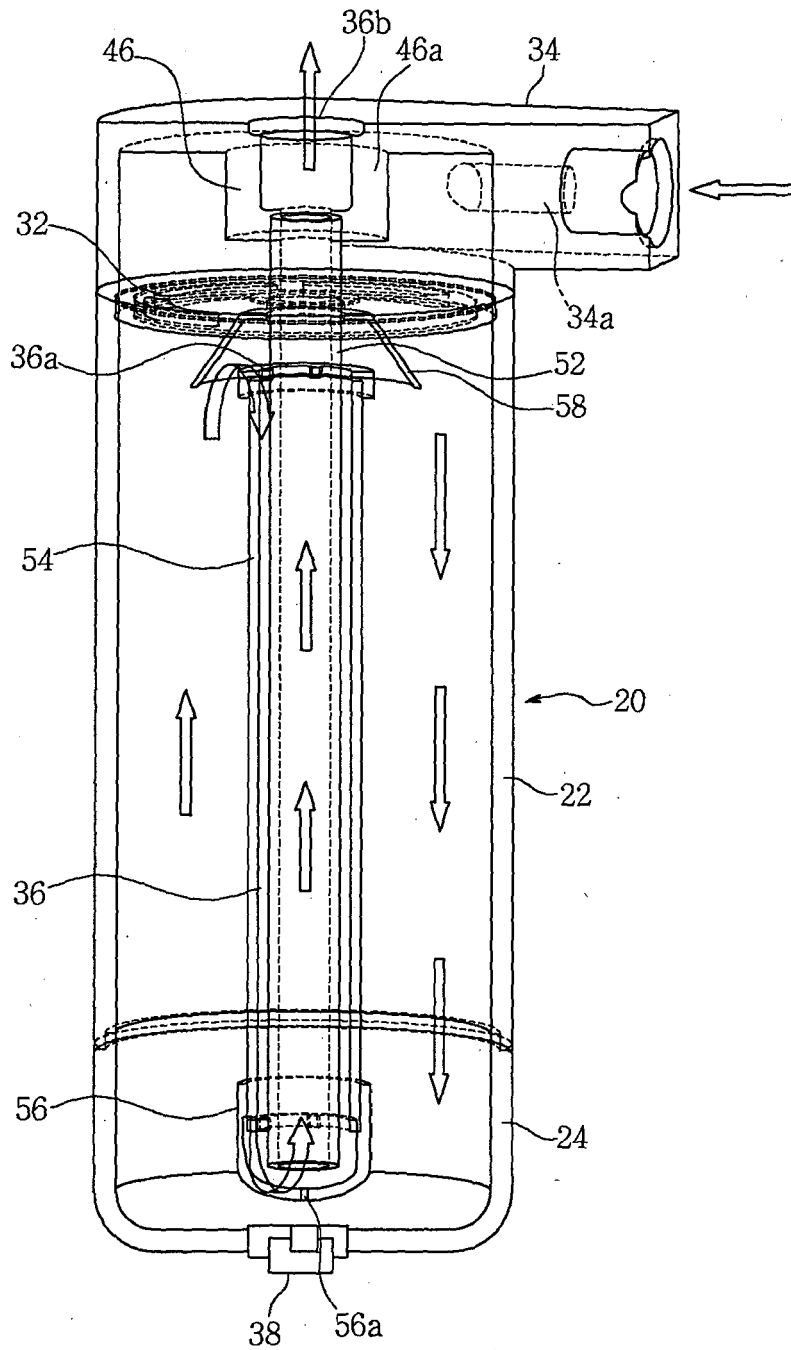

FIG. 4

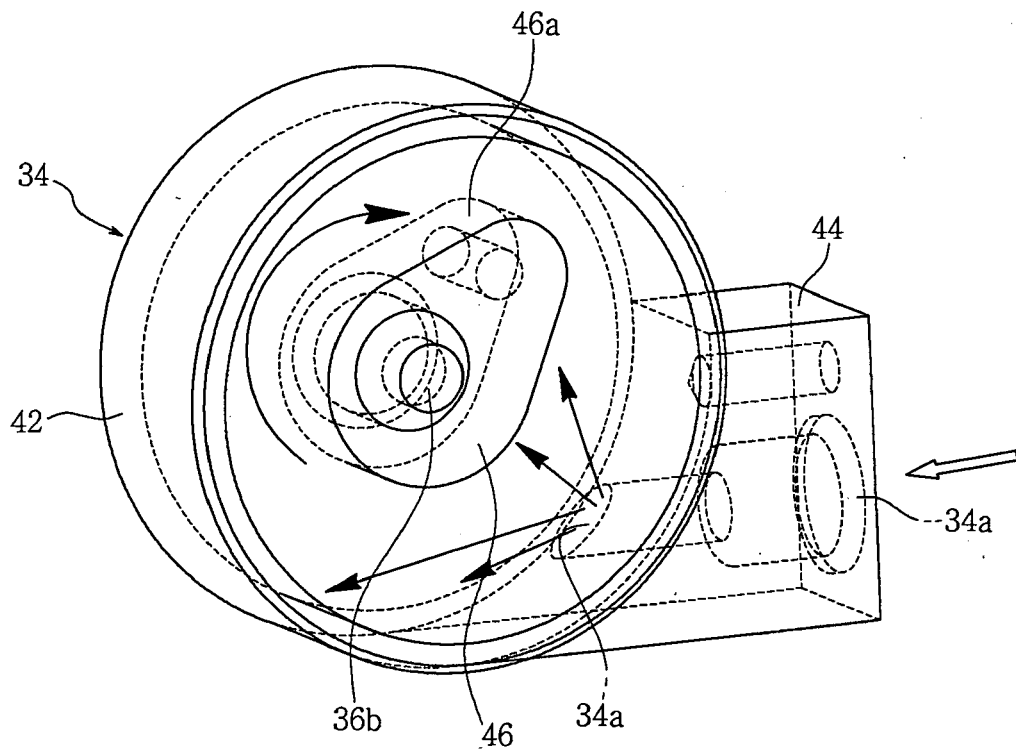

FIG. 5.

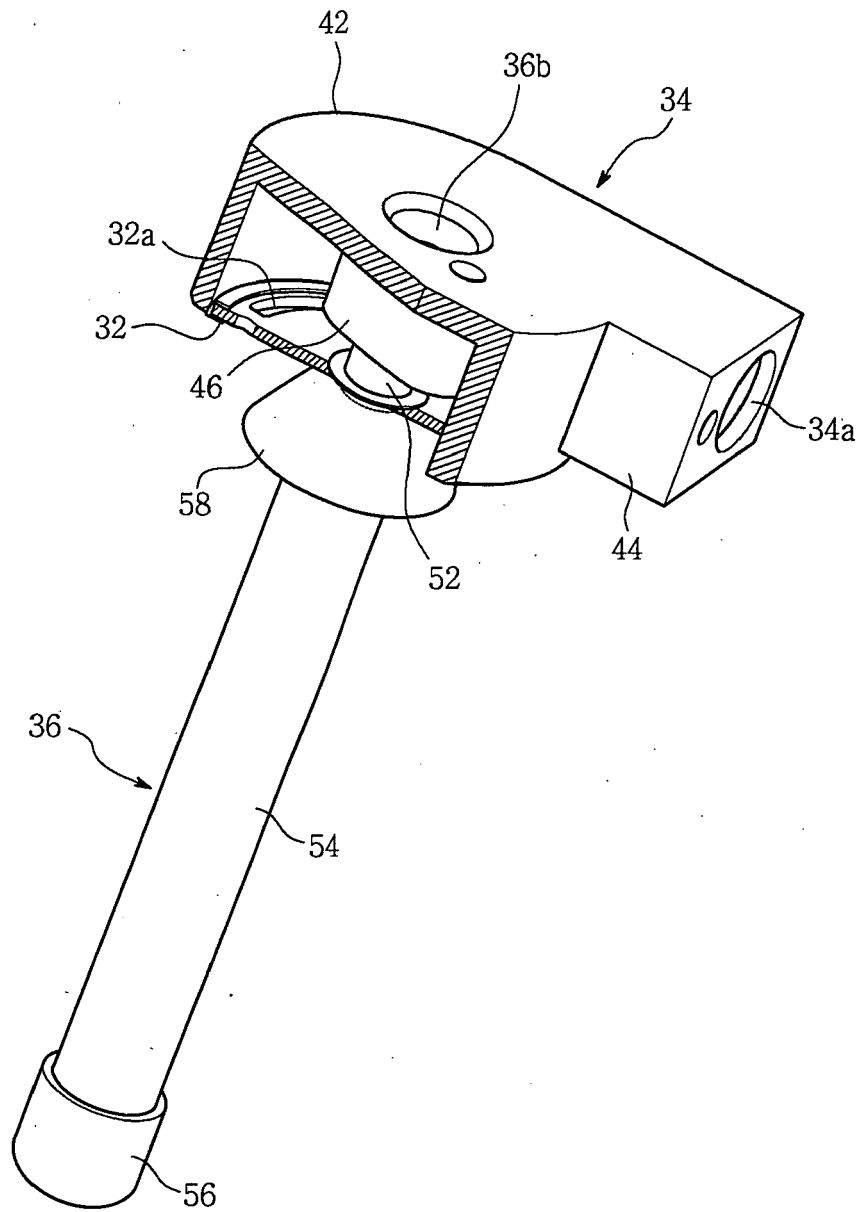

FIG. 6

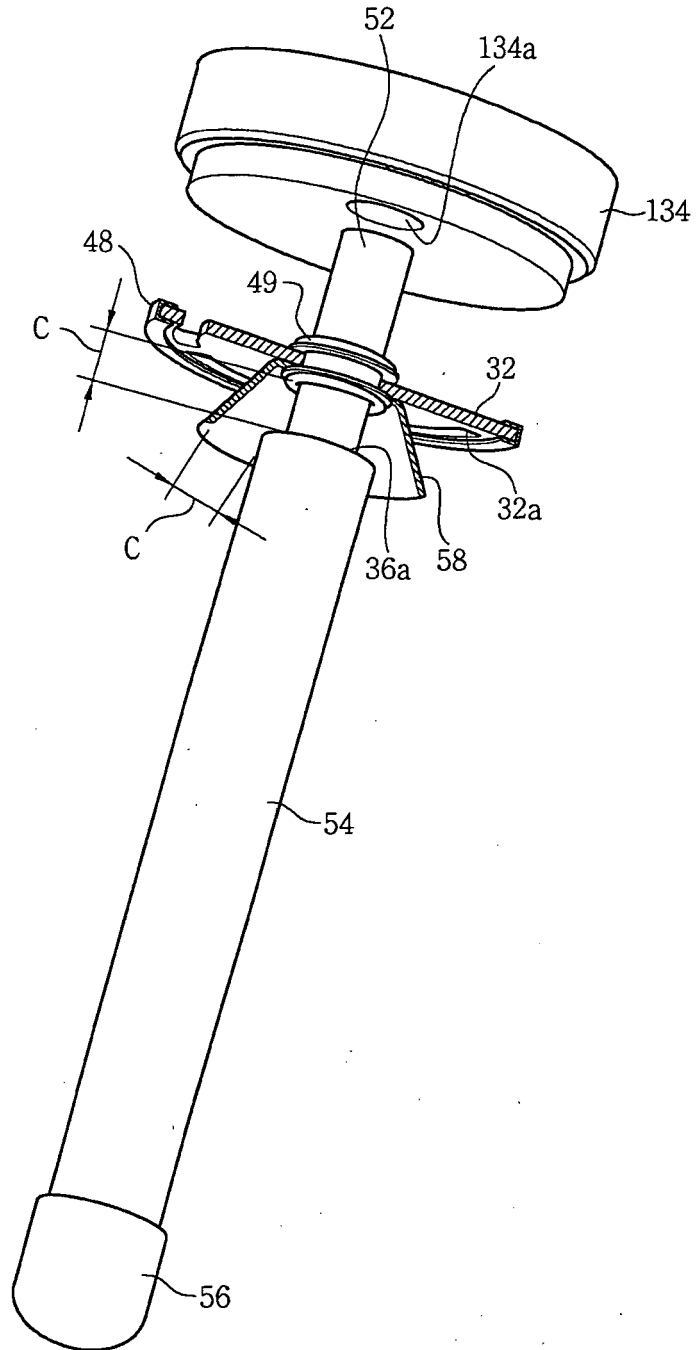

FIG. 7

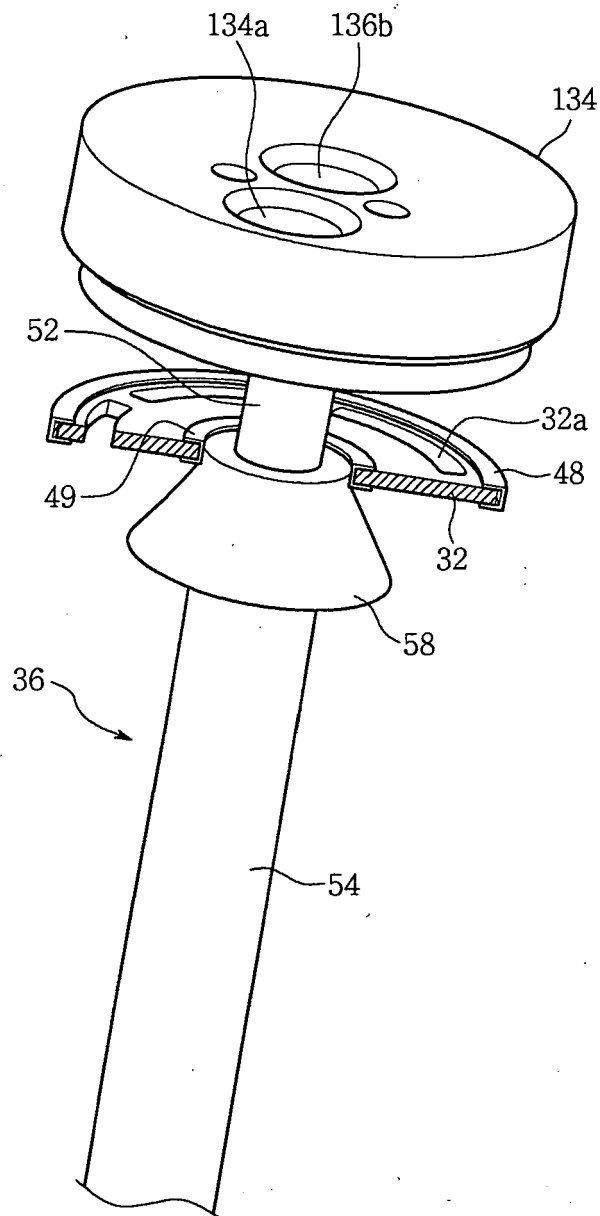

FIG. 8

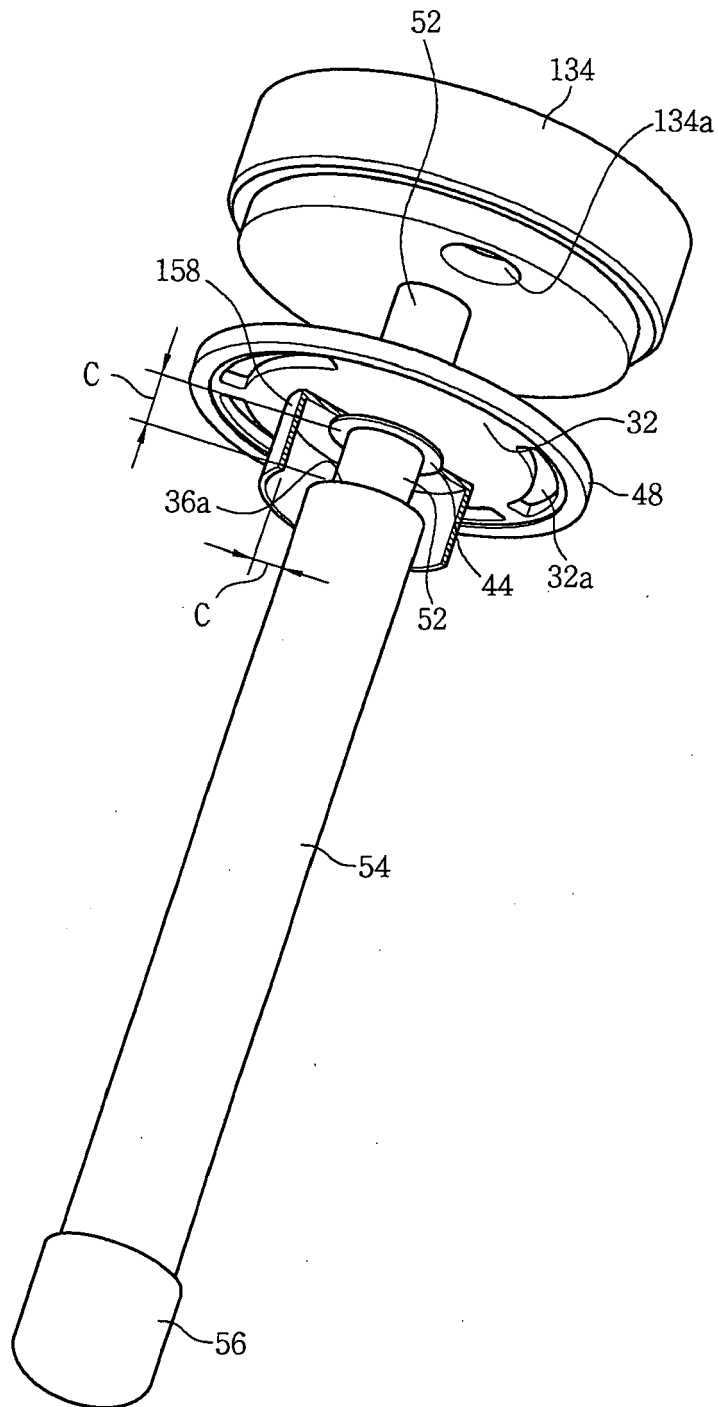

FIG. 9

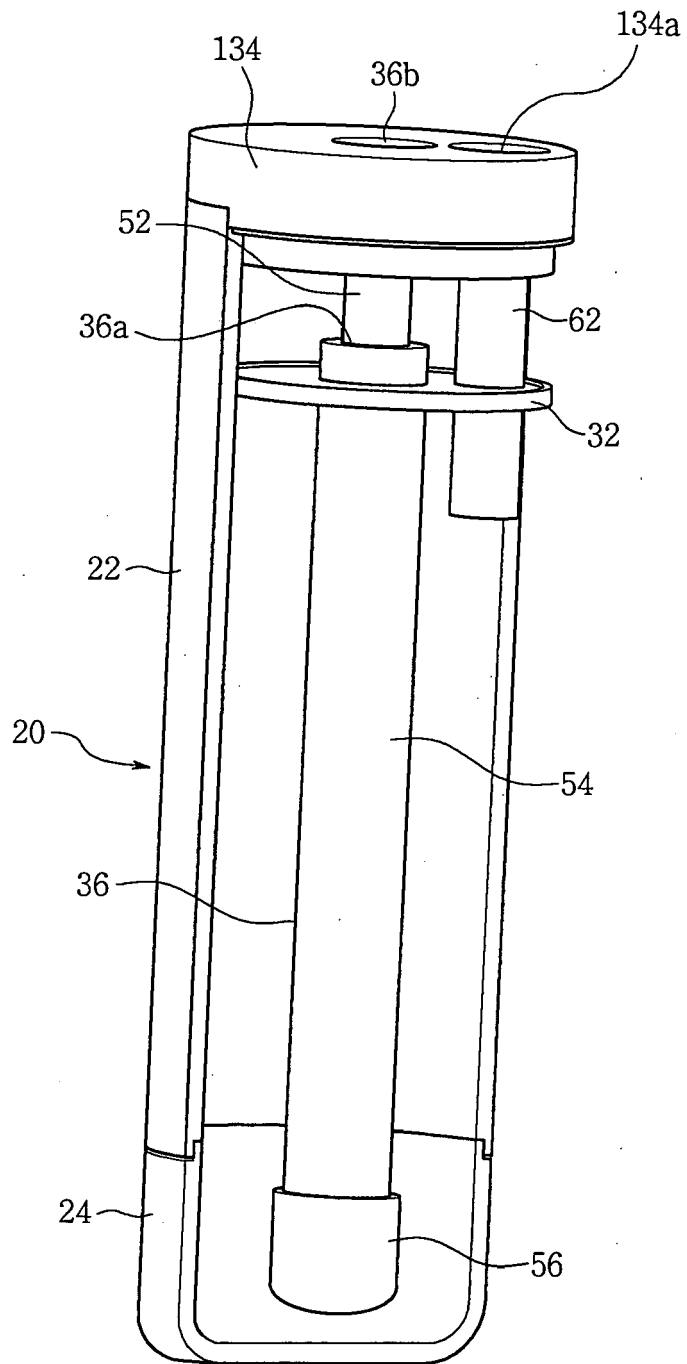

FIG. 10

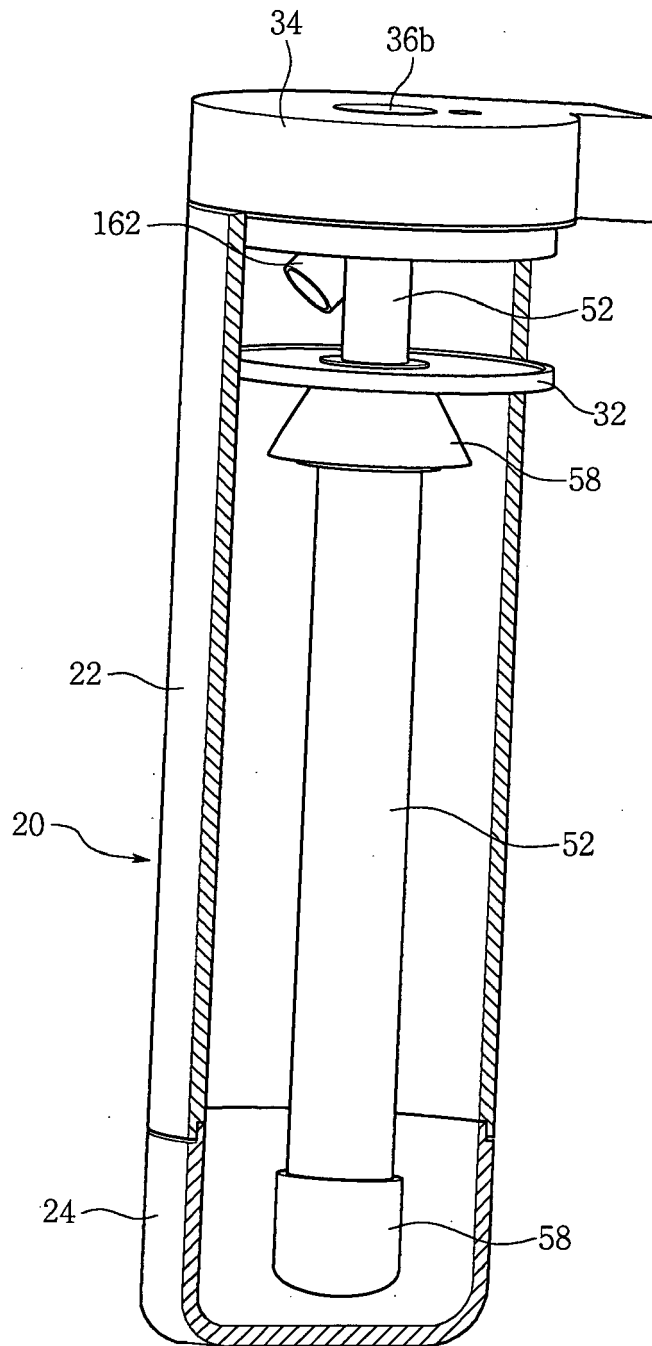

FIG. 11

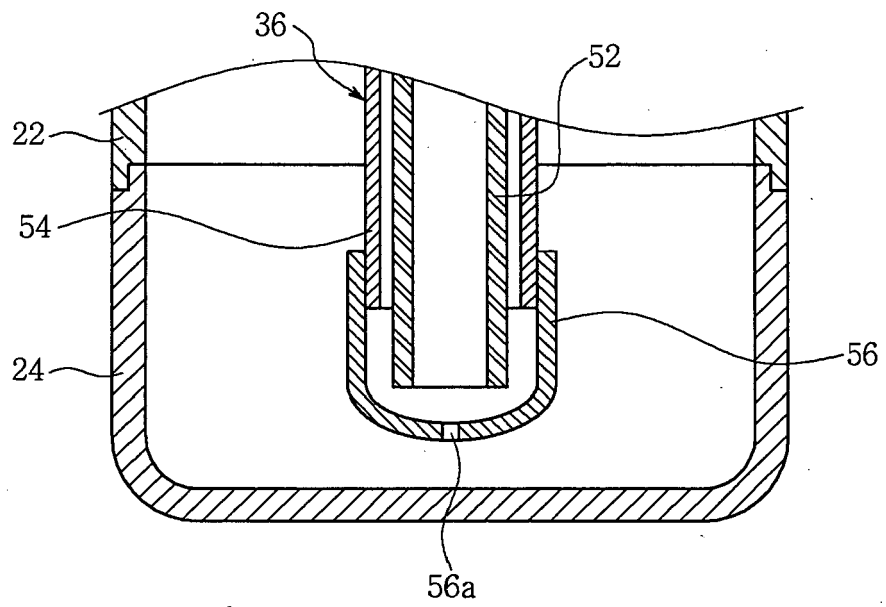

FIG. 12

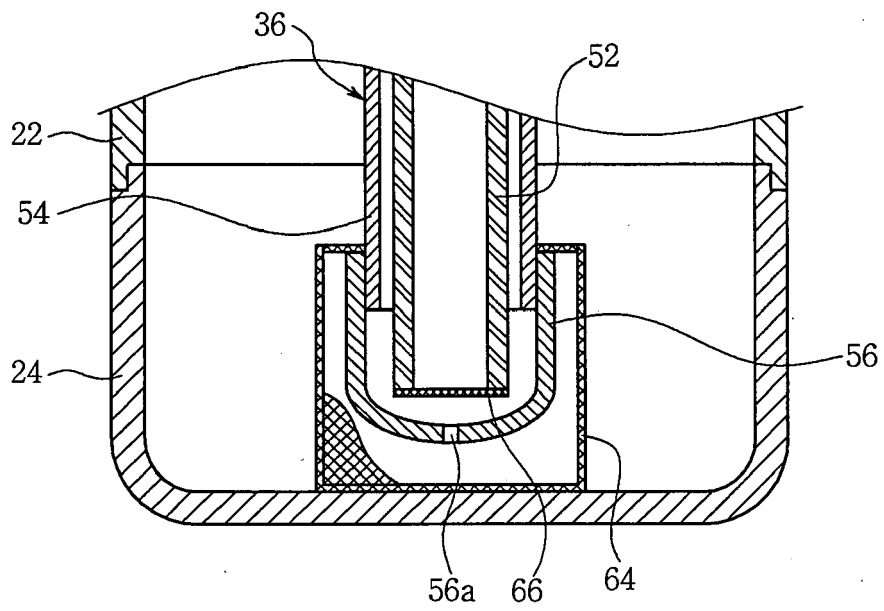

FIG. 13

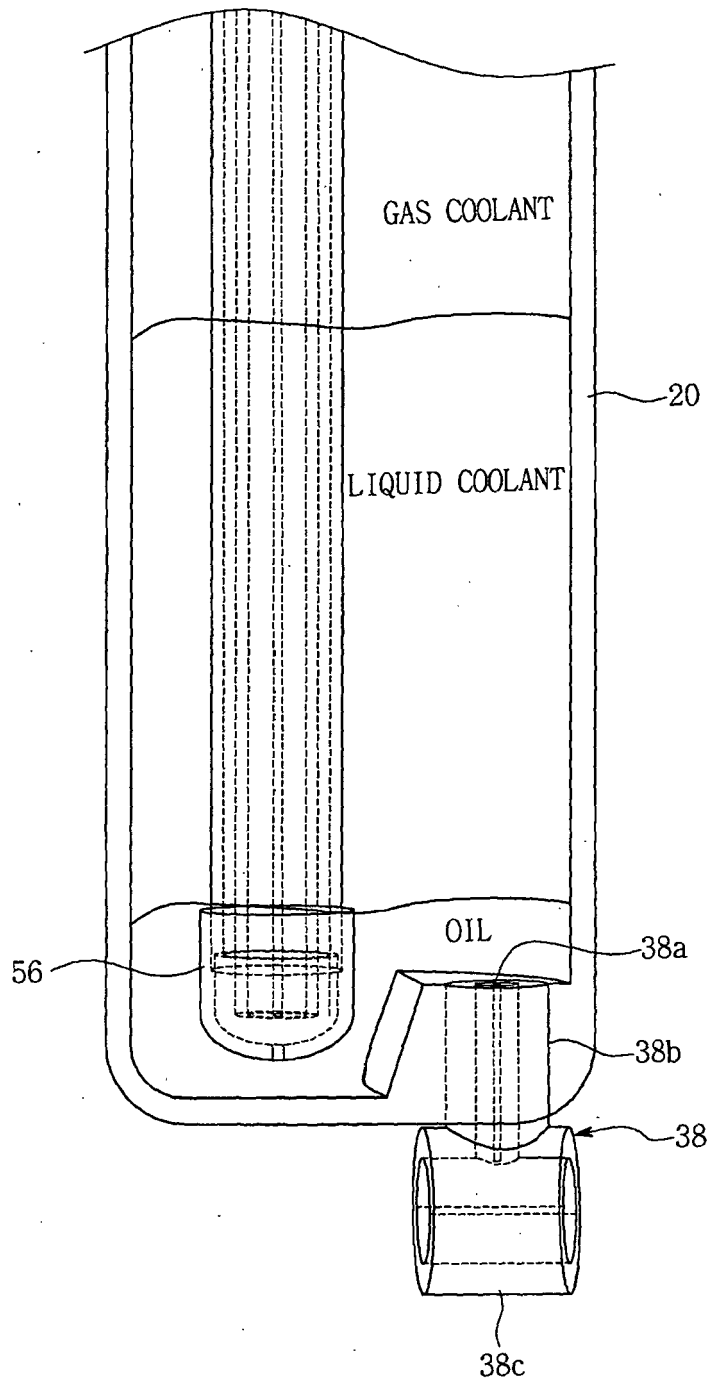

FIG. 14

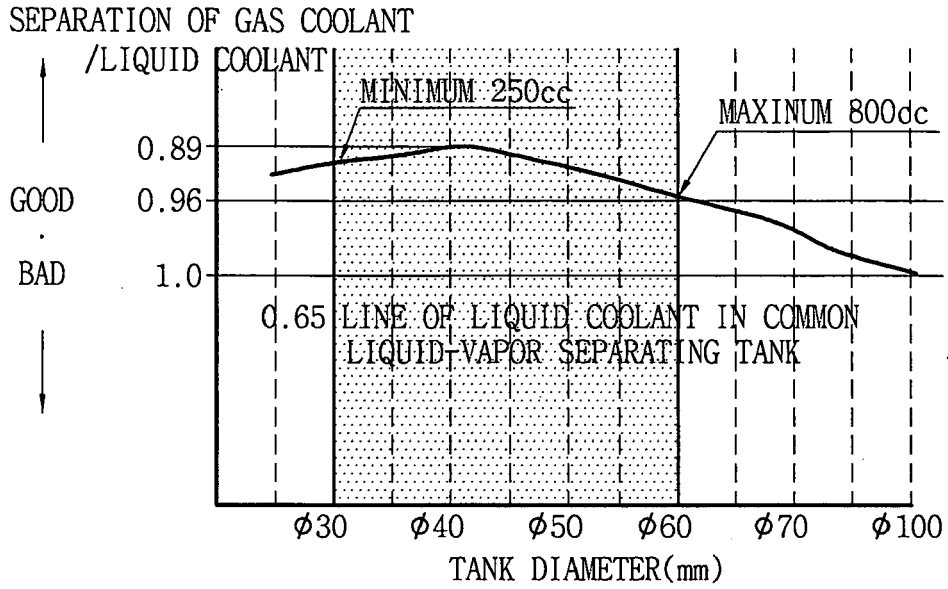

FIG. 15

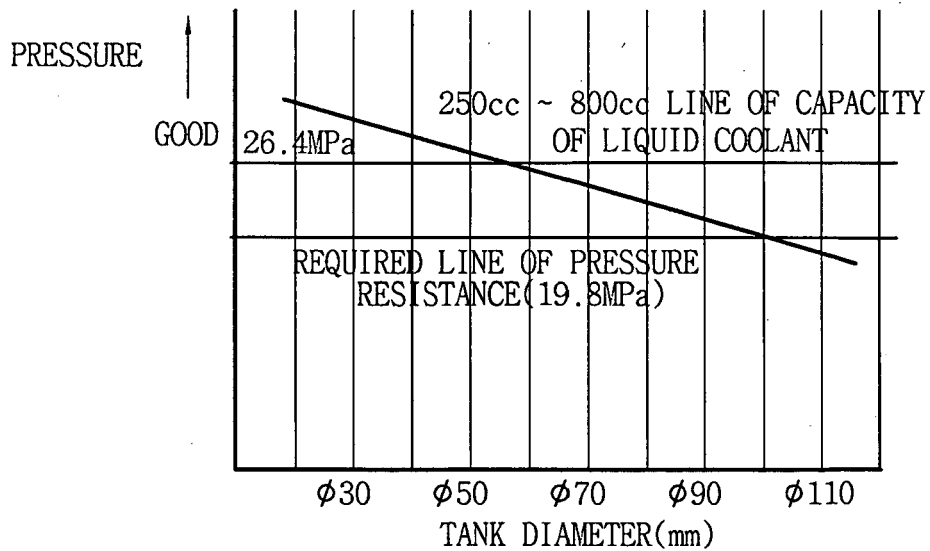

FIG. 16

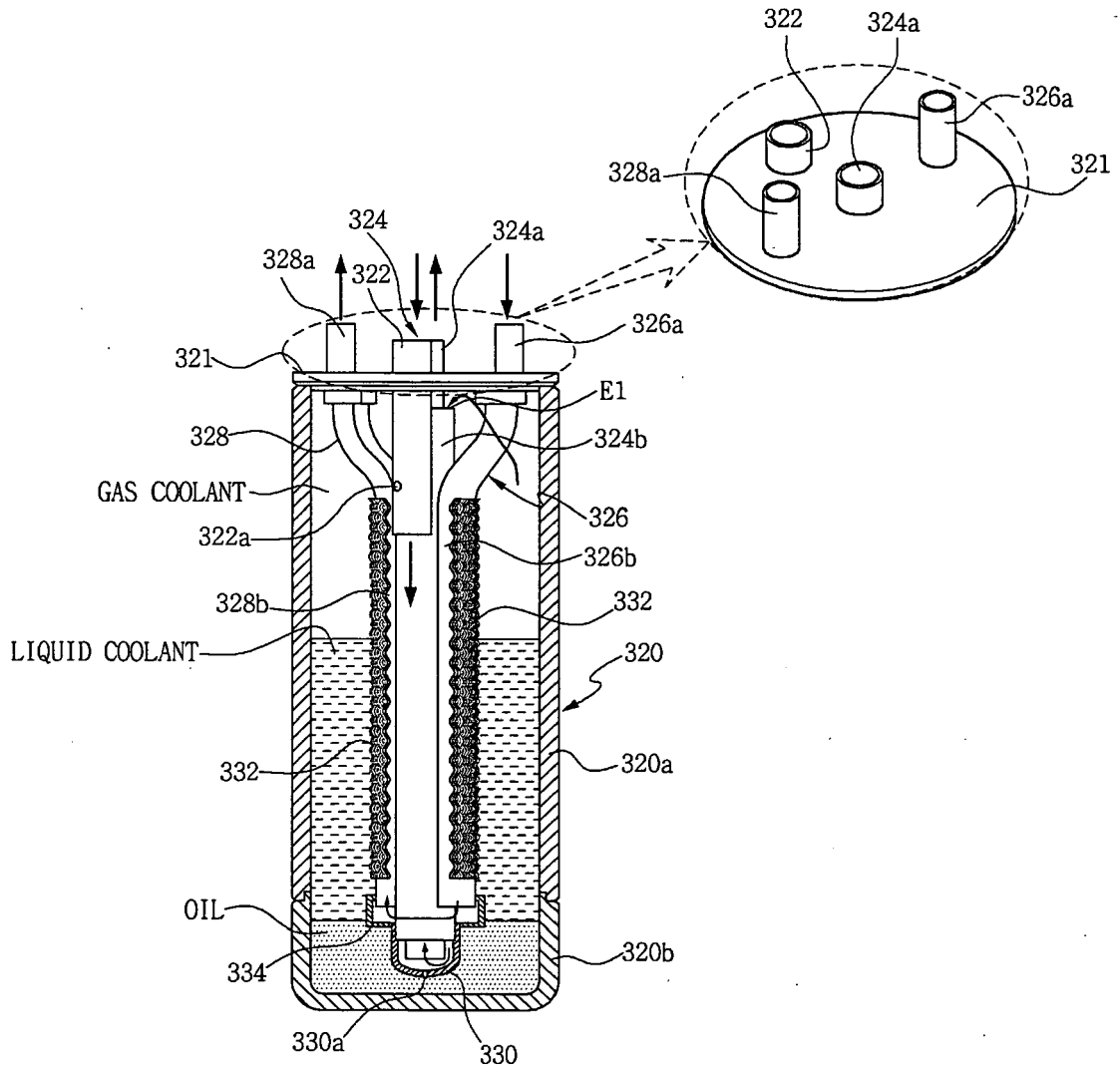

FIG. 17

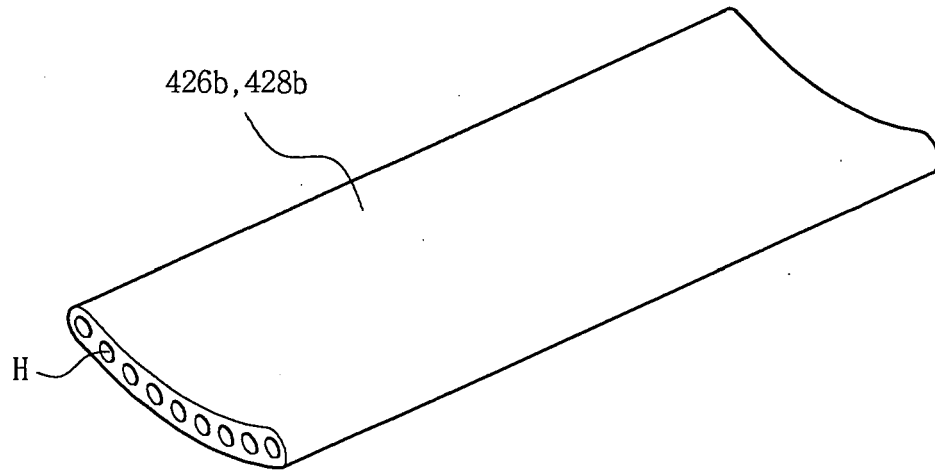

FIG. 18

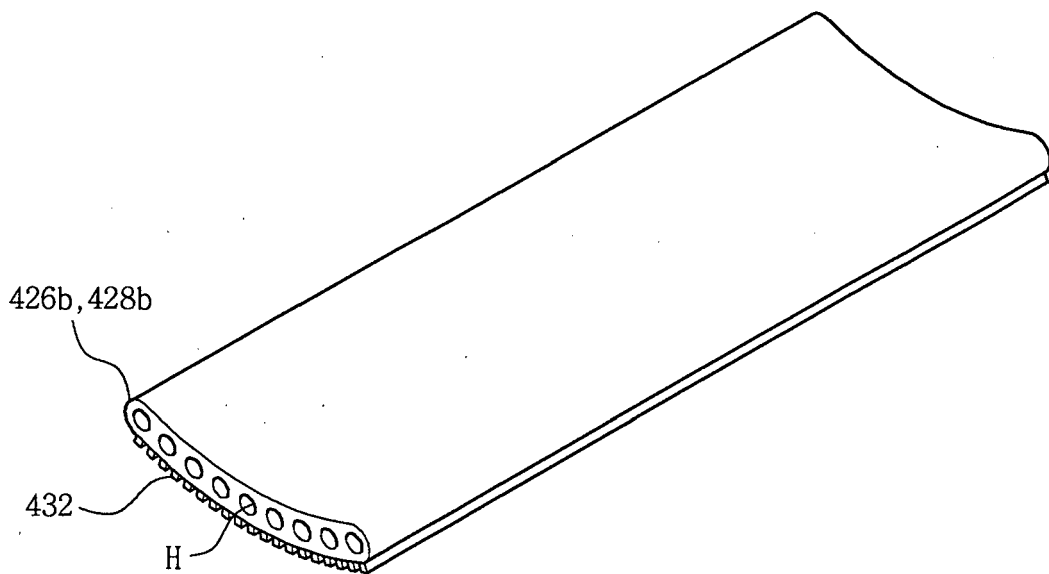

FIG. 19

