

(12) PATENT
(19) AUSTRALIAN PATENT OFFICE

(11) Application No. AU 199955916 B2
(10) Patent No. 763748

(54) Title
Bearing maintenance accessory

(51)⁶ International Patent Classification(s)
F16C 033/72 F16C 033/74
F16C 033/46 F16C 035/00

(21) Application No: 199955916

(22) Application Date: 1999.08.11

(87) WIPO No: W000/09896

(30) Priority Data

(31) Number	(32) Date	(33) Country
98/4816	1998.08.11	ZA

(43) Publication Date : 2000.03.06

(43) Publication Journal Date : 2000.05.04

(44) Accepted Journal Date : 2003.07.31

(71) Applicant(s)
David Hercules Slabbert

(72) Inventor(s)
David Hercules Slabbert

(74) Agent/Attorney
GRIFFITH HACK,GPO Box 4164,SYDNEY NSW 2001

(56) Related Art
US 2959457
US 5271676

55916/99



PCT

WORLD INTELLECTUAL PROPERTY ORGANIZATION
International Bureau

INTERNATIONAL APPLICATION PUBLISHED UNDER THE PATENT COOPERATION TREATY (PCT)

<p>(51) International Patent Classification 7 : F16C</p>	<p>A2</p>	<p>(11) International Publication Number: WO 00/09896 (43) International Publication Date: 24 February 2000 (24.02.00)</p>
<p>(21) International Application Number: PCT/ZA99/00064 (22) International Filing Date: 11 August 1999 (11.08.99) (30) Priority Data: 98/4816 11 August 1998 (11.08.98) ZA (71)(72) Applicant and Inventor: SLABBERT, David, Hercules [ZA/ZA]; 486 Missouri Street, Faerie Glen, Ext 1, Pretoria, 0043 (ZA). (74) Agent: JOHN & KERNICK; P.O. Box 3511, Halfway House 1685 (ZA).</p>		<p>(81) Designated States: AE, AL, AM, AT, AU, AZ, BA, BB, BG, BR, BY, CA, CH, CN, CU, CZ, DE, DK, EE, ES, FI, GB, GD, GE, GH, GM, HR, HU, ID, IL, IN, IS, JP, KE, KG, KP, KR, KZ, LC, LK, LR, LS, LT, LU, LV, MD, MG, MK, MN, MW, MX, NO, NZ, PL, PT, RO, RU, SD, SE, SG, SI, SK, SL, TJ, TM, TR, TT, UA, UG, US, UZ, VN, YU, ZA, ZW, ARIPO patent (GH, GM, KE, LS, MW, SD, SL, SZ, UG, ZW), Eurasian patent (AM, AZ, BY, KG, KZ, MD, RU, TJ, TM), European patent (AT, BE, CH, CY, DE, DK, ES, FI, FR, GB, GR, IE, IT, LU, MC, NL, PT, SE), OAPI patent (BF, BJ, CF, CG, CI, CM, GA, GN, GW, ML, MR, NE, SN, TD, TG).</p> <p>Published <i>Without international search report and to be republished upon receipt of that report.</i></p>

(54) Title: BEARING MAINTENANCE ACCESSORY

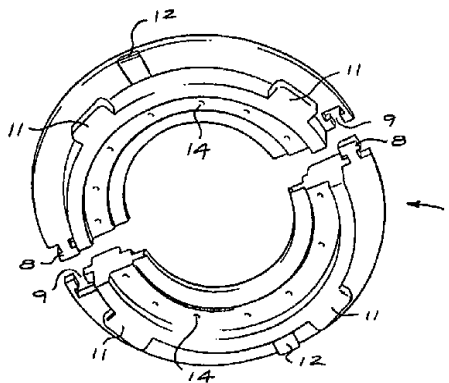

(57) Abstract

This invention relates to an accessory for maintaining bearings, more particularly but not exclusively, to an accessory for use in the cleaning of bearings. The bearings maintenance accessory is used for the maintenance and cleaning of a bearing located on a shaft within a bearing housing. The accessory consists of an annular manifold split into at least two parts. Each of the two parts has interlocking formations for releasably interlocking the parts together about a shaft. The manifold has an inlet in flow communication with an outlet through a flow passage for forcing a fluid through the manifold. A side of the manifold having the outlet is engageable against a face of a bearing housing.

- 1 -

BEARING MAINTENANCE ACCESSORY**FIELD OF THE INVENTION**

This invention relates to an accessory for maintaining bearings, more particularly, but not exclusively, to an accessory for use in the cleaning of bearings.

BACKGROUND TO THE INVENTION

5 Shafts which are rotatably secured in housings are, in most cases, supported on bearings located in the housing. These bearings are generally lubricated with a high temperature resistant grease. As bearings are normally sensitive to dirt and moisture, seals are secured in the housing over the shafts to protect the bearings.

10 Seals that are commonly used have varying degrees of success in preventing the ingress of dirt. Also, the bearings themselves can wear giving off particles of metal which are trapped in the grease. It is thus desirable to clean the bearings at suitable intervals and the most common method of doing this is by dismantling

part of the housing to expose the bearings which can then be cleaned with a solvent or other suitable fluid. This method of cleaning bearings is not only time consuming and costly in that machinery has to be stopped, and the housing dismantled, but also is not very effective as only parts of the bearings are usually exposed.

5

Another method includes the use of a annular plate which is used to replace the seal covers and has ports therein which allow a cleaning fluid to be projected therethrough onto the bearings. While fairly effective, use of such accessories is also problematical in that the shaft and housing have to be partially dismantled to allow the seals to be removed and the plate to be slid over the end of the bearing into engagement with the housing whereafter cleaning can commence.

10

SUMMARY OF THE INVENTION

15

In at least a preferred embodiment, the present invention preferably provides a maintenance accessory for bearings which will at least partially alleviate some of the abovementioned problems.

20

According to this invention there is provided a bearing maintenance accessory for cleaning a grease lubricated bearing located on a shaft and within a bearing housing, the accessory comprising:



an annular manifold radially split into two substantially equal parts having releasably interlocking formations for interlocking the parts together about the shaft adjacent the housing, with a side of the manifold releasably engageable against a face of the housing by lugs extending from the manifold and engageable with the housing; and each part of the manifold having an inlet for cleaning fluid in flow communication with a plurality of outlet nozzles on the side of the manifold adapted to be against the face of the housing and adapted to direct the cleaning fluid into the bearing.

25

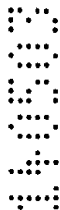

Preferably, the manifold includes at least one resilient clip preferably engagable in a notch in the face of the housing.

5 The invention also preferably provides for an inner periphery of the manifold to be grooved to form sealing ribs which engage on the shaft.

10 The invention extends to a method of cleaning a set of bearings within a bearing housing comprising the steps of interlocking two parts of an annular manifold about a shaft, engaging the interlocked parts with bearing housing to hold the side of the manifold having an outlet against a face of the housing, and forcing a fluid into an inlet of the manifold and out of the outlet into a set of bearings inside the housing.

15 These and other features of this invention will become apparent from the following description of one example illustrated in the accompanying drawings.

BRIEF DESCRIPTION OF THE DRAWINGS

A preferred embodiment of the invention is described below by way of example only and with reference to the accompanying drawings in which:

- 20 FIG. 1 is a perspective view of a first side bearing maintenance accessory;
FIG. 2 is a perspective view of the accessory in Figure 1 in use on a shaft and engaged with a pedestal bearing housing; and
FIG. 3 is a perspective view of a solvent gun;
25 FIG. 4 is a perspective view of an outlet side of a bearing maintenance accessory; and
FIG. 5 shows a seal assembly engaged on a face of a bearing housing with which the bearing maintenance accessory can be conveniently used.

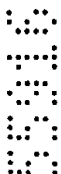

- 4 -

DETAILED DESCRIPTION OF THE DRAWINGS

A bearing maintenance accessory (1) is shown in Figures 1 and 2 and is an annular manifold which is radially split to form two equal parts (2). The accessory (1) is shaped to be a sliding fit over a shaft (3) to locate snugly against a pedestal bearing housing (4) about the shaft (3).

5 Each part (2) of the manifold has an inlet (5) which is in flow communication through a number of flow passages (not shown) within the thickness of the manifold, with a series of longitudinally directed nozzle (not shown). The nozzles form outlets on a first side of the manifold.

10 The inner periphery (6) of each part is grooved as indicated at (7) so that a pair of narrow ribs are provided which contact the shaft (3) and form a reasonable seal therewith during cleaning of a bearing.

15 Each manifold part (2) has interlocking formations which include a shaped tongue (8) at one end and a complementary shaped groove (9) at the other end. The tongue (8) and groove (9) are shaped for sliding engagement with the appropriate engagement formation on the other manifold part. In this way the two parts can be placed around opposite sides of the shaft and be interlocked by relative longitudinal movement on the shaft. The connected parts can then be moved in unison along the shaft.

20 Projections (10) extend from the manifold parts (2) at each end on the inlet side which overlap when the parts are interlocked and these projections facilitate manipulation of the accessory (1) into and out of its operative position.

25 Bearing housing engagement formations to retain the manifold in its operative position include stepped lugs (11). The lugs (11) are stepped to be spaced from the first side of the manifold. The lugs (11) are shaped to enter into openings (not shown) in the end of the housing (4) and on rotation of the accessory (1) the lugs will engage in slots in the housing extending circumferentially from the openings and so hold the first side of the manifold against the face of the housing. The lugs (11) and slots thus form a bayonet-type fitting. Alternatively,

- 5 -

the lugs may be inserted through openings in the housing and engage the inner face of a flange provided on the housing upon turning of the manifold.

5 To retain the manifold in an operative position, the engagement formations include at least one resilient clip (12) which projects from the periphery of the first side of the manifold between the lugs (11). The clip (12) engages in a notch (13) provided therefore in the bearing housing when the lugs (11) are operatively engaged in the housing.

10 In use, bearing seal assemblies such as those shown in figure 4 used for the bearings on the shaft (3) are removed from both ends of the housing (4). These seals are similarly engaged with the housing as described above for the manifold. The accessory (1) is split and each half (2) placed over the shaft (3). The halves (2) are then secured together by sliding the interlocking tongues (7) and grooves (8) into engagement. Hereafter the accessory (1) is slid along the shaft and operatively engaged with the housing as above described.

15 A cleaning solvent is then forced through the outlet onto the bearings (not shown). As shown in Figure 3, a solvent gun (30) is provided for this purpose. The gun (30) has a pair of outlets (31) which respectively locate in the inlet openings (5) and communicate with a solvent filled reservoir (32). Compressed air is fed via a hose (33) into the reservoir (32) to force the solvent through the
20 outlets (31). Flow of compressed air is conveniently controlled through a trigger mechanism (34).

25 The solvent is thus forced through the inlets (5) and respective flow passages and through outlets (not shown) in an even manner onto the bearings (not shown). The solvent is allowed to flow out of the housing through the opening left by the removal of the seal at the opposite end of the bearing housing to which the maintenance accessory is secured.

30 When cleaning is complete, the bearings can be lubricated through the openings using an appropriate grease gun. Alternatively, the accessory can be removed and grease applied in conventional fashion. Removal of the accessory is accomplished by releasing the resilient tongues (10) out of engagement with the

- 6 -

notches (11) (conveniently by means of a screw driver) and then reversing the fitting procedure described above.

5 A cost and time effective method of cleaning bearings is thus provided which has the added advantage that rotation of the shaft need not be stopped to perform cleaning as the top of the pedestal housing does not have to be removed during the maintenance procedure.

10 It will be appreciated however, that many other embodiments of a cleaning accessory exist which fall within the scope of the invention especially as regards the configuration thereof. For example, the accessory need not be attached to the housing in the manner described but could be secured thereto by mechanical fasteners or even by providing a screw threaded connection. Any suitable number of outlets can be provided and these could simply be longitudinally extending holes drilled into the accessory. Clearly, the shape of the accessory will differ to fit the particular configuration of shaft and housing.

THE CLAIMS DEFINING THE INVENTION ARE AS FOLLOWS:

1. A bearing maintenance accessory for cleaning a grease lubricated bearing located on a shaft and within a bearing housing, the accessory comprising:
an annular manifold radially split into two substantially equal parts having
releasably interlocking formations for interlocking the parts together about the
shaft adjacent the housing, with a side of the manifold releasably engageable
against a face of the housing by lugs extending from the manifold and
engageable with the housing; and
each part of the manifold having an inlet for cleaning fluid in flow communication
with a plurality of outlet nozzles on the side of the manifold adapted to be against
the face of the housing and adapted to direct the cleaning fluid into the bearing.
2. A bearing maintenance accessory as claimed in claim 1 in which the manifold
includes at least one resilient clip releasably engageable in a notch in the face of
the housing.
3. A bearing maintenance accessory as claimed in claim 1 or claim 2 in which an
inner periphery of the manifold is grooved to form sealing ribs which engage on
the shaft.
4. A method of cleaning bearings within a bearing housing comprising the steps of
interlocking two parts of an annular manifold about a shaft, engaging the
interlocked parts with a bearing housing to hold the side of the manifold having an
outlet against a face of the housing, and forcing a cleaning fluid into an inlet for
the manifold and out through a plurality of outlet nozzles for the manifold into a
bearing located in the housing.
5. A bearing maintenance accessory as substantially described herein with reference
to the accompanying drawings.

Dated this 12th day of May
David Hercules Slabbert
By their Patent Attorneys
GRIFFITH HACK

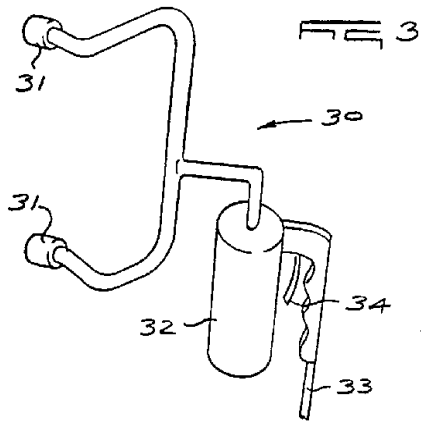
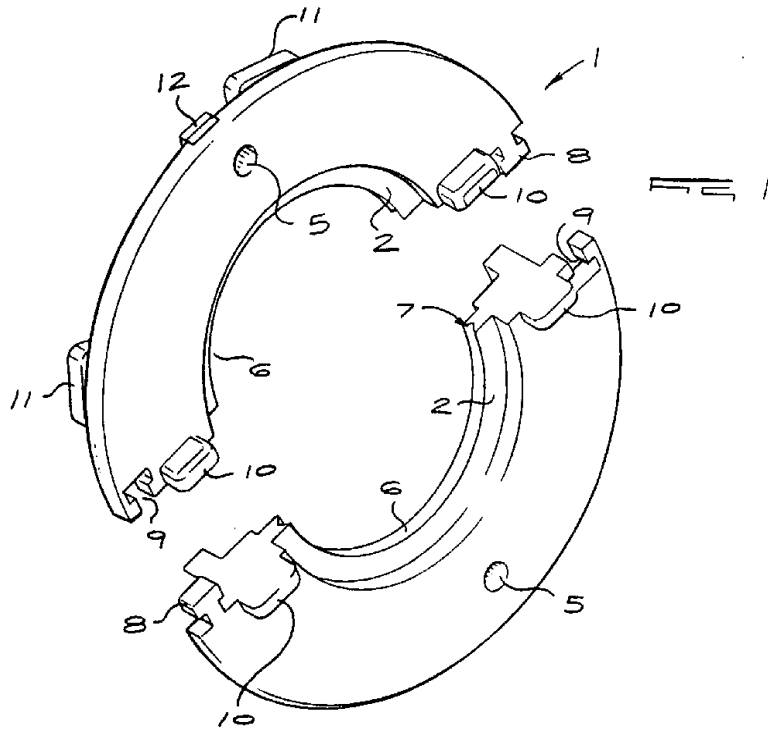

2/3

