

(19) World Intellectual Property Organization
International Bureau



(43) International Publication Date
15 April 2004 (15.04.2004)

PCT

(10) International Publication Number
WO 2004/031802 A1

- (51) International Patent Classification⁷: G01S 15/89, 7/52, G10K 11/34
- (21) International Application Number: PCT/IB2003/003999
- (22) International Filing Date: 1 September 2003 (01.09.2003)
- (25) Filing Language: English
- (26) Publication Language: English
- (30) Priority Data: 10/264,900 4 October 2002 (04.10.2002) US
- (71) Applicant: KONINKLIJKE PHILIPS ELECTRONICS N.V. [NL/NL]; Groenewoudseweg 1, NL-5621 BA Eindhoven (NL).
- (71) Applicant (for AE only): U.S. PHILIPS CORPORATION [US/US]; 1251 Avenue of the Americas, New York, NY 10020 (US).
- (72) Inventors: POLAND, McKee, Dunn; P.O. Box 3001, Briarcliff Manor, NY 10510-8001 (US). SAVORD, Bernard, J.; P.O. Box 3001, Briarcliff Manor, NY 10510-8001 (US). ANTHONY, Michael, P.; P.O. Box 3001, Briarcliff Manor, NY 10510-8001 (US).
- (74) Common Representative: KONINKLIJKE PHILIPS ELECTRONICS N.V.; c/o VODOPIA, John, P.O. Box 3001, Briarcliff Manor, NY 10510-8001 (US).
- (81) Designated States (national): AE, AG, AL, AM, AT, AU, AZ, BA, BB, BG, BR, BY, BZ, CA, CH, CN, CO, CR, CU, CZ, DE, DK, DM, DZ, EC, EE, ES, FI, GB, GD, GE, GH, GM, HR, HU, ID, IL, IN, IS, JP, KE, KG, KP, KR, KZ, LC, LK, LR, LS, LT, LU, LV, MA, MD, MG, MK, MN, MW, MX, MZ, NI, NO, NZ, OM, PG, PH, PL, PT, RO, RU, SC, SD, SE, SG, SK, SL, SY, TJ, TM, TN, TR, TT, TZ, UA, UG, UZ, VC, VN, YU, ZA, ZM, ZW.
- (84) Designated States (regional): ARIPO patent (GH, GM, KE, LS, MW, MZ, SD, SL, SZ, TZ, UG, ZM, ZW).

[Continued on next page]

(54) Title: METHOD AND APPARATUS FOR 1D ARRAY ULTRASOUND PROBE

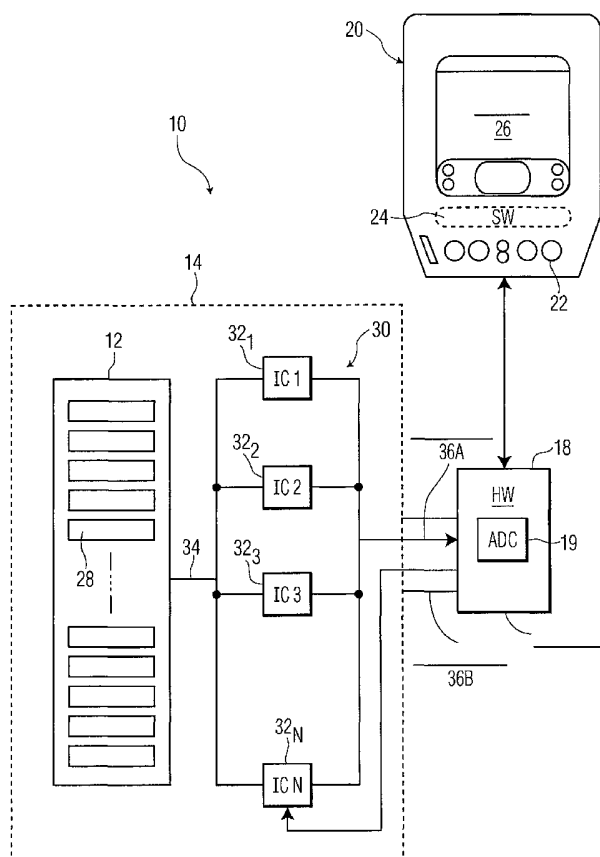

(57) Abstract: A phased array ultrasound scanning apparatus includes a one-dimensional (1-D) array of ultrasound transducer elements having transmit and receive elements. The 1-D array is responsive to a transmitter configured to energize the transmit elements for generating a transmit acoustic beam directed into a region of interest. A receive beamformer, operatively connected to the 1-D array, synthesizes receive beams, in response to echoes of the transmit acoustic beam received from the region of interest. The receive beamformer includes analog random access memory (ARAM) delay elements configured to delay signals received from the receive elements and provide the delayed signals on an output of the receive beamformer as a beamformed RF output. The beamformed RF output is suitable for use in forming an image of the region of interest.

WO 2004/031802 A1



Eurasian patent (AM, AZ, BY, KG, KZ, MD, RU, TJ, TM),
European patent (AT, BE, BG, CH, CY, CZ, DE, DK, EE,
ES, FI, FR, GB, GR, HU, IE, IT, LU, MC, NL, PT, RO,
SE, SI, SK, TR), OAPI patent (BF, BJ, CF, CG, CI, CM,
GA, GN, GQ, GW, ML, MR, NE, SN, TD, TG).

TR, TT, TZ, UA, UG, UZ, VC, VN, YU, ZA, ZM, ZW, ARIPO
patent (GH, GM, KE, LS, MW, MZ, SD, SL, SZ, TZ, UG,
ZM, ZW), Eurasian patent (AM, AZ, BY, KG, KZ, MD, RU,
TJ, TM), European patent (AT, BE, BG, CH, CY, CZ, DE,
DK, EE, ES, FI, FR, GB, GR, HU, IE, IT, LU, MC, NL, PT,
RO, SE, SI, SK, TR), OAPI patent (BF, BJ, CF, CG, CI, CM,
GA, GN, GQ, GW, ML, MR, NE, SN, TD, TG)

Declaration under Rule 4.17:

— as to applicant's entitlement to apply for and be granted
a patent (Rule 4.17(ii)) for the following designations AE,
AG, AL, AM, AT, AU, AZ, BA, BB, BG, BR, BY, BZ, CA,
CH, CN, CO, CR, CU, CZ, DE, DK, DM, DZ, EC, EE, ES,
FI, GB, GD, GE, GH, GM, HR, HU, ID, IL, IN, IS, JP, KE,
KG, KP, KR, KZ, LC, LK, LR, LS, LT, LU, LV, MA, MD,
MG, MK, MN, MW, MX, MZ, NI, NO, NZ, OM, PG, PH,
PL, PT, RO, RU, SC, SD, SE, SG, SK, SL, SY, TJ, TM, TN,

Published:

— with international search report

For two-letter codes and other abbreviations, refer to the "Guidance Notes on Codes and Abbreviations" appearing at the beginning of each regular issue of the PCT Gazette.

METHOD AND APPARATUS FOR 1D ARRAY ULTRASOUND PROBE

The present disclosure relates to ultrasound imaging devices, and more particularly, to a method and apparatus for a 1-D array ultrasound probe.

5 Phased array ultrasonic imaging systems have been used to produce real-time images of internal portions of the human body. Such imaging systems include a multiple channel transmit beamformer and a multiple channel receive beamformer either coupled to a single array of ultrasonic transducers using a transmit/receive switch, or coupled separately to a transmit transducer array and a receive transducer array. The transmit beamformer generates timed electrical pulses and applies them to the individual transducer elements in a predetermined timing sequence. The transducers respond to the electrical pulses and emit corresponding pressure waves, which are phased to form a transmit beam that propagates in a predetermined direction from the transducer array.

10 As the transmit beam passes through the body, a portion of the acoustic energy is scattered back toward the transducer array from tissue structures having different acoustic characteristics. An array of receive transducers (which may be the same as the transmit array) converts the pressure pulses into the corresponding electrical pulses. Due to different distances, the ultrasonic energy scattered from a tissue structure, arrives back at the individual transducers at different times. Each transducer produces an electrical signal that is amplified and provided to one processing channel of the receive beamformer. The receive beamformer has a plurality of processing channels with compensating delay elements connected to a summing element. The system selects a delay value for each channel to collect echoes scattered from a selected point.

25 Consequently, when the delayed signals are summed, a strong signal is produced from signals corresponding to the selected point, but signals arriving from other points, corresponding to different times, have different phase relationships and thus destructively interfere. The relative delays of the compensating delay elements control the orientation of the receive beam with respect to the transducer array. By varying the delays during reception of echoes from a given transmit event, the receive beamformer can steer the receive beam to have a desired direction and can dynamically focus over a range of depths.

30 To collect imaging data, the transmit beamformer directs the transducer array to emit ultrasound beams along multiple transmit scan lines distributed over a desired scan pattern. For each transmit beam, the receive transducer array connected to the receive

beamformer synthesizes one or several receive beams having selected orientations. The transmit and receive beams form a round-trip beam (i.e., "center of mass" beam) that is generated over a predetermined angular spacing to create a wedge-shaped acoustic image or is generated over a predetermined linear spacing to create a parallelogram-shaped acoustic image. Arbitrary combinations of the aforementioned patterns can be used to create more complex scanned image shapes, with arbitrary density of acoustic sampling.

A one-dimensional array may have up to several hundred elements. These elements are typically connected to a system with 128 channels of processing electronics. The receive beamformer within these channels uses digital signal processing involving an A/D converter and digital circuitry. This circuitry takes a substantial amount of size and power such that a hand held system cannot be built using this method.

Generally, ultrasound imaging devices are large, expensive ultrasound devices that connect to probes which do not contain integrated high voltage pulsers, nor transmit/receive beamforming, and are not very portable.

Accordingly, it would be desirable to provide an ultrasound imaging system architecture that uses a large transducer array for providing two-dimensional images and that is practical in size, cost and complexity.

A phased array ultrasound scanning apparatus includes a one-dimensional (1-D) array of ultrasound transducer elements having transmit and receive elements. The 1-D array is responsive to a transmitter configured to energize the transmit elements for generating a transmit acoustic beam directed into a region of interest. A receive beamformer, operatively connected to the 1-D array, synthesizes receive beams, in response to echoes of the transmit acoustic beam received from the region of interest. The receive beamformer includes analog random access memory (ARAM) delay elements configured to delay signals received from the receive elements and provide the delayed signals on an output of the receive beamformer as a beamformed RF output. The beamformed RF output is suitable for use in forming an image of the region of interest.

FIG. 1 is a diagrammatic view of a phased array ultrasound imaging system according to one embodiment of the present disclosure;

FIG. 2 is a diagrammatic view of the imaging system including a 1-D array of ultrasound transducers operatively coupled to a transmit beamformer and a receive beamformer according to one embodiment of the present disclosure;

FIG. 3 is a block diagram view of several illustrative transducer elements operatively coupled to programmable delay lines connected to a summing junction of the receive beamformer; and

FIG. 4 is a diagrammatic view of an analog random access memory element used as a programmable delay element in the receive beamformer of the ultrasound imaging system of the present disclosure.

Referring to FIG. 1, a phased array ultrasonic imaging system 10 includes an array of transducer elements 12 located in a transducer handle 14. Transducer handle 14 operatively couples via a transducer cable 16 and a transducer interface 18 to an electronics unit 20. Interface 18 may include, for example, an analog to digital converter 19 (ADC) for converting analog signal to respective digital signals, as well as other circuitry. Electronics unit 20 includes a control panel 22, operating and application software 24, and provides imaging signals to display 26. Software 24 includes components for image detection and scan conversion. Image detection preferably includes the steps or RF filtering, mixing, analytic echo envelope detection, logging, and further smoothing. Scan conversion converts the echo data from the format of the scanned acoustic lines to the preferably Cartesian format of display 26.

Transducer array 12 can include several hundred transducer elements 28 arranged as a large one-dimensional array, phased array (PA), linear array (LA) or curved linear array (CLA) according to the requirements for a particular ultrasound imaging system. In addition, transducer array 12 may have the transducer elements arranged into separate transmit and receive arrays distributed along the one-dimensional array. Alternatively, the transducer transmit and receive elements may be distributed over a semi-random pattern along the one-dimensional array.

Transducer handle 14 includes transmit pulse generators and the associated high voltage drivers, low noise receive pre-amplifiers, and delay and summing circuits, generally indicated by reference numeral 30. Importantly, in one embodiment, the elements are integrated within a small volume and placed inside transducer handle 14.

Transducer cable 16 includes at least one signal wire, power supply wires, clock lines, and digital communication.

Alternatively, transducer array 12 employs the same transducer elements to emit a transmit beam and detect a receive beam. In this arrangement, imaging system 10 includes a transmit/receive switch (T/R switch not shown in FIG. 1) to switch between a transmit beamformer and a receive beamformer depending on the operating mode. During transmission of ultrasound energy, the switch connects the elements to the transmit beamformer and protect the receive beamformer. After emitting the transmit beam, the T/R switch connects the transducer elements to the receive beamformer.

In one embodiment, ultrasound imaging system 10 utilizes a one-dimensional transducer array 12 having, for example, 128 transducer elements to acquire two-dimensional image data of a human organ or region of interest. Imaging system 10 uses approximately one half of the transducer elements to transmit ultrasound energy and the other half to receive ultrasound energy. The transmit and receive elements are randomly distributed over array 12. By separating the transmit and receive elements, the system can be fabricated without the T/R switches, thus reducing a complexity of the system.

Each integrated circuit 32 may include a set of digital pulse generators that generate transmit pulses and high voltage driver circuits that amplify the transmit pulse to on the order of approximately one hundred volts (~100 v) used to excite the transducer element to emit ultrasound. Each integrated circuit may also include low noise receive preamplifiers, analog delay circuitry to perform the receive beamforming, and digital control circuitry, further as discussed below. The low noise receive preamplifiers preamplify the transducer signal and provide the preamplified signal to the delay circuitry. The delay circuitry performs receive beamforming by applying selected delay values to the signals.

FIG. 2 is a block diagram of imaging system 10 having transducer array 12 operatively coupled to a transmit beamformer 38 and operatively coupled to receive beamformer 40.

As described in connection with FIG. 3, the channels 44_i of receive beamformer 40 include programmable delay elements 46 connected to a summing element 48 (a summing junction). The programmable delay element 44_i of each respective channel of the receive beamformer 40 delays the corresponding individual transducer signals and connects to summing junction 48. The summing junction adds the delayed signals and provides the summed signal to the channel output 50 of receive beamformer 40.

Referring again to FIG. 2, a system controller 52 includes a microprocessor and an associated memory. Controller 52 is configured to control the operation of imaging system 10. System controller 52 provides delay commands to the transmit beamformer channels via a bus 54. The delay data steers and focuses the generated transmit beams over transmit scan lines of a wedge-shaped transmit pattern, a parallelogram-shaped transmit pattern, or other patterns.

The system controller 52 also provides delay commands to the channels of the receive beamformer via a bus 56. The applied relative delays control the steering and focusing of the synthesized receive beams. Each receive beamformer channel 44_i includes a variable gain amplifier, which controls gain as a function of received signal depth, and a delay element that delays acoustic data to achieve beam steering and dynamic focusing of the synthesized beam. Summing element 48 receives the outputs from beamformer channels and adds the outputs to provide the resulting beamformer signal 50 to an image generator 58.

The beamformer signal represents a receive ultrasound beam synthesized along a receive scan line. Image generator 58 constructs an image of a region probed by a multiplicity of round-trip beams synthesized over a sector-shaped pattern, a parallelogram-shaped pattern or other patterns.

The transmit beamformer may include an analog or digital beamformer as described, for example, in U.S. Pat. Nos. 4,140,022; 5,469,851; or 5,345,426 all of which are incorporated by reference.

Alternatively, the transmit beamformer may use the same analog delay element as the receive beamformer. In this arrangement switches are used to switch the analog delay circuits to delay transmit signals during transmit and to delay receive signals during signal reception. The analog delay circuitry can be used to delay either analog signals or digital pulses.

Referring again to FIG. 3, receive beamformer 40 comprises an analog receive beamformer including a set of programmable delay lines 46_1 , 46_2 , 46_3 , and 46_N connected to a summing element 48. The output 50 of summing element 48 provides the delayed and summed signals of receive beamformer 40. Programmable delay lines 46_i are implemented as analog delay lines. Each analog delay line 46_i includes an analog RAM as is described in connection with FIG. 4.

As discussed herein, the ultrasound system includes an array of transducer elements. The transducer elements are operatively coupled to receive beamformer channels, the beamformer channels including analog delay lines, the delay being configurable.

5 Referring now to FIG. 4, analog random access memory (RAM) device 60 is configured as a programmable delay element. RAM device 60 includes a group of M storage capacitors $62_1, 62_2, 62_3, \dots, 62_M$ for storing M input sample signals using decoders 64 and 68 connected to input switches $65_1, 65_2, \dots, 65_M$ and output switches $67_1, 67_2, \dots, 67_M$, respectively. An input buffer 68 receives a transducer signal that is then sent
10 by input switch 65_i controlled by decoder 64 to storage capacitor 62_i . Decoder 66 coupled to output switch 67_i samples the individual capacitor charges at delay times determined by the difference in timing between an input counter 70 and an output counter 72. Accordingly, the transducer signals are delayed by selected delay times as they are transferred from input buffer 68 to an output buffer 74.

15 In one embodiment, the time difference between the two counters 70 and 72 is held at a constant value for all pixels along an acoustic line by making the clocks (CLK1 and CLK2) to the two counters identical. This embodiment provides a fixed static focus.

In another embodiment, the time difference between the two counters 70 and 72 is varied along an acoustic line by using different clocks for the two counters. By choosing
20 appropriate pulse streams for the two clocks, focus can be maintained for all pixels along the acoustic line. This embodiment provides dynamic focusing.

Referring again to FIG. 2, the imaging system 10 includes system controller 52 with a digital control circuit configured to provide delay values to the transmit and receive beamformers, as shown diagrammatically by data buses 54 and 56. Both transmit and
25 receive beamformers are configured to receive delay values by these data buses.

As disclosed herein, a phased array ultrasound scanning apparatus includes a one-dimensional (1-D) array of ultrasound transducer elements including transmit and receive elements. The 1-D array is responsive to a transmitter configured to energize the transmit elements for generating a transmit acoustic beam directed into a region of interest. The
30 apparatus further includes a receive beamformer operatively connected to the 1-D array. The receive beamformer is configured to synthesize receive beams, in response to echoes of the transmit acoustic beam received from the region of interest. In addition, the receive

beamformer includes analog random access memory (aRAM) elements configured to delay signals received from the receive elements and provide the delayed signals on an output of the receive beamformer as a beamformed RF output. The receive beamformer further includes a summer configured to sum the delayed signals and to generate the beamformed RF output in response to the sum of the delayed signals. The beamformed RF output is suitable for use in forming an image of the region of interest.

In one embodiment, the receive beamformer is configured to implement static beamforming. With static beamforming, the beamformed RF output is suitable for use in forming the image by splicing to produce consistent resolution through a greater depth of field. Splicing employs multiple transmit events per scan line in a given direction, each transmit event focused at successively shallower depths. The received acoustic data sets from the successive events are collected by the system processor, and adjacent sections from the successive data sets are excerpted so that their data is near the corresponding transmit event's focus. The excerpted data sets are combined into one composite receive line with superior depth of regard than any of the supplier receive lines. The splicing process is repeated for every scan line of the overall image scan.

In another embodiment, the receive beamformer is configured to implement dynamic beamforming, including dynamically updating delay values with time so as to maintain focus for all pixels along an acoustic line.

The phased array ultrasound scanning apparatus further includes suitable detector, including hardware and software, for detecting the image of the region of interest in response to the beamformed RF output. In addition, the apparatus includes a display unit, operatively connected to the detector, for displaying the detected image. A user interface is operatively connected to the image detector and display unit, the user interface configured to control a control parameter of at least one of the image detector and the display unit. In one embodiment, the image detector, display, and user interface comprise one or more of a portable personal computer (PC), a Personal Digital Assistant (PDA), and a pocket PC.

In one embodiment, the transducer array, receive beamformer, image detector, and display comprise a single package. In another embodiment, the transducer array and receive beamformer comprise a first package, and the image detector and display comprise a second package, wherein the first package is operatively coupled to the second package.

According to yet another embodiment, the transducer array is in one package, and the receive beamformer, image detector and display are in a second package.

In one embodiment of the invention, statically focused RF is used to form an image of an area of interest. It is recognized that this embodiment has a problem associated with the limited depth of field resulting from static focus beamforming. However, the reduced
5 complexity and lower cost may make this problem acceptable.

With static focus, depth of field can be increased by splicing receive data from multiple acoustic lines with different transmit foci.

As indicated above, the receive beamformer can be modified to adjust the receive
10 delays during reception, allowing a continuously focused summation of channel data into the single RF signal. Accordingly, the beamformer can be configured for dynamic focus.

With the embodiment discussed above, no beamforming is needed external to the probe. Simple image detection can be done on an interface board that plugs directly into a portable PC, such as a notebook, palmtop, or a personal digital assistant (PDA). The
15 circuitry required for the ultrasound data acquisition and beamforming is provided within the probe itself. An interface couples the probe to the PC. Image detection, formatting, and display are performed by suitable hardware and software in the PC, using beamformed RF data from the probe. The beamformed RF data is transferred on a single analog or digital channel from the probe to the interface. The interface can include a standard interface such
20 as Compact Flash (CF or CF+), PCMCIA, USB, FireWire, FibreChannel, PCI, UART, or other suitable interface

Although only a few exemplary embodiments have been described in detail above, those skilled in the art will readily appreciate that many modifications are possible in the exemplary embodiments without materially departing from the novel teachings and
25 advantages of the embodiments of the present disclosure.

For example, one can split the beamformer into one or more stages with the first stage beamforming sub-arrays of elements and the second stage beamforming the outputs of the sub-array beamformers. In another example, one could use sample and hold devices or switched capacitor devices or charge coupled devices instead of the ARAM for the
30 analog delay elements. Accordingly, all such modifications are intended to be included within the scope of the embodiments of the present disclosure as defined in the following claims. In the claims, means-plus-function clauses are intended to cover the structures

described herein as performing the recited function and not only structural equivalents, but also equivalent structures.

CLAIMS:

1. A phased array ultrasound scanning apparatus comprising:
a one-dimensional (1-D) array of ultrasound transducer elements including transmit and receive elements, said 1-D array responsive to a transmitter configured to energize the transmit elements for generating a transmit acoustic beam directed into a region of interest; and
a receive beamformer operatively connected to said 1-D array, said receive beamformer configured to synthesize receive beams, in response to echoes of the transmit acoustic beam received from the region of interest, said receive beamformer including analog random access memory (aRAM) elements configured to delay signals received from the receive elements and provide the delayed signals on an output of said receive beamformer as a beamformed RF output, the beamformed RF output suitable for use in forming an image of the region of interest.
2. The apparatus of claim 1, wherein said 1-D array includes one selected from the group consisting of a phased array, a linear phased array, and a curved linear phased array.
3. The apparatus of claim 1, wherein said receive beamformer is configured to implement static focusing.
4. The apparatus of claim 3, wherein the beamformed RF output is suitable for use in forming the image by splicing to produce consistent resolution through a greater depth of field.
5. The apparatus of claim 1, wherein said receive beamformer is configured to implement dynamic focusing.
6. The apparatus of claim 1, further comprising:
means for detecting the image of the region of interest in response to the beamformed RF output; and
means, operatively connected to said detecting means, for displaying the detected image.
7. The apparatus of claim 6, wherein said transducer array, said receive beamformer, said image detection means, and said display means comprise a single package.
8. The apparatus of claim 6, wherein said transducer array and said receive beamformer comprise a first package, and said image detection means and said display means comprise a second package, wherein the first package is operatively coupled to the second package.

9. The apparatus of claim 6, wherein said transducer array comprises a first package, and said receive beamformer, said image detection means and said display means comprise a second package, wherein the first package is operatively coupled to the second package.

10. The apparatus of claim 6, further comprising:

a user interface operatively connected to said image detection means and said display means, said user interface configured to control a control parameter of at least one of said image detection means and said display means.

11. The apparatus of claim 10, wherein said image detection means, said display means, and said user interface comprise one selected from the group consisting of a portable personal computer (PC), a Personal Digital Assistant (PDA), and a pocket PC.

12. The apparatus of claim 10, wherein one or more of said control parameters and acoustic data signals is transferred to said detecting means and to said display means by an interface selected from the group consisting of Compact Flash (CF and CF+), PCMCIA, USB, FireWire, FibreChannel, PCI, and UART.

13. A phased array ultrasound scanning apparatus comprising:

a one-dimensional (1-D) array of ultrasound transducer elements including transmit and receive elements, said 1-D array responsive to a transmitter, configured to energize the transmit elements for generating a transmit acoustic beam directed into a region of interest;

a receive beamformer operatively connected to said 1-D array, said receive beamformer configured to synthesize receive beams, in response to echoes of the transmit acoustic beam received from the region of interest, said receive beamformer including analog random access memory (aRAM) elements configured to delay signals received from the receive elements and provide the delayed signals on an output of said receive beamformer as a beamformed RF output, the beamformed RF output suitable for use in forming an image of the region of interest;

means for detecting the image of the region of interest in response to the beamformed RF output; and

means, operatively connected to said detecting means, for displaying the detected image, wherein said transducer array, said receive beamformer, said image detection means, and said display means together comprise a configuration of at least one selected from the group consisting of individual physical units operatively coupled together and combinations of physical units operatively coupled together.

14. A method for phased array ultrasound scanning comprising:
 - providing a one-dimensional (1-D) array of ultrasound transducer elements including transmit and receive elements, the 1-D array responsive to a transmitter configured to energize the transmit elements for generating a transmit acoustic beam directed into a region of interest; and
 - configuring a receive beamformer to operatively connect to the 1-D array and to synthesize receive beams in response to echoes of the transmit acoustic beam received from the region of interest, the receive beamformer including analog random access memory (aRAM) elements configured to delay signals received from the receive elements and provide the delayed signals on an output of the receive beamformer as a beamformed RF output, the beamformed RF output suitable for use in forming an image of the region of interest.
15. The method of claim 14, wherein the 1-D array includes one selected from the group consisting of a phased array, a linear phased array, and a curved linear phased array.
16. The method of claim 14, further comprising configuring the receive beamformer to implement static focusing.
17. The method of claim 16, wherein the beamformed RF output is suitable for use in forming the image by splicing to produce consistent resolution through a greater depth of field.
18. The method of claim 14, further comprising configuring the receive beamformer to implement dynamic focusing.
19. The method of claim 14, further comprising:
 - detecting, via an image detector, the image of the region of interest in response to the beamformed RF output; and
 - displaying, via a display, the detected image.
20. The method of claim 19, further comprising:
 - combining the transducer array, the receive beamformer, an image detector, and a display into a single package.
21. The method of claim 19, further comprising:
 - combining the transducer array, receive beamformer, detector, and display into at least one of multiple combinations of packages
22. The method of claim 19, further comprising:

configuring a user interface to control a control parameter of at least one of the image detector and the display.

23. The method of claim 22, wherein the image detector, display, and user interface comprise one selected from the group consisting of a portable personal computer (PC), a Personal Digital Assistant (PDA), and a pocket PC.

24. The method of claim 22, wherein one or more of the control parameter and acoustic data signals is transferred to the image detector and the display by an interface selected from the group consisting of Compact Flash (CF and CF+), PCMCIA, USB, FireWire, FibreChannel, PCI, and UART.

25. A method of phased array ultrasound scanning comprising:

providing a one-dimensional (1-D) array of ultrasound transducer elements including transmit and receive elements, the 1-D array responsive to a transmitter configured to energize the transmit elements for generating a transmit acoustic beam directed into a region of interest;

configuring a receive beamformer to operatively connect to the 1-D array and to synthesize receive beams in response to echoes of the transmit acoustic beam received from the region of interest, the receive beamformer including analog random access memory (aRAM) elements configured to delay signals received from the receive elements and provide the delayed signals on an output of the receive beamformer as a beamformed RF output, the beamformed RF output suitable for use in forming an image of the region of interest;

detecting, via an image detector, the image of the region of interest in response to the beamformed RF output; and

displaying, via a display, the detected image, wherein the transducer array, receive beamformer, image detector, and display together comprise a configuration of at least one of multiple combinations of packages operatively coupled together.

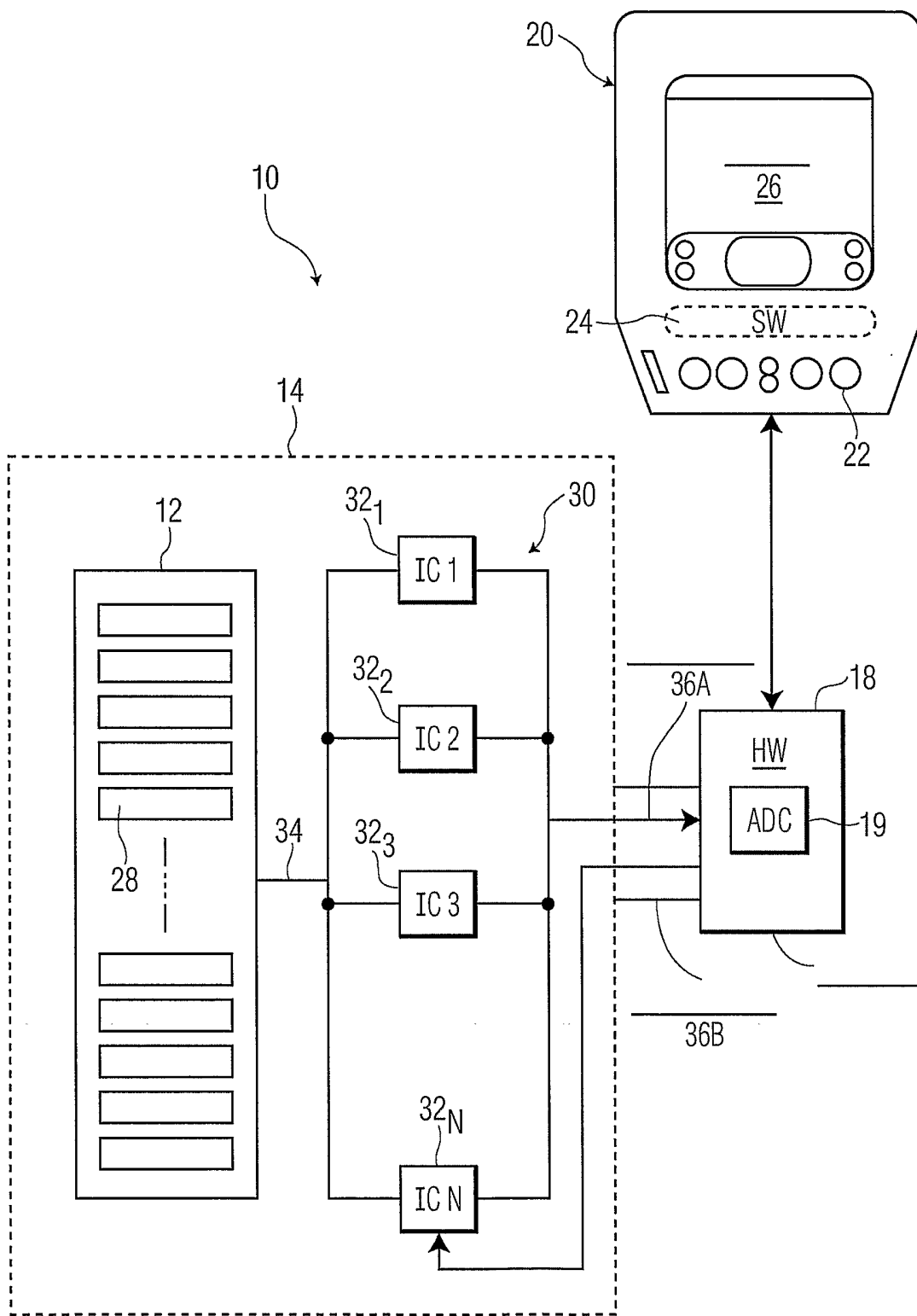

FIG. 1

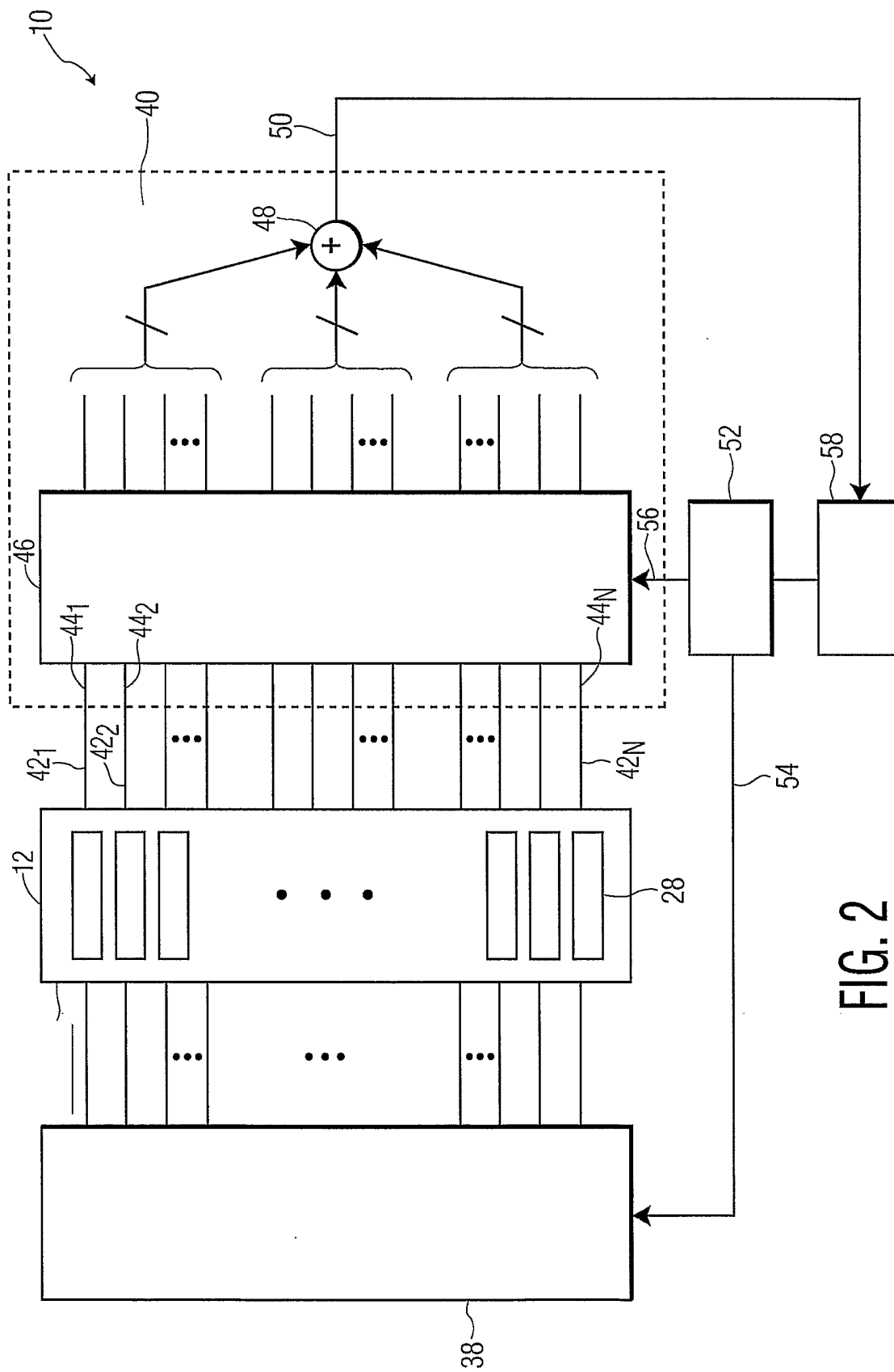

FIG. 2

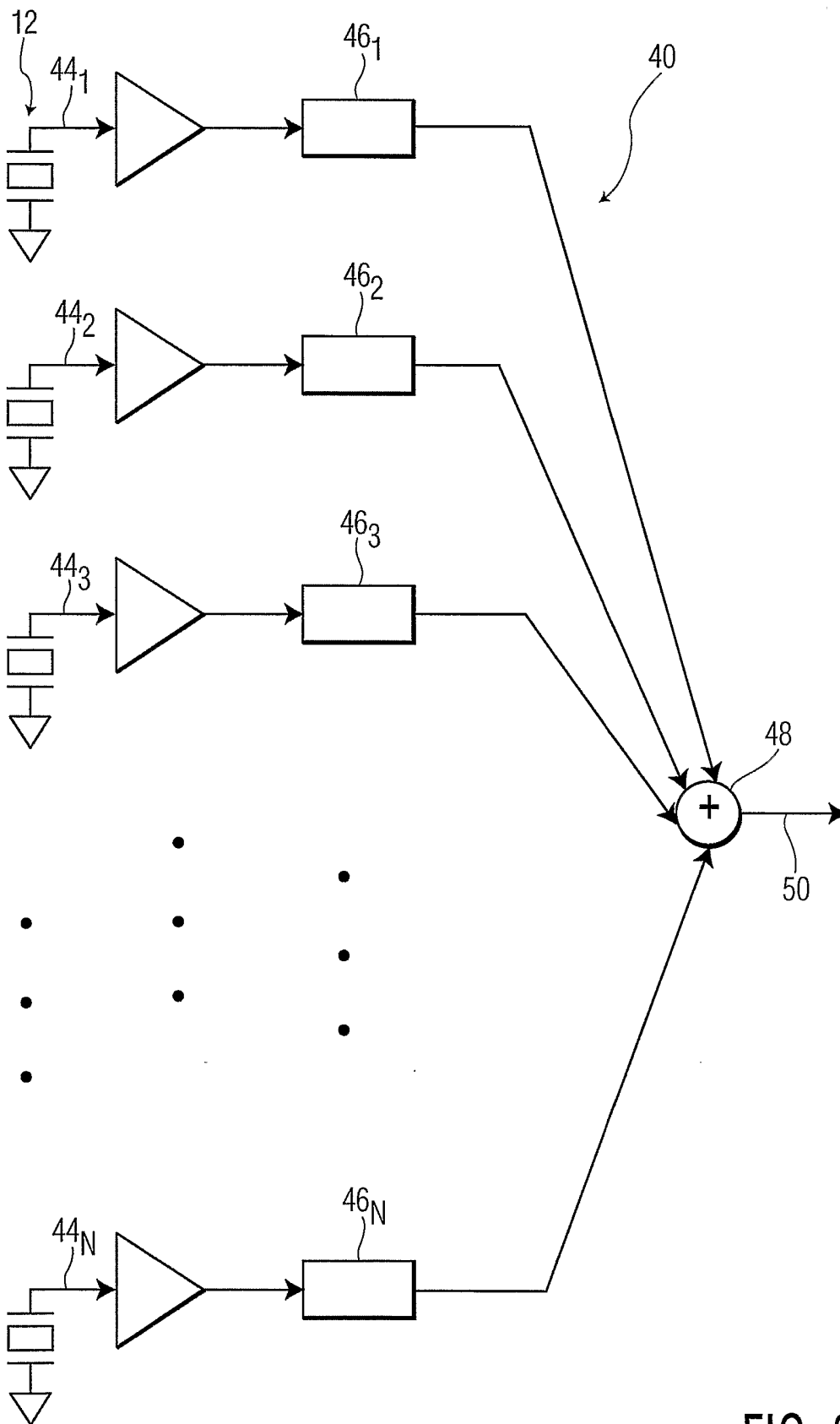

FIG. 3

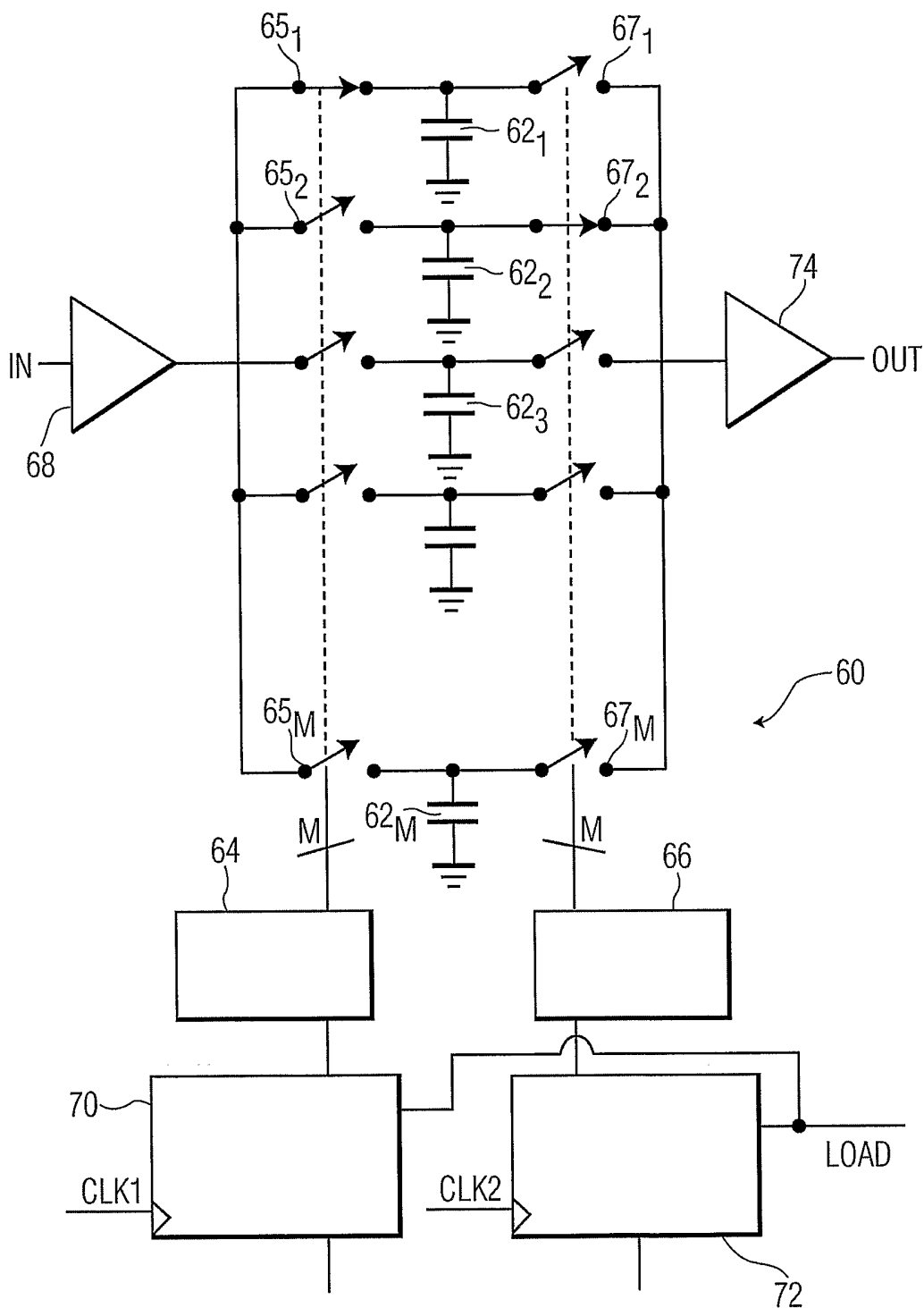

FIG. 4

INTERNATIONAL SEARCH REPORT

Internatic plication No
PCT/IB 03/03999

A. CLASSIFICATION OF SUBJECT MATTER

IPC 7 G01S15/89 G01S7/52 G10K11/34

According to International Patent Classification (IPC) or to both national classification and IPC

B. FIELDS SEARCHED

Minimum documentation searched (classification system followed by classification symbols)
IPC 7 G01S G10K

Documentation searched other than minimum documentation to the extent that such documents are included in the fields searched

Electronic data base consulted during the international search (name of data base and, where practical, search terms used)

EPO-Internal, INSPEC, WPI Data

C. DOCUMENTS CONSIDERED TO BE RELEVANT

Category °	Citation of document, with indication, where appropriate, of the relevant passages	Relevant to claim No.
X Y	US 4 019 169 A (TAKAMIZAWA KINYA) 19 April 1977 (1977-04-19) column 1, line 50 -column 2, line 25 column 7, line 60 -column 9, line 19; figures 1,7 ---	1-7, 14-20 8-13, 21-25
Y	US 6 440 072 B1 (MARSHALL JANICE L ET AL) 27 August 2002 (2002-08-27) column 1, line 8 - line 14; claims; figures abstract ---	8-13, 21-25
A	US 4 387 597 A (BRANDESTINI MARCO A) 14 June 1983 (1983-06-14) abstract; figure 6A --- -/--	1,13,14, 25

Further documents are listed in the continuation of box C.

Patent family members are listed in annex.

° Special categories of cited documents :

- *A* document defining the general state of the art which is not considered to be of particular relevance
- *E* earlier document but published on or after the international filing date
- *L* document which may throw doubts on priority claim(s) or which is cited to establish the publication date of another citation or other special reason (as specified)
- *O* document referring to an oral disclosure, use, exhibition or other means
- *P* document published prior to the international filing date but later than the priority date claimed

- *T* later document published after the international filing date or priority date and not in conflict with the application but cited to understand the principle or theory underlying the invention
- *X* document of particular relevance; the claimed invention cannot be considered novel or cannot be considered to involve an inventive step when the document is taken alone
- *Y* document of particular relevance; the claimed invention cannot be considered to involve an inventive step when the document is combined with one or more other such documents, such combination being obvious to a person skilled in the art.
- *&* document member of the same patent family

Date of the actual completion of the international search <p style="text-align: center; font-size: 1.2em;">8 January 2004</p>	Date of mailing of the international search report <p style="text-align: center; font-size: 1.2em;">15/01/2004</p>
Name and mailing address of the ISA European Patent Office, P.B. 5818 Patentlaan 2 NL - 2280 HV Rijswijk Tel. (+31-70) 340-2040, Tx. 31 651 epo nl, Fax: (+31-70) 340-3016	Authorized officer <p style="text-align: center; font-size: 1.2em;">Devine, J</p>

INTERNATIONAL SEARCH REPORT

Internatic plication No
PCT/IB 03/03999

C.(Continuation) DOCUMENTS CONSIDERED TO BE RELEVANT		
Category °	Citation of document, with indication, where appropriate, of the relevant passages	Relevant to claim No.
A	US 4 962 667 A (OGAWA TOSHIO ET AL) 16 October 1990 (1990-10-16) column 5, line 11 - line 35; figure 9A -----	1,13,14, 25
A	US 5 345 426 A (LIPSCHUTZ DAVID) 6 September 1994 (1994-09-06) cited in the application the whole document -----	1-25
A	US 4 140 022 A (MASLAK SAMUEL H) 20 February 1979 (1979-02-20) cited in the application the whole document -----	1-25
A	US 5 469 851 A (LIPSCHUTZ DAVID) 28 November 1995 (1995-11-28) cited in the application the whole document -----	1-25

INTERNATIONAL SEARCH REPORT

Information on patent family members

Internatic	Application No
PCT/IB 03/03999	

Patent document cited in search report	Publication date	Patent family member(s)	Publication date	
US 4019169	A	19-04-1977	JP 51043879 A	14-04-1976
			AU 500496 B2	24-05-1979
			AU 8511275 A	31-03-1977
			DE 2543678 A1	01-04-1976
			GB 1527382 A	04-10-1978
			NL 7511423 A	01-04-1976
US 6440072	B1	27-08-2002	NONE	
US 4387597	A	14-06-1983	AT 29185 T	15-09-1987
			CA 1175134 A1	25-09-1984
			DE 3176390 D1	01-10-1987
			EP 0053834 A1	16-06-1982
			JP 57122857 A	30-07-1982
US 4962667	A	16-10-1990	JP 1938906 C	09-06-1995
			JP 6064022 B	22-08-1994
			JP 62083656 A	17-04-1987
			JP 62084748 A	18-04-1987
			DE 3634504 A1	16-04-1987
US 5345426	A	06-09-1994	DE 4402098 A1	17-11-1994
			JP 3442471 B2	02-09-2003
			JP 7051266 A	28-02-1995
US 4140022	A	20-02-1979	DE 2854134 A1	21-06-1979
			FR 2412854 A1	20-07-1979
			GB 2010482 A ,B	27-06-1979
			GB 2097924 A ,B	10-11-1982
			JP 54096286 A	30-07-1979
			JP 58016892 B	02-04-1983
US 5469851	A	28-11-1995	EP 0696792 A2	14-02-1996
			JP 8056944 A	05-03-1996