

(No Model.)

G. J. BURNS.  
PAPER DRYING APPARATUS.

No. 602,799.

Patented Apr. 19, 1898.

FIG. 1.

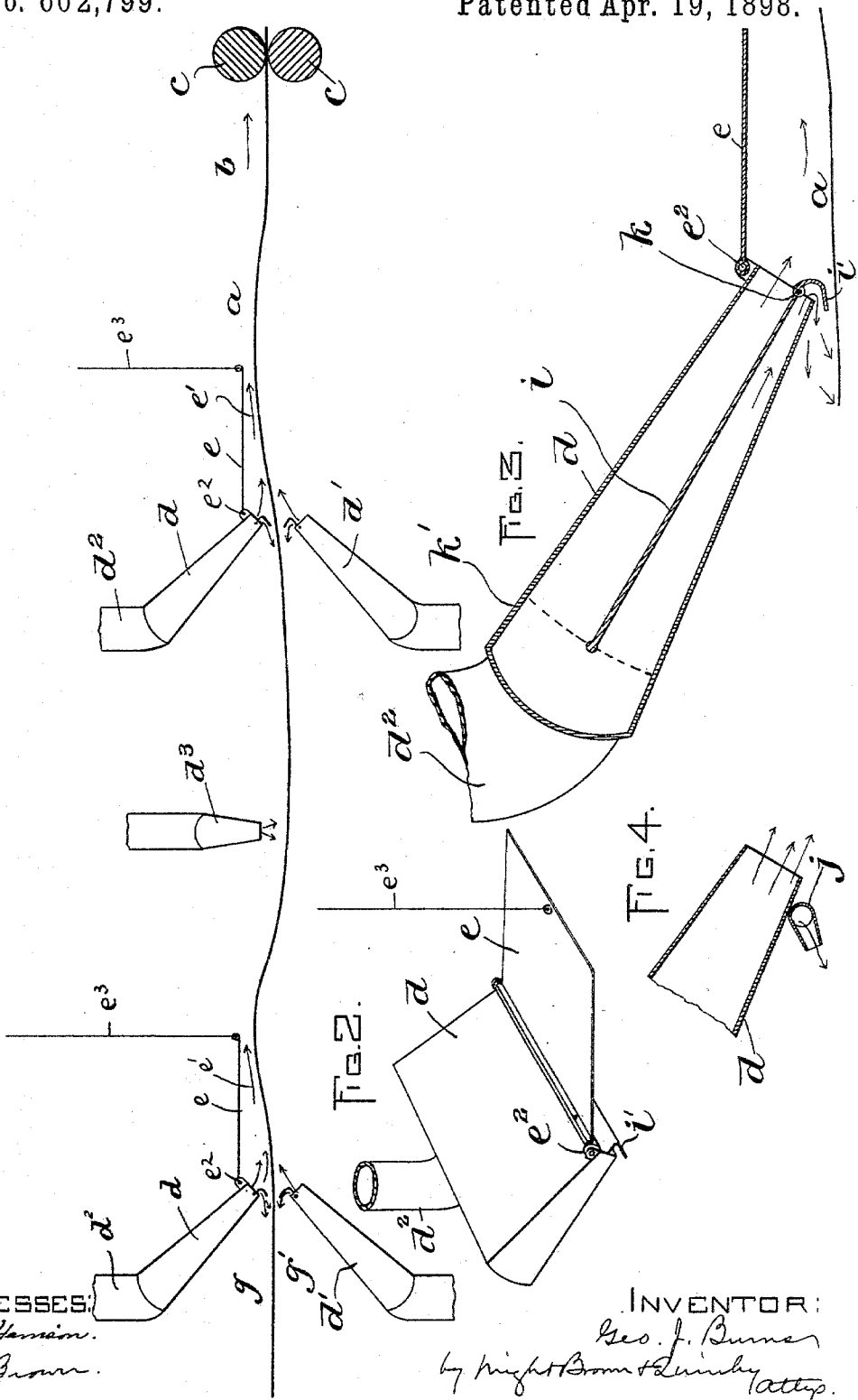

WITNESSES:  
A. D. Hanson.  
H. W. Brown.

INVENTOR:  
Geo. J. Burns  
by Knight, Brown & Linsley attys.

# UNITED STATES PATENT OFFICE.

GEORGE J. BURNS, OF AYER, MASSACHUSETTS.

## PAPER-DRYING APPARATUS.

SPECIFICATION forming part of Letters Patent No. 602,799, dated April 19, 1898.

Application filed June 18, 1897. Serial No. 641,241. (No model.)

To all whom it may concern:

Be it known that I, GEORGE J. BURNS, of Ayer, in the county of Middlesex and State of Massachusetts, have invented certain new and useful Improvements in Paper-Drying Apparatus, of which the following is a specification.

This invention relates to apparatus for drying a web of paper which has been coated with coloring-matter, usually containing clay, the object of the coating being to produce a specially-prepared surface upon the paper adapted to receive impressions from half-tone cuts. While the coating is in a damp condition upon the paper it is very easily marred or scratched by contact with any devices which may be used to positively support the paper in its progressive movement from the coating devices.

My invention has for its object to provide means for supporting all portions of the web on which the coating is damp wholly by atmospheric pressure and for drying the coating while thus supported and before it can come in contact with any positive supporting device, such as a roll.

The invention consists in the improvements which I will now proceed to describe and claim.

Of the accompanying drawings, forming a part of this specification, Figure 1 represents a longitudinal section, showing the parts of a paper-drying machine which embody the features of novelty invented by me. Fig. 2 represents a perspective view of one of the air-delivering nozzles shown in Fig. 1. Fig. 3 represents an enlarged sectional view of the nozzle shown in Fig. 2. Fig. 4 represents a modification hereinafter referred to.

The same letters of reference indicate the same parts in all the figures.

In the drawings, *a* represents a web of paper, which is progressively moved in the direction indicated by the arrow *b* in Fig. 1 by suitable feeding means, such as a pair of positively-driven feed-rolls *cc*, between which the web passes from the devices which apply the coating.

I do not show the coating devices, as they may be of any suitable character, suitable coating devices being in common use and well known.

*d* represents an air-delivering nozzle, which

is suitably connected with an air-forcing apparatus, such as a fan-blower, and is arranged to deliver a blast of air obliquely upon the upper side of the web *a* and either in approximately the direction of motion of the web or in approximately the opposite direction.

*e* represents a plate or air-guide extending from the mouth of said nozzle or from a point near said mouth and forming one side of an air-passage *e'*, arranged to receive the blast of air, the other side of said passage being formed by the portion of the web *a* which is passing under the said guide. It will be seen that the blast of air delivered by the nozzle *d* in passing through the passage *e'* causes an increase of atmospheric pressure upon the walls of said passage, and as the wall formed by the web *a* is flexible, the atmospheric pressure having a tendency to contract the passage *e'*, lifts the flexible wall thereof—namely, that portion of the web which is passing under the guide. The result is that the said portion of the web is floated or suspended in the air without contact with any substance or object which can mar or injure its coating, the air-blast in the passage *e'* preventing the web from touching the guide *e*, while the pressure of the external air prevents contact of the web with any object below the guide *e*. I find that I can in this way effectually support a long section of partially-coated web and insure its freedom from contact with any solid object. The air delivered by the nozzle *d* is preferably heated to facilitate the drying of the coating.

If the paper is coated on both sides, a similar nozzle *d'* is arranged to deliver a blast of air against the under side of the web at a point immediately opposite the nozzle *d*, this lower blast being also, preferably, heated and serving not only to dry the coating on the under side of the web, but also to assist the action of the atmospheric pressure in floating or supporting the portion of the web under the coating.

The air-guide *e* is preferably adjustable vertically. I have here shown said guide hinged at *e<sup>2</sup>* to a fixed support, which may be the nozzle *d*, its opposite edge being adapted to swing toward and from the web and supported by a cord or chain *e<sup>3</sup>*, by means of

which the height of the swinging edge may be varied. By raising the swinging edge of the air-guide the height at which the adjacent portion of the web is supported by atmospheric pressure is correspondingly raised, or by depressing the swinging edge of the air-guide the web is supported at a correspondingly-depressed position.

I find by experiment that the force of the air-blast delivered by the nozzle  $d$  determines the atmospheric pressure upon the guide  $e$  and upon the adjacent portion of the web.

It will be seen that the nozzles  $d$  and  $d'$ , arranged obliquely with relation to the web, form V-shaped spaces  $g$   $g'$ , into which external air is drawn by the vacuum created by the blast of air delivered upon the web. To prevent cold air, as well as air laden with dust, from being thus brought into contact with the portions of the web upon which the air-blasts impinge, I provide means for directing blasts of air backwardly or in a direction substantially opposite to the directions of the blasts delivered by the nozzles  $d$   $d'$ , the said backward blasts of air forming, as it were, atmospheric dams, which prevent the access of air to the web through the spaces  $g$   $g'$ . In Figs. 1 and 3 I show as the means for accomplishing this result partitions  $i$  in the nozzles  $d$   $d'$ , each partition having a backwardly-extending lip  $i'$  at the mouth of the nozzle arranged to deflect portions of the air passing through the nozzles, as clearly indicated in Fig. 3.

In Fig. 4 an air-passage  $j$  is shown as formed upon the rear side of the nozzle  $d$ , said passage receiving air through an independent supply-pipe and having an outlet or outlets arranged to deliver the air backwardly upon the surface of the web.

The passage  $j$  is preferably adjustably supported, so that it can be turned to vary the angle at which the backward air-blast is delivered through its outlet or outlets.

The partition  $i$  is preferably pivoted at  $k$  to the nozzle or to any suitable support and is free to swing at its end  $k'$ , so that it may be adjusted to deflect any desired portion of the air passing through the nozzle, provision being thus made for varying the force of the backward blast. Any suitable means may be provided for securing the partition  $i$  in any position to which it may be adjusted.

In practice a series of nozzles  $d$  and accompanying air-guides or floaters  $e$  will be employed, the number depending on the weight of the web and its coating. For drying coated paper, such as is used for half-tone printing, I find it advisable to employ two or more nozzles and floaters and to locate each nozzle and floater about ten feet from the next.

In case it is found that the upward displacement of the web is too great the lower nozzles

$d'$  may be arranged to alternate with the upper nozzles  $d$  instead of being directly under them, or I may arrange a nozzle  $d^3$  between each nozzle  $d$  and the next, the nozzles  $d^3$  directing blasts of air downwardly on the web and limiting its upward displacement under the guides  $e$ .

It is obvious that my invention may be used for drying coatings applied to a web of any flexible material adapted to be supported in the manner described—such, for example, as window-shade cloth.

I claim—

1. A paper-drying apparatus comprising an air-delivering nozzle, a plate or air-guide adjacent to the delivering end of said nozzle and extending from the delivering end thereof, and means for feeding a web of paper along one side of the air-guide, the said guide and web forming opposite sides of an air-passage which receives a blast of air from the nozzle, the web being floated or sustained by atmospheric pressure caused by the current of air forced through said passage.

2. A paper-drying apparatus comprising an air-delivering nozzle, a plate or air-guide forming one side of an air-passage which receives a blast of air from said nozzle, means for feeding a web of paper in such relation to the nozzle and air-guide as to cause the web to form the other side of said passage, and a second nozzle arranged to deliver a blast of air against the opposite side of the web.

3. A paper-drying apparatus comprising web-feeding means, an air-delivering nozzle arranged to deliver a blast of air obliquely against the web in approximately the direction of movement of the latter, and means for delivering a blast of air upon the web in substantially the opposite direction or backwardly with relation to the movement of the web immediately in advance of the point of impingement of the first-mentioned blast.

4. A paper-drying apparatus comprising web-feeding means, an air-delivering nozzle arranged to deliver a blast of air obliquely against the web in the direction of movement of the latter, and a longitudinal partition within the nozzle, formed to subdivide the blast of air passing therethrough into two parts, said partition having a deflector at one end arranged to deflect one of the parts of the blast.

In testimony whereof I have signed my name to this specification, in the presence of two subscribing witnesses, this 4th day of June, A. D. 1897.

GEORGE J. BURNS.

Witnesses:

WARREN H. ATWOOD,  
JAMES W. GILDAY.