



INTERNATIONAL APPLICATION PUBLISHED UNDER THE PATENT COOPERATION TREATY (PCT)

<p>(51) International Patent Classification <sup>6</sup> : H04N 7/14, 5/44, H04M 11/00, 3/42</p>	<p>A1</p>	<p>(11) International Publication Number: <b>WO 96/41476</b> (43) International Publication Date: 19 December 1996 (19.12.96)</p>
<p>(21) International Application Number: PCT/US96/10017 (22) International Filing Date: 7 June 1996 (07.06.96) (30) Priority Data: 08/482,991 7 June 1995 (07.06.95) US (71) Applicant: IMAGETEL INTERNATIONAL, INC. [US/US]; 11177 Bluegrass Parkway, Louisville, KY 40299 (US). (72) Inventors: GREGORY, Earl, A., III; 2033 Alta Avenue #2, Louisville, KY 40205 (US). HEIBERT, R., Dean; 8511 Bayou Way, Louisville, KY 40242 (US). FAUTH, Mark; 7712 Poinsetta Drive, Louisville, KY 40258 (US). SHKILER, Aleksandr; 3218 Hikes Lane #138, Louisville, KY 40220 (US). (74) Agents: LONGANECKER, Stacey, J. et al.; Roylance, Abrams, Berdo &amp; Goodman, L.L.P., Suite 315, 1225 Connecticut Avenue, N.W., Washington, DC 20036 (US).</p>	<p>(81) Designated States: AL, AM, AT, AT (Utility model), AU, AZ, BB, BG, BR, BY, CA, CH, CN, CZ, CZ (Utility model), DE, DE (Utility model), DK, DK (Utility model), EE, EE (Utility model), ES, FI, FI (Utility model), GB, GE, HU, IL, IS, JP, KE, KG, KP, KR, KZ, LK, LR, LS, LT, LU, LV, MD, MG, MK, MN, MW, MX, NO, NZ, PL, PT, RO, RU, SD, SE, SG, SI, SK, SK (Utility model), TJ, TM, TR, TT, UA, UG, UZ, VN, ARIPO patent (KE, LS, MW, SD, SZ, UG), Eurasian patent (AM, AZ, BY, KG, KZ, MD, RU, TJ, TM), European patent (AT, BE, CH, DE, DK, ES, FI, FR, GB, GR, IE, IT, LU, MC, NL, PT, SE), OAPI patent (BF, BJ, CF, CG, CI, CM, GA, GN, ML, MR, NE, SN, TD, TG).</p> <p><b>Published</b> With international search report. With amended claims.</p>	

(54) Title: VIDEOCONFERENCING AND MULTIMEDIA SYSTEM

(57) Abstract

A videoconferencing and multimedia system is provided which comprises a personal computer (70) having an infrared and logic-level control board (86) in a peripheral slot thereof for controlling devices (16, 22, 24, 42, 44) therein via transistor-transistor logic-level signals, serial infrared signals and/or analog control signals such as variable-voltage level signals. The infrared and logic-level control board (86) processes feedback signals for board and external device diagnostics. The multiple nodes (142a-142d) in the videoconferencing system are networked using an audio and video communication link (162) and a parallel control data communication link (158). Another information transfer communication link (160) can be used on demand for file sharing and data transfer operations outside the bandwidth of the videoconference. Nodes (142a-142d) can be in a local area network (148) which is connected to a wide area network (150) via a gateway (152).

**FOR THE PURPOSES OF INFORMATION ONLY**

Codes used to identify States party to the PCT on the front pages of pamphlets publishing international applications under the PCT.

AM	Armenia	GB	United Kingdom	MW	Malawi
AT	Austria	GE	Georgia	MX	Mexico
AU	Australia	GN	Guinea	NE	Niger
BB	Barbados	GR	Greece	NL	Netherlands
BE	Belgium	HU	Hungary	NO	Norway
BF	Burkina Faso	IE	Ireland	NZ	New Zealand
BG	Bulgaria	IT	Italy	PL	Poland
BJ	Benin	JP	Japan	PT	Portugal
BR	Brazil	KE	Kenya	RO	Romania
BY	Belarus	KG	Kyrgystan	RU	Russian Federation
CA	Canada	KP	Democratic People's Republic of Korea	SD	Sudan
CF	Central African Republic	KR	Republic of Korea	SE	Sweden
CG	Congo	KZ	Kazakhstan	SG	Singapore
CH	Switzerland	LI	Liechtenstein	SI	Slovenia
CI	Côte d'Ivoire	LK	Sri Lanka	SK	Slovakia
CM	Cameroon	LR	Liberia	SN	Senegal
CN	China	LT	Lithuania	SZ	Swaziland
CS	Czechoslovakia	LU	Luxembourg	TD	Chad
CZ	Czech Republic	LV	Latvia	TG	Togo
DE	Germany	MC	Monaco	TJ	Tajikistan
DK	Denmark	MD	Republic of Moldova	TT	Trinidad and Tobago
EE	Estonia	MG	Madagascar	UA	Ukraine
ES	Spain	ML	Mali	UG	Uganda
FI	Finland	MN	Mongolia	US	United States of America
FR	France	MR	Mauritania	UZ	Uzbekistan
GA	Gabon			VN	Viet Nam

## VIDEOCONFERENCING AND MULTIMEDIA SYSTEM

This application is a continuation-in-part of U.S. patent application Serial No. 08/440,966, filed May 15, 1995, the entirety of which is hereby incorporated herein by reference for all purposes.

5

Field of the Invention

The invention relates to a videoconferencing and multimedia system for bi-directional transmission of voice, image data and other data among geographically distributed users.

10

Background of the Invention

5 The development of two-way videoconferencing systems has provided individuals, who are geographically distributed, with the ability to communicate with each other from their respective locations. Thus, the time and expense of several individuals traveling to a single location in order to meet in person is eliminated. The ability to communicate graphic information, as well as see the facial expressions and gestures of conferees, presents significant improvements over audio telecommunication. A number of video telephones have been developed which interface with analog telephone lines. Due to the limited bandwidth of conventional analog telephone lines, however, the amount of information that can be exchanged is limited to less than full motion video and is typically presented on a relatively small display.

10 To overcome bandwidth limitations associated with video telephony transmitted over analog telephone lines, a number of videoconferencing systems have been developed to interface with digital telephone access lines such as an integrated services digital network (ISDN). The increased bandwidth associated with digital access systems has allowed for nearly full motion videoconferencing on larger display devices; however, many of these digital videoconferencing systems continue to transmit video information as "jerky motion" and not smooth video. Further, the audio system associated with many of these devices is not a two-way system, that is, a conferee is interrupted and his or her voice is no longer audible if another conferee speaks simultaneously.

20 Thus, a need remains for improvement of a videoconferencing system to allow for smooth video and bi-directional audio. Further, a need exists for improved integration of the videoconferencing system with multimedia

5 devices for sending, for example, graphic information, as well as audio and video data over a digital network. In particular, a need exists for a videoconferencing system wherein documents and other data can be shared during a videoconference without using bandwidth that is necessary for the transmission of audio and video data.

#### Summary of the Invention

10 In accordance with an aspect of the present invention, a videoconferencing system is provided which comprises a processor; at least one device connected to the processor selected from a group consisting of an audio device and a video device, the device being controlled in accordance with at least one signal type selected from a group  
15 consisting of logic-level signals, serial infrared signals and analog control signals; a control circuit connected to the processor, the processor being programmable to generate a command signal and provide the command signal to the control circuit, the control circuit being configured to process the command signal and to generate an output control signal in accordance with the command signal for  
20 transmission to the device and being at least one of the plurality of signal types that is compatible with the device.

25 In accordance with another aspect of the invention, a videoconferencing system is provided which comprises first and second nodes each having at least one audio input device, at least one video input device, at least one audio output device, at least one video output device and a processor, the second node being operable to receive audio  
30 and video data generated by the audio input device and the video input device of the first node and to transmit to the first node audio and video data generated by the audio input device and the video input device of the second node;

an audio and video data communication link connected to the first node and to the second node; and a control data communication link connected to the first node and to the second node and operable in parallel with the audio and video data communication link. The processor of the first node is programmable to transmit audio and video data generated by its corresponding audio input device and video input device to the second node on the audio and video data communication link, and to generate and transmit control data to the second node on the control data communication link. The processor of the second node is programmable to transmit audio and video data generated by its corresponding audio input device and video input device to the first node on the audio and video data communication link, and to generate and transmit control data to the first node on the control data communication link.

In accordance with yet another aspect of the present invention, a videoconferencing system is provided which also comprises at least one data input device connected to the first node for generating data to be transmitted to the second node during a videoconference; and an information transfer communication link connected to the first node and to the second node and operable in parallel with respect to the control data communication link. The processor in the first node is programmable to transmit the data generated by the data input device to the second node outside the bandwidth of the audio and video data during a videoconference via the information transfer communication link.

#### Brief Description of the Drawings

These and other features and advantages of the present invention will be more readily apprehended from the following detailed description when read in connection with

the appended drawings, which form a part of this original disclosure, and wherein:

Fig. 1 depicts two videoconferencing systems constructed in accordance with an embodiment of the present invention and located at local and remote videoconference sites, respectively;

Fig. 2 is a schematic block diagram of the videoconferencing system depicted in Fig. 1;

Fig. 3 is a schematic block diagram of a videoconferencing system constructed in accordance with another embodiment of the present invention;

Fig. 4 is an illustration of an infrared and logic-level control device for a videoconferencing system in accordance with an embodiment of the present invention;

Fig. 5 is a schematic diagram of the infrared and logic-level control board depicted in Fig. 4 and constructed in accordance with an embodiment of the present invention;

Fig. 6 is a block diagram of network for supporting a videoconferencing system in accordance with an embodiment of the present invention; and

Fig. 7 is a schematic block diagram of two nodes in the network depicted in Fig. 6 and constructed in accordance with an embodiment of the present invention.

## Detailed Description of the Preferred Embodiments

### Overview

Fig. 1 depicts a videoconferencing system 10 located at local videoconference site 12 and constructed in accordance with the present invention, which is in communication with at least one other videoconferencing system 10 located at a remote videoconference site 14. As will be described in further detail below, the videoconferencing system 10 comprises a camera 16, a

projector 18 and screen 20, at least one microphone 22, at least one speaker 24, a user interface 26 such as a touch screen and a control unit 28. The control unit controls these devices, as well as processes audio, video and other data that is received from the remote videoconference site 14 or is about to be transmitted thereto. The system 10 can also comprise a network interface 30 to, for example, a local area network (LAN), at least one auxiliary audio source 32, at least one auxiliary video source 34, a facsimile modem 38, and other multimedia devices such as a graphic image display 40 or video tape recorder (VCR) 42.

Fig. 2 depicts a first embodiment of the videoconferencing system 10 of the present invention which employs a large screen 20, e.g., a seven foot by four foot screen, and is built to be a stationary system in a room designated for multiple person videoconferences.

Fig. 3 depicts a second embodiment of the videoconferencing system 10' of the present invention which employs a portable, roll-around cabinet having a wide-screen 36 inch monitor 44. This embodiment of the present invention is useful for conferees desiring the flexibility of using different rooms for videoconferencing, or who do not wish to dedicate an entire room for videoconferencing.

With reference to Fig. 2, the system 10 is connected to a telecommunications network such as a T1 network or an ISDN by a Channel Service Unit (CSU) 50 or an Inverse Multiplexer (IMUX) 52, respectively. The CSU 50 is preferably a model number MB+1CSU-2P T1/PRI unit manufactured by Ascend Communications, Alameda, California for interfacing with a PRI or T1 network. A model number MB+8PRI IMUX 52 manufactured by Ascend Communications is preferably used to interface with an ISDN.

Data received from the CSU 50 or IMUX 52 is provided to a coder/decoder (CODEC) 54. The CODEC decodes data

- 7 -

received from a remote videoconference site 14 via the T1 or ISDN network. A model number BT VC2300 CODEC manufactured by British Telecom, Reston, Virginia, is preferably used. The CODEC 54 also encodes audio and video data generated by the system 10 for transmission across a network to the remote videoconference site. Video data from the remote videoconference site 14 is provided to the projector 18 via a video transcoder (VID I/O) unit 56 and a scan doubler or enhanced definition encoder (EDC) 58. The EDC is preferably a model number EDC2000 manufactured by Yamashita Engineering Manufacture, Inc., Kanagawa, Japan. The transcoder 56 is preferably a model number VID I/O manufactured by TrueVision, Indianapolis, Indiana. The VID I/O unit 56 transcodes video to a composite format (Y/C) from a component format (RGB) in order to be supplied to the EDC 58. The EDC scan doubler enhances the video prior to projection. As will be discussed in further detail below, the EDC 58 also provides a full-screen preview of what is being transmitted to the remote videoconference site.

The projector is preferably a model number ECP3101 ACON projector available from Electrohome, Columbus, Ohio. This type of projector 18 is advantageous because it has advanced functionality such as ACON (automatic convergence), as well as computer control capability. The scan doubler 58 receives composite video from the camera 16 (e.g., a model number GP-US502 3CCD camera from Panasonic Broadcast and Television, Elgin, Illinois) via a digital video effects (DVE) module 60. The screen 20 used with projector 18 is preferably a single-layer, high gain, Fresnel-lenticular-type screen. For example, a 45 inch by eight inch Diamond Screen, available from Draper Screen Company, Spiceland, Indiana can be used. The projector is connected to a projector communications processor module

(CPM) 84, which provides remote projection control via the personal computer 70. The projector 18 can provide high-resolution graphic data from an external computer. Switching between projector sources is provided via the CPM 84.

5 Audio signals received from the remote videoconference site 14 are processed by the CODEC 54 and output to an audio mixer/amplifier unit 62. The audio mixer/amplifier unit 62 preferably comprises a model number 4800-series mixer 64 manufactured by Innovative Electronic Design (IED), Louisville, Kentucky, which mixes inputs from as many as 8 microphones into one signal. The audio mixer/amplifier unit 62 also comprises an IED model number 10 5000-Series Amplifier chassis 66 which holds cards for performing amplification and mixing, as well as echo cancellation. The audio mixer/amplifier unit 62 receives audio signals from the camera 16 and provides them to the CODEC 54 for transmission to the remote videoconference site 14. The audio system of the present invention 15 preferably uses JBL Control 1 speakers 24 and model numbers PCC-160 and PCC-160W Phase Coherent Cardioid, Crown microphones 22, both of which are available from Communications System Group, Covington, Kentucky. The audio system is provided with between one and four 20 microphones, although more can be used.

25 With continued reference to Fig. 2, the system 10 comprises a PLC chassis 68 (e.g, model number LittlePLC manufactured by Zworld Engineering, Davis, California) which encloses cards for controlling audio system volume and black and white balance functions of the camera, as well as other voltage controlled devices via a management 30 system described below. These functions are performed by a personal computer (PC) 70 via the PLC 68. The PC 70 is connected to a touch screen or other user interface 26 and

to the projector 18. The system 10 is configured to have a 16 x 9 aspect ratio and to provide full motion video at approximately 30 frames per second at all times. A management software control system is provided in the PC to control devices to perform such functions as providing via a picture-in-picture (PIP) display a preview of the local conference room scene that is to be transmitted, master input and output audio control, control of at least one external video source, simplified dialing for commencing communication with the remote videoconference site, automatic convergence, and switching between 16 X 9 and 4 X 3 video aspect ratios. The flat touch screen interfaces with the management system to receive user input. The system 10 can control external audio sources and video sources and perform switching among them.

The alternative embodiment of the invention, that is, system 10' depicted in Fig. 3, has a number of identical components such as the CSU 50, the IMUX 52, the CODEC 54, the audio mixer/amplifier unit 62, the touch screen 26, the PC 70, the PLC 68, and camera 16 interfaced with the CODEC 54 via a DVE 60. The roll-around model of system 10' comprises a monitor such as a PROSCAN 36 inch HDTV-formatted monitor 44 available from Thompson Consumer Electronics, Indianapolis, Indiana. The monitor 44 provides the projection and speaker systems for the roll-around embodiment of the system 10'.

As with the first embodiment of the system 10, the system 10' has 16 X 9 aspect ratio, full motion video, attempting 30 frames per second at all times. The management software control system for the videoconferencing system 10' also allows for control of at least one external video source and for simplified dialing to commence telecommunication with the remote conference site. The system 10' allows for master input audio

- 10 -

control. The system 10' provides for remote control of a number of functions such as PIP preview, television volume control, full screen preview, and aspect ratio switching.

5 The software control or management system for both the videoconferencing system 10 and system 10' is a software application which provides a user-friendly interface to conferees and other users so that they can control and manage the videoconferencing system 10 or 10'. Although the system is independent of whatever operating system it is run on, the management system is preferably used in connection with a Windows NT platform. UNIX and OS/2 operating systems can also be used. For program coding purposes, the management system is modeled as several separate layers, with each layer being responsible for its particular level of functionality within the management system. In addition to being modelled in a layered manner, the management system is designed using an object oriented-type approach wherein each layer in the model has several different objects. An object can represent a collection of methods used to control and manage a particular device such as the CODEC, a collection of devices such as the video components of the system 10, or a conceptual management model. The management system is designed to be quickly adapted to accommodate new devices added to the system 10 or 10', to comply with new international standards regarding, for example, telecommunications and high definition television, as well as to provide a software system that is relatively easily maintained.

#### 30 Infrared and Logic-Level Control Device

In accordance with a preferred embodiment of the present invention, an infrared (IR) and logic-level control device is provided to allow bidirectional serial control of devices in a videoconferencing system which have, for

example, a transistor-transistor logic level or TTL level, variable voltage-level or unidirectional, serial infrared control system. Thus, an infrared (IR) and logic-level control device can be provided in the system 10', for example, to allow for software control of IR-controllable components such as the monitor 44. The IR and logic-level control device can also be used, for example, in systems 10 and 10' to control peripheral devices such as a VCR 42 or a compact disc interactive player (CDI). The IR board can be substituted for the PLC 68 and perform the functions of the above-described PLC.

With reference to Fig. 4, the IR and logic-level control device is preferably implemented as a board and mounted into a rack-mountable cage, and shall hereinafter be referred to as the IR board. Figs. 5A and 5B are a schematic diagram of the IR board 86 constructed in accordance an embodiment of the present invention. With reference to Figs. 4 and 5A and 5B, the IR board 86 preferably comprises a microcontroller 90 and an RS-232 serial port 88 for communicating with the main control processor (not shown) of the PC 70. The microcontroller is connected to an erasable programmable read only memory (EPROM) circuit 94 via a latch 93 and to a random access memory (RAM) circuit 92. The microcontroller receives commands from the main control processor of the PC via its 9 pin D-type connector 88 and RS-232 interface 96. The commands are in accordance with an ASCII protocol. The microcontroller, in turn, transmits an acknowledgement signal (ACK) to the main control processor of the PC 70 and performs one or more functions in accordance with programmed code including, but not limited to: (1) transmitting IR control signals to a device in a videoconferencing system; (2) reading transistor-transistor logic-level or TTL level inputs from digital input ports;

- 12 -

(3) setting TTL states (e.g., high or low) for digital output ports; (4) transmitting variable voltage-level signals (e.g., from 0 to +5 volts DC) to analog output ports; and (5) performing on-board self-diagnostic functions.

5 In accordance with the present invention, the IR board 86 provides for remote control of a number of video and audio components in a videoconferencing system such as VCRs and televisions. For generating and transmitting serial IR control commands to a selected device (e.g., a VCR), the 10 microcontroller 90 generates a control command. The microcontroller can generate control commands for as many as eight serial IR outputs. It is to be understood that different numbers of serial IR outputs can be provided on 15 the IR board to control a larger or fewer number of devices in accordance with the invention. In accordance with the command inputs, the microcontroller generates output signals that are transmitted to the integrated circuits that need to be activated (e.g., a demultiplexer 100, a 20 latch 102 for TTL outputs, and digital-to-analog converters (DACs) 104 and 106). Each transmitted IR control command comprises two components supplied by the microcontroller: (1) a carrier frequency signal; and (2) a series of TTL pulses which represent the actual command information. 25 These two components are logically summed together via a an open-collector NAND gate for each output. The NAND gates are located on integrated circuits 108 and 110. The NAND gates in turn drive eight respective IR emitters indicated collectively at 112 and remotely located near a desired 30 receiver's window (e.g., the window of an IR-controllable VCR). The pulse width modulated IR signals are then received and decoded by the desired device, which translates the command information into its corresponding action(s) (e.g., rewind, pause, record).

- 13 -

The PC 70 via the IR board 86 can perform switching and otherwise remotely control a number of video and audio devices which can be controlled using TTL logic-level control signals or relay outputs. Such devices can include, for example, voltage-controlled audio systems, pan-tilt-zoom devices for video cameras and LED indicators. An octal latch 102 is connected to buffers 114 and 116, as well as to the decoder 98. The main processor of the PC 70 provides the microcontroller 90 with commands. The microcontroller 90 processes the commands and sets the logic-level of the appropriate output ports in response thereto. The TTL logic-level inputs are provided to the latch 102 when activated by the decoder 98. The inputs are then provided to the buffer 114 or 116, and then to respective ones of the output ports. The output ports are indicated generally at 118. At least two of them are relays.

Sometimes variable voltage-level analog signals are required to, for example, control the volume level of an audio system or to regulate the speed of miniature electric motors, as opposed to TTL logic-level signals. To provide variable analog control signals in accordance with the present invention, at least two DAC integrated circuits 104 and 106 and their associated hardware are connected to the microcontroller 90. In response to command signals from the main processor of the PC 70, the microcontroller sends input signals to a DAC, which performs conversion functions. The resulting voltage-level analog signals are sent to respective ones of the output ports, which are indicated collectively at 120 and are connected to voltage-level controlled devices.

In addition to providing different types of output signals with which to control devices in a videoconferencing system, the IR board is configured with

a feedback function for IR board diagnostics, and for devices which use TTL logic-level outputs for feedback purposes. The output signals from the DACs (e.g., output ports 120), the IR emitters 112, and the TTL logic-level output ports 118 are provided to multiplexers 122, 124 and 126, respectively. The multiplexer output signals are provided to the microcontroller 90, which runs a diagnostic program stored in the EPROM 94. The program evaluates the status of the IR board functions via the feedback signals of the circuits on the IR board and transmits status signals to the main processor of the PC 70.

As with IR board circuits, some devices in a videoconferencing system can provide feedback to the main processor of the PC 70 via the IR board 86, in accordance with the present invention. For example, TTL logic-level signals from external devices are provided to input ports, which are indicated generally at 128, and then to a multiplexer (e.g., an 8x1 multiplexer) 130.

The multiplexers 122, 124, 126 and 130 are connected to the microcontroller 90 via a unidirectional buffer 132. After selecting one of the multiplexers, one port on the microcontroller can service a plurality of input signals therefrom. For example, one port on the microcontroller 96 can service TTL logic-level inputs from as many as five external devices.

While the IR board 86 in Fig. 5 is depicted as comprising integrated circuits, the IR board of the present invention can be implemented other ways such as by using a programmable logic device (PLD) or an application-specific integrated circuit (ASIC). In addition, a port on the IR board can be configured to receive IR commands from a hand-held remote control which are then relayed to the main processor of the PC 70. Certain functions of the PC can therefore be controlled by the hand-held remote control.

- 15 -

Further, the program code for the IR board can allow the microcontroller to learn new IR command signals and therefore to control equipment from almost any manufacturer, regardless of IR command structure. Also, the IR board is useful as a system-level controller for desktop video editing systems or essentially any multimedia system comprising a number of devices that need to be controlled simultaneously.

### Videoconferencing Network

In accordance with another embodiment of the present invention, a network 140 is provided to support point-to-point or multi-point videoconferencing, and is particularly useful in conjunction with extensive use of multimedia applications. With reference to Fig. 6, the network 140 comprises a number of nodes 142 ( $n \geq 2$ ). Each node 142 preferably comprises two logically separate components: (1) a control and information transfer (CIT) terminal 144 which is responsible for overall control of the node itself and for managing information transferred to and from the node 142; and (2) an audio and video (AV) terminal 146 for processing audio and video data transferred to and from the node 142.

With continued reference to Fig. 6, the network 140 can be divided into a local-area network component indicated generally at 148 and a wide-area network component indicated generally at 150. The local area network component 148 comprises a number of nodes 142 in a common geographical area which are each connected to a common server via digital, analog or hybrid digital and analog communication links. A gateway node 152 is provided at the common point to operate as a gateway from the local area network component 148 to the wide area network component 150. The gateway node 152 comprises a

CODEC (not shown) and other communication facilities to operate in conjunction with a control server 154 and an AV server 156 translate signals between the local area network and wide area network components 148 and 150, respectively. The gateway is collocated with the AV server and the control server to seize analog lines and to perform routing between and among local nodes, as well as provide access to the wide area network component via the CODEC. The wide area network component 150 provides a communication link between stand-alone nodes and campus-wide networks containing multiple nodes or links multiple networks. The communications link can be implemented using a number of different types of network media, as described below.

The network 140 is advantageous because it can support group videoconferencing, and provide, in effect, a parallel networking structure for servicing both the AV terminal and CIT terminal located within each node. With regard to the control functions of a CIT terminal 142, a CIT terminal controls preferably all local functions pertaining to the node such as audio and video functions, as well as network control functions (e.g., AV terminal call set-up and tear-down and CIT terminal session connect and disconnect).

Regarding the information transfer functions of a CIT terminal 142, the CIT terminal can be used for any transfer of information for use during a videoconference, that is, non-real-time traffic such as compressed multimedia clips, application documents (e.g., spreadsheets) or graphics files. The CIT terminal can also be used for sharing files between or among nodal applications in near-real-time.

The AV terminal 144 is preferably used as a stand-alone processor for transmitting and receiving audio and

- 17 -

video data, e.g., a digital AV data stream formatted in accordance with the ITU/T H.320 suite of videoconferencing standards. In addition to interfacing with other AV terminals across the network, a AV terminal 144 decodes received audio and video data and presents it to the user, while encoding local audio and video data for transmission to one or more remote nodes. The CIT terminal controls preferably all of the functions of the AV terminal.

The use of parallel CIT and AV paths, an important principle of the network of the present invention, and the structure for each of the nodes 142 is similar, regardless of whether the node is part of a local area network (e.g., nodes 142a, 142b and 142c) or a stand-alone node in a wide area network (e.g., 142d). Options for connecting nodes, however, differ between the local area network component 148 and the wide area network component 150 of the network 140.

With regard to local-area connectivity, CIT connectivity is preferably provided by a conventional LAN connection (e.g., Ethernet, token ring or the like). This LAN connection can be either to an existing LAN, or to a separate LAN established for controlling a campus-type videoconferencing system comprising a number of nodes. The LAN for controlling a campus-type videoconferencing system can be connected via a bridge to an existing LAN to maintain centralized network management and resource availability. AV connectivity is preferably accomplished using high-speed digital communication lines (i.e., for compressed audio and video data) or full-bandwidth analog connections. The CIT terminal controls local area routing via the server hub (e.g., the control server and the AV server) in the gateway.

- 18 -

With regard to wide-area connectivity, CIT connectivity is preferably provided by two types of communications media: (1) a packet-switched network connection 158 for the control portion of the CIT terminal 144 to maintain essentially constant communication with other nodes (e.g., using the D channel of an ISDN line); and (2) a switched digital connection (e.g., ISDN, FT1) 160 for bandwidth-on-demand. The information transfer portion of a CIT terminal 144 is therefore allowed to accomplish out-of-band file transfers, file sharing and other data-related applications. For nodes operating on a fixed-bandwidth transmission platform such that no additional bandwidth is available upon demand, an in-band information transfer (IT) communications path is provided via optional H.320 time slot usage. AV connectivity, which is indicated generally at 162, can be provided by one of a number of high-speed digital communications methods such as ISDN, T1/E1 or satellite-based communications. The communication paths 158, 160 and 162 are preferably through public networks. The packet network therefore provides a single network connection that allows for dynamic bandwidth scalability for achieving higher quality of service.

The control packet network 158 connected to a CIT terminal provides a future upgrade path to higher-bandwidth, packet-based network services such as asynchronous transfer mode (e.g., ATM, FDDI and such) as upgraded paths become available or are implemented for widespread public use.

Fig. 7 provides an expanded view of two exemplary stand-alone nodes 142a and 142d. The node 142a comprises an AV terminal 146a which receives audio and video data from a number of microphones 170 and video devices (e.g.,

cameras) 172 via an audio switch 174 and a video switch 176. The audio and video data is provided to a CODEC 178 and an IMUX 180 for transmission to the other node 142d. The AV terminal 146d is also connected to output devices such as a projector 182 and a screen 184 via a video transceiver (e.g., a VID I/O unit) 186 and at least one speaker 188 via an amplifier 190. The AV terminal 142d is also connected to audio and video sources 170 and 172 for generating an AV data stream for transmission to the node 142a, as well as output devices (e.g., a projector 182, a screen 184 and a speaker 188) for the AV data stream received from the node 142a.

With continued reference to Fig. 6, a control data communication link 158 is provided in parallel with the audio/video communication link 162. The nodes 142a and 142d each preferably comprise a PC 196 connected to a monitor 198, one or more input devices such as a keyboard 200 and a mouse 202, and an optional printer 204 with scanning and facsimile functions. The CIT terminals 144a and 144d, respectively, are connected to the AV terminals 146a and 146d, respectively, for controlling local audio and video functions, as well as performing other nodal functions such as network control functions. The CIT terminal of each node is connected to the control data communications link 158 via a communications interface 206.

The CIT terminals can optionally be connected by another parallel communication link, that is, the information transfer communication link 160 indicated by the phantom communication line in Fig. 7, as needed if out-of-bandwidth file sharing, file transfer or another data-related application involving the nodes 142a and 142d is desired. Alternatively, if one of the nodes has a fixed-bandwidth transmission platform, and no

additional bandwidth is available on demand, an H.320 bit stuffing operation on the AV communication link 162 can be used as an in-band IT communications path.

5 The packet-switched control data communications link 158 is advantageous because it provides common-channel control and signaling, among other reasons. As stated previously, the common-channel connection permits the establishment of dual-mode data communications, that is, in-band and optional out-of-band communications. The  
10 common-channel connection therefore can be used to establish additional bandwidth on a temporary basis for graphics and file transfer, among other data-related applications. The common-channel connection also assists two nodes in establishing a conference through CIT  
15 terminal communication.

The packet-switched control data communications link 158 is also advantageous because one node can identify the capabilities (e.g., whether or not additional bandwidth is available on demand) of another node via  
20 node identification. In addition, videoconferencing systems can maintain their own schedules of availability, which can be accessed by nodes to ascertain when a videoconference can be established with that node. The packet network increases ease of access, as an ISDN D  
25 channel can provide a 9600 baud, ongoing connection to the packet network for connecting a number of videoconferencing systems to the same network. Finally, security is improved since each node is validated by a central server; otherwise, the node does not function in  
30 the packet network.

While certain advantageous embodiments have been chosen to illustrate the invention, it will be understood by those skilled in the art that various changes and modifications can be made herein without departing from

the scope of the invention as defined in the appended claims.

What Is Claimed Is

1. A videoconferencing system, comprising:

a processor;

at least one of a plurality of devices connected to  
5 said processor comprising an audio device and a video  
device, said device being controlled in accordance with  
at least one of a plurality of signal types comprising  
transistor-transistor logic-level signals, serial  
infrared signals and analog control signals;

10 a control circuit connected to said processor, said  
processor being programmable to generate a command signal  
and provide said command signal to said control circuit,  
said control circuit being configured to process said  
command signal and to generate an output control signal  
15 in accordance with said command signal for transmission  
to said device and being at least one of said plurality  
of signal types that is compatible with said device.

2. A videoconferencing system as claimed in claim 1,  
20 wherein said control circuit comprises a second processor  
configured to communicate with said processor via a  
serial communication link.

3. A videoconferencing system as claimed in claim 1,  
25 wherein said control circuit comprises an input port  
connected to said device, said device being operable to  
provide said processor with a status signal indicating  
operating conditions of said device.

4. A videoconferencing system, comprising:

a processor;

at least one of a plurality of devices connected to  
30 said processor comprising an audio device and a video  
device;

- 23 -

a control circuit connected to said processor, said processor being programmable to generate a command signal and provide said command signal to said control circuit;

5 wherein said device comprises an infrared receiver, said control circuit comprises at least one infrared emitter optically coupled to said infrared receiver and a second processor configured to process said command signal and generate an output signal comprising pulses corresponding to said command signal, said control  
10 circuit being operable to generate a carrier frequency signal, to logically combine said output signal with said carrier frequency signal and to transmit said combined signal to said infrared emitter.

15 5. A videoconferencing system as claimed in claim 4, wherein said control circuit is configured to provide said output signal to said second processor for feedback.

20 6. A videoconferencing system, comprising:

a processor;

at least one of a plurality of devices connected to said processor comprising an audio device and a video device;

25 a control circuit connected to said processor, said processor being programmable to generate a command signal and provide said command signal to said control circuit;

30 wherein said device comprises an input port, said control circuit comprises a second processor configured to process said command signal and generate an output signal comprising a transistor-transistor logic-level signal corresponding to said command signal, said control circuit being operable to transmit said output signal to said input port.

7. A videoconferencing system as claimed in claim 6, wherein said control circuit is configured to provide said output signal to said second processor for feedback.

5 8. A videoconferencing system, comprising:  
a processor;

at least one of a plurality of devices connected to said processor comprising an audio device and a video device;

10 a control circuit connected to said processor, said processor being programmable to generate a command signal and provide said command signal to said control circuit;

15 wherein said device comprises an input port, said control circuit comprises a second processor configured to process said command signal and generate an output signal comprising a variable-voltage level signal corresponding to said command signal, said control circuit being operable to transmit said output signal to said input port.

20 9. A videoconferencing system as claimed in claim 8, wherein said control circuit is configured to provide said output signal to said second processor for feedback.

25 10. A method of controlling audio and video devices in a videoconferencing system comprising the steps of:

receiving a command signal for controlling a selected one of said audio and video devices;

30 generating a control signal in accordance with said command signal, said control signal being selected from a group of signals consisting of logic-level signals, serial infrared signals and analog control signals so as to be compatible with said selected one of said audio and video devices; and

transmitting said control signal to said selected one of said audio and video devices.

5 11. A method as claimed in claim 10, wherein said control signal is a serial infrared signal comprising a carrier frequency signal and a series of logic-level pulses representing command data in said command signal, and said transmitting step comprises the step of providing said control signal to an infrared emitter.

10 12. A method as claimed in claim 10, further comprising the steps of:

receiving said control signal at said selected one of said audio and video devices; and

15 decoding said control signal into an action to be performed by said selected one of said audio and video devices.

20 13. A videoconferencing system, comprising:

first and second nodes each having at least one audio input device, at least one video input device, at least one audio output device, at least one video output device and a processor, said second node being operable to receive audio and video data generated by said audio input device and said video input device of said first node and to transmit to said first node audio and video data generated by said audio input device and said video input device of said second node;

30 an audio and video data communication link connected to said first node and to said second node; and

a control data communication link connected to said first node and to said second node and operable in parallel with said audio and video data communication link;

- 26 -

said processor of said first node being programmable to transmit audio and video data generated by corresponding said audio input device and said video input device to said second node on said audio and video data communication link, and to generate and transmit control data to said second node on said control data communication link;

said processor of said second node being programmable to transmit audio and video data generated by corresponding said audio input device and said video input device to said first node on said audio and video data communication link, and to generate and transmit control data to said first node on said control data communication link.

14. A videoconferencing system as claimed in claim 13, wherein said control data communications link is a packet switched network.

15. A videoconferencing system as claimed in claim 13, wherein said audio and video communications link is a high speed serial digital communications link.

16. A videoconferencing system as claimed in claim 13, further comprising a third node, a local area network having an audio and video communication path and a separate and parallel control data communication path, a control server and an audio and video server, said audio and video server and said control server being operable to connect said third node to said first node via said audio and video communication path and said control data communication path, respectively.

- 27 -

17. A videoconferencing system as claimed in claim 16,  
further comprising a gateway node, said local area  
network being connected to said audio and video  
communication link and said control data communication  
links via said gateway node.

18. A videoconferencing system as claimed in claim 13,  
further comprising:

at least one data input device connected to said  
first node for generating data to be transmitted to said  
second node during a videoconference; and

an information transfer communication link connected  
to said first node and to said second node and operable  
in parallel with respect to said control data  
communication link, said processor in said first node  
being programmable to transmit said data generated by  
said data input device to said second node outside the  
bandwidth of said audio and video data during a  
videoconference via said information transfer  
communication link.

19. A videoconferencing system as claimed in claim 18,  
wherein said audio and video communication link is  
configured to transmit control bits which can be used in  
a bit stuffing operation to transfer said data along said  
audio and video communication link using at least a  
portion of the bandwidth of said audio and video data.

20. A method of networking a first node and a second  
node in a videoconferencing system, comprising the steps  
of:

transmitting audio and video data for a  
videoconference between said first node and said second  
node along a first communication path in a network; and  
transmitting control data for establishing said  
5 videoconference and managing said network along a second  
communication path that is parallel to said first  
communication path.

21. A method as claimed in claim 20, further comprising  
10 the steps of:

connecting said first node and said second node to a  
gateway node; and

15 connecting said gateway node to a third node via  
first and second communication links, said third node  
being operable to transmit and receive audio and video  
data on said first communication link, and to transmit  
and receive control data along said second communication  
link.

22. A method as claimed in claim 21, wherein said first  
20 communication link is a high speed serial digital  
communications link.

23. A method as claimed in claim 21, wherein said second  
25 communication link is a packet switched network.

**AMENDED CLAIMS**

[received by the International Bureau on 02 October 1996 (02.10.96);  
original claims 1 and 6 amended;  
remaining claims unchanged (2 pages)]

1. A videoconferencing system, comprising:

a processor;

at least one of a plurality of devices connected to  
said processor comprising an audio device and a video  
device, said device being controlled in accordance with at  
least one of a plurality of signal types comprising  
discrete logic-level signals, serial infrared signals and  
analog control signals;

a control circuit connected to said processor, said  
processor being programmable to generate a command signal  
and provide said command signal to said control circuit,  
said control circuit being configured to process said  
command signal and to generate an output control signal in  
accordance with said command signal for transmission to  
said device and being at least one of said plurality of  
signal types that is compatible with said device.

2. A videoconferencing system as claimed in claim 1,  
wherein said control circuit comprises a second processor  
configured to communicate with said processor via a serial  
communication link.

3. A videoconferencing system as claimed in claim 1,  
wherein said control circuit comprises an input port  
connected to said device, said device being operable to  
provide said processor with a status signal indicating  
operating conditions of said device.

4. A videoconferencing system, comprising:

a processor;

at least one of a plurality of devices connected to  
said processor comprising an audio device and a video  
device;

a control circuit connected to said processor, said processor being programmable to generate a command signal and provide said command signal to said control circuit;

5 wherein said device comprises an infrared receiver, said control circuit comprises at least one infrared emitter optically coupled to said infrared receiver and a second processor configured to process said command signal and generate an output signal comprising pulses corresponding to said command signal, said control circuit  
10 being operable to generate a carrier frequency signal, to logically combine said output signal with said carrier frequency signal and to transmit said combined signal to said infrared emitter.

15 5. A videoconferencing system as claimed in claim 4, wherein said control circuit is configured to provide said output signal to said second processor for feedback.

20 6. A videoconferencing system, comprising:

a processor;

at least one of a plurality of devices connected to said processor comprising an audio device and a video device;

25 a control circuit connected to said processor, said processor being programmable to generate a command signal and provide said command signal to said control circuit;

30 wherein said device comprises an input port, said control circuit comprises a second processor configured to process said command signal and generate an output signal comprising a discrete logic-level signal corresponding to said command signal, said control circuit being operable to transmit said output signal to said input port.

FIG. 1

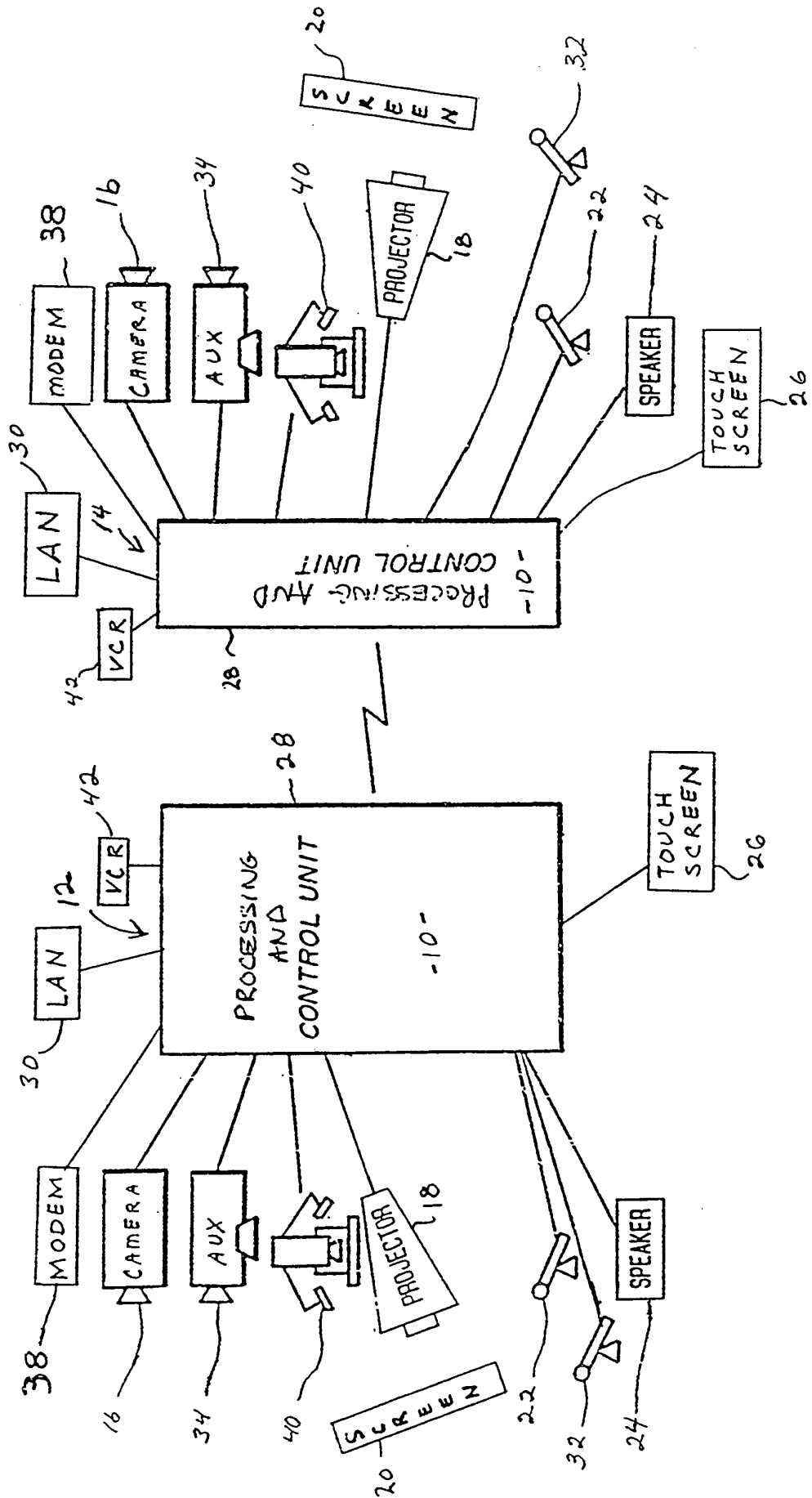

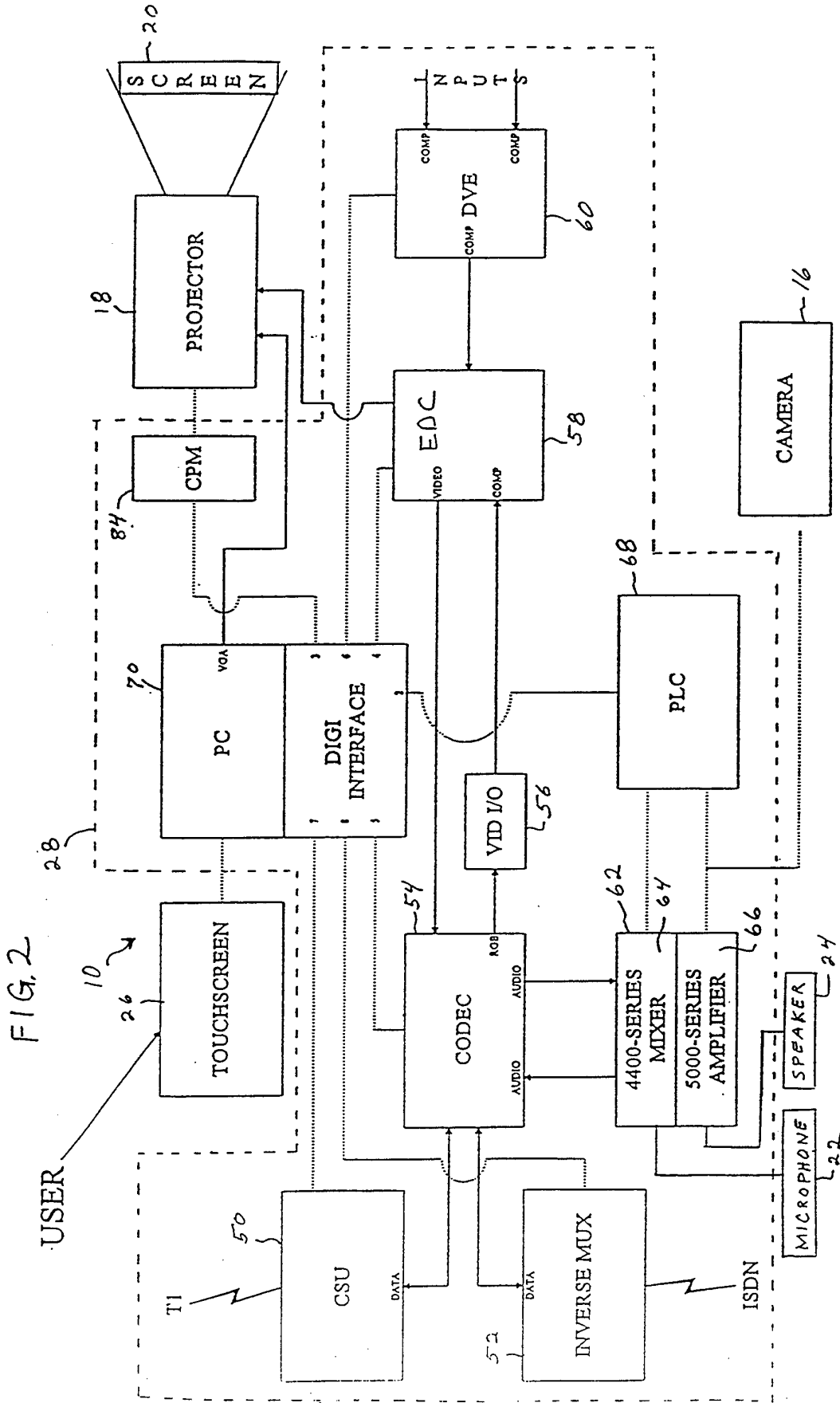

FIG. 3

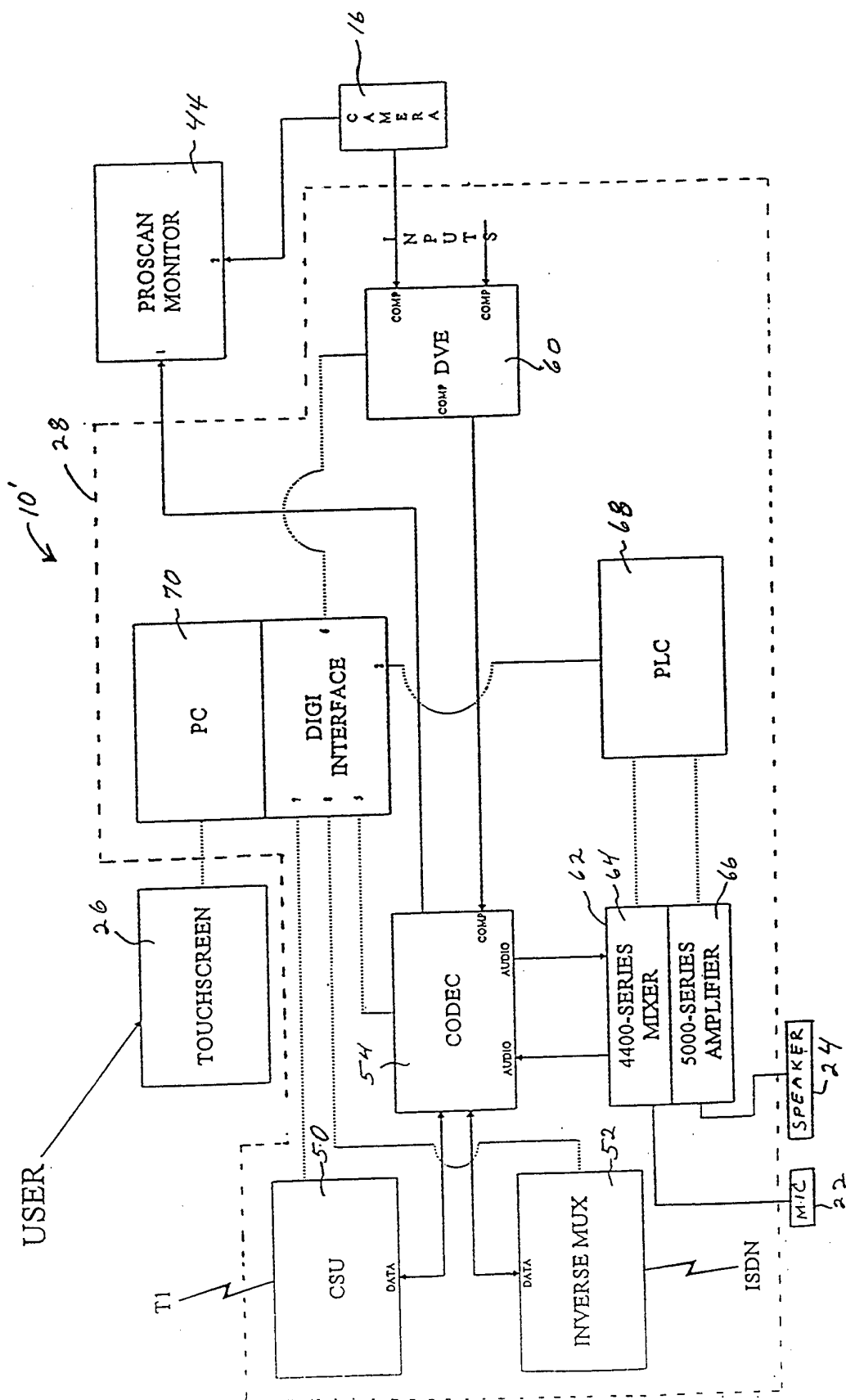

FIG. 4

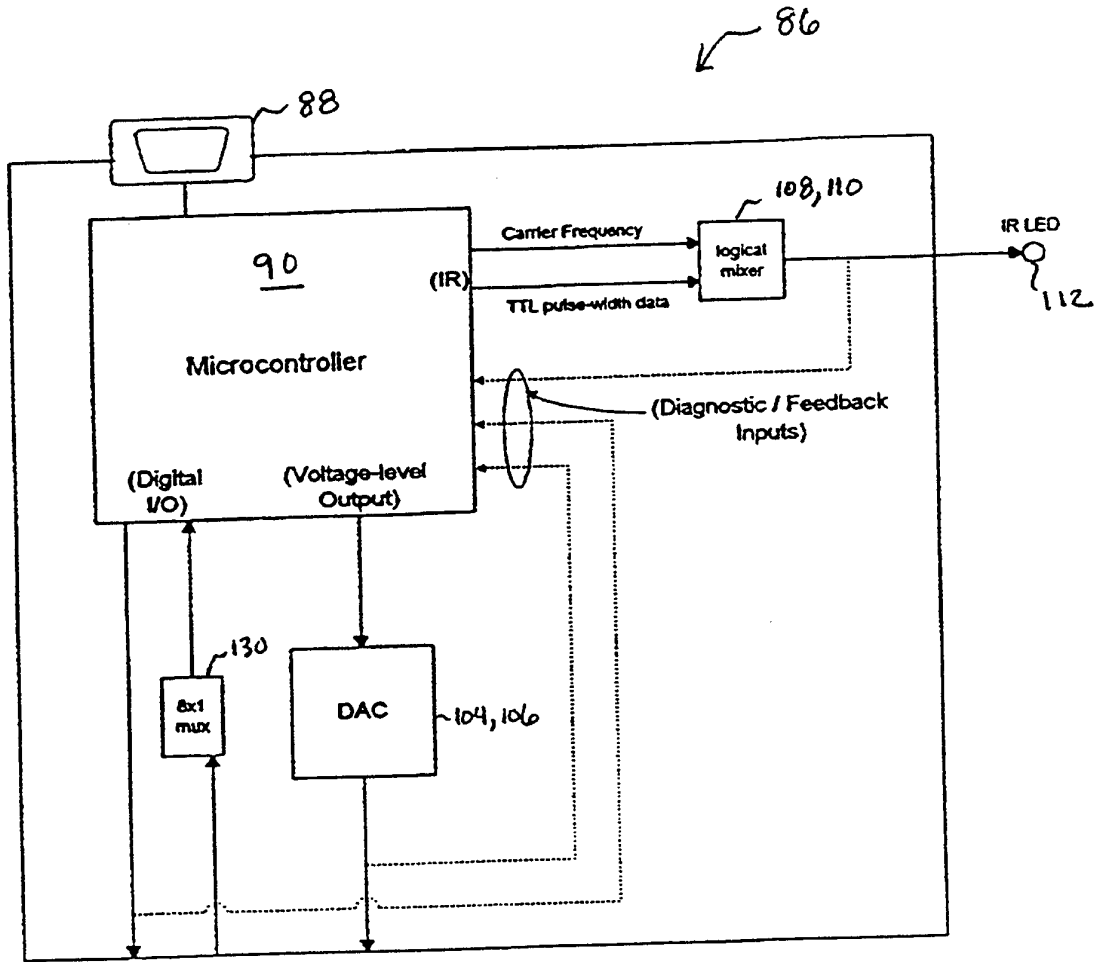
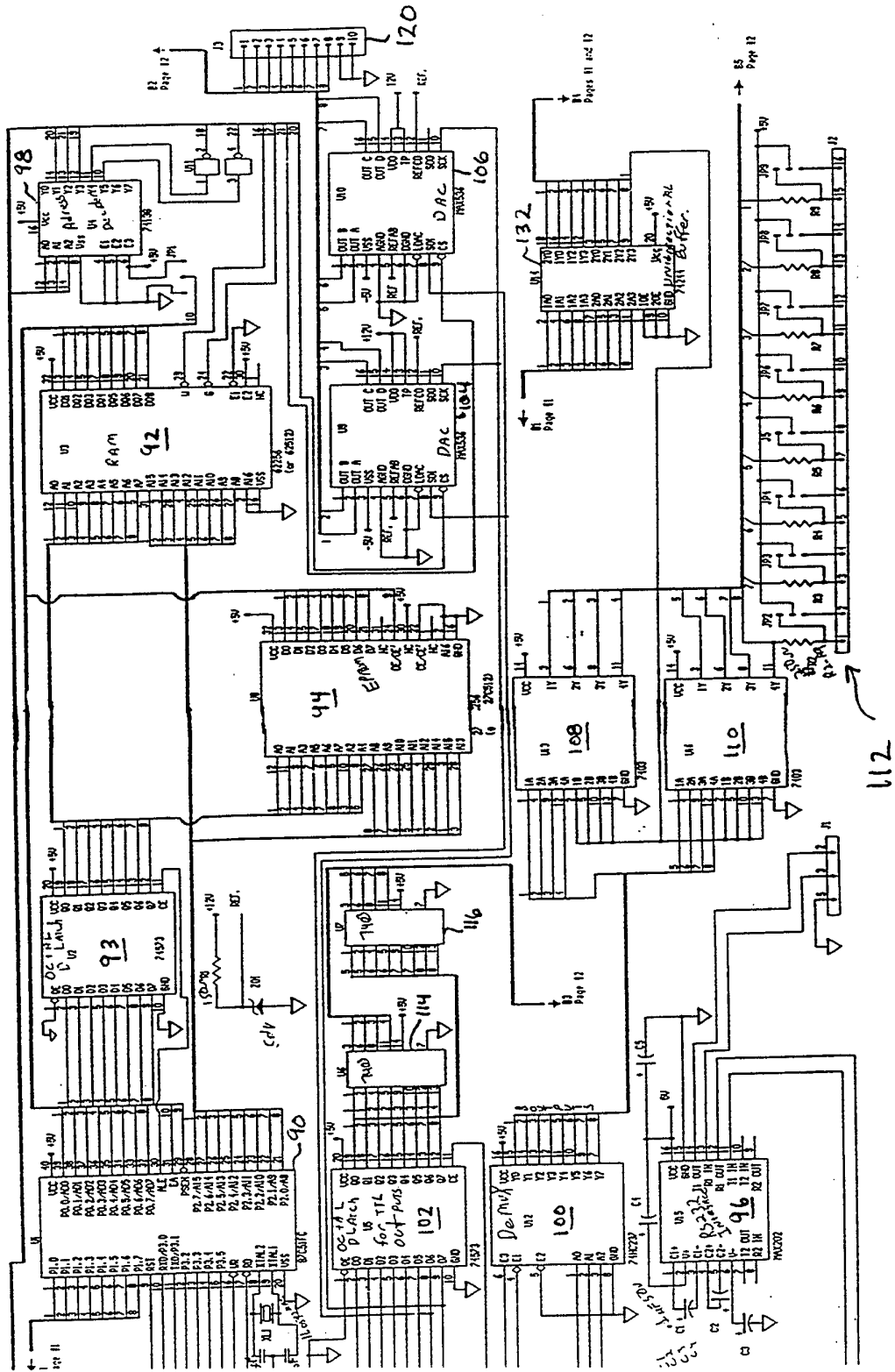
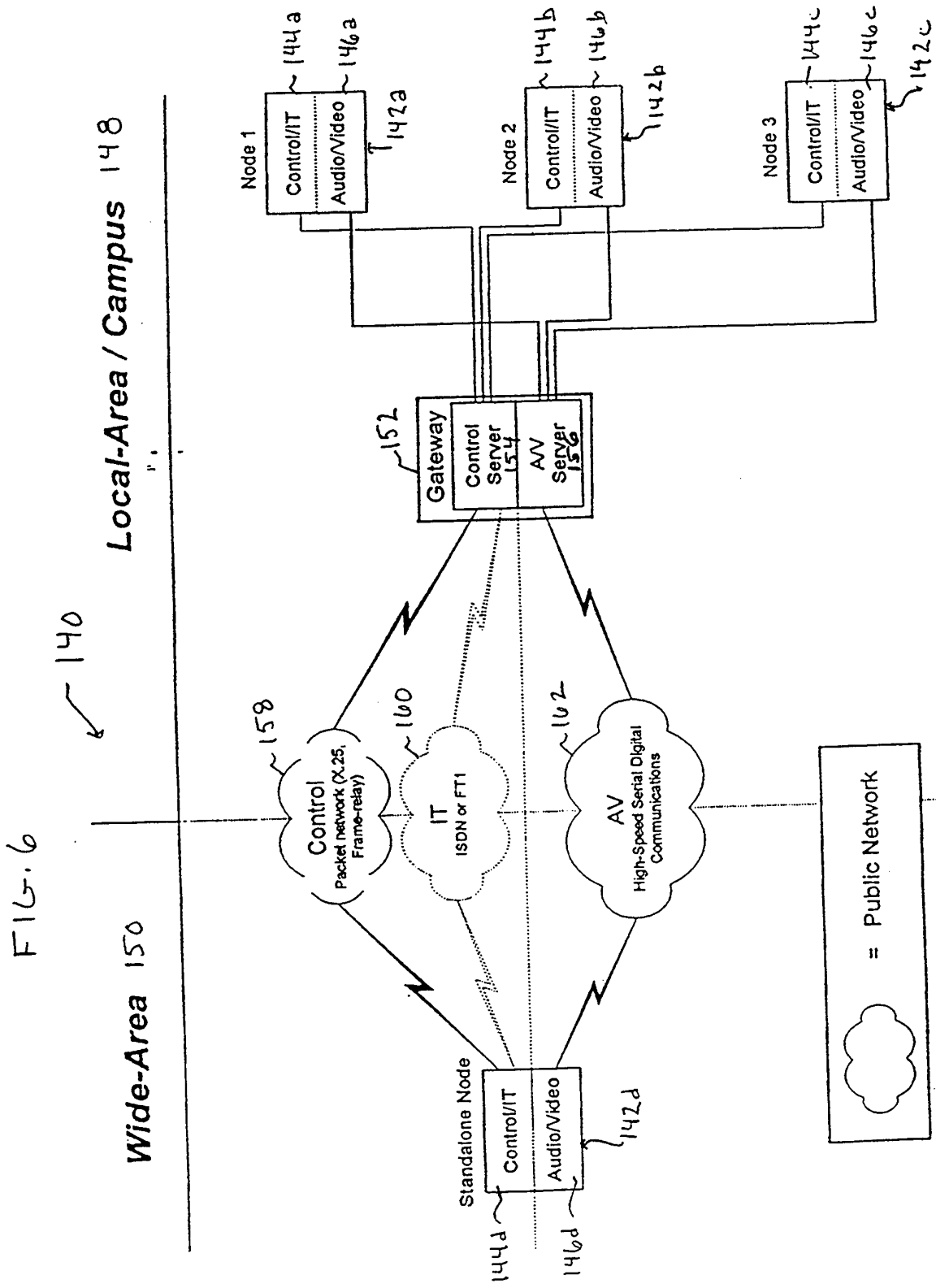

FIG. 5A

86









INTERNATIONAL SEARCH REPORT

International application No.  
PCT/US96/10017

A. CLASSIFICATION OF SUBJECT MATTER

IPC(6) :H04N 07/14; H04N 05/44; H04M 11/00; H04M 03/42  
US CL :348/13-19, 734; 379/93, 94, 96, 102-105, 202; 370/62

According to International Patent Classification (IPC) or to both national classification and IPC

B. FIELDS SEARCHED

Minimum documentation searched (classification system followed by classification symbols)

U.S. : 348/13-19, 734; 379/93, 94, 96, 102-105, 202; 370/62

Documentation searched other than minimum documentation to the extent that such documents are included in the fields searched

NONE

Electronic data base consulted during the international search (name of data base and, where practicable, search terms used)

Please See Extra Sheet.

C. DOCUMENTS CONSIDERED TO BE RELEVANT

Category*	Citation of document, with indication, where appropriate, of the relevant passages	Relevant to claim No.
X ----- Y	US, A, 4,882,747 (WILLIAMS) 21 November 1989, see the whole document.	1, 3, 10-12 ----- 2, 4-9
Y	US, A, 5,283,638 (ENGBERG ET AL) 01 February 1994, col. 6, lines 41-44 and col. 12, lines 4-18.	1-12
X ----- Y	US, A, 5,371,534 (DAGDEVIREN ET AL) 06 December, 1994, col. 6, lines 20-22, col. 9, lines 18-21 and Fig. 2.	13, 15, 20 ----- 14, 16-19, 21-23

Further documents are listed in the continuation of Box C.  See patent family annex.

* Special categories of cited documents:	*T* later document published after the international filing date or priority date and not in conflict with the application but cited to understand the principle or theory underlying the invention
*A* document defining the general state of the art which is not considered to be part of particular relevance	*X* document of particular relevance; the claimed invention cannot be considered novel or cannot be considered to involve an inventive step when the document is taken alone
*E* earlier document published on or after the international filing date	*Y* document of particular relevance; the claimed invention cannot be considered to involve an inventive step when the document is combined with one or more other such documents, such combination being obvious to a person skilled in the art
*L* document which may throw doubts on priority claim(s) or which is cited to establish the publication date of another citation or other special reason. (as specified)	*G* document member of the same patent family
*O* document referring to an oral disclosure, use, exhibition or other means	
*P* document published prior to the international filing date but later than the priority date claimed	

Date of the actual completion of the international search

08 AUGUST 1996

Date of mailing of the international search report

27 AUG 1996

Name and mailing address of the ISA/US  
Commissioner of Patents and Trademarks  
Box PCT  
Washington, D.C. 20231

Facsimile No. (703) 305-3230

Authorized officer

*Jason Chan*  
JASON CHAN

Telephone No. (703) 305-4700

# INTERNATIONAL SEARCH REPORT

International application No.  
PCT/US96/10017

## Box I Observations where certain claims were found unsearchable (Continuation of item 1 of first sheet)

This international report has not been established in respect of certain claims under Article 17(2)(a) for the following reasons:

1.  Claims Nos.:  
because they relate to subject matter not required to be searched by this Authority, namely:
  
2.  Claims Nos.:  
because they relate to parts of the international application that do not comply with the prescribed requirements to such an extent that no meaningful international search can be carried out, specifically:
  
3.  Claims Nos.:  
because they are dependent claims and are not drafted in accordance with the second and third sentences of Rule 6.4(a).

## Box II Observations where unity of invention is lacking (Continuation of item 2 of first sheet)

This International Searching Authority found multiple inventions in this international application, as follows:

Please See Extra Sheet.

1.  As all required additional search fees were timely paid by the applicant, this international search report covers all searchable claims.
2.  As all searchable claims could be searched without effort justifying an additional fee, this Authority did not invite payment of any additional fee.
3.  As only some of the required additional search fees were timely paid by the applicant, this international search report covers only those claims for which fees were paid, specifically claims Nos.:
  
4.  No required additional search fees were timely paid by the applicant. Consequently, this international search report is restricted to the invention first mentioned in the claims; it is covered by claims Nos.:

Remark on Protest

The additional search fees were accompanied by the applicant's protest.

No protest accompanied the payment of additional search fees.

## INTERNATIONAL SEARCH REPORT

International application No.  
PCT/US96/10017

C (Continuation). DOCUMENTS CONSIDERED TO BE RELEVANT		
Category*	Citation of document, with indication, where appropriate, of the relevant passages	Relevant to claim No.
X	WO 94/24804 (AHUJA ET AL) 27 October 1994, see the whole document.	13-23

# INTERNATIONAL SEARCH REPORT

International application No.

PCT/US96/10017

## B. FIELDS SEARCHED

Electronic data bases consulted (Name of data base and where practicable terms used):

APS, search terms: remote control, remote controller, conference, videoconference, IR, infrared, infrared emitter, infrared receiver, ISDN, high speed serial digital link, packet switched network, T1, gateway, nodes, D channel, B channel.

## BOX II. OBSERVATIONS WHERE UNITY OF INVENTION WAS LACKING

This ISA found multiple inventions as follows:

1. Group I, claim(s) 1-12, drawn to a control device for videoconferencing.

Group II, claim(s) 13-23, drawn to a method for transmitting data between communication nodes in a videoconferencing system.

2. The inventions listed as Groups I and II do not relate to a single inventive concept under PCT Rule 13.1 because, under PCT Rule 13.2, they lack the same or corresponding special technical features for the following reasons: the control device features recited in Group I is not required in the transmission method as recited in Group II.

Therefore, Groups I and II lack the same or corresponding special technical features.