

1 559 975

- (21) Application No. 43621/75 (22) Filed 23 Oct. 1975 (19)
- (23) Complete Specification filed 14 Oct. 1976
- (44) Complete Specification published 30 Jan. 1980
- (51) INT. CL.<sup>3</sup> B60T 11/34
- (52) Index at acceptance  
F2F 761 772 DC
- (72) Inventor GRAHAM JOHN GORNALL



(54) IMPROVEMENTS IN OR RELATING TO LOAD-CONSCIOUS CONTROL VALVE ASSEMBLIES

(71) We, GIRLING LIMITED, a British Company, of Kings Road, Tyseley, Birmingham 11, do hereby declare the invention, for which we pray that a patent may be granted to us, and the method by which it is to be performed, to be particularly described in and by the following statement:—

This invention relates to load-conscious control valve assemblies for use in vehicle braking systems.

A previously proposed control valve assembly comprises a normally-open control valve having a housing, an inlet and an outlet in the housing, and a valve member movable against a pre-load to close the valve in response to inlet pressure, and pre-loading means which subjects the valve to said pre-load, said pre-loading means comprising a pivotally mounted lever and means biasing the lever into engagement with the valve member.

Such a valve is normally inserted between the pressure source of the braking system, for example a master cylinder, and one or more brakes, usually the rear brakes. The valve may be a pressure limiting valve or a pressure reducing valve which limits or reduces the pressure applied to the rear brakes as compared to the pressure applied to the front brakes.

The previously proposed valve has the disadvantage that, in the event of failure of the spring, the lever can move about its pivot and permit uncontrolled movement of the valve member, which may cause damage to the valve member or the seat with which it co-operates to open and close the valve.

The present invention aims to overcome the above-mentioned disadvantages and provides a load-conscious control valve assembly comprising a housing having an inlet and an outlet for connection in a pressure line of a braking system, a valve controlling communication between the inlet and outlet and comprising an apertured valve seat and a valve member which extends through the valve seat and has a valve head rearwardly

of the valve seat and engageable therewith to close the valve, the valve member extending forwardly of the valve seat and projecting from the housing, and pre-loading means biasing the valve member rearwardly to normally hold the valve open, said pre-loading means comprising a lever biased into engagement with the valve member and having at one end at least two arms which extend away from each other, one of the arms being bent to receive a pin which is secured to the housing and on which the lever can pivot and the other arm extending rearwardly and being engageable with a stop integral or otherwise fast with the housing to limit pivotal movement of the lever.

A valve control assembly in accordance with the invention for a vehicle braking system will now be described, by way of example, with reference to the accompanying drawings, in which:—

Figure 1 is an axial cross-section of the valve assembly, including pre-loading means, and

Figure 2 is an end view of the assembly of Figure 1.

The assembly of Figure 1 includes a control valve 1 comprising a housing 2 having a stepped bore 3 into which opens an inlet 4 and outlet 5. Contained within the bore is an annular insert 6 which is retained by a circlip 16 and slidably supports a valve member 7 having a valve head 8. The valve head 8 is engageable with an annular valve seat 9 held against a shoulder 11 of the bore by a spring 12 acting between the valve seat and a seal 13 engaging one end of the insert 6. The valve seat 9 also acts as a dividing wall separating the inlet 4 and outlet 5.

In the illustrated control valve 1, the valve member 7 extends from the housing and engages a pre-loading means comprising lever 17 pivotally mounted at one end on a bolt 18 which extends between lugs 19 on the valve housing 2.

In normal use, the valve housing 2 is mounted on a sprung part of the vehicle by

5  
10  
15  
20  
25  
30  
35  
40  
45

50  
55  
60  
65  
70  
75  
80  
85  
90

means of the bolt 18 and a tension spring 21 connects the lever 17 to an unsprung part of the vehicle, for example the rear axle, so that relative movement of the sprung and unsprung parts of the vehicle, which occurs for example when the vehicle is loaded, will vary the tension in the spring 21 and thus the pre-load transmitted by the lever 19 and acting on the valve member 7. The inlet 5 leads to a fluid pressure source, such as a master cylinder, and the outlet leads to one or more wheel brakes, usually the rear brakes.

The upper end of lever 17 has three arms, two of which, 17A, are bent into a generally hook-shaped cross-section and snugly receive the bolt 18. The other arm 17B is located between and is bent away from the other arms 17A and is normally close to but spaced from a stop formed by a projection 20 on housing 1.

The operation of the valve is as follows. When the brakes are applied pressure fluid is fed through the normally-open valve through the outlet to the brake. The pressure acts on the valve member 7 over an area equivalent to the cross-sectional area of the portion of the valve member 7 passing through the insert 5 and when the pressure force on the valve member exceeds the pre-load the valve member moves to the left and the valve head 8 engages the seat 9 to close the valve.

Thus, any further increase in pressure at the inlet is not transferred to the outlet.

When the inlet pressure is released the valve member moves to the right to open the valve when the pressure force is reduced to a value below the pre-load.

In the event of failure of the spring pivotal movement of the lever 17 in a direction permitting closure of the valve is limited by the engagement of arm 17B with the projection 20. The spacing between the arm 17B and the stop 20 is such that the valve head 8 is permitted to engage valve seat 9 to close the valve but cannot travel excessively to the left or damage the valve seat. Furthermore the lever 17 cannot drop off its pivot pin and the closure member cannot fall out.

WHAT WE CLAIM IS:—

1. A load-conscious control valve as-

sembly comprising a housing having an inlet and an outlet for connection in a pressure line of a braking system, a valve controlling communication between the inlet and outlet and comprising an apertured valve seat and a valve member which extends through the valve seat and has a valve head rearwardly of the valve seat and engageable therewith to close the valve, the valve member extending forwardly of the valve seat and projecting from the housing, and pre-loading means biasing the valve member rearwardly to normally hold the valve open, said pre-loading means comprising a lever biased into engagement with the valve member and having at one end at least two arms which extend away from each other, one of the arms being bent to receive a pin which is secured to the housing and on which the lever can pivot and the other arm extending rearwardly and being engageable with a stop integral or otherwise fast with the housing to limit pivotal movement of the lever.

2. A valve assembly according to claim 1, wherein the arm which receives the pin is one of two such arms which are spaced apart and are located one on each side of the rearwardly extending arm.

3. A valve assembly according to claim 1 or 2, wherein the spacing between the rearwardly extending arm and the stop is sufficient to permit the head of the valve member to engage the valve seat but to prevent the valve head passing through the aperture in the valve seat.

4. A valve assembly according to any of the preceding claims, wherein the rearwardly extending arm of the lever is integral with the lever.

5. A valve assembly constructed and arranged to operate substantially as herein described with reference to the accompanying drawings.

A. A. THORNTON & CO.,  
Chartered Patent Agents,  
Northumberland House,  
303/306 High Holborn,  
London, WC1V 7LE.

This drawing is a reproduction of the Original on a reduced scale

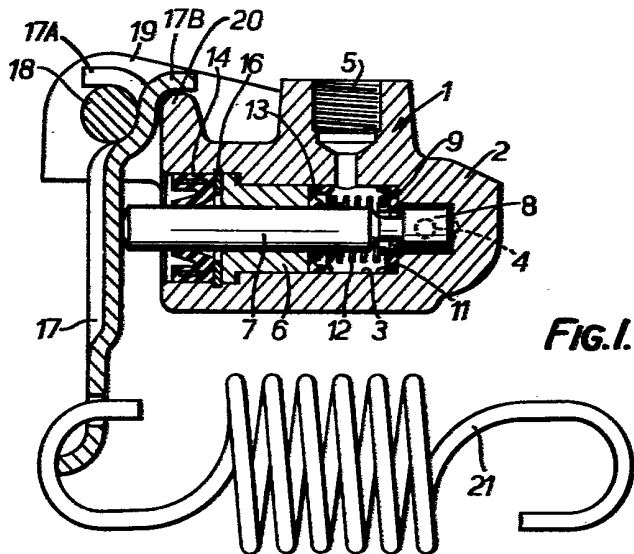

FIG. 1.

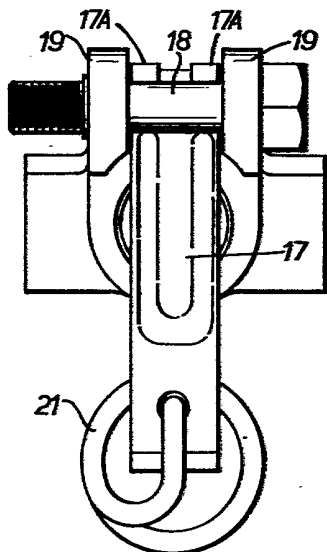

FIG. 2.