

(19) World Intellectual Property Organization
International Bureau



(43) International Publication Date
4 July 2002 (04.07.2002)

PCT

(10) International Publication Number
WO 02/051462 A2

(51) International Patent Classification⁷: A61L 27/00

(21) International Application Number: PCT/US01/47341

(22) International Filing Date: 6 December 2001 (06.12.2001)

(25) Filing Language: English

(26) Publication Language: English

(30) Priority Data:
09/752,212 27 December 2000 (27.12.2000) US

(71) Applicant: **ADVANCED CARDIOVASCULAR SYSTEMS, INC.** [US/US]; 3200 Lakeside Drive, Santa Clara, CA 95054-2807 (US).

(81) Designated States (*national*): AE, AG, AL, AM, AT, AU, AZ, BA, BB, BG, BR, BY, BZ, CA, CH, CN, CO, CR, CU, CZ, DE, DK, DM, DZ, EC, EE, ES, FI, GB, GD, GE, GH, GM, HR, HU, ID, IL, IN, IS, JP, KE, KG, KP, KR, KZ, LC, LK, LR, LS, LT, LU, LV, MA, MD, MG, MK, MN, MW, MX, MZ, NO, NZ, OM, PH, PL, PT, RO, RU, SD, SE, SG, SI, SK, SL, TJ, TM, TR, TT, TZ, UA, UG, UZ, VN, YU, ZA, ZM, ZW.

(84) Designated States (*regional*): ARIPO patent (GH, GM, KE, LS, MW, MZ, SD, SL, SZ, TZ, UG, ZM, ZW), Eurasian patent (AM, AZ, BY, KG, KZ, MD, RU, TJ, TM), European patent (AT, BE, CH, CY, DE, DK, ES, FI, FR, GB, GR, IE, IT, LU, MC, NL, PT, SE, TR), OAPI patent (BF, BJ, CF, CG, CI, CM, GA, GN, GQ, GW, ML, MR, NE, SN, TD, TG).

(72) Inventors: **BOYLAN, John, F.**; 37896 Sky High Drive, Murrieta, CA 92562 (US). **COX, Daniel, L.**; 191 Washington Avenue, Palo Alto, CA 94301 (US).

Published:
— without international search report and to be republished upon receipt of that report

(74) Agents: **HANKE, Gunther, O.** et al.; Fulwider Patton Lee & Utecht, LLP, Howard Hughes Center, 6060 Center Drive, Tenth Floor, Los Angeles, CA 90045 (US).

For two-letter codes and other abbreviations, refer to the "Guidance Notes on Codes and Abbreviations" appearing at the beginning of each regular issue of the PCT Gazette.

(54) Title: RADIOPAQUE NITINOL ALLOYS FOR MEDICAL DEVICES

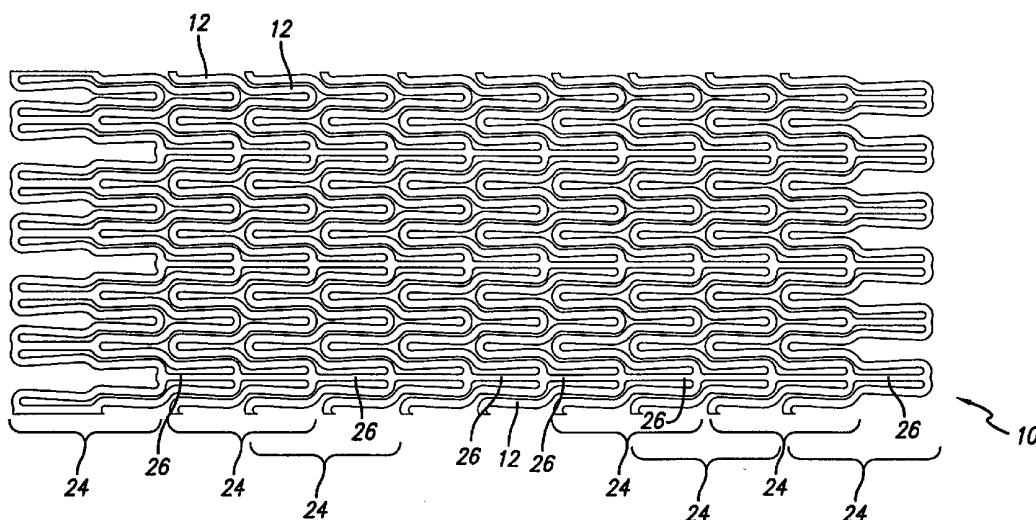

(57) **Abstract:** A radiopaque nitinol medical device such as a stent for use with or implantation in a body lumen is disclosed. The stent is made from a superelastic alloy such as nickel-titanium or nitinol, and includes a ternary element selected from the group of chemical elements consisting of iridium, platinum, gold, rhenium, tungsten, palladium, rhodium, tantalum, silver, ruthenium, or hafnium. The added ternary element improves the radiopacity of the nitinol stent comparable to that of a stainless steel stent of the same size and strut pattern coated with a thin layer of gold. The nitinol stent has improved radiopacity yet retains its superelastic and shape memory behavior and further maintains a thin strut/wall thickness for high flexibility.



WO 02/051462 A2

RADIOPAQUE NITINOL ALLOYS FOR MEDICAL DEVICES

BACKGROUND OF THE INVENTION

The present invention generally relates to self-expanding medical devices. More precisely, the present invention relates to self-expanding medical devices made of radiopaque nitinol that can be used in essentially any body lumen. Such devices include stents.

5 Stents are typically implanted in a body lumen, such as carotid arteries, coronary arteries, peripheral arteries, veins, or other vessels to maintain the patency of the lumen. These devices are frequently used in the treatment of atherosclerotic stenosis in blood vessels especially after percutaneous transluminal angioplasty (PTA) or percutaneous transluminal coronary angioplasty (PTCA) procedures with the intent
10 to reduce the likelihood of restenosis of a vessel. Stents are also used to support a body lumen, tack-up a flap or dissection in a vessel, or in general where the lumen is weak to add support.

 During PTCA procedures it is common to use a dilatation catheter to expand a diseased area to open the patient's lumen so that blood flows freely. Despite
15 the beneficial aspects of PTCA procedures and its widespread and accepted use, it has several drawbacks, including the possible development of restenosis and perhaps acute thrombosis and sub-acute closure. This recurrent stenosis has been estimated to occur in seventeen to fifty percent of patients despite the initial PTCA procedure being successful. Restenosis is a complex and not fully understood biological response to
20 injury of a vessel which results in chronic hyperplasia of the neointima. This neointimal hyperplasia is activated by growth factors which are released in response to injury. Acute thrombosis is also a result of vascular injury and requires systemic antithrombotic drugs and possibly thrombolytics as well. This therapy can increase bleeding complications at the catheter insertion site and may result in a longer hospital
25 stay. Sub-acute closure is a result of thrombosis, elastic recoil, and/or vessel dissection.

 Several procedures have been developed to combat restenosis and sub-acute or abrupt closure, one of which is the delivery and implanting of an intravascular stent.

Stents are widely used throughout the United States and in Europe and other countries. Generally speaking, the stents can take numerous forms. One of the most common is a generally cylindrical, hollow tube that holds open the vascular wall at the area that has been dilated by a dilation catheter. One highly regarded stent used and sold in the
5 United States is known under the tradename ACS Multi-Link Stent, which is made by Advanced Cardiovascular Systems, Inc., Santa Clara, California.

In expandable stents that are delivered with expandable catheters, such as balloon catheters, the stents are positioned over the balloon portion of the catheter and are expanded from a reduced diameter to an enlarged diameter greater than or equal to
10 the inner diameter of the arterial wall by inflating the balloon. Stents of this type can be expanded to an enlarged diameter by deforming the stent, by engagement of the stent walls with respect to one another, and by one way engagement of the stent walls together with endothelial growth onto and over the stent.

Examples of intravascular stents can be found in U.S. Patent No. 5,292,331
15 (Boneau); U.S. Patent No. 4,580,568 (Gianturco); U.S. Patent No. 4,856,516 (Hillstead); U.S. Patent No. 5,092,877 (Pinchuk); and U.S. Patent No. 5,514,154 (Lau et al.), which are incorporated herein by reference in their entirety.

The problem with some prior art stents, especially those of the balloon expandable type, is that they are often stiff and inflexible. These balloon expandable
20 type stents are commonly formed from stainless steel alloys and the stents are constructed so that they are expanded beyond their elastic limit. As a result, such stents are permanently deformed by the inflation balloon beyond their elastic limits to hold open a body lumen and thus maintain patency of that body lumen. There are several commercially available balloon expandable stents that are widely used; they are
25 generally implanted in the coronary arteries after a PTCA procedure mentioned earlier.

Stents are often times implanted in vessels that are closer to the surface of the body, such as in the carotid arteries in the neck or in peripheral arteries and veins in the leg. Because these stents are so close to the surface of the body, they are particularly vulnerable to impact forces that can partially or completely collapse the

stent and thereby block fluid flow in the vessel. Other forces can impact balloon expandable stents and cause similar partial or total vessel blockage. For instance, under certain conditions, muscle contractions might also cause balloon expandable stents to collapse partially or completely. The collapse occludes the lumen and restricts blood
5 flow in the vessel in which they are implanted.

Since balloon expandable stents are plastically deformed, once collapsed or crushed they remain so, permanently blocking the vessel. Thus, balloon expandable stents under certain conditions might pose an undesirable condition for the patient.

Self-expanding stents as the name implies self-expand through the
10 properties of the material constituting the stent. The inflation force of a balloon catheter is usually not necessary to deploy this kind of stent.

Important applications including those mentioned above have prompted designers to seek out superelastic shape memory alloys to exploit the materials' properties in their self-expanding stents. Examples of applying superelastic nickel-titanium alloys to a self-expanding stent and other medical devices are disclosed in U.S.
15 Patent Nos. 4,665,906; 5,067,957; 5,190,546; and 5,597,378 to Jervis and U.S. Patent No. 4,503,569 to Dotter. Another example is disclosed in European Patent Application Publication No. EP0873734A2, entitled "Shape Memory Alloy Stent." This publication suggests a stent for use in a lumen in a human or animal body having a
20 generally tubular body formed from a shape memory alloy which has been treated so that it exhibits enhanced elastic properties. The publication further suggests use of specified ternary elements in a nickel-titanium alloy to obtain desired engineering characteristics.

Use of a ternary element in a superelastic stent is also shown in, for
25 example, U.S. Patent No. 5,907,893 to Zadno-Azizi et al. As a general proposition, there have been attempts at adding a ternary element to nickel-titanium alloys as disclosed in, for instance, U.S. Patent No. 5,885,381 to Mitose et al.

Clearly, self-expanding, nickel-titanium stents are useful and valuable to the medical field. But a distinct disadvantage with self-expanding nickel-titanium stents

is the fact that they are not sufficiently radiopaque as compared to a comparable structure made from gold or tantalum. For example, radiopacity permits the cardiologist or physician to visualize the procedure involving the stent through use of fluoroscopes or similar radiological equipment. Good radiopacity is therefore a useful
5 feature for self-expanding nickel-titanium stents to have.

Radiopacity can be improved by increasing the strut thickness of the nickel-titanium stent. But increasing strut thickness detrimentally affects the flexibility of the stent, which is a quality necessary for ease of delivery. Another complication is that radiopacity and radial force co-vary with strut thickness. Also, nickel-titanium is
10 difficult to machine and thick struts exacerbates the problem.

Radiopacity can be improved through coating processes such as sputtering, plating, or co-drawing gold or similar heavy metals onto the stent. These processes, however, create complications such as material compatibility, galvanic corrosion, high manufacturing cost, coating adhesion or delamination, biocompatibility, loss of coating
15 integrity following collapse and deployment of the stent, etc.

Radiopacity can also be improved by alloy addition. One specific approach is to alloy the nickel-titanium with a ternary element. What has been needed and heretofore unavailable in the prior art is a superelastic nickel-titanium stent that includes a ternary element to increase radiopacity yet preserves the superelastic
20 qualities of the nitinol.

SUMMARY OF THE INVENTION

The present invention relates to a radiopaque medical device, such as a stent, for use or implantation in a body lumen. In a preferred embodiment, a
25 radiopaque medical device, such as a stent, is constructed from a tubular-shaped body having a thin wall defining a strut pattern; wherein the tubular body includes a superelastic, nickel-titanium alloy, and the alloy further includes a ternary element selected from the group of chemical elements consisting of iridium, platinum, gold, rhenium, tungsten, palladium, rhodium, tantalum, silver, ruthenium, or hafnium. In a

preferred embodiment, the stent according to the present invention has 42.8 atomic percent nickel, 49.7 atomic percent titanium, and 7.5 atomic percent platinum.

As a result, the present invention stent is highly radiopaque as compared to an identical structure made of medical grade stainless steel that is coated with a thin
5 layer of gold. From another perspective, for a given stent having a certain level of radiopacity, the present invention stent having identical dimensions and strut pattern has at least a 10 percent reduction in strut thickness yet maintains that same level of radiopacity.

Self-expanding nitinol stents are collapsed (that is, loaded) and then
10 constrained within a delivery system. At the point of delivery, the stent is released (that is, unloaded) and allowed to return to its original diameter. The stent is designed to perform various mechanical functions within the lumen, all of which are based upon the lower unloading plateau stress. Therefore, it is crucial that the ternary element alloyed with the binary nickel-titanium does not diminish the superelastic
15 characteristics of the nickel-titanium.

To achieve the sufficient degree of radiopacity yet maintaining the superelastic engineering properties of a binary nickel-titanium, preferably, the radiopaque stent of the present invention includes platinum whose atomic percent is greater than or equal to 2.5 and less than or equal to 15. In an alternative embodiment,
20 the nickel-titanium is alloyed with palladium whose atomic percent is greater than or equal to 2.5 and less than or equal to 20. With such compositions, the stress-strain hysteresis curve of the present invention radiopaque nitinol alloy closely approximates the idealized stress-strain hysteresis curve of binary nickel-titanium.

The present invention further contemplates a method for providing a
25 radiopaque nitinol stent. In a preferred embodiment, the method entails providing a tubular-shaped body having a thin wall, wherein the body includes a superelastic nickel-titanium alloy and the alloy further includes a ternary element selected from the group of chemical elements consisting of iridium, platinum, gold, rhenium, tungsten, palladium, rhodium, tantalum, silver, ruthenium, or hafnium; forming a strut pattern;

wherein the stent is highly radiopaque. The step of providing a tubular-shaped body includes melting nickel, titanium, and the ternary element and cooling the mixture to form an alloy ingot, hot forming the alloy ingot, hot or cold forming the alloy ingot into a cylinder, drilling the cylinder to form tubing, cold drawing the tubing, and annealing
5 the tubing.

The present invention of course envisions the minor addition of a quaternary element, for example, iron, to further enhance the alloy's formability or its thermomechanical properties. In short, the presence of elements in addition to the ternary elements cited above is contemplated.

10 In a preferred embodiment, an austenite finish temperature (A_f) of the superelastic alloy in the stent is greater than or equal to zero and less than or equal to 37 degrees C. Also in the preferred embodiment, the ingot after melting includes an austenite finish temperature (A_f) of greater than or equal to 0 degrees C and less than or equal to 40 degrees C. The tubing includes an austenite finish temperature (A_f) of
15 greater than or equal to -15 degrees C and less than or equal to 15 degrees C.

Other features and advantages of the present invention will become more apparent from the following detailed description of the invention when taken in conjunction with the accompanying exemplary drawings.

20 BRIEF DESCRIPTION OF THE DRAWINGS

FIG. 1 is a side elevational view, partially in section, depicting a stent mounted on a delivery catheter and expanded within a damaged vessel, pressing a damaged vessel lining against the vessel wall.

FIG. 2 is a side elevational view, partially in section, depicting an expanded
25 stent within the vessel after withdrawal of the delivery catheter.

FIG. 3 is an idealized stress-strain hysteresis curve for a superelastic material.

FIG. 4 is a plan view of the flattened strut pattern of an exemplary embodiment superelastic stent.

FIG. 5 is a group of empirical data curves illustrating the highly similar stress-strain relationships among binary nitinol and the nickel-titanium-palladium and nickel-titanium-platinum alloys used in the present invention.

5 DETAILED DESCRIPTION OF THE PREFERRED EMBODIMENTS

The present invention relates to a medical device made of radiopaque nitinol. For the sake of illustration, the following exemplary embodiments are directed to stents, although it is understood that the present invention is applicable to other medical devices usable in a body lumen as well.

10 The stents of the present invention can have virtually any configuration that is compatible with the body lumen in which they are implanted. The stent should preferably be configured so that there is a substantial amount of open area and preferably the open area to metal ratio is at least 80 percent. The stent should also be configured so that dissections or flaps in the body lumen wall are covered and tacked
15 up by the stent.

Referring to FIGS. 1, 2, and 4, in a preferred embodiment, a stent 10 of the present invention is formed partially or completely of alloys such as nitinol (NiTi) which have superelastic (SE) characteristics. Stent 10 is somewhat similar to the stent disclosed in United States Patent No. 5,569,295, "Expandable Stents and Method for
20 Making Same," issued to Lam on October 29, 1996, which patent is incorporated herein by reference. Some differences of the present invention stent from that disclosed in the '295 patent is that the present invention stent is preferably constructed of a superelastic material with the addition of a ternary element, and the strut pattern has changed. Of course, the configuration of the stent 10 is just one example of many
25 stent configurations that are contemplated by the present invention.

Turning to FIG. 4, stent 10 has a tubular form which preferably includes a plurality of radially expandable cylindrical elements 24 disposed generally coaxially and interconnected by members 26 disposed between adjacent cylindrical elements 24. The shapes of the struts 12 forming the strut pattern are designed so they can preferably

be nested. This strut pattern is best seen from the flattened plan view of FIG. 4. The serpentine patterned struts 12 are nested such that the extended portions of the struts of one cylindrical element 24 intrude into a complementary space within the circumference of an adjacent cylindrical element. In this manner, the plurality of cylindrical elements 24 can be more tightly packed lengthwise.

As introduced above, an exemplary stent of the present invention includes a superelastic material. In a general sense, superelasticity implies that the material can undergo a large degree of reversible strain as compared to common steel. In a technical sense, the term “superelasticity” and sometimes “pseudoelasticity” refer to an isothermal transformation in nitinol. More specifically, it refers to stress inducing a martensitic phase from an austenitic phase. Alloys having superelastic properties generally have at least two phases: a martensitic phase, which has a relatively low tensile strength and which is stable at relatively low temperatures, and an austenitic phase, which has a relatively high tensile strength and which is stable at temperatures higher than the martensitic phase. Superelastic characteristics generally allow the metal stent to be deformed by collapsing the stent and creating stress which causes the NiTi to reversibly change to the martensitic phase. The stent is restrained in the deformed condition inside a delivery sheath typically to facilitate the insertion into a patient’s body, with such deformation causing the isothermal phase transformation. Once within the body lumen, the restraint on the stent is removed, thereby reducing the stress thereon so that the superelastic stent returns towards its original undeformed shape through isothermal transformation back to the austenitic phase. Under these conditions, the stent can be described as self-expanding.

Returning to FIG. 1, the graphic illustrates, in a partial cross-sectional view, the distal end of a rapid exchange stent delivery system that includes a guide wire 14, a delivery sheath 16, and an intravascular catheter 18. For the sake of clarity, the illustration of the delivery system in FIG. 1 has been simplified. It is just one example of a delivery system that may be used with the present invention. More details of a delivery system specifically for use with a self-expanding stent may be found in, for

example, U.S. Patent No. 6,077,295 to Limon et al., entitled "Self-Expanding Stent Delivery System," which is incorporated herein by reference. Other delivery systems such as over-the-wire may be used without departing from the scope of the instant invention.

5 FIG. 1 further shows an optional expandable balloon 20 inflated through an inflation lumen (not shown), although the balloon is typically not needed for a self-expanding stent. The stent 10 is first crimped on to the deflated balloon 20, and the entire assembly is kept underneath the delivery sheath 16 until the moment the stent 10 is deployed. The stent 10 is self-expanding so that when the sheath 16 is withdrawn,
10 the stent 10 expands to its larger deployment diameter without assistance from the balloon 20. Nevertheless, some procedures specifically use the balloon 20 to further expand the stent 10 for improved seating in the artery wall 29.

 FIG. 2 illustrates the self-expanding stent 10 in the expanded condition after the delivery system has been removed. If an external force is applied to the artery 28,
15 the expanded stent 10 temporarily and at least partially collapses or deforms. As the stent 10 deforms, stress in the nickel-titanium alloy causes an isothermal phase transformation from the austenitic phase to the martensitic phase. When the external force is removed, the stress in stent 10 is likewise diminished so that the stent quickly transforms back from the martensitic phase to the austenitic phase. As this almost
20 instantaneous, isothermal transformation occurs, the stent 10 returns to its fully expanded state and the artery remains open. When the superelastic stent 10 is implanted in an artery 28, its high resilience effectively maintains the patency of the artery while minimizing the risk of permanent arterial collapse at the implant site if the stent is temporarily deformed due to external forces. Furthermore, the resilience of the
25 stent 10 supports the flap 30 to maintain patency of the artery.

 Stent 10 is preferably formed from a superelastic material such as nickel-titanium and undergoes an isothermal transformation when stressed if in the austenitic phase. For most purposes, the transformation temperature for the stent 10 is preferably set low enough such that the nickel-titanium alloy is in the austenitic phase while at

body temperature.

According to theory, when stress is applied to a specimen of a metal such as nitinol exhibiting superelastic characteristics at a temperature at or above that which the transformation of the martensitic phase to the austenitic phase is complete, the specimen deforms elastically until it reaches a particular stress level where the alloy then undergoes a stress-induced phase transformation from the austenitic phase to the martensitic phase. As the phase transformation progresses, the alloy undergoes significant increases in strain with little or no corresponding increases in stress. The strain increases while the stress remains essentially constant until the transformation of the austenitic phase to the martensitic phase is complete. Thereafter, further increase in stress is necessary to cause further deformation. The martensitic metal first yields elastically upon the application of additional stress and then plastically with permanent residual deformation.

If the load on the specimen is removed before any permanent deformation has occurred, the stress-induced martensite elastically recovers and transforms back to the austenitic phase. The reduction in stress first causes a decrease in strain. As stress reduction reaches the level at which the martensitic phase begins to transform back into the austenitic phase, the stress level in the specimen remains essentially constant (but less than the constant stress level at which the austenitic crystalline structure transforms to the martensitic crystalline structure until the transformation back to the austenitic phase is complete); i.e., there is significant recovery in strain with only negligible corresponding stress reduction. After the transformation back to austenite is complete, further stress reduction results in elastic strain reduction. This ability to incur significant strain at relatively constant stress upon the application of a load and to recover from the deformation upon the removal of the load is commonly referred to as “superelasticity” and sometimes “pseudoelasticity.”

FIG. 3 illustrates an idealized stress-strain hysteresis curve for a superelastic, binary nickel-titanium alloy. The relationship is plotted on x-y axes, with the x axis representing strain and the y axis representing stress. For ease of illustration,

the x-y axes are labeled on a scale typical for superelastic nitinol, with stress from 0 to 60 ksi and strain from 0 to 9 percent, respectively.

Looking at the plot in FIG. 3, the line from point A to point B represents the elastic deformation of the nickel-titanium alloy. After point B the strain or deformation
5 is no longer proportional to the applied stress and it is in the region between point B and point C that the stress-induced transformation of the austenitic phase to the martensitic phase begins to occur.

At point C moving toward point D, the material enters a region of relatively constant stress with significant deformation or strain. This constant or plateau region
10 is known as the loading stress, since it represents the behavior of the material as it encounters continuous increasing strain. It is in this plateau region C-D that the transformation from austenite to martensite occurs.

At point D the transformation to the martensitic phase due to the application of stress to the specimen is substantially complete. Beyond point D the martensitic
15 phase begins to deform, elastically at first, but, beyond point E, the deformation is plastic or permanent.

When the stress applied to the superelastic metal is removed, the material behavior follows the curve from point E to point F. Within the E to F region, the martensite recovers its original shape, provided that there was no permanent
20 deformation to the martensitic structure. At point F in the recovery process, the metal begins to transform from the stress-induced, unstable, martensitic phase back to the more stable austenitic phase.

In the region from point G to point H, which is also an essentially constant or plateau stress region, the phase transformation from martensite back to austenite
25 takes place. This constant or plateau region G-H is known as the unloading stress. The line from point I to the starting point A represents the elastic recovery of the metal to its original shape.

Binary nickel-titanium alloys that exhibit superelasticity have an unusual stress-strain relationship as just described and as plotted in the curve of FIG. 3. As

emphasized above, the superelastic curve is characterized by regions of nearly constant stress upon loading, identified above as loading plateau stress C-D and unloading plateau stress G-H. Naturally, the loading plateau stress C-D always has a greater magnitude than the unloading plateau stress G-H. The loading plateau stress represents the period during which martensite is being stress-induced in favor of the original austenitic crystalline structure. As the load is removed, the stress-induced martensite transforms back into austenite along the unloading plateau stress part of the curve. The difference in stress between the stress at loading C-D and unloading stress G-H defines the hysteresis of the system.

10 The present invention seeks to preserve the superelastic qualities of nickel-titanium alloys just described yet improve upon the material's radiopacity by addition of a ternary element. This is preferably accomplished in one embodiment by forming a composition consisting essentially of about 30 to about 52 percent titanium and the balance nickel and up to 10 percent of one or more additional ternary alloying
15 elements. Such ternary alloying elements may be selected from the group consisting of iridium, platinum, gold, rhenium, tungsten, palladium, rhodium, tantalum, silver, ruthenium, or hafnium. In the preferred embodiment, the atomic percentage of platinum is greater than or equal to 2.5 and less than or equal to 15. In an alternative embodiment, the atomic percentage of palladium is greater than or equal to 2.5 and less
20 than or equal to 20.

A preferred embodiment stent according to the present invention has 42.8 atomic percent nickel, 49.7 atomic percent titanium, and 7.5 atomic percent platinum. Through empirical studies, the aforementioned compositions produce stent patterns having a radiopacity comparable to the same size and pattern stent made from 316 L
25 stainless steel with a 2.7 to 6.5 μm gold coating.

In various alternative embodiments, the present invention contemplates the minor addition of a quaternary element, for example, iron, to further enhance the alloy's formability or its thermomechanical properties. The presence of impurities such as carbon or oxygen or the like in the present invention alloy is also possible.

A preferred method of fabricating the present invention superelastic, radiopaque metallic stent entails first fashioning nickel-titanium tubing. The tubing is made from vacuum induction melting nickel and titanium with the ternary element according to the compositions suggested above. The ingot is then remelted for consistency. The ingot is next hot rolled into bar stock, then straightened and sized, and hot or cold formed into a cylinder. The cylinder is gun drilled to form the tubing. Instead of gun drilling, other methods of material removal known in the art may be used, including electric discharge machining (EDM), laser beam machining, and the like. Next, the tubing is cold drawn and annealed repeatedly to achieve the finished dimensions.

Any of the foregoing preferred embodiment steps may be repeated, taken out of sequence, or omitted as necessary depending on desired results. From here on, the tubing follows conventional stent fabrication techniques such as laser cutting the strut pattern, heat setting, etc.

The following are additional processing guide posts for the present invention to achieve a sufficiently radiopaque stent yet maintaining the superelastic stress-strain behavior of the alloy. Empirical evidence suggests that, in various preferred embodiments, a Ni-Ti-Pd or Ni-Ti-Pt ingot should have the following austenite finish temperature: $0 \text{ degrees C} \leq A_f \leq 40 \text{ degrees C}$. The Ni-Ti-Pd or Ni-Ti-Pt tubing should exhibit an austenite finish temperature of: $-15 \text{ degrees C} \leq A_f \leq 15 \text{ degrees C}$. In an exemplary embodiment, the final laser cut Ni-Ti-Pd or Ni-Ti-Pt stent should exhibit an austenite finish temperature of: $0 \text{ degrees C} \leq A_f \leq 37 \text{ degrees C}$. Of course, the A_f of the finished laser cut stent can be set as needed by various heat treating processes known in the art.

It is understood that the austenite finish temperature (A_f) is defined to mean the temperature at which the material completely reverts to austenite. In technical terms, the A_f (and other transformation temperatures A_s , M_s , M_f) as it applies to an ingot made of Ni-Ti-Pd or Ni-Ti-Pt, for example, is determined by a Differential

Scanning Calorimeter (DSC) test, known in the art. The DSC test method to determine transformation temperatures for the ingot is guided by ASTM standard no. F 2004-00, entitled "Standard Test Method For Transformation Temperature Of Nickel-Titanium Alloys By Thermal Analysis."

5 The "active A_f " for the tubing and the finished stent is determined by a bend and free recovery test, also known in the art. In such a test, the tubing is cooled to under the M_f temperature, deformed, and warmed up. While monitoring the increasing temperature, the point of final recovery of the deformation in the tubing approximates the A_f of the material. The active A_f testing technique is guided by a second ASTM
10 standard entitled "Standard Test Method For Determination Of Transformation Temperature Of Nickel-Titanium Shape Memory Alloys By Bend And Free Recovery," or by equivalent test methods known in the art.

 Samples of wire made in accordance with the foregoing exemplary embodiments were tested. Specifically, the stress-strain relationship based on
15 empirical data for nickel-titanium-palladium and nickel-titanium-platinum are plotted against binary nitinol in FIG. 5. Curve A corresponds to a sample of nickel-titanium-platinum. Curve B is based on a sample of binary nitinol. Curve C is based on a sample of nickel-titanium-palladium. To generate the empirical data, the wire samples were placed under increasing tension until past the phase transformation from their
20 initial austenitic phase to their martensitic phase. Tension was then slowly released prior to any plastic deformation until stress on the samples dropped to zero with full deformation recovery.

 As is apparent from the plot of FIG. 5, the present invention nickel-titanium-palladium and nickel-titanium-platinum alloys have stress-strain curves that
25 closely follow the hysteresis curve for binary nitinol. All three curves have essentially flat loading and unloading plateau stresses indicating the presence of a phase transformation that is characteristic of superelastic metals. Hence, the present invention nitinol stent incorporates a ternary element, in these exemplary embodiments palladium or platinum, to improve radiopacity yet the materials' superelastic capability

is preserved. What has been missing heretofore is empirical evidence that this level of radiopacity can be achieved while preserving the superelastic characteristics of these alloys.

The present invention further provides a nitinol stent having improved
5 radiopacity without reliance on increasing the stent wall thickness or strut thickness. Increasing wall or strut thicknesses detracts from the flexibility of the stent, which is detrimental to deliverability. Rather, the present invention superelastic nitinol stent has a thin wall/strut thickness and/or strut cross-sectional area akin to a conventional stainless steel stent, and has comparable radiopacity to a stainless steel stent with a thin
10 coating of gold. The wall/strut thickness is defined by the difference between the inside diameter and the outside diameter of the tube.

Indeed, the improved radiopacity of the present invention stent can be characterized strictly by strut thickness. In this context, the present invention radiopaque stent has a reduced strut thickness yet exhibits the radiopacity of an
15 identical stent having thicker struts. In other words, given a stent exhibiting a certain level of radiopacity, the present invention stent having the identical dimensions and strut pattern achieves that level of radiopacity yet it has at least a 10 percent reduction in strut thickness as compared to the reference stent.

Alternatively, the 10 percent reduction can also be quantified in terms of the
20 cross-sectional area of the strut. That is, for a given stent having a certain level of radiopacity with struts with a given cross-sectional area, the present invention stent having the same dimensions and strut pattern achieves the same level of radiopacity but has struts with at least a 10 percent reduction in cross-sectional area as compared to the reference stent.

25 Another aspect of nitinol aside from its superelasticity is shape memory. The present invention can also be employed with respect to this physical attribute as described below.

The shape memory effect allows a nitinol structure to be deformed to facilitate its insertion into a body lumen or cavity, and then heated within the body so

that the structure returns to its original, set shape. Nitinol alloys having shape memory effect generally have at least two phases: a martensitic phase, which has a relatively low tensile strength and which is stable at relatively low temperatures, and an austenitic phase, which has a relatively high tensile strength and which is stable at temperatures
5 higher than the martensitic phase.

Shape memory effect is imparted to the alloy by heating the nickel-titanium metal to a temperature above which the transformation from the martensitic phase to the austenitic phase is complete; i.e., a temperature above which the austenitic phase is stable. The shape of the metal during this heat treatment is the shape "remembered."
10 The heat-treated metal is cooled to a temperature at which the martensitic phase is stable, causing the austenitic phase to transform to the martensitic phase. The metal in the martensitic phase is then plastically deformed, e.g., to facilitate the entry thereof into a patient's body. Subsequent heating of the deformed martensitic phase to a temperature above the martensite to austenite transformation temperature causes the
15 deformed martensitic phase to transform to the austenitic phase. During this phase transformation the metal reverts back towards its original shape.

The recovery or transition temperature may be altered by making minor variations in the composition of the metal and in processing the material. In developing the correct composition, biological temperature compatibility must be determined in
20 order to select the correct transition temperature. In other words, when the stent is heated, it must not be so hot that it is incompatible with the surrounding body tissue. Other shape memory materials may also be utilized, such as, but not limited to, irradiated memory polymers such as autocrosslinkable high density polyethylene (HDPEX). Shape memory alloys are known in the art and are discussed in, for
25 example, "Shape Memory Alloys," Scientific American, Vol. 281, pp. 74-82 (November 1979), incorporated herein by reference.

Shape memory alloys undergo a transition between an austenitic phase and a martensitic phase at certain temperatures. When they are deformed while in the martensitic phase, they retain this deformation as long as they remain in the same

phase, but revert to their original configuration when they are heated to a transition temperature, at which time they transform to their austenitic phase. The temperatures at which these transitions occur are affected by the nature of the alloy and the condition of the material. Nickel-titanium-based alloys (NiTi), wherein the transition
5 temperature is slightly lower than body temperature, are preferred for the present invention. It is desirable to have the transition temperature set at just below body temperature to insure a rapid transition from the martensitic state to the austenitic state when the stent is implanted in a body lumen.

Turning again to FIGS. 1, 2, and 4, the present invention stent 10 is formed
10 from a shape memory alloy, such as NiTi discussed above. After the stent 10 is inserted into an artery 28 or other vessel, the delivery sheath 16 is withdrawn exposing the stent 10 to the ambient environment. The stent 10 then immediately expands due to contact with the higher temperature within artery 28 as described for devices made from shape memory alloys. An optional expandable balloon 20 may be inflated by
15 conventional means to further expand the stent 10 radially outward.

Again, if an external force is exerted on the artery, the stent 10 temporarily at least partially collapses. But the stent 10 then quickly regains its former expanded shape due to its shape memory qualities. Thus, a crush-resistant stent, having shape memory characteristics, is implanted in a vessel. It maintains the patency of a vessel
20 while minimizing both the risk of permanent vessel collapse and the risk of dislodgment of the stent from the implant site if the stent is temporarily deformed due to external forces.

When the stent 10 is made in accordance with the present invention, it is also highly radiopaque. The same alloying processes described earlier are used here
25 to add the ternary element to increase the radiopacity of the stent. Insofar as the martensitic to austenitic phase transformation is thermally driven, the deployment of the present invention stent can be explained in terms of the shape memory effect.

While the present invention has been illustrated and described herein in terms of a radiopaque nitinol stent, it is apparent to those skilled in the art that the

present invention can be used in other instances. Other modifications and improvements may be made without departing from the scope of the present invention.

WHAT IS CLAIMED IS:

1. A radiopaque medical device for use in a body lumen, comprising:
a tubular-shaped body having a thin wall defining a strut pattern;
wherein the body includes a superelastic alloy, and the alloy further includes a ternary element selected from the group of chemical elements consisting of:
5 iridium, platinum, gold, rhenium, tungsten, palladium, rhodium, tantalum, silver, ruthenium, or hafnium; and
wherein the medical device exhibits a level of radiopacity.
2. The radiopaque medical device of claim 1, wherein the atomic percent of platinum is greater than or equal to 2.5 and less than or equal to 15.
3. The radiopaque medical device of claim 1, wherein the atomic percent of palladium is greater than or equal to 2.5 and less than or equal to 20.
4. The radiopaque medical device of claim 1, wherein the thin wall is at least 10 percent thinner than an identically-shaped and sized medical device having the same level of radiopacity.
5. The radiopaque medical device of claim 1, wherein the strut pattern has a cross-sectional area that is 10 percent smaller than a cross-sectional area of a strut of an identically-shaped and sized medical device having the same level of radiopacity.
6. The radiopaque medical device of claim 1, wherein the superelastic alloy includes a nickel-titanium alloy.
7. The radiopaque medical device of claim 6, wherein the atomic percent of titanium is greater than or equal to 46 and less than or equal to 52.
8. The radiopaque medical device of claim 6, wherein an austenite finish temperature (A_f) of the superelastic alloy in the stent is greater than or equal to zero and less than or equal to 37 degrees C.
9. The radiopaque medical device of claim 6, wherein the tubular-shaped body includes raw tubing having an austenite finish temperature (A_f) of greater than or equal to -15 degrees C and less than or equal to 15 degrees C.

10. A superelastic, radiopaque metallic stent for medical applications, comprising:

a tubular-shaped body having a thin wall defining a strut pattern;

wherein the body includes a superelastic nickel-titanium alloy and the alloy
5 further includes a third element selected from the group of chemical elements consisting of: iridium, platinum, gold, rhenium, tungsten, palladium, rhodium, tantalum, silver, ruthenium, or hafnium; and

wherein the stent exhibits a level of radiopacity.

11. The superelastic, radiopaque metallic stent of claim 10, wherein the radiopacity of the stent is substantially equivalent to a 316L stainless steel stent having an identical strut pattern and size and coated with 2.7 to 6.5 μm of gold.

12. The superelastic, radiopaque metallic stent of claim 10, wherein the atomic percent of platinum is greater than or equal to 2.5 and less than or equal to 15.

13. The superelastic, radiopaque metallic stent of claim 10, wherein the atomic percent of palladium is greater than or equal to 2.5 and less than or equal to 20.

14. The superelastic, radiopaque metallic stent of claim 10, wherein the thin wall is at least 10 percent thinner than an identically strut patterned stent having a substantially equivalent level of radiopacity.

15. The superelastic, radiopaque metallic stent of claim 10, wherein the strut pattern is laser cut from a tube.

16. A method for providing a superelastic, radiopaque metallic stent for medical applications, comprising:

providing a tubular-shaped body having a thin wall, wherein the body includes a superelastic nickel-titanium alloy and the alloy further includes a ternary
5 element selected from the group of chemical elements consisting of: iridium, platinum, gold, rhenium, tungsten, palladium, rhodium, tantalum, silver, ruthenium, or hafnium; forming a strut pattern; wherein the stent is radiopaque.

17. The method of claim 16, wherein the step of providing a tubular-shaped body includes melting nickel, titanium, and the ternary element, cooling to form an alloy ingot, hot forming the alloy ingot, forming the alloy ingot into a cylinder, drilling the cylinder to form tubing, drawing the tubing, and annealing the tubing.

18. The method of claim 16, wherein the atomic percent of platinum is greater than or equal to 2.5 and less than or equal to 15.

19. The method of claim 16, wherein the atomic percent of palladium is greater than or equal to 2.5 and less than or equal to 20.

20. The method of claim 16, wherein an austenite finish temperature (A_f) of the superelastic alloy in the stent is greater than or equal to zero and less than or equal to 37 degrees C.

21. The method of claim 17, wherein the ingot after melting includes an austenite finish temperature (A_f) of greater than or equal to 0 degrees C and less than or equal to 40 degrees C.

22. The method of claim 17, wherein the tubing includes an austenite finish temperature (A_f) of greater than or equal to -15 degrees C and less than or equal to 15 degrees C.

23. The method of claim 17, wherein the ingot is remelted.

24. The method of claim 16, wherein the alloy includes a quaternary element.

1/3

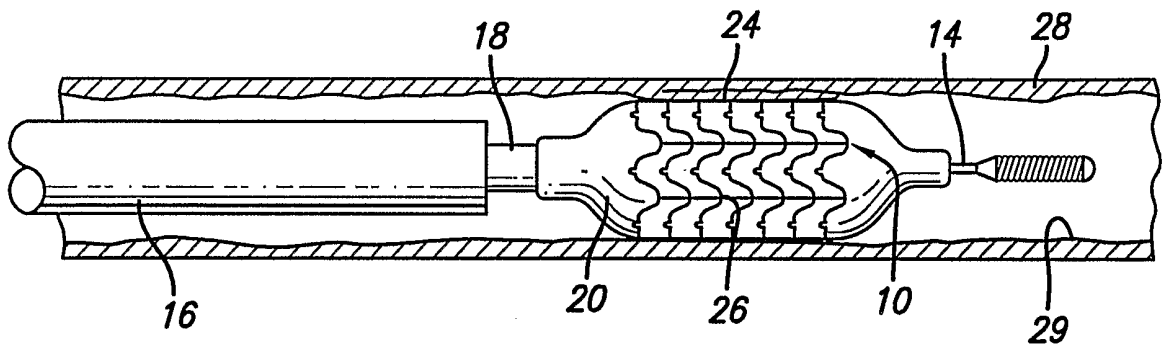

FIG. 1

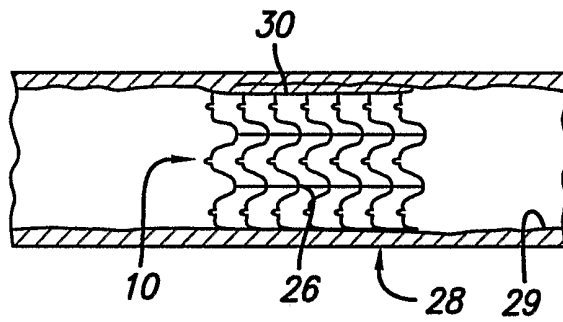

FIG. 2

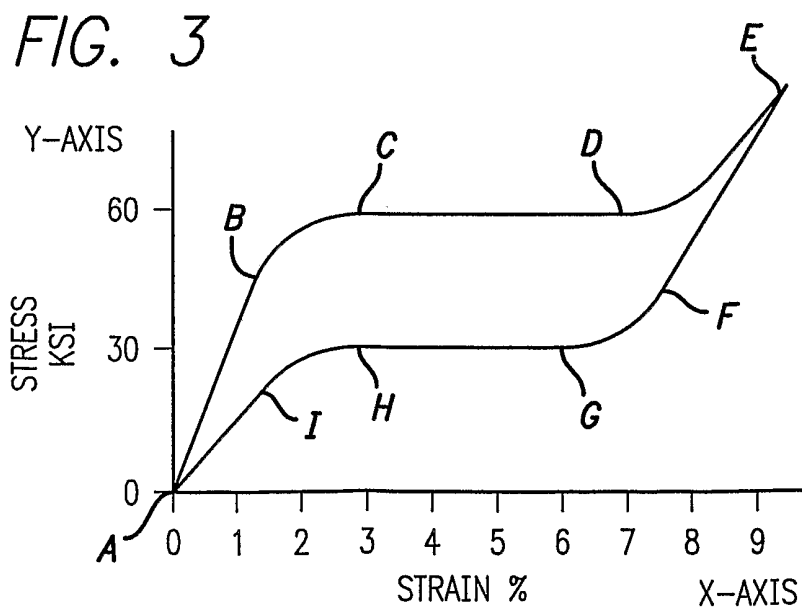

FIG. 3

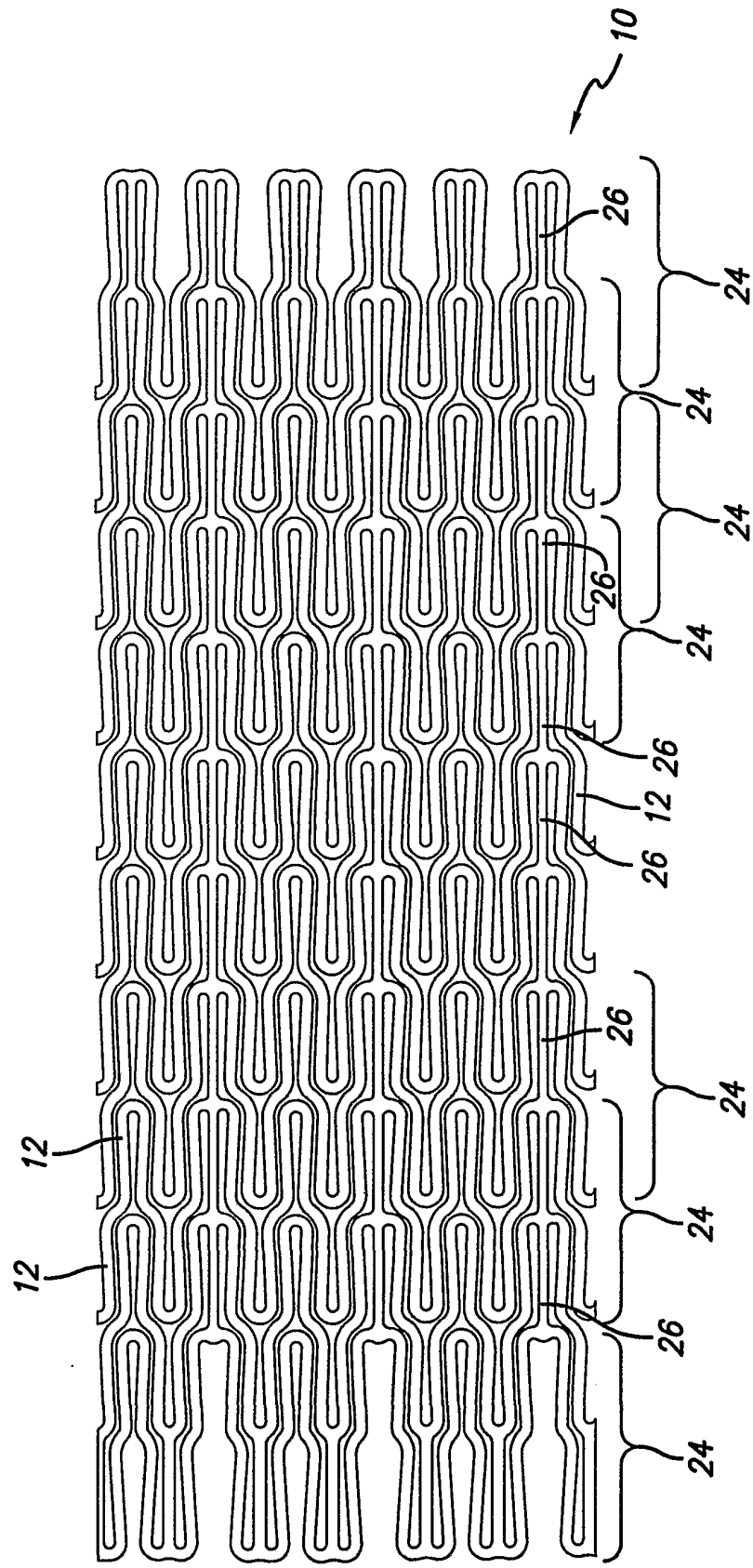

FIG. 4

FIG. 5

