



(11) **EP 2 500 114 A1**

(12) **EUROPEAN PATENT APPLICATION**
published in accordance with Art. 153(4) EPC

(43) Date of publication:
19.09.2012 Bulletin 2012/38

(21) Application number: **09851110.8**

(22) Date of filing: **09.11.2009**

(51) Int Cl.:
B21B 1/36 (2006.01) **B21B 15/00** (2006.01)
B21B 37/18 (2006.01) **B21B 37/32** (2006.01)
B21B 37/38 (2006.01) **B21B 41/00** (2006.01)

(86) International application number:
PCT/JP2009/069064

(87) International publication number:
WO 2011/055458 (12.05.2011 Gazette 2011/19)

(84) Designated Contracting States:
**AT BE BG CH CY CZ DE DK EE ES FI FR GB GR
HR HU IE IS IT LI LT LU LV MC MK MT NL NO PL
PT RO SE SI SK SM TR**

(71) Applicant: **Mitsubishi-Hitachi Metals Machinery,
Inc.**
Tokyo 108-0014 (JP)

(72) Inventors:
• **KAGA, Shinichi**
Tokyo 108-0014 (JP)
• **ONOSE, Mitsuru**
Tokyo 108-0014 (JP)
• **TOMINAGA, Noriaki**
Hiroshima-shi
Hiroshima 733-8553 (JP)

- **SAITO, Takehiko**
Hiroshima-shi
Hiroshima 733-8553 (JP)
- **YOSHIMURA, Yasutsugu**
Tokyo 108-0014 (JP)
- **MASUDA, Toyotsugu**
Tokyo 108-0014 (JP)
- **MAENO, Ichirou**
Tokyo 108-0014 (JP)

(74) Representative: **Beetz & Partner**
Patentanwälte
Steinsdorfstraße 10
80538 München (DE)

(54) **COLD ROLLING APPARATUS AND METHOD FOR COLD ROLLING**

(57) Disclosed are cold-rolled material manufacturing equipment and a cold rolling method by which a high efficiency, a high yield and a high investment cost-effectiveness are realized in a small- to medium-scale plant with a capacity of about 300,000 to 600,000 tons of product per year. A strip of a coil 101a unwound from a unwinding device 2 is guided directly to a cold rolling mill 1 to be rolled and then wound onto a winding/unwinding device 4. Upon arrival of the tail end of the coil 101a at a joining device 5, the coil 101a and the leading end of a coil 101b subsequently unwound from the unwinding device 2 are joined. Subsequently, rolling and joining for the coil 101b and following coils are repeated to perform first-pass rolling by the cold rolling mill 1 and joining by the joining device 5, thereby forming a plurality of coils into one buildup coil 102. The buildup coil 102 is subjected to reversible rolling a predetermined number of times until a desired product strip thickness is reached. In the final pass, the buildup coil 102 is cut by a cutting device 6a or 6b, to form a plurality of coils 103.

FIG. 1

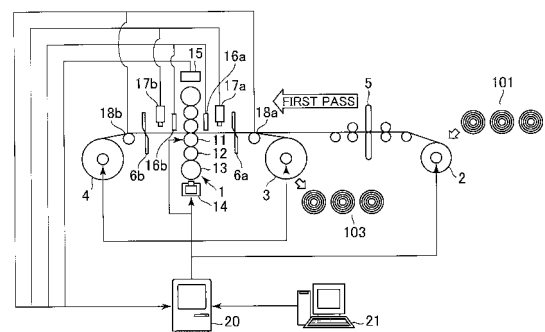

EP 2 500 114 A1

Description

Technical Field

5 **[0001]** The present invention, the invention relates to cold-rolled material manufacturing equipment and a cold rolling method.

Background Art

10 **[0002]** As rolling equipment for manufacturing cold-rolled materials of a variety of steels in small amounts of a total of about 300,000 tons of product per year, reversible cold rolling equipment (hereinafter referred to as RCM equipment) has been put to practical use which includes one cold rolling mill and strip winding/unwinding devices disposed respectively on the entry side and the delivery side of the cold rolling mill to be used for both winding and unwinding of strip and in which the strip is put to reversible rolling between the winding/unwinding devices on the entry side and the delivery side of the cold rolling mill, to roll the strip down to a desired strip thickness.

15 **[0003]** Furthermore, there has been equipment (hereinafter referred to as two-stand reverse equipment) which is provided with two rolling mills with an intention to increase the annual production of RCM equipment to a level of about 500,000 to 600,000 tons (see Patent Document 1).

20 **[0004]** In such RCM equipment, in a first pass and a second pass of rolling, the leading end of a strip should be passed in an unrolled state so as to obviate camber of the strip. In the third and following passes, also, a preceding-pass rolled section should be left in an unrolled state at a pass switching part. This results in that the unrolled sections at the leading end and tail end portions of the strip would come out of a product strip thickness range and would not be salable as a product. The strips falling out of the product strip thickness range in this manner are referred to as "off-gage". In regard of the ratio of the off-gage, the proportion of the amount of off-gages based on the gross production is defined as off-gage rate. The off-gage rate in each of various rolling equipment is about 2.5% for RCM equipment and about 6.0% for two-stand reverse equipment. On the other hand, in PL-TCM equipment in which a pickling step and a tandem cold milling step are carried out in a continuous manner, the off-gage rate is as low as about 0.2%. Thus, the equipment of the reversible rolling system have a problem in that the off-gage rate is about 2.5 to 6.0%, which is very high as compared with that of the PL-TCM equipment.

25 **[0005]** Especially, in the two-stand reverse equipment described in Patent Document 1, the off-gage is generated in about 6.0%, so that the yield is conspicuously low and the production cost is raised greatly.

30 **[0006]** Furthermore, in the reversible rolling system, as the coil tail end portion approaches the rolling mill in a preceding pass, the rolling mill is decelerated and the rolling is stopped. In the subsequent pass, the rolling mill is newly accelerated, for rolling in the reverse direction to that in the preceding pass. Thus, in the reversible rolling system, the deceleration and acceleration and the stopping of rolling are repeated by a number of times equal to the number of passes, until a desired product strip thickness is reached; therefore, the actual rolling time within a given operation time is short, and the production efficiency is poor.

35 **[0007]** In order to solve these problems, cold rolling equipment has been proposed which includes a cold rolling mill, a coil buildup line for joining a plurality of coils to form a single long coil, and a reversible rolling line for performing reversible rolling of the long coil thus built up (buildup coil) a predetermined number of times, and in which the buildup coil is cut in the final pass into coil lengths capable of being carried out (See Patent Document 2). In this cold rolling equipment, the strip length of the buildup coil can be enlarged to a level corresponding to the total strip length of the plurality of coils joined together, and the unrolled portions at the coil leading end and tail end sections are generated only at an innermost circumferential portion and an outermost circumferential portion of the buildup coil. Consequently, the off-gage rate can be remarkably lowered. In addition, the number of deceleration and acceleration operations at the coil tail end sections can be reduced by a number corresponding to the number of coils joined together, leading to enhanced production efficiency.

Prior Art Literature

50

Patent Documents

[0008]

55 Patent Document 1: Japanese Patent No. 3322984
Patent Document 2: Japanese Patent Publication No. Sho 57-039844

Summary of the Invention

Problems to be Solved by the Invention

- 5 **[0009]** The related art described in Patent Document 2 solves the problems involved in the related art described in Patent Document 1, and enables a high efficiency and a high yield, but it has the following problems.
- [0010]** First, there is a problem relating to a complicated configuration and an enlarged apparatus.
- 10 **[0011]** The related art described in Patent Document 2, in which a plurality of coils are built up to form a buildup coil and the buildup coil is rolled, needs a buildup-coil winding/unwinding device for forming the buildup coil, so that the number of winding/unwinding devices is increased as compared with that in the related art described in Patent Document 1.
- 15 **[0012]** In addition, in the related art described in Patent Document 2, a plurality of coils are built up to form a buildup coil having an enlarged diameter. In rolling the buildup coil having the enlarged diameter, the outside diameter of the coil is so large that a rolling tension exerted on the coil increases the coil tightening force tending to cause shrinkage toward the inside diameter side of the coil. Therefore, if a collapsible type reel having a variable diameter is applied to the winding/unwinding device, it becomes difficult to provide the reel with a strength for holding the coil tightening force. Thus, it is difficult to apply a collapsible type reel to the winding/unwinding device, and, for solving this problem, a solid block type reel having an invariable diameter has to be applied. On the other hand, at the time of dividing the buildup coil after completion of rolling so as to extract and carry out the cut coils, a winding/unwinding device having a collapsible type reel is needed, since the solid block type reel cannot be shrunk in diameter so as to extract the coil therefrom. Thus, in the related art described in Patent Document 2, a winding/unwinding device with a solid block type reel is needed at the time of rolling and a unwinding device with a collapsible type reel is needed at the time of carrying-out, so that the number of winding/unwinding devices is increased as compared with the related art described in Patent Document 1. Such a complication in configuration leads to a rise in initial cost.
- 20 **[0013]** In a plant of a comparatively large scale with an annual production of not less than 800,000 tons, the merit of a lowered off-gage rate and an enhanced production efficiency surpasses the demerit of an increased initial cost, so that the rise in the initial cost to some extent does not matter. In a small- to medium-scale plant with a capacity of about 300,000 to 600,000 tons of product per year, however, the problem of initial cost becomes conspicuous, leading to a problem from the viewpoint of cost-effectiveness.
- 25 **[0014]** Besides, in general, the joining devices applied to the use of cold rolling are a laser beam welding machine and a flash butt welding machine, which are of a butt joining system. These welding machines make it possible to secure a high butting accuracy; on the other hand, however, they use a large number of high-rigidity high-accuracy component parts, leading to larger equipment and a higher cost as compared with the other joining systems. When these welding machines are applied to a large-scale plant with an annual production in excess of 1,000,000 tons such as PL-TCM, the proportion of the welding machine cost based on the total plant and equipment investment is comparatively low and, hence, does not matter so much. When these welding machines are applied to a small- to medium-scale plant with an annual output of about 300,000 to 600,000 tons, however, the proportion is so high as to constitute a problem from the viewpoint of cost-effectiveness; therefore, the application is difficult to practice.
- 30 **[0015]** Secondly, there is a problem relating to the joint portion of the buildup coil.
- 35 **[0016]** In forming a buildup coil, it is ideal that the buildup coil is free of variations in thickness. In practice, however, some difference may exist between the strip thickness of a preceding coil and the strip thickness of a succeeding coil due to production errors or the like, leading to the generation of a step at the joint portion. When a tension is exerted on the buildup coil in the condition where a joint portion having a steep step is located at an inner layer portion of the buildup coil, the step at the joint portion would be transferred to the inside and the outside of each layer of coil, leading to a product defect that is dealt with as a crack.
- 40 **[0017]** In addition, where coils are joined by seam welding of a lap system, a step would be generated at the joint portion, similarly leading to a product defect.
- 45 **[0018]** Thirdly, there is a problem relating to an elongated and enlarged coil.
- [0019]** In the related art described in Patent Document 2, the buildup coil is formed, and the buildup coil has an elongated and enlarged form. When the coil is elongated and enlarged, the torque required of a reel for exerting a tension necessary for rolling by the reel is increased in the manner of linear proportionality to the coil outside diameter. This leads to an enlarged reel-driving device.
- 50 **[0020]** Fourthly, there is a problem relating to coil cutting.
- [0021]** Besides, in Patent Document 2, cold rolling equipment is proposed in which a buildup coil is cut up in the final pass to a coil size that permits carrying-out of coils. In this equipment, if only one winding device is used to winding the cut coil, the rolling speed at the time of cutting is 0 mpm. When the rolling speed becomes 0 mpm, rolling is stopped. Therefore, the coefficient of friction between the work roll and the strip is changed at the surface of the strip clamped between the work rolls, whereby stop marks are generated. In addition, the stop marks would be transferred also to the
- 55

work rolls. Consequently, in the subsequent rolling, the stop marks may be transferred to the strip surfaces at regular intervals corresponding to the rotational pitch of the work rolls. When the stop marks are generated in the first pass, the stop marks may be made so inconspicuous that they are visually imperceptible, due to the continuation of rolling a plurality of times. When the stop marks are generated in the final pass, however, they would spoil the quality of surface gloss, making the products defective in the case where the products are materials with rigorous quality requirements.

[0022] It is an object of the present invention to provide cold-rolled material manufacturing equipment and a cold rolling method by which a high efficiency, a high yield and a high investment cost-effectiveness are realized in a small- to medium-scale plant with a capacity of about 300,000 to 600,000 tons of product per year.

Means for Solving the Problems

[0023] A reversible cold rolling method according to a first invention for solving the above-mentioned first problem is a reversible cold rolling method for performing a plurality of passes of cold rolling while changing rolling direction by use of an unwinding device by which a coil is unwound, at least one reversible cold rolling mill, first and second winding/unwinding devices provided respectively on an entry side and an delivery side of a first pass of the cold rolling mill, and a joining device disposed between the unwinding device and the first winding/unwinding device, characterized in that the method includes: a rolling step of guiding a strip of a first coil unwound from the unwinding device directly to the cold rolling mill, rolling the strip and winding the rolled strip onto the second winding/unwinding device; a joining step of joining a tail end of the first coil and a leading end of a second coil subsequently unwound from the unwinding device, upon arrival of the tail end of the first coil at the joining device; a first-pass coil building-up and rolling step of repeating the rolling step and the joining step to perform the first-pass rolling by the cold rolling mill and the joining of the tail end of a preceding coil and the leading end of a succeeding coil by the joining device, from a subsequent second coil on, thereby building up a plurality of coils into one coil; a reversible rolling step of performing reversible rolling of the built-up coil a predetermined number of times until a desired product strip thickness is reached; and a cutting and winding step of cutting the built-up coil in a final pass of the reversible rolling step by a cutting device and winding the cut coils onto either of the first and second winding/unwinding devices to form a plurality of coils.

[0024] Meanwhile, in building up a plurality coils into one coil, rolling must be stopped during joining. When the stop of rolling, that is, rolling speed becomes 0 mpm, the coefficient of friction between the work roll and the strip is changed, with the result of formation of stop marks, at the surfaces of the strip clamped between the work rolls. Further, the stop marks would be transferred to the work rolls. During the subsequent rolling, therefore, the stop marks may be transferred to the strip surfaces at regular intervals corresponding to the rotational pitch of the work rolls. Where the stop marks are generated in the first pass, they may be made so inconspicuous that they are visually imperceptible, by continuation of the rolling a plurality of times. Where a high quality in regard of surface gloss is required rigorously, however, a problem that the strips with the stop marks are dealt with as defective products is newly generated.

[0025] The reversible cold rolling method according to a second invention for solving the just-mentioned newly generated problem is the reversible cold rolling method according to the first invention, characterized in that a strip storage device is provided between the cold rolling mill and the joining device, and the rolling speed during joining of the tail end of the preceding coil and the leading end of the succeeding coil in the joining step is set to be more than 0 mpm and not more than 50 mpm.

[0026] The reversible cold rolling method according to a third invention for solving the above-mentioned fourth problem is the reversible cold rolling method according to any one of the first and second inventions, characterized in that the rolling speed at the time of cutting the coil in the final pass in the cutting and winding step is set to be more than 0 mpm and not more than 50 mpm.

[0027] On the other hand, when the rolling speed at the time of joining and the rolling speed in cutting the coil in the final pass are lowered to a value of more than 0 mpm and not more than 50 mpm, a problem of a lowering in strip thickness control accuracy is newly generated. Specifically, a strip thickness meter used for strip thickness control is disposed at a distance from the work rolls of the rolling mill. When the rolling speed is lowered, therefore, a feedback control of strip thickness by use of measured values obtained from the strip thickness meter leads to a lowering in strip thickness control accuracy due to a time lag.

[0028] The reversible cold rolling method according to a fourth invention for solving the just-mentioned newly generated problem is the reversible cold rolling method according to any one of the first to third inventions, characterized in that in the joining step, entry-side rolling speed and entry-side strip thickness and delivery-side rolling speed at the cold rolling mill are measured, the strip thickness beneath work rolls of the cold rolling mill is computed based on the measured values, and a strip thickness control such as to obtain a desired strip thickness is performed by a hydraulic rolling reduction device possessed by the cold rolling mill.

[0029] Similarly, when the rolling speed at the time of joining and the rolling speed in cutting the coil in the final pass are lowered to a value of more than 0 mpm and not more than 50 mpm, a problem of lowering in shape control accuracy is newly generated. Specifically, like the strip thickness meter, a shape detector for measuring the shape of the strip is

also disposed at a distance from the work rolls of the rolling mill. When the rolling speed is lowered, therefore, time is taken after the recognition of strip shape by the shape detector until the correction of strip shape by an actuator, whereby shape control accuracy is lowered. Besides, a lowering in rolling speed generally raises the coefficient of friction between the strip and the work roll, resulting in a rise in rolling load, whereby the strip shape is disturbed.

5 [0030] The reversible cold rolling method according to a fifth invention for solving the just-mentioned newly generated problem is the reversible cold rolling method according to any one of the first to fourth inventions, characterized in that in the joining step and the cutting and winding step, strip shape is controlled by a roll bender control or a coolant control or a combination of both controls on the basis of the computation result of roll deflection due to fluctuations in rolling load at the cold rolling mill.

10 [0031] The reversible cold rolling method according to a sixth invention for solving the above-mentioned second problem is the reversible cold rolling method according to any one of the first to fifth inventions, characterized in that the order of feeding-in of coils to the unwinding device is preliminarily controlled so that the absolute value of a strip thickness difference between a preceding coil and a succeeding coil will be not more than 1 mm, prior to the rolling step.

15 [0032] The reversible cold rolling method according to a seventh invention for solving the above-mentioned first problem is the reversible cold rolling method according to any one of the first to sixth inventions, characterized in that joining is performed by use of a joining device of a mash seam welding system as the joining device, in the joining step.

20 [0033] On the other hand, when a joining device of a mash seam welding system is used, a problem relating to the joint portion is newly generated. Specifically, a mash seam welding machine adopts a system wherein the materials to be joined are lapped on each other and clamped between electrode wheels, and an electric current is passed through the materials to cause contact resistance and internal resistance heating of the materials, whereby the materials are joined together. As a result, the joint portion upon completion of the joining shows an increased strip thickness of about 1.2 to 1.5 times the original thickness. The increase in thickness causes the joint portion to constitute a step, so that an excessive force is exerted on the rolls when the step passes the rolling mill. Furthermore, the step may be transferred to the work rolls as marks. Thus, a problem similar to the second problem is generated.

25 [0034] The reversible cold rolling method according to an eighth invention for solving the just-mentioned problem that is similar to the second problem and is newly generated is the reversible cold rolling method according to any one of the first to seventh inventions, characterized in that a cross swaging treatment is performed immediately after the joining by the joining device of the mash seam welding system.

30 [0035] The reversible cold rolling method according to a ninth invention for solving the above-mentioned third problem is the reversible cold rolling method according to any one of the first to eighth inventions, characterized in that the outside diameter of the coil built up in the coil building-up and rolling step is set to be not more than $\phi 3000$.

35 [0036] The reversible cold rolling method according to a tenth invention for solving the above-mentioned third problem is the reversible cold rolling method according to any one of the first to ninth inventions, characterized in that a tension on a strip when a coil outside diameter is larger is gradually decreased as compared with a tension on the strip when the coil outside diameter is smaller.

[0037] The reversible cold rolling method according to an eleventh invention is the reversible cold rolling method according to any one of the first to tenth inventions, characterized in that in the reversible rolling step and the coil building-up and rolling step, rolling is performed by use of a two-stand cold rolling mill as the cold rolling mill.

40 [0038] The reversible cold rolling method according to a twelfth invention for solving the above-mentioned second problem is the reversible cold rolling method according to any one of the first to eleventh inventions, characterized in that in the cutting and winding step, coil cutting in the final pass is performed immediately after passage of a joint portion through the cutting device.

45 [0039] The reversible cold rolling method according to a thirteenth invention for solving the above-mentioned second problem is the reversible cold rolling method according to the twelfth invention, characterized in that in the cutting and winding step, coil cutting in the final pass is performed immediately before passage of a joint portion through the cutting device and immediately after the passage of the joint portion through the cutting device.

50 [0040] The reversible cold rolling method according to a fourteenth invention is the reversible cold rolling method according to any one of the first to thirteenth inventions, characterized in that work rolls are replaced by dulled work rolls in a condition where a strip is threaded the cold rolling mill, before start of final-pass rolling in the cutting and winding step, and the final-pass rolling is performed.

55 [0041] Reversible cold rolling equipment according to a fifteenth invention for solving the above-mentioned first problem is a reversible cold rolling equipment for performing a plurality of passes of cold rolling while changing a rolling direction, by use of an unwinding device by which a coil is unwound, at least one reversible cold rolling mill, first and second winding/unwinding devices provided respectively on an entry side and an delivery-side of a first pass of the cold rolling mill, and a joining device disposed between the unwinding device and the first winding/unwinding device, characterized in that the equipment includes a controller by which the unwinding device, the cold rolling mill, the first and second winding/unwinding devices, the joining device and cutting device are controlled so that: a strip of a first coil unwound from the unwinding device is guided directly to the cold rolling mill, is rolled and is wound onto the second winding/unwinding

device; a tail end of the first coil and a leading end of a second coil subsequently unwound from the unwinding device are joined upon arrival of the tail end of the first coil at the joining device; rolling and joining, for the second coil and following coils, are subsequently repeated to perform the first-pass rolling by the cold rolling mill and the joining of the tail end of a preceding coil and the leading end of a succeeding coil by the joining device, thereby building up a plurality of coils into one coil; reversible rolling of the built-up coil is performed at the cold rolling mill a predetermined number of times until a desired product strip thickness is reached; and the built-up coil is cut by a cutting device and the cut coils are wound onto either of the first and second winding/unwinding devices to form a plurality of coils.

[0042] The reversible cold rolling equipment according to a sixteenth invention for solving the problem newly generated attendantly on the above-mentioned first problem is the reversible cold rolling equipment according to the fifteenth invention, characterized in that a strip storage device is disposed between the joining device and the cold rolling mill.

[0043] The reversible cold rolling equipment according to a seventeenth invention for solving the problem newly generated attendantly on the above-mentioned first problem is the reversible cold rolling equipment according to any one of the fifteenth and sixteenth invention, characterized in that the length of a strip stored at the strip storage device is more than 0 m and not more than 100 m.

[0044] The reversible cold rolling equipment according to an eighteenth invention for solving the problem newly generated attendantly on the above-mentioned first problem is the reversible cold rolling equipment according to any one of the fifteenth to seventeenth inventions, characterized in that the controller controls rolling speeds at the cold rolling mill during coil joining by the joining device and at the time of coil cutting by the cutting device to a value of more than 0 mpm and not more than 50 mpm.

[0045] The reversible cold rolling equipment according to a nineteenth invention for solving the problem newly generated attendantly on the above-mentioned first problem is the reversible cold rolling equipment according to any one of the fifteenth to eighteenth inventions, characterized in that the controller performs a strip thickness control such that during coil joining by the joining device and at the time of coil cutting by the cutting device, entry-side rolling speed and entry-side strip thickness and delivery-side rolling speed at the cold rolling mill are measured, the strip thickness beneath work rolls of the cold rolling mill is computed based on the measured values, and a strip thickness control such as to obtain a desired strip thickness is performed by a hydraulic rolling reduction device possessed by the cold rolling mill.

[0046] The reversible cold rolling equipment according to a twentieth invention for solving the problem newly generated attendantly on the above-mentioned first problem is the reversible cold rolling equipment according to any one of the fifteenth to nineteenth inventions, characterized in that the controller controls strip shape by a roll bender control or a coolant control or a combination of both controls on the basis of the computation result of roll deflection due to fluctuations in rolling load at the cold rolling mill, during coil joining by the joining device and at the time of coil cutting by the cutting device.

[0047] The reversible cold rolling equipment according to a twenty-first invention for solving the above-mentioned third problem is the reversible cold rolling equipment according to any one of the fifteenth to twentieth inventions, characterized in that the controller sets a tension on a strip when a coil outside diameter is larger to be gradually lower as compared with a tension on the strip when the coil outside diameter is smaller, during the coil building-up and rolling in the first pass and the subsequent reversible rolling.

[0048] The reversible cold rolling equipment according to a twenty-second invention is the reversible cold rolling equipment according to any one of the fifteenth to twenty-first inventions, characterized in that the cold rolling mill is of a two-stand type.

[0049] The reversible cold rolling equipment according to a twenty-third invention for solving the above-mentioned second problem is the reversible cold rolling equipment according to any one of the fifteenth to twenty-second inventions, characterized in that the joining device is a mash seam welding machine.

[0050] The reversible cold rolling equipment according to a twenty-fourth invention for solving the above-mentioned second problem is the reversible cold rolling equipment according to the twenty-third invention, characterized in that the mash seam welding machine as the joining device includes a swaging roller having a mechanism for inclining a swaging roller axis relative to a horizontal plane perpendicular to a joining line.

Effects of the Invention

[0051] According to the present invention, the following effects can be obtained.

[0052] In the first invention and the fifteenth invention, the buildup coil is formed in the first pass, and reversible rolling of the buildup coil is conducted in the second and following passes, whereby the joint portion can also be rolled at a normal rolling speed, and production efficiency is enhanced, as compared with the related art described in Patent Document 1. In addition, an unrolled portion is generated only at an innermost circumferential portion and an outermost circumferential portion of the buildup coil, so that off-gage rate can be remarkably lowered. Further, there is little portion that is rolled at a non-steady rolling speed, so that strip thickness accuracy is enhanced. In other words, a high efficiency and a high yield comparable to those according to the related art described in Patent Document 2 can be maintained.

5 [0053] Besides, in the first pass, subsequent to the rolling of the first coil and the joining of the first coil and the second coil, rolling and joining for the second and following coils are repeated, and the rolling in the first pass by the cold rolling mill and the joining between the tail end of a preceding coil and the leading end of a succeeding coil by the joining device are conducted, thereby building up a plurality of coils into one coil. This eliminates the need for a buildup-coil winding/unwinding device, which is indispensable in the related art described in Patent Document 2. This makes it possible to simplify the equipment configuration and, as a result, to curtail the initial cost.

10 [0054] Meanwhile, in building up a plurality coils into one coil, rolling must be stopped during joining. When the stop of rolling, that is, rolling speed becomes 0 mpm, the coefficient of friction between the work roll and the strip is changed, with the result of formation of stop marks, at the surfaces of the strip clamped between the work rolls. Further, the stop marks would be transferred to the work rolls. During the subsequent rolling, therefore, the stop marks may be transferred to the strip surfaces at regular intervals corresponding to the rotational pitch of the work rolls. Where the stop marks are generated in the first pass, they may be made so inconspicuous that they are visually imperceptible, by continuation of the rolling a plurality of times. Where a high quality in regard of surface gloss is required rigorously, however, a problem that the strips with the stop marks are dealt with as defective products is newly generated.

15 [0055] In the second, sixteenth, seventeenth and eighteenth inventions, the strip storage device is provided between the cold rolling mill and the joining device, a strip is stored in the strip storage device at other times than the time of joining, whereas at the time of joining the strip stored in the strip storage device is used to continue rolling even in the condition where the tail end of a preceding coil is stopped. This ensures that stop marks can be prevented from being transferred from the work rolls to the strip during the joining operation.

20 [0056] Furthermore, the rolling speed during joining between the tail end of a preceding coil and the leading end of a succeeding coil is set to be more than 0 mpm and not more than 50 mpm, whereby it is ensured that when the time required for the joining operation is 2 minutes, for example, the length of the strip to be stored can be 100 m or less. Thus, the length of the strip to be stored in the strip storage device can be shortened, and the strip storage device can be made compact. As a result, equipment configuration can be simplified.

25 [0057] Preferably, the rolling speed is set to be more than 0 mpm and not more than 20 mpm, more preferably more than 0 mpm and not more than 10 mpm, and further preferably more than 0 mpm and not more than 5 mpm, whereby the length of the strip to be stored can be set to be not more than 40 m, not more than 20 m, and not more than 10 m, respectively. Thus, the length of the strip to be stored in the strip storage device can be shortened, and the strip storage device can be made compact. Consequently, equipment configuration can be made smaller.

30 [0058] In the third invention, the rolling speed in cutting the coil in the final pass is more than 0 mpm and not more than 50 mpm, and a collapsible type reel (described later) is applied. This ensures that an operation of extracting and carrying out a coil, after coil cutting, and subsequently winding the next coil can be conducted by use of a single winding/unwinding device. This makes it possible to eliminate the need for a winding/unwinding device with a solid block type reel and a winding device for the carrying-out operation, which are indispensable in the related art described in Patent Document 2. Accordingly, it is possible to simplify the equipment configuration and, as a result, to curtail the initial cost.

35 [0059] Preferably, the rolling speed is set to be more than 0 mpm and not more than 20 mpm, more preferably more than 0 mpm and not more than 10 mpm, and further preferably more than 0 mpm and not more than 5 mpm. By this setting, the distance between the cutting device and the winding/unwinding device can be shortened, and the equipment length can be shortened. As a result, initial investment expenditure can be curtailed.

40 [0060] In addition, by continuing rolling even at the time of cutting the coil, stop marks can be prevented from being transferred from the work rolls to the strip during the joining operation.

45 [0061] On the other hand, when the rolling speed during joining and the rolling speed at the time of cutting the coil in the final pass are lowered to a value of more than 0 mpm and not more than 50 mpm, a problem of a lowering in strip thickness control accuracy is newly generated. Specifically, a strip thickness meter used for strip thickness control is disposed at a distance from the work rolls of the rolling mill. When the rolling speed is lowered, therefore, a feedback control of strip thickness by use of measured values obtained from the strip thickness meter leads to a lowering in strip thickness control accuracy due to a time lag.

50 [0062] In order to solve the just-mentioned newly generated problem, in the fourth and nineteenth inventions, at the time of joining the entry-side rolling speed and the entry-side strip thickness and the delivery-side rolling speed at the cold rolling mill are measured, the strip thickness beneath the work roll of the cold rolling mill is computed based on the measured values, and a strip thickness control is conducted by a hydraulic rolling reduction device possessed by the cold rolling mill so that a desired strip thickness will be obtained. Therefore, the accuracy of strip thickness can be maintained.

55 [0063] Similarly, when the rolling speed during joining and the rolling speed at the time of cutting the coil in the final pass are lowered to a value of more than 0 mpm and not more than 50 mpm, a problem of lowering in shape control accuracy is newly generated. Specifically, like the strip thickness meter, a shape detector for measuring the shape of the strip is also disposed at a distance from the work rolls of the rolling mill. When the rolling speed is lowered, therefore, time is taken after the recognition of strip shape by the shape detector until the correction of strip shape by an actuator,

whereby shape control accuracy is lowered. Besides, a lowering in rolling speed generally raises the coefficient of friction between the strip and the work roll, resulting in a rise in rolling load, whereby the strip shape is disturbed.

5 [0064] In order to solve the just-mentioned new problem, in the fifth and twentieth inventions, during joining and at the time of cutting the coil in the final pass, strip shape is controlled by a roll bender control or a coolant control or a combination of both controls on the basis of the computation result of roll warpage due to fluctuations in the rolling load at the rolling mill. This makes it possible to compensate for the detection lag and to maintain the shape of the strip.

10 [0065] In the sixth invention, the order of feeding of coils into the unwinding device is preliminarily controlled so that the absolute value of a strip thickness difference between a preceding coil and a succeeding coil will be not more than 1 mm, more preferably not more than 0.5 mm. This makes it possible to restrain cracks from being transferred to the adjacent coil layers, due to the step present at the joint portion located at an inner layer portion of the buildup coil.

[0066] In the seventh and twenty-third inventions, joining is conducted by use of a joining device of a mash seam welding system that is inexpensive. This makes it possible to solve the problem relating to cost-effectiveness, in a small- to medium-scale plant with an annual output of about 300,000 to 600,000 tons.

15 [0067] On the other hand, when a joining device of a mash seam welding system is used, a problem relating to the joint portion is newly generated. Specifically, a mash seam welding machine adopts a system wherein the materials to be joined are lapped on each other and clamped between electrode wheels, and an electric current is passed through the materials to cause contact resistance and internal resistance heating of the materials, whereby the materials are joined together. As a result, the joint portion upon completion of the joining shows an increased strip thickness of about 1.2 to 1.5 times the original thickness. The increase in thickness causes the joint portion to constitute a step, so that an excessive force is exerted on the rolls when the step passes the rolling mill. Furthermore, the step may be transferred to the work rolls as marks.

20 [0068] In the eighth and twenty-fourth inventions, a cross swaging treatment for rolling the joint portion showing an increased strip thickness is conducted by inclining swaging rollers after the mash seam welding, whereby the step can be smoothened.

25 [0069] In the ninth invention, the coil outside diameter of the buildup coil after joining is set to be not more than $\phi 3000$. This ensures that a coil tightening force exerted on the coil can be restricted, and the winding/unwinding device can be restrained from being enlarged due to an enlargement in the coil outside diameter.

30 [0070] Furthermore, a collapsible type reel having an expansion/collapse function can be applied, instead of a solid block type reel not having an expansion/collapse function. Consequently, the number of winding/unwinding devices can be reduced, as above-mentioned.

[0071] In the tenth and twenty-first inventions, a tension control is performed by which the tension on a strip when the coil outside diameter is larger is gradually decreased as compared with the tension on the strip when the coil outside diameter is smaller. As a result of this, it is possible to limit the coil tightening force exerted on the coil, and to restrain the winding/unwinding device from being enlarged due to an enlargement of the coil outside diameter.

35 [0072] Further, a collapsible type reel can be applied, and the number of winding/unwinding devices can be reduced, as will be described later.

[0073] In the eleventh and twenty-second inventions, rolling is conducted by use of a two-stand type cold rolling mill. By this, the number of rolling passes required until a desired strip thickness is obtained can be reduced, and production efficiency is enhanced.

40 [0074] Meanwhile, while the problem relating to the joint portion is solved as above-mentioned, the product coils may be required to have a further accuracy.

[0075] In the twelfth invention, the coil cutting in the final pass is performed immediately after passage of the joint portion through the cutting device. By this, the joint portion can be disposed at the outer surface of the cut coil, and a treatment of the joint portion after coil extraction can be easily carried out.

45 [0076] In the thirteenth invention, coil cutting in the final pass is conducted immediately before passage of the joint portion through the cutting device and immediately after the passage of the joint portion through the cutting device. This ensures that the joint portion is not wound around the product coil, so that the need for an after-treatment of the joint portion can be eliminated.

50 [0077] In the fourteenth invention, the work rolls are replaced by dulled work rolls in a condition where a strip is passed through the cold rolling mill, before the start of the final-pass rolling, and then the final-pass rolling is conducted. This makes it possible to enhance malleability at the time of deep drawing conducted as a preparatory step for the cold rolling step, or the adhesion and sharpness relating to painting.

55 [0078] As above-described, it is possible to provide cold-rolled material manufacturing equipment and a cold rolling method by which a high efficiency, a high yield and a high investment cost-effectiveness are realized in a small- to medium-scale plant with an annual production of about 300,000 to 600,000 tons.

Brief Description of Drawings

[0079]

- 5 Fig. 1 is a schematic view of cold-rolled material equipment according to a first embodiment of the present invention.
 Fig. 2 is a control flow showing a procedure (first pass) executed by a controller.
 Fig. 3 is a control flow showing procedures (second and third passes) executed by the controller.
 Fig. 4 is a control flow showing a procedure (fourth pass) executed by the controller.
 Fig. 5 is a timetable (first pass) for each of devices.
 10 Fig. 6 is a timetable (second and third passes) for each of the devices.
 Fig. 7 is a timetable (fourth pass) for each of the devices.
 Fig. 8 is a schematic view of cold-rolled material equipment according to a first related art used for comparison.
 Fig. 9 is a schematic view of cold-rolled material equipment according to a second related art used for comparison.
 Fig. 10 is a conceptual illustration of a mash seam welding system.
 15 Fig. 11 is a schematic view of a joining device of the mash seam welding system.
 Fig. 12 is a schematic view of an inclining mechanism provided in the joining device.
 Fig. 13 is an illustration of metal flow at a joint portion.
 Fig. 14 shows illustrations of a first setting method for an angle of inclination of pressure rollers.
 Fig. 15 shows illustrations of a second setting method for the angle of inclination of the pressure rollers.
 20 Fig. 16 is a diagram showing a tension control at the time of winding a buildup coil 102.
 Fig. 17 is a schematic view of cold-rolled material equipment according to a second embodiment of the present invention.
 Fig. 18 is a schematic view of cold-rolled material equipment according to a third embodiment of the present invention.
 Fig. 19 is a control flow (first pass) showing a procedure executed by the controller.
 25 Fig. 20 is a schematic view of cold-rolled material equipment according to a fourth embodiment of the present invention.

Mode for Carrying Out the Invention

30 First Embodiment

[0080] Now, a first embodiment of the present invention will be described below, referring to the drawings. Description will be made of an exemplary case where the cold-rolled material in the present embodiment is a cold-rolled steel plate.

35 <Main Configuration>

[0081] Fig. 1 is a schematic view of cold-rolled material equipment according to the first embodiment of the present invention.

40 [0082] In Fig. 1, the cold-rolled material equipment according to the present embodiment includes, as main components: a reversible cold rolling mill 1; a unwinding device 2 for unwinding a strip of an input coil 101; a winding/unwinding device 3 (first winding/unwinding device) disposed on the entry side of a first pass of the cold rolling mill 1; a winding/unwinding device 4 (second winding/unwinding device) disposed on the delivery side of the first pass of the cold rolling mill 1; a joining device 5 disposed between the unwinding device 2 and the winding/unwinding device 4 so as to form a buildup coil 102 from a plurality of input coils 101; cutting devices 6 for cutting up the strip of the buildup coil 102 in a final pass to form output coils 103; and a controller 20 for controlling the cold rolling mill 1, the unwinding device 2, the winding/unwinding devices 3, 4, the joining device 5 and the cutting devices 6.

45 [0083] The reversible cold rolling mill 1 is, for example, a six-high UC mill which includes top and bottom work rolls 11, 11 which make direct contact with a work (material to be rolled) and roll the work, top and bottom intermediate rolls 12, 12 which support the work rolls in the vertical direction, and top and bottom back-up rolls 13, 13 which support the intermediate rolls 12, 12 in the vertical direction.
 50

[0084] A hydraulic rolling reduction device 14 is provided beneath the bottom back-up roll 13. Based on a command, the hydraulic rolling reduction device 14 moves a bearing for the bottom back-up roll 13 up or down, whereby a strip is reduced to obtain a predetermined rolling reduction. A load meter 15 is provided on the upper side of the top back-up roll 13, and the rolling reduction of the rolls is controlled correspondingly to a variation in load that is detected by the load meter 15. This series of operations is referred to as reduction control.
 55

[0085] Incidentally, a strip thickness meter 16a, a plate velocity meter 17a and a shape meter 18a are provided on the entry side of the first pass of the cold rolling mill 1, whereas a strip thickness meter 16b, a plate velocity meter 17b and a shape meter 18b are provided on the delivery side of the first pass of the cold rolling mill 1. These meters are

used for a strip thickness control and a shape control, and the reduction control is carried out based on the results of these controls.

[0086] The unwinding device 2 includes a collapsible type reel having an expansion/collapse function, sets the input coil 101, and unwinds a strip of the input coil 101.

[0087] The winding/unwinding device 3 and the winding/unwinding device 4 each include a collapsible type reel having an expansion/collapse function. Winding and unwinding of a work are repeatedly conducted between the winding/unwinding device 3 and the winding/unwinding device 4, whereby a plurality of passes of cold rolling are carried out while changing the rolling direction.

[0088] The joining device 5 joins the tail end of the strip of a first input coil 101a already unwound with the leading end of the strip of a second input coil 101b subsequently unwound, and subsequently and similarly joins the tail end of the strip of the second input coil 101b with the leading end of the strip of a third input coil 101c, to form a buildup coil 102.

[0089] The cutting device 6a is disposed between the cold rolling mill 1 and the winding/unwinding device 3, and cuts up the strip of the buildup coil 102 in a pass in which the winding in the final pass is completed at the winding/unwinding device 3. In addition, the cutting device 6b is disposed between the cold rolling mill 1 and the winding/unwinding device 4, and cuts up the strip of the buildup coil 102 in a pass in which the winding is completed at the winding/unwinding device 4.

<Main Control>

[0090] Figs. 2 to 4 are control flows showing the procedures executed by the controller 20. Dotted lines indicate relationships among the devices 1 to 6. A control in the case where a buildup coil 102 is formed from three input coils 101 and where four passes of rolling are conducted will be described. Figs. 5 to 7 are timetables for each of the devices 1 to 6 corresponding to the control flows, and the same step numbers as in Figs. 2 to 4 are given to those parts of the timetables which correspond to the procedure steps (relevant to the step numbers) in the control flows.

[0091] A main control in the first pass will be described referring to Fig. 2.

[0092] The controller 20 controls the cold rolling mill 1 in the following manner. When a first input coil 101a is fed in and mounted onto the unwinding device 2 and a strip thereof is unwound, the strip of the first input coil 101a is threaded the cold rolling mill 1 (S1101) and is fed further to the winding/unwinding device 4. When the leading end of the strip of the first input coil 101a is gripped by the winding/unwinding device 4, the cold rolling mill 1 is subjected to a reduction control (S1102). When preparation for rolling is completed in this way, acceleration to a steady rolling speed is conducted, and rolling is carried out at a steady rolling speed (S1103). Here, the steady rolling speed means a maximum speed at which the capability of the cold rolling mill can be exhibited to the utmost, in obtaining a desired strip thickness. The steady rolling speed in reversible cold rolling equipment is generally in the range of 400 to 1400 mpm.

[0093] According to a procedure in which the tail end of the strip of the first input coil 101a is unwound from the unwinding device 2 and a second input coil 101b is fed into the unwinding device 2, the cold rolling mill 1 is decelerated and the rolling is stopped (S1104). When the first input coil 101a and the second input coil 101b are joined, acceleration to the steady rolling speed is again conducted, the cold rolling mill 1 rolls an unrolled strip of the first input coil 101a at the steady rolling speed (S1105), and, in succession, rolls the joined second input coil 101b at the steady rolling speed (S1106). According to a procedure in which the second input coil 101b is unwound from the unwinding device 2 and a third input coil 101c is fed into the unwinding device 2, the cold rolling mill 1 is decelerated and rolling is stopped (S1107). When the second input coil 101b and the third input coil 101c are joined, acceleration to the steady rolling speed is again conducted, the cold rolling mill 1 rolls an unrolled portion of the second input coil 101b at the steady rolling speed (S1108), and, in succession, rolls the third input coil 101c at the steady rolling speed (S1109). When the tail end of the strip of the third input coil 101c is unwound from the unwinding device 2 and fed out, the cold rolling mill 1 is decelerated, and, when the tail end of the strip of the third input coil 101c reaches a position immediately upstream of the cold rolling mill 1, the cold rolling mill 1 stops rolling (S1110), and the first pass of rolling is finished (S1111).

[0094] The controller 20 controls the unwinding device 2 as follows. When the first input coil 101a is fed into and mounted onto the unwinding device 2 (S1201), the unwinding device 2 unwinds the strip of the first input coil 101a at a threading speed (S1202). Then, when the strip of the first input coil 101a is threaded the cold rolling mill 1 and gripped by the winding/unwinding device 4, the unwinding device 2 unwinds the strip of the first input coil 101a according to the rolling speed of the cold rolling mill 1 which is rolling at the steady rolling speed (S1203). Here, the threading speed means a speed of not more than 30 mpm, in general. When the unwinding device 2 unwinds the tail end of the strip of the first input coil 101a and the second input coil 101b is fed into and mounted onto the unwinding device 2 (S1204), the unwinding device 2 unwinds the strip of the second input coil 101b at the threading speed to the joining device 5 (S1205). Then, when the leading end of the strip of the second input coil 101b is fed out to a joining position of the joining device 5, the unwinding device 2 stops unwinding (S1206). When the first input coil 101a and the second input coil 101b are joined, the unwinding device 2 unwinds the remaining strip of the second input coil 101b according to the rolling speed of the cold rolling mill 1 which is rolling at the steady rolling speed (S1207). When the unwinding device 2 unwinds the tail end of the strip of the second input coil 101b and a third input coil 101c is fed into and mounted onto the unwinding

device 2 (S1208), the unwinding device 2 unwinds the strip of the third input coil 101c at the threading speed to the joining device 5 (S1209). Then, when the leading end of the strip of the third input coil 101c is fed out to the joining position of the joining device 5, the unwinding device 2 stops unwinding (S1210). When the second input coil 101b and the third input coil 101c are joined, the unwinding device 2 in succession unwinds the remaining strip of the third input coil 101c according to the rolling speed of the cold rolling mill 1 which is rolling at the steady rolling speed (S1211). When the tail end of the strip of the third input coil 101c is unwound from the unwinding device 2, the unwinding device 2 stops operating (S1212).

[0095] The controller 20 controls the winding/unwinding device 4 (second winding/unwinding device) in the following manner. When the strip of the first input coil 101a is fed out from the unwinding device 2 to be threaded the rolling mill and fed out further to the winding/unwinding device 4, the winding/unwinding device 4 grips the leading end of the strip of the first input coil 101a (S1401). According to the rolling speed of the cold rolling mill 1 which is rolling at the steady rolling speed, the winding/unwinding device 4 winds the strip of the first input coil 101a (S1402), and, according to the procedure of stopping the rolling of the strip of the first input coil 101a, the winding/unwinding device 4 is decelerated and stops winding (S1403). When the first input coil 101a and the second input coil 101b are joined, the winding/unwinding device 4 winds the remaining strip of the first input coil 101a according to the rolling speed of the cold rolling mill 1 which is rolling at the steady rolling speed (S1404), and, in succession, winds the strip of the second input coil 101b having been joined (S1405). According to the procedure of stopping the rolling of the strip of the second input coil 101b at the time of feeding in the third input coil 101c, the winding/unwinding device 4 is decelerated and stops winding (S1406). When the second input coil 101b and the third input coil 101c are joined, the winding/unwinding device 4 winds the remaining strip of the second input coil 101b according to the rolling speed of the cold rolling mill 1 which is rolling at the steady rolling speed (S1407), and, in succession, the winding/unwinding device 4 winds the strip of the third input coil having been joined (S1408). When the tail end of the strip of the third input coil 101c reaches a position immediately upstream of the cold rolling mill 1, the winding/unwinding device 4 stops winding (S1409). In this condition, the buildup coil 102 is formed from the three coils 101a, 101b and 101c (S1410). Incidentally, the outside diameter of the buildup coil 102 is not more than $\phi 3000$.

[0096] The controller 20 controls the joining device 5 as follows. When the tail end of the strip of the first input coil 101a reaches and is stopped at the joining position and the leading end of the second input coil 101b is fed out to the joining position, the joining device 5 joins the first input coil 101a and the second input coil 101b (S1501). Thereafter, when the tail end of the strip of the second input coil 101b reaches and is stopped at the joining position and the leading end of the strip of the third input coil 101c is fed out to the joining position of the joining device 5, the joining device 5 joins the second input coil 101b and the third input coil 101c (S1502).

[0097] Incidentally, the winding/unwinding device 3 (first winding/unwinding device) and the cutting devices 6a, 6b are not particularly controlled in the first pass.

[0098] A main control in the second pass and the third pass will be described referring to Fig. 3.

[0099] The controller 20 controls the cold rolling mill 1 as follows. When the tail end of the strip of the buildup coil 102 stopped at a position immediately upstream of the cold rolling mill 1 in the first pass is fed out in the reverse direction to that in the first pass to the winding/unwinding device 3 and the strip end is gripped by the winding/unwinding device 3, the cold rolling mill 1 is subjected to a reduction control (S2101). When the preparation for rolling is completed, the cold rolling mill 1 is accelerated to the steady rolling speed in the reverse direction to that in the first pass, and performs second-pass rolling at the steady rolling speed (S2102). When the strip of the buildup coil 102 is unwound from the winding/unwinding device 4 with its end gripped by the winding/unwinding device 4, the cold rolling mill 1 is decelerated and stopped (S2103), whereby the second-pass rolling is finished (S2104). Thereafter, before the start of third-pass rolling, the cold rolling mill 1 is subjected to a reduction control such as to obtain a desired strip thickness (S3101). When the preparation for rolling is completed, the cold rolling mill 1 is accelerated to the steady rolling speed in the reverse direction to that in the second pass, and performs the third-pass rolling at the steady rolling speed (S3102). When the strip of the buildup coil 102 is unwound from the winding/unwinding device 3 with its end gripped by the winding/unwinding device 3, the cold rolling mill 1 is decelerated and stopped (S3103), whereby the third-pass rolling is finished (S3104).

[0100] The controller 20 controls the winding/unwinding device 3 (first winding/unwinding device) in the following way. When the tail end of the strip of the buildup coil 102 stopped at a position immediately upstream of the cold rolling mill 1 in the first pass is fed out in the reverse direction to that in the first pass to the winding/unwinding device 3, the winding/unwinding device 3 grips the strip end (S2301). According to the rolling speed of the cold rolling mill 1 which is rolling at the steady rolling speed, the winding/unwinding device 3 winds the strip of the buildup coil 102 (S2302), and, according to the finishing of the second-pass rolling, the winding/unwinding device 3 is decelerated and stopped (S2303). Thereafter, according to the rolling speed of the cold rolling mill 1 which is rolling at the steady rolling speed, the winding/unwinding device 3 unwinds the strip of the buildup coil 102 (S3301), and, according to the finishing of the third-pass rolling, the winding/unwinding device 3 is decelerated and stopped (S3302).

[0101] The controller 20 controls the winding/unwinding device 4 (second winding/unwinding device) as follows. The winding/unwinding device 4 unwinds the strip of the buildup coil 102 at the threading speed in the reverse direction as

that in the first pass to the winding/unwinding device 3 (S2401). When the preparation for second-pass rolling is completed, the winding/unwinding device 4 unwinds the strip of the buildup coil 102 according to the rolling speed of the cold rolling mill 1 which is rolling at the steady rolling speed (S2402), and is decelerated and stopped according to the finishing of the second-pass rolling (S2403). Thereafter, according to the third-pass rolling speed of the cold rolling mill 1 which is rolling at the steady rolling speed in the reverse direction to that in the second pass, the winding/unwinding device 4 winds the strip of the buildup coil 102 (S3401), and, according to the finishing of the third-pass rolling, the winding/unwinding device 4 is decelerated and stopped (S3402).

[0102] Incidentally, the unwinding device 2, the joining device 5 and the cutting devices 6a, 6b are not particularly controlled in the second and third passes.

[0103] A main control in the fourth pass (final pass) will be described referring to Fig. 4. In the fourth pass (final pass), the buildup coil is cut up into three output coils 103a to 103c.

[0104] The controller 20 controls the cold rolling mill 1 in the following manner. After the third-pass rolling is finished and before fourth-pass rolling is started, the cold rolling mill 1 is subjected to a reduction control such as to obtain a desired strip thickness (S4101). When the preparation for rolling is completed, the cold rolling mill 1 is accelerated to a steady rolling speed in the reverse direction to that in the third pass, and the fourth-pass (final-pass) rolling is conducted at the steady rolling speed (S4102). According to the procedure in which the strip of the buildup coil 102 is cut by the cutting device 6a and the first output coil 103a is fed out from the winding/unwinding device 3, the cold rolling mill 1 is decelerated, and performs rolling at a low speed (for example, 10 mpm) (S4103). When the preparation for winding of the remaining strip (corresponding to the second input coil 103b) is completed, the cold rolling mill 1 is again accelerated to the steady rolling speed, and performs rolling of an unrolled strip for final pass of the buildup coil 102 (S4104). Then, according to the procedure in which the strip of the buildup coil 102 is cut by the cutting device 6a and the second output coil 103b is fed out from the winding/unwinding device 3, the cold rolling mill 1 is decelerated and performs rolling at a low speed (for example, 10 mpm) (S4105). When the preparation for winding of the remaining strip (corresponding to the third input coil 103c) is completed, the cold rolling mill 1 is again accelerated to the steady rolling speed, and performs rolling of an unrolled strip for final pass of the buildup coil 102 at the steady rolling speed (S4106). According to the procedure in which the strip of the buildup coil 102 is cut by the cutting device 6a and the third output coil 103c is fed out by the winding/unwinding device 3, the cold rolling mill 1 is decelerated, and performs rolling at a low speed (for example, 10 mpm) (S4107). When the third output coil 103c is cut off from the strip of the buildup coil 102 by the cutting device 6a, the cold rolling mill 1 stops rolling (S4108), whereby the fourth-pass (final-pass) rolling is finished (S4109).

[0105] The controller 20 controls the winding/unwinding device 3 (first winding/unwinding device) as follows. According to the rolling speed in the fourth pass (final pass) of the cold rolling mill 1 which is rolling at a steady rolling speed, the winding/unwinding device 3 winds the strip of the buildup coil 102 (S4301). When the strip is wound by a predetermined length, the winding/unwinding device 3 winds the strip of the buildup coil 102 according to the rolling speed of the cold rolling mill 1 which is rolling at a low speed (for example, 10 mpm) in conformity with the procedure of cutting (S4302). After the first output coil 103a is cut off, the winding/unwinding device 3 winds the remaining strip at a high speed (S4303), and, after the winding is completed, the winding/unwinding device 3 extracts the first output coil 103a and carries it out (S4304). The leading end of the strip fed out subsequently (the leading end of the second input coil 103b) is wound by a belt wrapper (S4305). When the preparation for winding is completed, the winding/unwinding device 3 winds the strip of the buildup coil 102 according to the rolling speed in the fourth pass (final pass) of the cold rolling mill 1 which is rolling at a steady rolling speed (S4306). When the strip is wound by a predetermined length, the winding/unwinding device 3 winds the strip of the buildup coil 102 according to the rolling speed of the cold rolling mill 1 which is rolling at a low speed (for example, 10 mpm) in conformity with the procedure of cutting (S4307). After the second output coil 103b is cut off, the winding/unwinding device 3 winds the remaining strip at a high speed (S4308). After the winding is completed, the winding/unwinding device 3 extracts the second output coil 103b and carries it out (S4309). The leading end of the strip fed out subsequently (the leading end of the third input coil 103c) is wound by the belt wrapper (S4310). When the preparation for winding is completed, the winding/unwinding device 3 winds the strip of the buildup coil 102 according to the rolling speed in the fourth pass (final pass) of the cold rolling mill 1 which is rolling at the steady rolling speed (S4311). When the strip is wound by a predetermined length, the winding/unwinding device 3 winds the strip of the buildup coil 102 according to the rolling speed of the cold rolling mill 1 which is rolling at a low speed (for example, 10 mpm) in conformity with the procedure of cutting (S4312). After the third output coil 103b is cut off, the winding/unwinding device 3 winds the remaining strip at a high speed (S4313). After the winding is completed, the winding/unwinding device 3 extracts the third output coil 103c and carries it out (S4314).

[0106] The controller 20 controls the winding/unwinding device 4 (second winding/unwinding device) in the following way. According to the rolling speed in the fourth pass (final pass) of the cold rolling mill 1 which is rolling at a steady rolling speed, the winding/unwinding device 4 unwinds the strip of the buildup coil 102 (S4401). When the strip is unwound by a predetermined length, the winding/unwinding device 4 unwinds the strip of the buildup coil 102 according to the rolling speed of the cold rolling mill 1 which is rolling at a low speed (for example, 10 mpm) in conformity with the procedure of cutting (S4402). Thereafter, according to the rolling speed of the cold rolling mill 1 which is again rolling at the steady

rolling speed, the winding/unwinding device 4 unwinds the strip of the buildup coil 102 (S4403). When the strip is unwound by a predetermined length, the winding/unwinding device 4 unwinds the strip of the buildup coil 102 according to the rolling speed of the cold rolling mill 1 which is rolling at a low speed (for example, 10 mpm) in conformity with the procedure of cutting (S4404). Thereafter, the winding/unwinding device 4 unwinds the strip of the buildup coil 102 according to the rolling speed of the cold rolling mill 1 which is again rolling at the steady rolling speed (S4405). When the strip is unwound by a predetermined length, the winding/unwinding device 4 unwinds the strip of the buildup coil 102 according to the rolling speed of the cold rolling mill 1 which is rolling at a low speed (for example, 10 mpm) in conformity with the procedure of cutting (S4406). After the third output coil 103b is cut off, the winding/unwinding device 4 winds the remaining strip, then extracts an off-gage coil 103d and carries it out (S4407).

[0107] The controller 20 controls the cutting device 6a in the following manner. The controller 20 computes each of cutting positions from coil outside diameters and reel rotational speeds at the winding/unwinding devices 3 and 4. The cutting device 6a cuts the first output coil 103a off the strip of the buildup coil 102 at a cutting position (S4601), then cuts the second output coil 103b off the remaining strip at the next cutting position (S4602), and further cuts the third output coil 103c off the remaining strip at a cutting position (S4603).

[0108] While the controller 20 computes the cutting positions on the basis of the coil outside diameters and reel rotational speeds in the present embodiment, a method may also be adopted in which boring or the like is applied to the cutting positions and the cutting positions are detected by a cutting position detector (not shown) or the like. Besides, another method may be adopted in which the distance measuring function of the plate velocity meter is used and the cutting positions are grasped through computation of distances.

[0109] Incidentally, the unwinding device 2, the joining device 5 and the cutting device 6b are not particularly controlled in the fourth pass (final pass).

<Main Operation>

[0110] The operation of the cold-rolled material equipment according to the present embodiment will be described. Description will be made of the operation in the case where the buildup coil 102 is formed from three input coils 101, four passes of rolling are conducted, and three input coils 103 are formed.

First Pass

[0111] When the first input coil 101a is fed into and mounted onto the unwinding device 2, the strip of the first input coil 101a is unwound at a threading speed, is threaded through the cold rolling mill 1, is gripped by the winding/unwinding device 4, and is wound further by a several-turn amount. Thereafter, the cold rolling mill 1 is subjected to a reduction control (S1201 → S1202 → S1101 → S1401 → S1102).

[0112] When the preparation for first-pass rolling is completed, the strip of the first input coil 101a is rolled at a steady rolling speed by the cold rolling mill 1, and is wound by the winding/unwinding device 4 while being unwound from the unwinding device 2 according to the rolling speed of the cold rolling mill 1 (S1203 → S1103 → S1402). When the controller 20 commands a rolling speed of the cold rolling mill 1, the cold rolling mill 1 is subjected to a feedback control such as to attain a command rolling speed. In addition, the unwinding device 2 is subjected to a strip feedback control such that the tension on the strip between the unwinding device 2 and the cold rolling mill 1 will be a predetermined value. Furthermore, the winding/unwinding device 4 is also subjected to a tension feedback control such that the tension on the strip between the winding/unwinding device 4 and the cold rolling mill 1 will be a predetermined value.

[0113] When the strip of the first input coil 101a is unwound from the unwinding device 2 and the tail end of the strip of the first input coil 101a reaches and is stopped at the joining position of the joining device 5, the cold rolling mill 1 and the unwinding device 2 and the winding/unwinding device 4 are stopped, and the second input coil 101b is fed into and mounted onto the unwinding device 2 (S1204 → S1104 → S1403).

[0114] In the condition where the cold rolling mill 1 and the winding/unwinding device 4 are stopped, the strip of the second input coil 101b is unwound from the unwinding device 2 at a threading speed. When the leading end of the strip is fed out to the joining position of the joining device 5, the strip is stopped, and the tail end of the strip of the first input coil 101a and the leading end of the strip of the second input coil 101b are joined by the joining device 5 (S1205 → S1206 → S1501).

[0115] When the first input coil 101a and the second input coil 101b are joined, rolling by the cold rolling mill 1 at the steady rolling speed is again conducted to roll an unrolled strip of the first input coil 101a, and, in succession, the strip of the second input coil 101b having been joined is rolled at the steady rolling speed by the cold rolling mill 1. According to the rolling speed of the cold rolling mill 1, the strip is unwound from the unwinding device 2 and wound by the winding/unwinding device 4 (S1105 → S1404 → S1207 → S1106 → S1405).

[0116] When the strip of the second input coil 101b is unwound from the unwinding device 2 and the tail end of the strip of the second input coil 101b reaches and is stopped at the joining position of the joining device 5, the cold rolling

mill 1 and the unwinding device 2 and the winding/unwinding device 4 are stopped, and the third input coil 101c is fed into and mounted onto the unwinding device 2 (S1208 → S1107 → S1406).

[0117] In the condition where the cold rolling mill 1 and the winding/unwinding device 4 are stopped, the strip of the third input coil 101c is unwound from the unwinding device 2 at a threading speed. When the leading end of the strip is fed out to the joining position of the joining device 5, the strip is stopped, and the tail end of the strip of the second input coil 101b and the leading end of the strip of the third input coil 101c are joined by the joining device 5 (S1209 → S1210 → S1502).

[0118] When the second input coil 101b and the third input coil 101cb are joined, rolling by the cold rolling mill 1 at the steady rolling speed is again performed to roll an unrolled strip of the second input coil 101b, and, in succession, the strip of the third input coil 101b having been joined is rolled at the steady rolling speed by the cold rolling mill 1. According to the rolling speed of the cold rolling mill 1, the strip is unwound from the unwinding device 2 and is wound by the winding/unwinding device 4 (S1108 → 1407 → S1211 → S1109 → S1408).

[0119] When the strip of the third input coil 101c is unwound, the unwinding device 2 is stopped. When the tail end of the strip of the third input coil 101c reaches a position immediately upstream of the cold rolling mill 1, the cold rolling mill 1 is stopped to finish the first pass, and the winding/unwinding device 4 is stopped according to the stopping of the cold rolling mill 1 (S1212 → S1110 → S1111 → S1409).

[0120] As a result, the buildup coil 102 is formed at the winding/unwinding device 4 (S1410).

Second and Third Passes

[0121] After the first pass is finished, the rolling direction is changed over to the reverse direction, and the second pass is started.

[0122] The strip of the buildup coil 102 is unwound from the winding/unwinding device 4 at a threading speed, the tail end of the strip is gripped by the winding/unwinding device 3, and the strip is further wound by a several-turn amount. Thereafter, the cold rolling mill 1 is subjected to a reduction control (S2401 → S2301 → S2101).

[0123] When the preparation for second-pass rolling is completed, the strip of the buildup coil 102 is rolled at a steady rolling speed by the cold rolling mill 1, and is wound by the winding/unwinding device 3 while being unwound from the winding/unwinding device 4 according to the rolling speed of the cold rolling mill 1 (S2402 → S2102 → S2302). When the strip of the buildup coil 102 is unwound by a predetermined length, the cold rolling mill 1 is stopped to finish the second pass, and the winding/unwinding device 3 and the winding/unwinding device 4 are stopped according to the stopping of the cold rolling mill 1 (S2103 → S2403 → S2303 → S2104).

[0124] After the second pass is finished, the rolling direction is changed over to the reverse direction, and the third pass is started.

[0125] In the condition where the strip of the buildup coil 102 is gripped by the winding/unwinding device 4 and the winding/unwinding device 3, the cold rolling mill 1 is subjected to a reduction control, the strip of the buildup coil 102 is rolled by the cold rolling mill 1 at a steady rolling speed, and the strip is wound by the winding/unwinding device 4 while being unwound from the winding/unwinding device 3 according to the rolling speed of the cold rolling mill 1 (S3101 → S3102 → S3301 → S3401). When the strip of the buildup coil 102 is unwound by a predetermined length, the cold rolling mill 1 is stopped to finish the third pass, and the winding/unwinding device 3 and the winding/unwinding device 4 are stopped according to the stopping of the cold rolling mill 1 (S3103 → S3302 → S3402 → S3104).

Fourth Pass

[0126] After the third pass is finished, the rolling direction is changed over to the reverse direction, and the fourth pass is started.

[0127] In the condition where the strip of the buildup coil 102 is gripped by the winding/unwinding device 4 and the winding/unwinding device 3, the cold rolling mill 1 is subjected to a reduction control, and the strip of the buildup coil 102 is rolled by the cold rolling mill 1 at a steady rolling speed. The strip of the buildup coil 102 is wound by the winding/unwinding device 3 while being unwound from the winding/unwinding device 4 according to the rolling speed of the cold rolling mill 1 (S4101 → S4102 → S4301 → S4401).

[0128] Immediately before the strip corresponding to the first output coil 103a is wound onto the winding/unwinding device 3, the cold rolling mill 1 is decelerated to a predetermined low speed, and the strip of the buildup coil 102 is rolled at the low speed (for example, 10 mpm) by the cold rolling mill 1. The strip of the buildup coil 102 is wound onto the winding/unwinding device 3 while being unwound from the winding/unwinding device 4 according to the rolling speed of the cold rolling mill 1 (S4103 → S4302 → S4402).

[0129] In the condition where the strip is wound onto the winding/unwinding device 3 at a low speed, the strip of the buildup coil 102 is cut at the strip cutting position by the cutting device 6a, and the remaining strip of the first output coil 103a thus cut is wound onto the winding/unwinding device 3 at a high speed. When the strip is wound, the winding/

unwinding device 3 is stopped, and the first output coil 103a is extracted from the winding/unwinding device 3 and carried out (S4601 → S4303 → S4304). Incidentally, a collapsible type reel is applied to the winding/unwinding device 3, as above-mentioned.

5 [0130] During when the first output coil 103a is carried out, also, the remaining strip of the buildup coil 102 having undergone cutting is rolled at a low speed by the cold rolling mill 1, and is unwound from the winding/unwinding device 4 according to the rolling speed of the cold rolling mill 1. The leading end of the strip (corresponding to the second input coil 103b) thus fed out is wound by a belt wrapper of the winding/unwinding device 3 (S4305).

10 [0131] When the preparation for winding at the winding/unwinding device 3 is completed, the remaining strip of the buildup coil 102 is rolled by the cold rolling mill 1 at a steady rolling speed, and is wound onto the winding/unwinding device 3 while being unwound from the winding/unwinding device 4 according to the rolling speed of the cold rolling mill 1 (S4104 → S4306 → S4403).

15 [0132] Immediately before the strip corresponding to the second output coil 103b is wound onto the winding/unwinding device 3, the cold rolling mill 1 is decelerated to a predetermined low speed. The strip of the buildup coil 102 is rolled by the cold rolling mill 1 at the low speed, and is wound onto the winding/unwinding device 3 while being unwound from the winding/unwinding device 4 according to the rolling speed of the cold rolling mill 1 (S4105 → S4307 → S4404).

20 [0133] In the condition where the strip is wound onto the winding/unwinding device 3 at a low speed, the strip of the buildup coil 102 is cut at a strip cutting position by the cutting device 6a, and the remaining strip of the second output coil 103b thus cut off is wound onto the winding/unwinding device 3 at a high speed. When the strip is wound, the winding/unwinding device 3 is stopped, and the second output coil 103b is extracted from the winding/unwinding device 3 and is carried out (S4602 → S4308 → S4309).

25 [0134] During when the second output coil 103b is carried out, also, the remaining strip of the buildup coil 102 having undergone cutting is rolled at a low speed by the cold rolling mill 1, and is unwound from the winding/unwinding device 4 according to the rolling speed of the cold rolling mill 1. The leading end of the strip (corresponding to the third input coil 103c) thus fed out is wound by a belt wrapper of the winding/unwinding device 3 (S4310).

30 [0135] When the preparation for winding at the winding/unwinding device 3 is completed, the remaining strip of the buildup coil 102 is rolled at a steady rolling speed by the cold rolling mill 1, and is wound onto the winding/unwinding device 3 while being unwound from the winding/unwinding device 4 according to the rolling speed of the cold rolling mill 1 (S4106 → S4311 → S4405).

35 [0136] Immediately before the strip corresponding to the third output coil 103c is wound onto the winding/unwinding device 3, the cold rolling mill 1 is decelerated to a predetermined low speed, and the strip of the buildup coil 102 is rolled by the cold rolling mill 1 at the low speed. The strip of the buildup coil 102 is wound onto the winding/unwinding device 3 while being unwound from the winding/unwinding device 4 according to the rolling speed of the cold rolling mill 1 (S4107 → S4312 → S4406).

40 [0137] In the condition where the strip is wound onto the winding/unwinding device 3 at a low speed, the strip of the buildup coil 102 is cut at a strip cutting position by the cutting device 6a, and the remaining strip of the third output coil 103c thus cut off is wound onto the winding/unwinding device 3 at a high speed. When the strip is wound, the winding/unwinding device 3 is stopped, and the third output coil 103c is extracted from the winding/unwinding device 3 and is carried out (S4603 → S4313 → S4314).

45 [0138] When the third output coil 103c is cut off, the cold rolling mill 1 stops rolling, to finish the fourth pass, and the remaining strip of the buildup coil 102 thus cut is wound onto the winding/unwinding device 4. The off-gage coil 103d thus wound is extracted from the winding/unwinding device 4 and is carried out (S4108 → S4109 → S4407). Incidentally, a collapsible type reel is applied to the winding/unwinding device 4, as above-mentioned.

50 [0139] As a result, the output coils 103a to 103c are carried out from the winding/unwinding device 3, whereas the off-gage coil 103d is carried out from the winding/unwinding device 4. Incidentally, in the case where the final pass is an odd-numbered pass, the strip of the buildup coil 102 is cut by the cutting device 6b, the output coils 103a to 103c are extracted from the winding/unwinding device 4 and is carried out, whereas the off-gage coil 103d is carried out from the winding/unwinding device 3.

55 [0140] Incidentally, while the steady rolling speeds in the first to fourth passes have been described without discrimination from one another for convenience of description, the steady rolling speed increases because the strip thickness decreases as the rolling is repeated, as is apparent from the timetables shown in Figs. 5 to 7.

<Main Effect>

[0141] The effects of the present embodiment will be described by comparison with a first related art and a second related art.

[0142] Fig. 8 is a schematic view of cold-rolled material equipment according to the first related art. The same components as those in Fig. 1 are denoted by the same reference symbols as used above.

[0143] In Fig. 8, the cold-rolled material equipment (RCM equipment) according to the first related art includes, as

main components: a reversible cold rolling mill 1; a unwinding device 2 for unwinding a strip to the cold rolling mill 1 in a first pass; a winding/unwinding device 3 disposed on the entry side of the first pass of the cold rolling mill 1; the winding/unwinding device 4 disposed on the delivery side of the first pass of the cold rolling mill 1; and a controller 20 for controlling the cold rolling mill 1, the unwinding device 2, and the winding/unwinding devices 3, 4.

5 **[0144]** Description will be made of an operation in the case where three input coils 101 are rolled in four passes by the cold-rolled material equipment according to the first related art.

[0145] An input coil 101a is fed into the unwinding device 2, the leading end of the strip of the input coil 101a that is threaded the cold rolling mill 1, is gripped by the winding/unwinding device 4, and is wound further by a several-turn amount. When the preparation for rolling, such as application of a tension and a reduction control, is completed, a first pass of rolling is started by the cold rolling mill 1. When the tail end of the strip reaches a position immediately upstream of the cold rolling mill 1, the first-pass rolling is finished.

10 **[0146]** Thereafter, the leading end of the strip is threaded the cold rolling mill 1 in the reverse direction as that in the first pass, the leading end is gripped by the winding/unwinding device 3, and the strip is wound further by a several-turn amount. After the preparation for rolling, such as application of a tension and a reduction control, is completed, a second pass of rolling is started by the cold rolling mill 1. In the condition where the strip end portion is wound onto the winding/unwinding device 3 by a several-turn amount, the second-pass rolling is finished.

15 **[0147]** After the preparation for a third pass of rolling, such as application of a tension and a reduction control, is completed, the third pass of rolling is started by the cold rolling mill 1. In the condition where the strip end portion in a several-turn amount is gripped by the winding/unwinding device 4, the third-pass rolling is finished.

20 **[0148]** After the preparation for a fourth pass of rolling, such as application of a tension and a reduction control, is completed, the fourth pass of rolling is started by the cold rolling mill 1. An output coil 103a having undergone the fourth-pass rolling is wound onto the winding/unwinding device 3, is extracted therefrom and is carried out.

25 **[0149]** Similarly, an input coil 101b is fed into the unwinding device 2, an output coil 103b is carried out from the winding/unwinding device, an input coil 101c is fed into the unwinding device 2, and an output coil 103c is carried out from the winding/unwinding device 3.

[0150] In this case, the leading end and tail end portions of the strips of the output coils 103a to 103c are unrolled portions, and the off-gage rate is as high as about 2.5%. In addition, threading the cold rolling mill 1 is conducted six times in total, and reversible rolling is performed twelve times in total. Thus, the actual rolling time in the operation time is short, so that production efficiency is poor. The second related art is to solve the problem involved in the first related art.

30 **[0151]** Fig. 9 is a schematic view of cold-rolled material equipment according to the second related art. The components equivalent to those in Fig. 1 are denoted by the same reference symbols as used above.

[0152] In Fig. 9, the cold-rolled material equipment according to the second related art includes, as main components: a reversible cold rolling mill 1; a unwinding device 2 for unwinding a strip of an input coil 101; a winding/unwinding device 3A (first winding/unwinding device) disposed on the entry side of a first pass of the cold rolling mill 1; a winding/unwinding device 4A (second winding/unwinding device) disposed on the delivery side of the first pass of the cold rolling mill 1; a joining device 5 for forming a buildup coil 102 from a plurality of input coils 101; a cutting device 6 for cutting the strip of the buildup coil 102 to form output coils 103; a buildup-coil winding/unwinding device 111 for forming the buildup coil; a winding device 112 which is disposed on the entry side of the first pass of the cold rolling mill 1 and winds the output coil 103; a winding device 113 disposed on the delivery side of the first pass of the cold rolling mill 1; and a controller 20 for controlling the cold rolling mill 1, the unwinding device 2, the winding/unwinding devices 3A, 4A, the joining device 5, the cutting device 6, the buildup-coil winding/unwinding device 111, and the winding devices 112, 113.

35 **[0153]** Incidentally, solid type reels are applied to the winding/unwinding devices 3A, 4A and the buildup-coil winding/unwinding device 111, whereas collapsible type reels are applied to the unwinding device 2 and the winding devices 112, 113.

40 **[0154]** Description will be made of an operation in the case where three input coils 101 are rolled in four passes by the cold-rolled material equipment according to the second related art. The input coil 101a is fed into and unwound from the unwinding device 2, and the leading end of the strip of the input coil 101a is gripped by, and the strip is wound onto, the buildup-coil winding/unwinding device 111. When the tail end of the strip of the input coil 101a reaches and is stopped at the joining position of the joining device 5, the input coil 101b is fed into the unwinding device 2. The strip of the input coil 101b is unwound until its leading end is fed out to the joining position of the joining device 5, whereon the strip is stopped, and the tail end of the strip of the first input coil 101a and the leading end of the strip of the second input coil 101b are joined by the joining device 5. The strip obtained upon the joining is wound onto the buildup-coil winding/unwinding device 111.

45 **[0155]** Similarly, the tail end of the strip of the second input coil 101b and the leading end of the strip of a third input coil 101c are joined by the joining device 5, and the strip obtained upon the joining is wound onto the buildup-coil winding/unwinding device 111. Consequently, a buildup coil 102 is formed at the buildup-coil winding/unwinding device 111.

50 **[0156]** The strip of the buildup coil 102 is unwound from the buildup-coil winding/unwinding device 111, is threaded the cold rolling mill 1, and is gripped by the winding/unwinding device 4A. After a reduction control, a first pass of rolling

is conducted by the cold rolling mill 1. Thereafter, the strip is subjected to second and third passes of reversible rolling between the winding/unwinding device 3A and the winding/unwinding device 4A.

5 [0157] After the third pass is finished, the grip by the winding/unwinding device 3 is released, and the strip end is unwound from the winding/unwinding device 3. The strip end thus unwound is gripped by the winding device 112, and, after a reduction control, a fourth pass of rolling is conducted. When the strip of a predetermined length corresponding to an output coil 103a is wound onto the winding device 112, the strip of the buildup coil 102 is cut at a strip cutting position by the cutting device 6a, and the output coil 103a thus cut off is extracted from the winding device 112 and carried out.

10 [0158] Similarly, the remaining strip is also cut by the cutting device 6a, and output coils 103b, 103c thus cut off are sequentially extracted from the winding device 112 and carried out. Incidentally, a collapsible type reel is applied to the winding/unwinding device 112, as above-mentioned.

[0159] Incidentally, the cutting device 6b is disposed between the cold rolling mill 1 and the winding device 113, and cuts the strip of the buildup coil 102 in a pass in which winding is completed at the winding device 113.

15 [0160] In this case, unrolled portions are generated only at the leading end of the strip of the output coil 103a and the tail end of the strip of the output coil 103c, so that off-gage rate can be remarkably lowered. In addition, since the threading the cold rolling mill 1 is conducted twice and reverse rolling is conducted four times, the actual rolling time in the operation time is prolonged, and production efficiency is enhanced, as compared with the first related art.

20 [0161] While the case where three input coils are rolled has been described above for convenience, the cold-rolled material equipment according to the second related art is presumed to be applied to a plant of a comparatively large scale with an annual output of not less than 800,000 tons. The cold-rolled material equipment according to the second related art has an increased initial cost due to the added components such as the joining device 5, the cutting device 6, the buildup-coil winding/unwinding device 111 and the winding devices 112, 113, as compared with the cold-rolled material equipment according to the first related art. Besides, since the multiplicity of input coils are built up into one coil and the resulting buildup coil is large in length and size, the winding/unwinding devices 3A, 4A and the buildup-coil winding/unwinding device 111 are necessarily large, so that the initial cost is increased.

25 [0162] In addition, when the buildup coil 102 is enlarged, it is difficult to apply collapsible type reels to the winding/unwinding devices 3A, 4A and the buildup-coil winding/unwinding device 111, so that solid block type reels must be applied. Therefore, the winding devices 112 and 113 to which collapsible type reels are applied are separately needed, in addition to the winding/unwinding devices 3A, 4A and the buildup-coil winding/unwinding device 111.

30 [0163] The cold-rolled material equipment according to the second related art is presumed to be applied to a plant of a comparatively large scale with an annual production of not less than 800,000 tons. In this case, some rise in initial cost does not matter, since priority is given to a lowering in off-gage rate and an enhancement of production efficiency. If the cold-rolled material equipment according to the second related art is applied to a small- to medium-scale plant with an annual production of about 300,000 to 600,000 tons, however, the problem of the initial cost becomes conspicuous, and there is a problem from the viewpoint of cost-effectiveness.

35 [0164] An effect of the present embodiment will be described by comparison with the first related art. In the cold-rolled material equipment according to the present embodiment, threading the cold rolling mill 1 is conducted twice, and reversible rolling is performed four times. Specifically, since the buildup coil 102 is formed in the first pass and reversible rolling of the buildup coil 102 is conducted in the second and following passes, the joint portion can also be rolled at a normal rolling speed, whereby production efficiency is enhanced as compared with the first related art. In addition, an unrolled portion is generated only at the leading end of the strip of the output coil 103a and the tail end of the strip of the output coil 103c, so that off-gage rate can be greatly lowered. Further, there is little portion which is rolled at a non-steady rolling speed, so that strip thickness accuracy is enhanced. Thus, a high efficiency and a high yield comparable to those in the second related art can be maintained.

40 [0165] Another effect of the present embodiment will be described by comparison with the second related art. In the first pass, following to the rolling of the first input coil 101a and the joining between the first input coil 101a and the second input coil 101b, rolling and joining are repeated, and, specifically, first-pass rolling by the cold rolling mill 1 and the joining between the tail end of a preceding coil and the leading end of a succeeding coil by the joining device 5 are carried out, to build up a plurality of input coils 101 into one buildup coil 102. This eliminates the need for a buildup-coil winding/unwinding device 111, which is indispensable in the second related art. By this, equipment configuration can be simplified, with the result that initial cost can be held low.

45 [0166] Further, as will be described later, the winding devices 112 and 113 indispensable in the second related art are unnecessitated, and the winding/unwinding devices 3 and 4 can be restrained from being enlarged. This ensures that equipment configuration can be simplified, and, consequently, initial cost can be further curtailed.

50 [0167] Thus, it is possible not only to maintain a high efficiency and a high yield but also to cut down the initial cost, thereby enhancing investment cost-effectiveness, in a small- to medium-scale plant with an annual production of about 300,000 to 600,000 tons.

[0168] Furthermore, in the present embodiment, a joining device of a mash seam welding system is used as the joining

device 5. This makes it possible to enhance investment cost-effectiveness.

<Configuration Concerning Joining and Effect Thereof>

5 **[0169]** In formation of the buildup coil 102, it is presumed that the first input coil 101a and the second input coil 101b which have a uniform thickness are joined, and the second input coil 101b and the third input coil 101c which have a uniform thickness are joined; in other words, it is presumed that the buildup coil 102 is free of variations in thickness. In practice, however, differences in strip thickness may be present among the input coils 101a to 101c due to errors, causing generation of a step at the joint portion. The joint portion is located in an inner layer portion of the buildup coil 102; if a tension is exerted on the coil in this condition, therefore, the step at the joint portion would be transferred to the inside and the outside of each layer, leading to a product defect which is dealt with as a crack.

10 **[0170]** For example, when it is assumed that the first input coil 101a has a strip thickness of 3.2 mm and the second input coil 101b has a strip thickness of 2.0 mm and the third input coil 101c has a strip thickness of 2.6 mm, a step of 1.2 mm will be formed at the joint portion between the first input coil 101a and the second input coil 101b.

15 **[0171]** In this instance, a process computer 21 (see Fig. 1) provided as a host computer for the controller 20 preliminarily manages the strip thickness of each of the input coils 101, and, for example, the order of feeding-in of the second input coil 101b and the third input coil 101c is changed. After the change in the order of feeding-in, the step at the joint portion between the first input coil 101a and the second input coil 101b is 0.6 mm, and the step at the joint portion between the second input coil 101b and the third input coil 101c is 0.6 mm.

20 **[0172]** Thus, the order of the coils fed into the unwinding device 2 is conditioned beforehand so that the absolute values of strip thickness differences will be not more than 1 mm, whereby it is possible to lower the possibility that a step at a joint portion located in an inner layer portion of the buildup coil might cause transfer of a crack to the adjacent coil layers. Furthermore, it is desirable that the absolute values of strip thickness differences will be not more than 0.5 mm.

25 **[0173]** In the present invention, a joining device of a mash seam welding system is used as the joining device 5, for the purpose of reducing initial cost.

[0174] Fig. 10 is a conceptual view of the mash seam welding system.

30 **[0175]** On the other hand, when the joining device of the mash seam welding system is used, a problem relating to the joint portion is newly generated. A mash seam welding machine adopts a system wherein materials to be joined are placed to overlap each other and clamped between electrode wheels, and an electric current is passed therethrough to cause contact resistance and internal resistance heating of the materials, whereby a molten-solidified portion called nugget N is formed and the materials are joined. This results in that the strip thickness of the joint portion after the finish of the joining has an increased value of 1.2 to 1.5 times the original. The joint portion increased in thickness constitutes a step, which applies an excessive force to the rolls when passing the rolling mill 1. Furthermore, the step may be transferred onto the work rolls as marks. In addition, the step at the joint portion may be transferred to the inside and the outside of each coil layer. There has been a problem of causing such a product defect.

35 **[0176]** In operation of the joining device 5, a cross swaging treatment of inclining swaging rollers and rolling the joint portion increased in thickness is carried out after the mash seam welding. This ensures that the step can be smoothed, and the problem concerning the joint portion can be solved. Now, the configuration and operation of the joining device 5 will be described.

40 **[0177]** Fig. 11 is a schematic view of the joining device 5. The joining device 5 includes a pair of upper and lower electrode wheels 51, 52, a pair of upper and lower pressure rollers 53, 54, entry-side and delivery-side clamp devices 55, 56, a carriage frame 57, an electrode wheel pressing device 58 and a pressure roller pressing device 59. The upper electrode wheel 51 and the upper pressure roller 53 are supported on an upper horizontal frame of the carriage frame 57 through the electrode wheel pressing device 58 and the pressure roller pressing device 59, respectively, whereas the lower electrode wheel 52 and the lower pressure roller 54 are supported on a lower horizontal frame of the carriage frame 57 through mount blocks, respectively. The pair of upper and lower pressure rollers 53, 54 are disposed adjacently to the pair of upper and lower electrode wheels 51, 52 in the carriage frame 57.

45 **[0178]** At the time of joining, first, both end portions of the strips are placed to overlap each other. In this condition, the strips are gripped by clamp members of the entry-side and delivery-side clamp devices 55, 56, to be fixed in position.

50 Next, the carriage frame 57 is moved in a welding direction by a driving device, whereby the pair of upper and lower electrode wheels 51, 52 and the pair of upper and lower pressure rollers 53, 54 supported on the carriage frame 57 are moved relative to the strips, and joining and pressing are carried out in a continuous manner. In this case, the overlapping portions of the strips are clamped between the pair of upper and lower electrode wheels 51, 52, the electrode wheels 51, 52 are pressed against the overlapping portions of the strips by the electrode wheel pressing device 58, and, while positively driving the electrode wheels 51, 52 to rotate by an electric motor, a welding current is passed to the electrode wheels 51, 52 to cause resistance heating, whereby welding (mash seam welding) is achieved. In addition, immediately after the welding of the overlapping portions by the electrode wheels 51, 52, the joint portion (welded joint) J is clamped between the pair of upper and lower pressure rollers 53, 54, the pressure rollers 53, 54 are pressed against the joint

portion by the pressure roller pressing device 59, and, while positively driving the pressure rollers 53, 54 to rotate by an electric motor, the joint portion of the strip is pressed and rolled.

[0179] The pressure roller pressing device 59 is provided with an inclining mechanism 60 for controlling the inclination angles of axes 61, 62 of the pressure rollers 53, 54. Incidentally, for avoiding complication of drawing, the electric motor and a chain and a sprocket mechanism for driving the pressure rollers to rotate are omitted in the drawing.

[0180] Fig. 12 is a schematic view of the inclining mechanism 60. By operating the inclining mechanism 60, the inclination angle of the axis of the pressure roller 53 can be set to an arbitrary angle in a horizontal plane. The inclining mechanism 60 includes a rotating shaft 71 rotatably inserted in the upper horizontal frame of the carriage frame 56, and an electric motor 74 for rotationally driving the rotating shaft 71 through pinions 72, 73, and the electric motor 74 is controlled by an inclination angle controller 75. In addition, the inclining mechanism 60 has an angle sensor 76 for detecting the inclination angle of the pressure roller 53. Before the start of joining, the inclination angle controller 75 is supplied with angle information according to the strip thickness of the strips from a host controller 77, sets an angle, and controls driving of the electric motor 74 by use of a signal from the angle sensor 76, in such a manner that the inclination angle of the pressure roller 53 will coincide with the set angle.

[0181] Details of an action wherein a plastic flow (metal flow) in a direction perpendicular to a weld line is accelerated by inclination of the axes 61, 62 of the pair of upper and lower pressure rollers 53, 54 will be described referring to Fig. 13.

[0182] Fig. 16 is a diagram showing a metal flow within an arc-of-contact length in the case of rolling a joint portion J by inclining the axes 61, 62 of the pressure rollers 53, 54, and it shows the case of the upper pressure roller 53, as an example. In the figure, letter A denotes an arrow indicating the moving direction (rolling direction) of the pressure roller 53, letter X denotes a straight line virtually indicating the weld line (joining line) of the joint portion J present on the moving direction A, and letter Y denotes a straight line orthogonal to the weld line X. In addition, numeral 63 denotes a straight line passing through a width-directionally central portion in a direction perpendicular to the axis of the pressure roller 53, and letter α denotes the inclination angle of the pressure roller 53 (the angle between the weld line X and the straight line 63 in the direction perpendicular to the axis of the upper pressure roller 53). Furthermore, numeral 64 denotes an arc-of-contact length portion where the pressure roller 53 makes contact with the joint portion J, letter R denotes a velocity vector of the pressure roller 53 in the arc-of-contact length portion 64, letter R1 denotes that component of the velocity vector R which is in the direction of the weld line X, and letter R2 denotes that component of the velocity vector R which is in a direction perpendicular to the weld line X.)

When the pressure roller 53 is positively driven to rotate while pressing the pressure roller 53 against the joint portion J in the condition where the axis 61 of the pressure roller 53 is inclined in a horizontal plane relative to the straight line Y orthogonal to the weld line X, a frictional force corresponding to the velocity vector component R2 in the direction perpendicular to the weld line X acts on the arc-of-contact length portion 64 in contact with the joint portion J, due to a pressing force and the coefficient of friction between the pressure roller 53 and the joint portion J. In addition, a shearing force 82 (see Figs. 14A to 15B) in a direction orthogonal to the weld line X that corresponds to the frictional force acts on the joint portion J. As a result, not only a metal flow in the direction of the velocity vector component R1 (the direction parallel to the weld line X) but also a metal flow in the direction of the velocity vector component R2 (the direction perpendicular to the weld line X), that is a plastic flow in the direction perpendicular to the weld line X due to shearing deformation caused by the shearing force 82, is generated in the joint portion J. By this shearing deformation or plastic flow in the direction perpendicular to the weld line X, the step S at the joint portion J can be smoothened.

[0183] The angle α by which the pair of upper and lower pressure rollers 53, 54 are inclined can be set in two kinds of orientations. A first setting method corresponds to a case where, as shown in Figs. 14A and 14B, the axes 61, 62 of the pair of pressure rollers 53, 54 are each inclined relative to the straight line Y orthogonal to the weld line X in such a manner that moving direction portions 53A, 54A of the pair of pressure rollers 53, 54 are oriented in the opposite directions to the directions where the strip portions contacted first by the pressure rollers 53, 54 are present, in a horizontal plane. In other words, the axes 61, 62 of the pressure rollers 53, 54 are inclined in such a manner that the axial ends of the pressure rollers 53, 54 located at those portions of the joint portion J of the strip which are on the thicker side of the step S at the joint portion J (those material portions of the joint portion J which are contacted first by the pressure rollers 53, 54) are oriented in the rolling direction A of the joint portion J. In this case, the shearing forces 82 corresponding to the velocity vector component R2 act in the directions from the step S of the joint portion J of the strip toward the strip portions contacted first by the pressure rollers 53, 54, so that the step portion is rolled and smoothened while a shearing deformation is imparted thereto in the same direction perpendicular to the weld line. Incidentally, in this case, forces in the opposite directions to the shearing forces 82 act on the pressure rollers 53, 54 from the joint portion J as thrust forces 81. In other words, the shearing forces 82 as reactional forces of the thrust forces 81 act on the joint portion J.

[0184] A second setting method corresponds to a case where, as shown in Figs. 15A and 15B, the pressure rollers 53, 54 are inclined in the reverse directions to those in the first setting method. Specifically, the axes 61, 62 of the pair of pressure rollers 53, 54 are each inclined relative to the straight line Y orthogonal to the weld line X in such a manner that the moving direction portions 53A, 54A of the pair of pressure rollers 53, 54 are oriented in the directions where the strip portions contacted first by the pressure rollers 53, 54 are present, in a horizontal plane. In other words, the axes

61, 62 of the pressure rollers 53, 54 are inclined in such a manner that the axial ends of the pressure rollers 53, 54 located at those portions of the joint portion J (mash seam-welded joint) of the strip which are on the thinner side of the step S at the joint portion J (those material portions of the joint portion J which are not contacted first by the pressure rollers 53, 54) are oriented in the rolling direction A of the joint portion J. In this case, the shearing forces 82 corresponding to the velocity vector component R2 act in the directions from the step S of the joint portion J of the strip toward the strip portions relevant to the metallic material contacted first by the pressure rollers 53, 54, so that the step portion is rolled and smoothed while a shearing deformation is imparted thereto in the same direction perpendicular to the weld line. In this instance, also, forces in the opposite directions to the shearing forces 82 act on the pressure rollers 53, 54 from the joint portion J as thrust forces 81.

[0185] In the present embodiment, the first setting method is adopted. The reason is as follows. Even when the pair of upper and lower pressure rollers 53, 54 are inclined by the second setting method, the step S can be smoothed because it undergoes a plastic flow caused by the shearing force 82. In this case, however, the portion of the step S is folded into the base material as shown in Fig. 15B, so that a problem of embedding of the step S into the base material in a crack-like form is newly generated. This does not matter in the case where the joint portion J is required simply to have a smooth surface and it is applied to a part which does not need strength. In the case of application to a part on which a stress acts and in a plastic-working use such as the case where the strip is press molded like a tailored blank, however, the leading end portion of the embedded step constitutes a specific stress field, possibly causing breakage. Therefore, the directions in which the pressure rollers 53, 54 are to be inclined are preferably as shown in Figs. 14A and 14B, wherein the axes 61, 62 of the pair of pressure rollers 53, 54 are each inclined relative to the straight line Y orthogonal to the weld line X in such a manner that the moving direction portions 53A, 54A of the pair of pressure rollers 53, 54 are oriented in the opposite directions to the directions where the strip portions contacted first by the pressure rollers 53, 54 are present, in a horizontal plane. In this case, as shown in Fig. 14B, the step at the joint portion can be smoothed while avoiding embedding of the step S into the base material in a crack-like form, so that the quality of the joint portion is enhanced.

<Other Configurations and Effects Thereof>

[0186] In the present embodiment, the outside diameter of the buildup coil 102 is not more than $\phi 3000$. In addition, the tension on the strip when the outside diameter of the buildup coil 102 is larger is set to be gradually lowered, as compared with that when the outside diameter is smaller. Fig. 16 is a diagram showing a tension control at the time of winding the buildup coil 102. When the outside diameter of the buildup coil 102 is less than $\phi 1500$, a steady, predetermined tension is imparted to the strip. When the outside diameter of the buildup coil 102 is not less than $\phi 1500$, however, the tension is set to be gradually lowered as the outside diameter increases.

[0187] This makes it possible to limit the coil tightening force acting on the buildup coil 102, and to restrain the winding/unwinding devices 3, 4 from being enlarged due to the enlargement of the outside diameter of the buildup coil 102.

[0188] As a result, the winding/unwinding devices 3, 4 in the present invention permits application of collapsible type reels thereto, while the winding/unwinding devices 3A, 4A in the second related art necessitate application of solid block type reels thereto.

[0189] In the present embodiment, the cutting devices 6a, 6b each have an swing mechanism (not shown).

[0190] A cutting device in tandem cold rolling equipment with an annual production of not less than 1,000,000 tons is generally of a flying shear type for cutting the coil while rolling is continued, and the strips after cutting-up are alternately wound by use of two winding devices. For restraint of worsening of off-gage rate and a reduction in annual production, the strip velocity at the time of coil cutting is lowered only to a value of about 100 to 300 mpm. In addition, the conventional cutting device of the flying shear type for cutting the coil while rolling is continued cannot be said inexpensive. Therefore, when the conventional cutting device is adopted in a small- to medium-scale plant with an annual production of about 300,000 to 600,000 tons, there arises a problem of an increased initial cost.

[0191] In the present embodiment, the rolling speed at the time of cutting the buildup coil 102 is set at a low speed (for example, 10 mpm), as has been described in connection with the operation in the fourth pass (final pass). Therefore, a comparatively inexpensive cutting device having an swing mechanism can be applied, instead of the conventional expensive cutting device of the flying shear type, so that initial cost can be curtailed.

[0192] The cutting device 6a having an swing mechanism is capable of cutting a strip without stopping rolling, as has been described in connection with the operation in the fourth pass.

[0193] In the present invention, the rolling speed at the time of cutting up the buildup coil 102 by the cutting device 6a is set at a low speed (for example, 10 mpm), as has been described in connection with the operation in the fourth pass (final pass). While the strip of the buildup coil 102 is being rolled at a low speed by the cold rolling mill 1, the output coil 103 is cut off by the cutting device 6a, is wound onto the winding/unwinding device 3 at a high speed, and is thereafter extracted and carried out. This series of operations are carried out, for example, in about 30 seconds. On the other hand, when the distance from the cutting position of the cutting device 6a to the winding/unwinding device 3 is assumed to be

5 m and the leading end of the strip of the buildup coil 102 after cutting is assumed to be fed out from the cutting position of the cutting device 6a to the winding/unwinding device 3 according to the rolling speed (10 mpm) of the cold rolling mill 1, it takes 30 seconds for the leading end to arrive at the winding/unwinding device 3. In other words, the first output coil 103a is carried out before the preparation for winding of the second input coil 103b.

5 **[0194]** Thus, in addition to the application of a collapsible type reel to the winding/unwinding device 3, there is a merit that the operation of extracting and carrying out an output coil 103 after cutting of the buildup coil 102 and thereafter winding the next output coil 103 in a continuous manner can be conducted by use of the single winding/unwinding device 3, so that the winding/unwinding device 3A with the solid block type reel and the winding device 112 which are indispensable in the second related art are unnecessary. Incidentally, in the case of the present embodiment, naturally,
10 the winding/unwinding device 4A and the winding device 113 are unnecessary.

[0195] This enables simplification of equipment configuration and, consequently, a reduction in initial cost.

[0196] Besides, in the second related art, rolling is stopped at the time of cutting. Therefore, generation of a stop mark due to a change in the coefficient of friction between the work roll and the strip occurs on the surface of the strip clamped between the work rolls. In addition, the stop marks would be transferred also to the work rolls, so that the stop marks
15 may be transferred onto the strip surfaces at regular intervals corresponding to the rotational pitch of the work rolls, during the subsequent rolling. These stop marks, if generated in the final pass, would spoil the quality as to surface gloss, rendering the product defective in the case where the quality requirement for the cold-rolled material is rigorous.

[0197] In the present embodiment, rolling is continued (low-speed rolling) even at the time of cutting, whereby stop marks of the work rolls can be prevented from being formed on the strip.

20 **[0198]** Meanwhile, although the problem relating to the joint portion is solved as above-mentioned, the product coil may be required to have further accuracy.

[0199] In the present embodiment, the coil cutting in the final pass is conducted immediately after the passage of the joint portion through the cutting device. In other words, the cutting position is located immediately behind the joint portion. The cutting position is computed by the controller 20, from the coil outside diameters and the reel rotational speeds of
25 the winding/unwinding devices 3, 4.

[0200] This ensures that the joint portion can be disposed at the outer surface of the output coil 103, so that the treatment of the joint portion can be easily carried out after the output coil 103 is extracted.

[0201] Furthermore, the coil cutting in the final pass may be conducted immediately before the passage of the joint portion through the cutting device and immediately after the passage of the joint portion through the cutting device. In
30 other words, the joint portion is cut off from the output coil 103 by the cutting device 6a.

[0202] This ensures that the joint portion is not wound around the output coil 103, so that an after-treatment of the joint portion can be unnecessary.

[0203] In addition, before the final-pass rolling in the rolling step is started, the work rolls may be replaced with dulled work rolls in the condition where the strip is threaded the cold rolling mill, followed by the final-pass rolling.

35 **[0204]** This makes it possible to enhance malleability at the time of deep drawing conducted in a preparatory step for the cold rolling step, or to enhance adhesion and/or sharpness of painting.

Second Embodiment

40 **[0205]** Now, a second embodiment of the present invention will be described referring to the drawing. Fig. 17 is schematic view of a cold-rolled material equipment according to the second embodiment of the present invention. While the cold rolling mill 1 in the first embodiment has been of a one-stand type, cold rolling mills 1a, 1b in the second embodiment constitute a two-stand type mill.

[0206] While the cold rolling mill 1 in the first embodiment has been described to be of the one-stand type for convenience
45 of description, a two-stand type is preferred in order that the effects to enhance the annual production and to reduce the off-gage rate are exhibited to the utmost. Further, the two-stand type is preferable also from the viewpoint of investment cost-effectiveness. The second embodiment is the same as the first embodiment in other points of configuration, in control, in operation, and in the effects obtained.

50 Third Embodiment

[0207] Now, a third embodiment of the present invention will be described referring to the drawings.

<Main Configuration>

55 **[0208]** Fig. 18 is a schematic view of cold-rolled material equipment according to the third embodiment of the present invention. The cold-rolled material equipment according to the present embodiment has a strip storage device 9 disposed between the joining device 5 and the cold rolling mill 1, in addition to the configuration of the cold-rolled material equipment

according to the first embodiment.

[0209] The strip storage device 9 has a movable roller 92 provided between two stationary rollers 91a, 91b. The strip storage device 9 stores a strip by lowering the movable roller 92 by means of a driving device (not shown), and release the stored strip by raising the movable roller 92. The operation of the strip storage device 9 is controlled by the controller 20.

<Main Control>

[0210] Fig. 19 is a control flow showing a procedure executed by the controller 20. Controls in the second to fourth passes are the same as those in the first embodiment; therefore, only a control in the first pass will be shown.

[0211] In the control flow of the first embodiment shown in Fig. 2, the controller 20 controls the cold rolling mill 1 so that the cold rolling mill 1 is stopped according to the procedure concerning the feeding-in of the input coil 101 and the joining (S1104, S1107). In the control flow of the present embodiment, on the other hand, the controller 20 controls the cold rolling mill 1 so as to perform rolling at a low speed (for example, 10 mpm) according to the procedure related to the feeding-in of the input coil 101 and the joining (S1104B, S1107B).

[0212] In the control flow of the first embodiment shown in Fig. 2, the controller 20 controls the winding/unwinding device 4 so that the winding/unwinding device 4 is stopped according to the stopping of the cold rolling mill 1 (S1403, S1406). In the control flow of the present embodiment, in contrast, the controller 20 controls the winding/unwinding device 4 so as to winding the strip at the low speed according to the low-speed rolling of the cold rolling mill 1 (S1403B, S1406B).

[0213] The controller 20 controls the strip storage device 9 in the following manner. When the first coil 101a is fed into and mounted onto the unwinding device 2 and the strip is unwound, the movable roller 92 is lowered, and the strip storage device 9 thereby starts storing the strip. When a predetermined length of the strip is stored, the lowering of the movable roller 92 is stopped (S1901B). According to the procedure in which the second input coil 101b is fed into the unwinding device 2 and the tail end of the strip of the first input coil 101a and the leading end of the strip of the second input coil 101b are joined, the movable roller 92 is raised, and the strip storage device 9 thereby gradually releases the stored strip. When the first input coil 101a and the second input coil 101b are joined, the raising of the movable roller 92 is stopped (S1901B). Thereafter, the movable roller 92 is again lowered, and the strip storage device 9 thereby starts storing the strip. When a predetermined length of the strip is stored, the lowering of the movable roller 92 is stopped (S1903B). According to the procedure in which the third input coil 101c is fed into the unwinding device 2 and the tail end of the strip of the second input coil 101b and the leading end of the strip of the third input coil 101c are joined, the movable roller 92 is raised, and the strip storage device 9 thereby gradually release the stored strip. When the second input coil 101b and the third input coil 101c are joined, the raising of the movable roller 92 is stopped (S1904B).

[0214] Controls concerning the unwinding device 2 and the joining device 5 are substantially the same as those in the first embodiment.

<Main Operation>

[0215] In the first embodiment, in the first pass, the cold rolling mill 1 is kept stopped (S1104) during a series of operations in which the second input coil 101b is fed into the unwinding device 2 and the tail end of the strip of the first input coil 101a and the leading end of the strip of the second input coil 101b are joined (S1204 → S1205 → S1206 → S1501). On the other hand, the cold-rolled material equipment according to the present embodiment operates as follows.

[0216] When the first input coil 101a is fed into the unwinding device 2 and the strip thereof is unwound, the strip storage device 9 stores the strip (S1201 → S1202 → S1901B). Thereafter, the strip of the first input coil 101a is rolled at a steady rolling speed and unwound (S1203 → S1103 → S1402). When the tail end of the strip reaches and is stopped at the joining position of the joining device 5, strip is released from the strip storage device 9, and, simultaneously, the unrolled strip of the first input coil 101a is rolled at a low speed (for example, 10 mpm) by the cold rolling mill 1, and the rolled strip is wound onto the winding/unwinding device 4 according to the rolling speed of the cold rolling mill 1 (S1902B → S1104B → S1403B).

[0217] On the other hand, during the low-speed rolling, the second input coil 101b is fed into and mounted onto the unwinding device 2, the strip thereof is unwound, and the tail end of the strip of the first input coil 101a and the leading end of the strip of the second input coil 101b are joined (S1204 → S1205 → S1206 → S1501).

[0218] If the series of operations concerning the feeding-in of the second input coil 101b and the joining between the first input coil 101a and the second input coil 101b are conducted in about two minutes, for example, the length of the strip undergoing low-speed rolling (10 mpm) during the series of operations is 20 m. Accordingly, the strip storage device 9 must store the strip by a length of 20 m.

[0219] When the first input coil 101a and the second input coil 101b are joined together, rolling by the cold rolling mill 1 at the steady rolling speed is again conducted to roll the unrolled strip of the first input coil 101a. Subsequently, the strip of the second input coil 101b having been joined is rolled at the steady rolling speed by the cold rolling mill 1, and

the strip is unwound from the unwinding device 2 and wound onto the winding/unwinding device 4 according to the rolling speed of the cold rolling mill 1, during when a new strip is stored into the strip storage device 9 (S1105 → 1404 → S1207 → S1106 → S1405 → S1903B).

5 [0220] When the strip of the second input coil 101b is unwound and the tail end of the strip reaches and is stopped at the joining position of the joining device 5, the strip is released from the strip storage device 9; simultaneously, the unrolled strip of the second input coil 101b is rolled at a low speed by the cold rolling mill 1, to be wound onto the winding/unwinding device 4 according to the rolling speed of the cold rolling mill 1 (S1904B → S1107B → S1406B).

10 [0221] On the other hand, during the low-speed rolling, the third input coil 101c is fed into and mounted onto the unwinding device 2, the strip thereof is unwound, and the tail end of the strip of the second input coil 101b and the leading end of the strip of the third input coil 101c are joined (S1208 → S1209 → S1210 → S1502).

15 [0222] When the second input coil 101c and the third input coil 101c are joined together, rolling by the cold rolling mill 1 at the steady rolling speed is again conducted to roll the unrolled strip of the second input coil 101b. Subsequently, the strip of the third input coil 101c having been joined is rolled at the steady rolling speed by the cold rolling mill 1, and the strip is unwound from the unwinding device 2 and wound onto the winding/unwinding device 4 according to the rolling speed of the cold rolling mill 1 (S1108 → 1407 → S1211 → S1109 → S1408).

[0223] When the strip of the third input coil 101c is unwound, the unwinding device 2 is stopped, and, when the tail end of the strip of the third input coil 101c reaches a position immediately upstream of the cold rolling mill 1, the cold rolling mill 1 is stopped, to finish the first pass. The winding/unwinding device 4 is stopped according to the stopping of the cold rolling mill 1 (S1212 → S1110 → S1111 → S1409).

20 [0224] As a result, the buildup coil 102 is formed at the winding/unwinding device 4 (S1410).

[0225] The operations of the cold-rolled material equipment according to the present embodiment in the second to fourth passes are the same as in the first embodiment, as described below.

<Main Effect>

25 [0226] The effect of the present embodiment will be described by comparison with the first embodiment.

[0227] In the first embodiment, in the first pass, the cold rolling mill 1 is kept stopped (S1104) during a series of operations in which the second input coil 101b is fed into the unwinding device 2 and the tail end of the strip of the first input coil 101a and the leading end of the strip of the second input coil 101b are joined (S1204 → S1205 → S1206 → 30 S1501). In addition, the cold rolling mill 1 is kept stopped (S1108) during a series of operations in which the third input coil 101c is fed in and the tail end of the strip of the second input coil 101b and the leading end of the strip of the second input coil 101c are joined (S1208 → S1209 , S1210 , S1502).

35 [0228] When the stop of rolling, that is, rolling speed becomes 0 mpm, the coefficient of friction between the work roll and the strip is changed, with the result of formation of stop marks, at the surfaces of the strip clamped between the work rolls. Further, the stop marks would be transferred to the work rolls. During the subsequent rolling, therefore, the stop marks may be transferred to the strip surfaces at regular intervals corresponding to the rotational pitch of the work rolls. Where the stop marks are generated in the first pass, they may be made so inconspicuous that they are visually imperceptible, by continuation of the rolling a plurality of times. Where a high quality in regard of surface gloss is required rigorously, however, a problem that the strips with the stop marks are dealt with as defective products is newly generated.

40 [0229] In the present embodiment, the strip storage device 9 is provided, and the strip is stored into the strip storage device 9 at other times than the time of joining. At the time of joining, the strip stored in the strip storage device 9 is released, and rolling is thereby continued by low-speed rolling even in the condition where the tail end of the preceding coil is stopped. This makes it possible to prevent stop marks of the work rolls from being formed on the strip during the joining operation.

45 [0230] Furthermore, where the time required for the joining operation is two minutes, for example, the length of the strip stored can be set to 20 m by setting the rolling speed in low-speed rolling to 10 mpm. As the rolling speed in the low-speed rolling is lowered, the length of the strip stored in the strip storage device can be shortened, and the strip storage device can be made compact accordingly. As a result, equipment configuration can be simplified. Incidentally, the rolling speed can be lowered to the limiting resolution speed (approaching zero) of the cold rolling mill 1.

50 <Configurations Concerning Strip Thickness Control and Shape Control, and Effects Thereof>

55 [0231] In the present embodiment, low-speed rolling is conducted during the joining operation and at the time of cutting. This, however, would produce a new problem of a lowering in strip thickness control accuracy or a lowering in shape control accuracy. Specifically, while feedback control is applied to the strip thickness control and shape control during rolling at a steady rolling speed, such a control leads to a conspicuous time lag and, hence, to a lowered accuracy when applied to rolling at a low speed.

[0232] The cold rolling mill 1 is, for example, a six-high UC mill including top and bottom work rolls 11, 11 which make

direct contact with the work (material to be rolled) and roll the work, top and bottom intermediate rolls 12, 12 which support the work rolls in the vertical direction, and top and bottom back-up rolls 13, 13 which support the intermediate rolls 12, 12 in the vertical direction. A hydraulic rolling reduction device 14 is provided beneath the bottom back-up roll 13. Based on a command from the controller 20, the hydraulic rolling reduction device 14 moves a bearing for the bottom back-up roll 13 up or down, whereby the strip is rolled in such a manner as to obtain a predetermined rolling reduction. A load meter 15 is provided on the upper side of the top back-up roll 13, and information detected by the load meter 15 is outputted to the controller 20.

[0233] A strip thickness meter 16a, a strip velocity meter 17a, a shape meter 18a are provided on the entry side of the first pass of the cold rolling mill 1. A strip thickness meter 16b, a strip velocity meter 17b and a shape meter 18b are provided on the delivery side of the first pass of the cold rolling mill 1. Pieces of information detected respectively by these meters are outputted to the controller 20. The strip thickness meters 16 may be laser Doppler type velocimeters; or, alternatively, the strip velocity may be detected from the rotational speed of a deflector roller or the shape detector.

[0234] Strip thickness control during steady rolling will be described. During the steady rolling, BISRA-AGC control and monitor AGC control are jointly used, when required.

[0235] The BISRA-AGC control is a control process in which a variation in the strip thickness on the entry side of the cold rolling mill 1 is detected as a variation in rolling load by the load meter 15, and the rolling reduction of the rolls is controlled correspondingly to the load variation detected.

[0236] The monitor AGC control is a control process in which a variation in the strip thickness on the delivery side of the cold rolling mill 1 is detected by the strip thickness meter 16b on the delivery side, and the rolling reduction is controlled by proportional-plus-integral control while feeding back the thickness variation detected.

[0237] The strip thickness meter 16b is provided at a distance of several meters from the cold rolling mill 1, so that a time lag is generated in the value detected by the strip thickness meter 16b. During the steady rolling (for example, at 1000 mpm), the time lag produces little influence on control. When this system is applied during low-speed rolling (for example, at 10 mpm), however, the influence of the time lag makes it impossible to obtain appropriate information, and lowers the accuracy of strip thickness control.

[0238] Strip thickness control during low-speed rolling will be described. In the present embodiment, MF-AGC control is applied to low-speed rolling.

[0239] The MF-AGC control is a control as follows. The values detected by the strip thickness meter 16a on the entry side are put to tracking up to a position directly under the rolling stand deemed as the object of control. By use of the strip velocity meters 17a, 17b on the entry side and the delivery side, the respective strip velocities on both sides are detected. The controller 20 estimates the delivery-side strip thickness by multiplying the entry-side strip thickness by an entry-side-to-delivery-side strip velocity ratio, and controls the rolling reduction so that the deviation between the estimated value and a target value of strip thickness is reduced to zero.

[0240] Since the value detected by the strip thickness meter 16b is not used, a strip thickness control accuracy comparable to that during steady rolling can be maintained even during the time of low-speed rolling.

[0241] Shape control during steady rolling will be described. During the steady rolling, a feedback control is applied in which the shape of the strip is measured by the shape meter 18b on the delivery side, and correction is conducted based on deviations between command values of shape and actual values of shape.

[0242] The shape meter 18b is provided at a distance of several meters to ten and several meters from the cold rolling mill 1, so that a time lag is generated in the values detected at the shape meter 18b. The time lag produces little influence during steady rolling (for example, at 1000 mpm). When this system is applied during low-speed rolling (for example, at 10 mpm), however, the influence of the time lag makes it impossible to obtain appropriate information, and lowers the accuracy of shape control.

[0243] Strip thickness control during low-speed rolling will be described. In the present embodiment, a roll bender control or a coolant control or a combination of both controls is used.

[0244] The roll bender control is a control as follows. Fluctuations in the rolling load in the cold rolling mill 1 are detected by the load meter 15. The controller 20 computes a roll deflection attendant on the fluctuations, and, based on the result of computation, exerts a force on an end portion of the work roll 11 or the intermediate roll 12 so as to forcibly bend the roll, thereby controlling the roll deflection.

[0245] The coolant control is a control as follows. Several blocks obtained by cutting the roll surface of the work roll 11 or the intermediate roll 12 are preliminarily set. Fluctuations in the rolling load in the cold rolling mill 1 are detected by the load meter 15. The controller 20 computes a roll deflection attendant on the fluctuations, and, based on the result of computation, varies the quantity of coolant jetted on a block basis, thereby controlling the amount of expansion of the roll due to the working heating attendant on the rolling.

[0246] In neither of the controls, the information obtained at the shape meter 18b is used. Therefore, a strip thickness control accuracy comparable to the shape control accuracy during steady rolling can be maintained even during low-speed rolling.

[0247] Incidentally, the configurations concerning the strip thickness control and the shape control are provided also

in the first embodiment, and the same or similar control is applied also during the low-speed rolling at the time of cutting the buildup coil 102 in the final pass in the first embodiment.

Fourth Embodiment

5 **[0248]** Now, a fourth embodiment of the present invention will be described below referring to the drawing. Fig. 20 is a schematic view of cold-rolled material equipment according to the second embodiment of the present invention. While the cold rolling mill 1 in the third embodiment has been of a one-stand type, the cold rolling mills 1a, 1b in the second embodiment constitute a two-stand type mill.

10 **[0249]** While the cold rolling mill 1 in the third embodiment has been described to be of the one-stand type for convenience of description, a two-stand type is preferred in order that the effects to enhance the annual production and to reduce the off-gage rate are exhibited to the utmost. Further, the two-stand type is preferable also from the viewpoint of investment cost-effectiveness. The fourth embodiment is the same as the third embodiment in other points of configuration, in control, in operation, and in the effects obtained.

15 **[0250]** Furthermore, with the cold rolling mills 1a, 1b made to constitute a two-stand type mill, productivity can be further enhanced.

Description of Reference Numerals

20 **[0251]**

1, 1a, 1b	Cold rolling mill
2	Unwinding device
3	Winding/unwinding device (first winding/unwinding device)
25 3A	Winding/unwinding device (first winding/unwinding device, solid type)
4	Winding/unwinding device (second winding/unwinding device)
4A	Winding/unwinding device (second winding/unwinding Device, solid type)
5	Joining device
6, 6a, 6b	Cutting device
30 9	Strip storage device
11	Work roll
12	Intermediate roll
13	Back-up roll
14	Hydraulic rolling reduction device
35 15	Load meter
16a, 16b	Strip thickness meter
17a, 17b	Strip velocity meter
18a, 18b	Shape meter
20	Controller
40 21	Process computer
51, 52	Electrode wheel
53, 54	Pressure roller
55, 56	Clamp device
57	Carriage frame
45 58	Electrode wheel pressing device
59	Pressure roller pressing device
60	Inclining mechanism
61, 62	Axis
63	Straight line passing through width-directionally central portion in a direction perpendicular to axis
50 of pressure roller	
64	Arc-of-contact length portion
71	Rotating shaft
72, 73	Pinion
74	Electric motor
55 75	Inclination angle controller
76	Angle sensor
77	Host controller
81	Thrust force

82	Shearing force
91	Stationary roller
92	Movable roller
101, 101a to 101c	Input coil
5 102	Buildup coil
103, 103a to 103c	Output coil
111	Buildup-coil winding/unwinding device
112, 113	Winding device

10

Claims

1. A reversible cold rolling method for performing a plurality of passes of cold rolling while changing rolling direction by use of a unwinding device (2) by which a coil is unwound, at least one reversible cold rolling mill (1, 1a, 1b), first and second winding/unwinding devices (3, 4) provided respectively on an entry side and an delivery side of a first pass of the cold rolling mill (1, 1a, 1b), and a joining device (5) disposed between the unwinding device (2) and the first winding/unwinding device (3), the method comprising:
 - a rolling step (S1103) of guiding a strip of a first coil (101a) unwound from the unwinding device (2) directly to the cold rolling mill (1, 1a, 1b), rolling the strip and winding the rolled strip onto the second winding/unwinding device (4);
 - a joining step (S1501) of joining a tail end of the first coil (101a) and a leading end of a second coil (101b) subsequently unwound from the unwinding device (2), upon arrival of the tail end of the first coil (101a) at the joining device (5);
 - a first-pass coil building-up and rolling step (S1101 to S1111, S1201 to S1212, S1401 to S1410, S1501 to S1502, S1901B to S1904B) of repeating the rolling step (S1105, S1106, S1108, S1109) and the joining step (S1502) to perform the first-pass rolling by the cold rolling mill and the joining of the tail end of a preceding coil and the leading end of a succeeding coil by the joining device, from a subsequent second coil (101b) on, thereby building up a plurality of coils into one coil;
 - a reversible rolling step (S2101 to S4301, S4306, S4311, S4401 to S4406) of performing reversible rolling of the built-up coil (102) a predetermined number of times until a desired product strip thickness is reached; and
 - a cutting and winding step (S4302 to S4304, S4307 to S4309, S4312 to S4314, S4601 to S4603) of cutting the built-up coil (102) in a final pass of the reversible rolling step by a cutting device (7a, 7b) and winding the cut coils onto either of the first and second winding/unwinding devices (3, 4) to form a plurality of coils (103a to 103c).
2. The reversible cold rolling method according to claim 1, wherein a strip storage device (9) is provided between the cold rolling mill (1, 1a, 1b) and the joining device (5), and the rolling speed during joining of the tail end of the preceding coil and the leading end of the succeeding coil in the joining step (S1501, S1502, S1901B to S1904B) is set to be more than 0 mpm and not more than 50 mpm.
3. The reversible cold rolling method according to any one of claims 1 and 2, wherein the rolling speed at the time of cutting the coil (102) in the final pass in the cutting and winding step (S4302 to S4304, S4307 to S4309, S4312 to S4314, S4601 to S4603) is set to be more than 0 mpm and not more than 50 mpm.
4. The reversible cold rolling method according to any one of claims 1 to 3, wherein in the joining step (S1501, S1502, S1901B to S1904B) and the cutting and winding step (S4302 to S4304, S4307 to S4309, S4312 to S4314, S4601 to S4603), entry-side rolling speed and entry-side strip thickness and delivery-side rolling speed at the cold rolling mill (1, 1a, 1b) are measured, the strip thickness beneath work rolls of the cold rolling mill (1, 1a, 1b) is computed based on the measured values, and a strip thickness control such as to obtain a desired strip thickness is performed by a hydraulic rolling reduction device (14) possessed by the cold rolling mill (1, 1a, 1b).
5. The reversible cold rolling method according to any one of claims 1 to 4, wherein in the joining step (S1501, S1502, S1901B to S1904B) and the cutting and winding step (S4302 to S4304, S4307 to S4309, S4312 to S4314, S4601 to S4603), strip shape is controlled by a roll bender control or a coolant control or a combination of both controls on the basis of the computation result of roll deflection due to fluctuations in rolling load at the cold rolling mill (1, 1a, 1b).

6. The reversible cold rolling method according to any one of claims 1 to 5, wherein the order of feeding-in of coils to the unwinding device (2) is preliminarily controlled so that the absolute value of a strip thickness difference between a preceding coil and a succeeding coil will be not more than 1 mm, prior to the rolling step (S1101).
- 5
7. The reversible cold rolling method according to any one of claims 1 to 6, wherein joining is performed by use of a joining device of a mash seam welding system as the joining device (5), in the joining step (S1501, S1502).
- 10
8. The reversible cold rolling method according to claim 7, wherein a cross swaging treatment is performed immediately after the joining by the joining device (5) of the mash seam welding system.
- 15
9. The reversible cold rolling method according to any one of claims 1 to 8, wherein the outside diameter of the coil built up in the coil building-up and rolling step (S1101 to S1502, S1901B to S1904B) is set to be not more than $\phi 3000$.
- 20
10. The reversible cold rolling method according to any one of claims 1 to 9, wherein a tension on a strip when a coil outside diameter is larger is gradually decreased as compared with a tension on the strip when the coil outside diameter is smaller.
- 25
11. The reversible cold rolling method according to any one of claims 1 to 10, wherein in the reversible rolling step (S2101 to S4109) and the coil building-up and rolling step (1101 to 1111), rolling is performed by use of a two-stand cold rolling mill (1a, 1b) as the cold rolling mill.
- 30
12. The reversible cold rolling method according to any one of claims 1 to 11, wherein in the cutting and winding step (S4601 to S4603), coil cutting in the final pass is performed immediately after passage of a joint portion through the cutting device (7a, 7b).
- 35
13. The reversible cold rolling method according to claim 12, wherein in the cutting and winding step (S4601 to S4603), coil cutting in the final pass is performed immediately before passage of a joint portion through the cutting device (7a, 7b) and immediately after the passage of the joint portion through the cutting device (7a, 7b).
- 40
14. The reversible cold rolling method according to any one of claims 1 to 13, wherein work rolls are replaced by dulled work rolls in a condition where a strip is passed through the cold rolling mill, before start of final-pass rolling in the cutting and winding step (S4601 to S4603), and the final-pass rolling is performed.
- 45
15. Reversible cold rolling equipment for performing a plurality of passes of cold rolling while changing a rolling direction, by use of a unwinding device (2) by which a coil is unwound, at least one reversible cold rolling mill (1, 1a, 1b), first and second winding/unwinding devices (3, 4) provided respectively on an entry side and an delivery-side of a first pass of the cold rolling mill, and a joining device (5) disposed between the unwinding device (2) and the first winding/unwinding device (3), the equipment comprising
a controller (20) by which the unwinding device (2), the cold rolling mill (1, 1a, 1b), the first and second winding/unwinding devices (3, 4), the joining device (5) and cutting device (7a, 7b) are controlled so that:
- 50
- a strip of a first coil (101a) unwound from the unwinding device (2) is guided directly to the cold rolling mill (1, 1a, 1b), is rolled and is wound onto the second winding/unwinding device (4);
- a tail end of the first coil (101a) and a leading end of a second coil (101b) subsequently unwound from the unwinding device (2) are joined upon arrival of the tail end of the first coil (101a) at the joining device (5);
- rolling and joining, for the second coil (101b) and following coils, are subsequently repeated to perform the first-pass rolling by the cold rolling mill (1, 1a, 1b) and the joining of the tail end of a preceding coil and the leading end of a succeeding coil by the joining device (5), thereby building up a plurality of coils into one coil;
- 55
- reversible rolling of the build-up coil (102) is performed at the cold rolling mill (1, 1a, 1b) a predetermined number of times until a desired product strip thickness is reached; and
- the built-up coil (102) is cut by a cutting device (7a, 7b) and the cut coils are wound onto either of the first and second winding/unwinding devices (3, 4) to form a plurality of coils (103a to 103c).

EP 2 500 114 A1

16. The reversible cold rolling equipment according to claim 15,
wherein a strip storage device (9) is disposed between the joining device (5) and the cold rolling mill (1, 1a, 1b).

5 17. The reversible cold rolling equipment according to claim 16,
wherein the length of a strip stored at the strip storage device (9) is more than 0 m and not more than 100 m.

10 18. The reversible cold rolling equipment according to any one of claims 15 to 17,
wherein the controller (20) controls rolling speeds at the cold rolling mill (1, 1a, 1b) during coil joining by the joining
device (5) and at the time of coil cutting by the cutting device (7a, 7b) to a value of more than 0 mpm and not more
than 50 mpm.

15 19. The reversible cold rolling equipment according to any one of claims 15 to 18,
wherein the controller (20) performs a strip thickness control such that during coil joining by the joining device (5)
and at the time of coil cutting by the cutting device (7a, 7b), entry-side rolling speed and entry-side strip thickness
and delivery-side rolling speed at the cold rolling mill (1, 1a, 1b) are measured, the strip thickness beneath work
rolls of the cold rolling mill (1, 1a, 1b) is computed based on the measured values, and a strip thickness control such
as to obtain a desired strip thickness is performed by a hydraulic rolling reduction device (14) possessed by the cold
rolling mill.

20 20. The reversible cold rolling equipment according to any one of claims 15 to 19,
wherein the controller (20) controls strip shape by a roll bender control or a coolant control or a combination of both
controls on the basis of the computation result of roll deflection due to fluctuations in rolling load at the cold rolling
mill (1, 1a, 1b), during coil joining by the joining device (5) and at the time of coil cutting by the cutting device (7a, 7b).

25 21. The reversible cold rolling equipment according to any one of claims 15 to 20,
wherein the controller (20) sets a tension on a strip when a coil outside diameter is larger to be gradually lower as
compared with a tension on the strip when the coil outside diameter is smaller, during the coil building-up and rolling
in the first pass and the subsequent reversible rolling.

30 22. The reversible cold rolling equipment according to any one of claims 15 to 21,
wherein the cold rolling mill (1a, 1b) is of a two-stand type.

35 23. The reversible cold rolling equipment according to any one of claims 15 to 22,
wherein the joining device (5) is a mash seam welding machine.

40 24. The reversible cold rolling equipment according to claim 23,
wherein the mash seam welding machine as the joining device (5) comprises a swaging roller (53) having a mech-
anism (60) for inclining a swaging roller axis relative to a horizontal plane perpendicular to a joining line.

FIG. 1

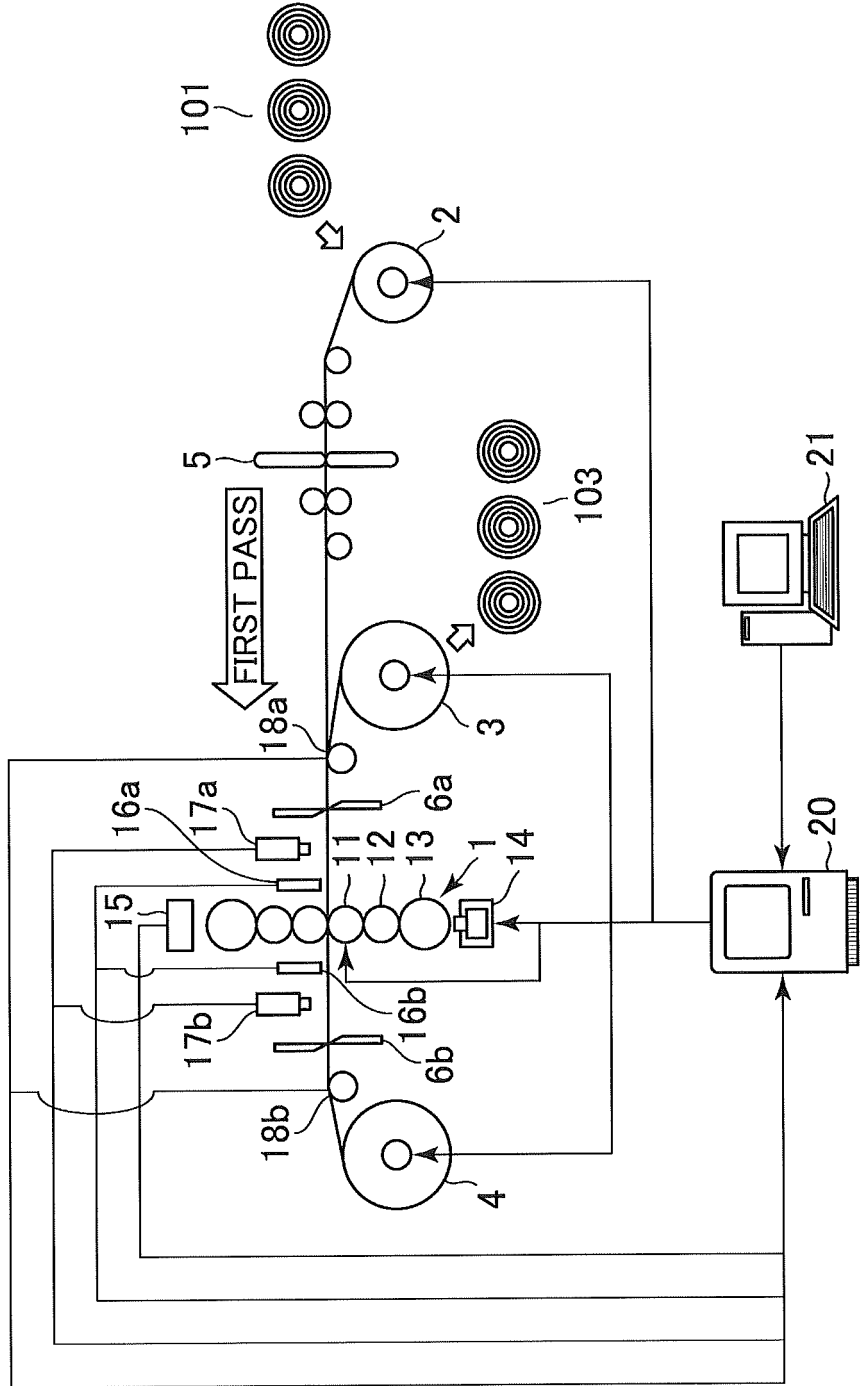

FIG. 2

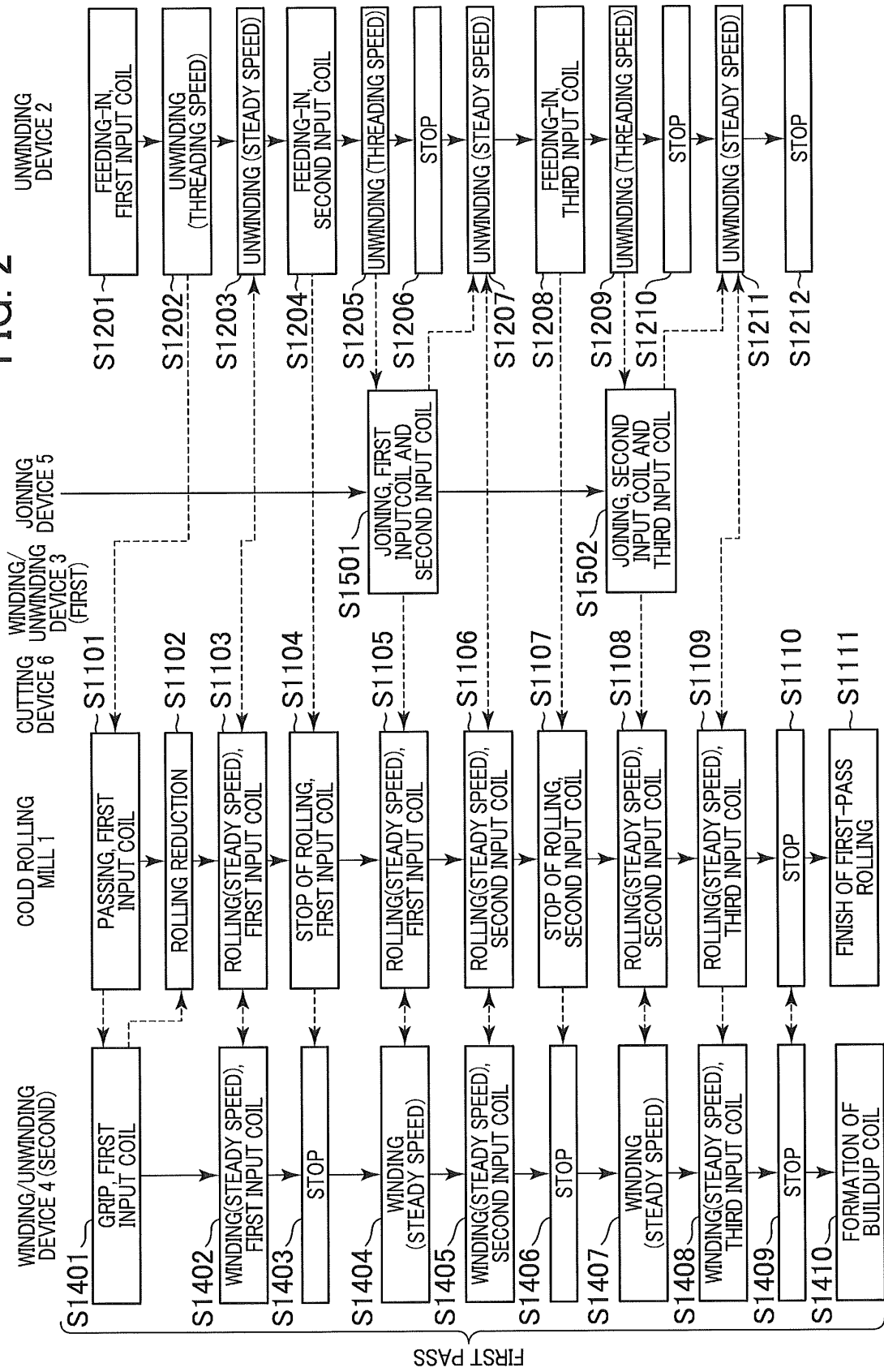

FIG. 3

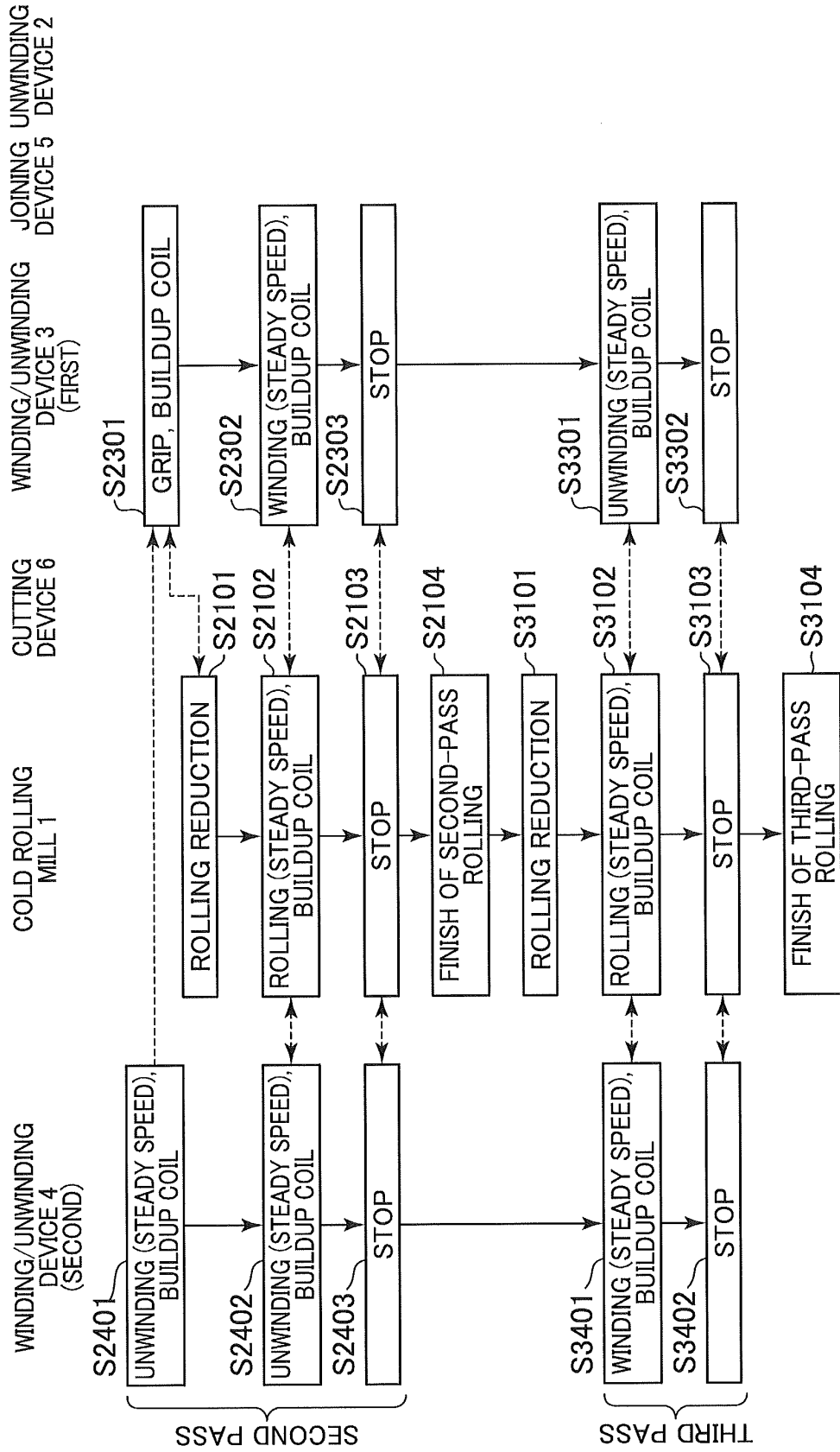
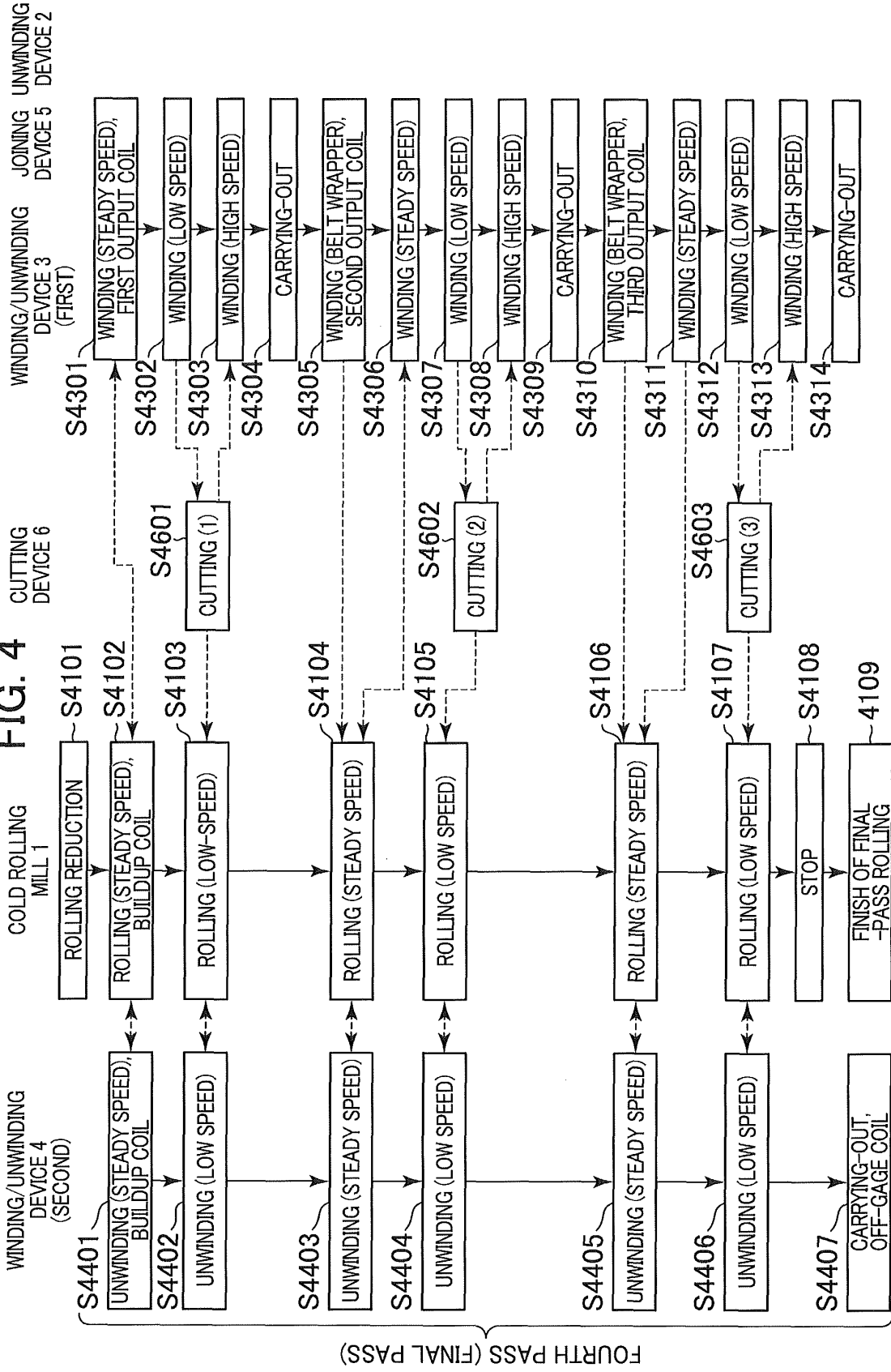

FIG. 4



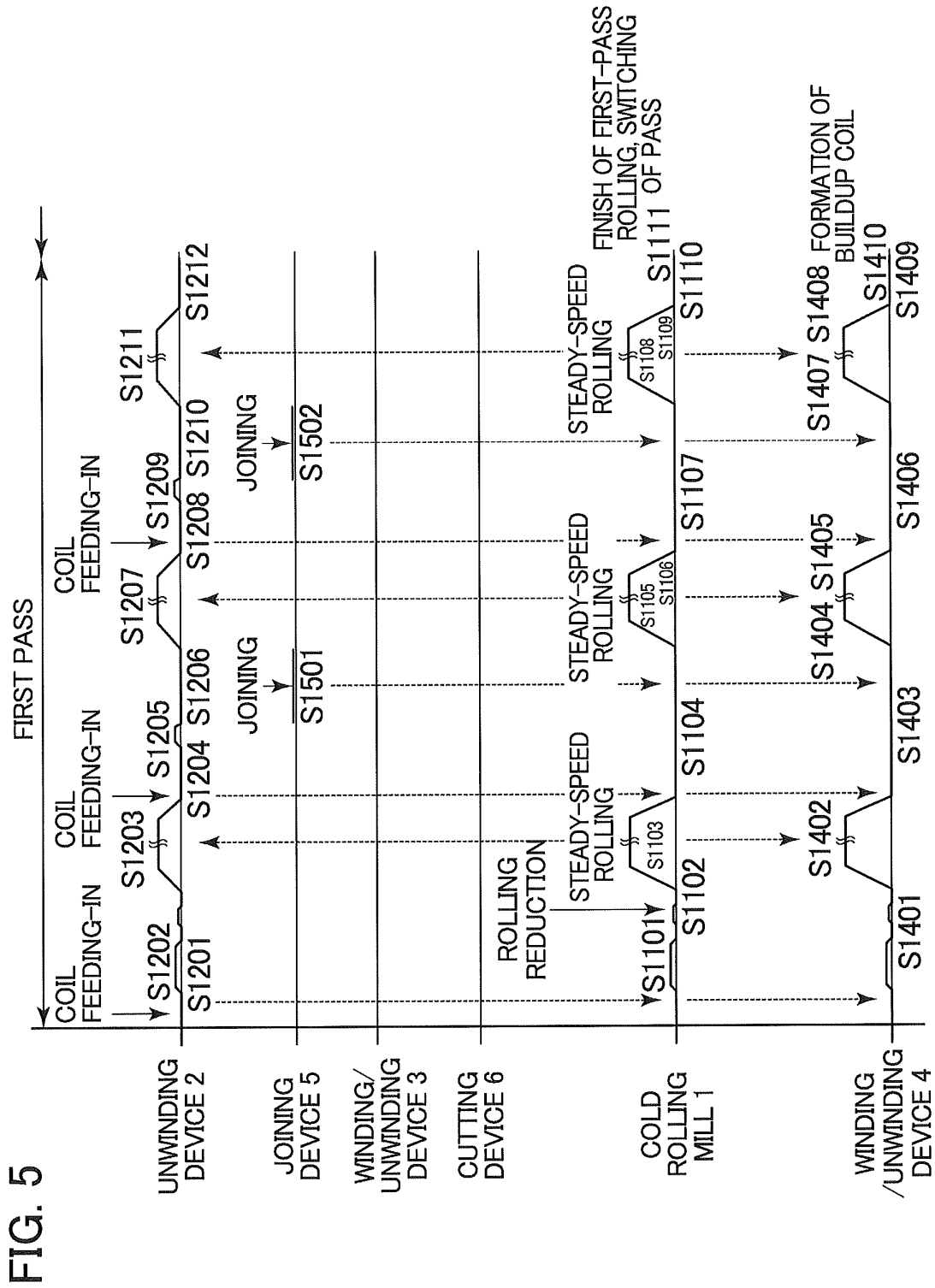

FIG. 5

FIG. 6

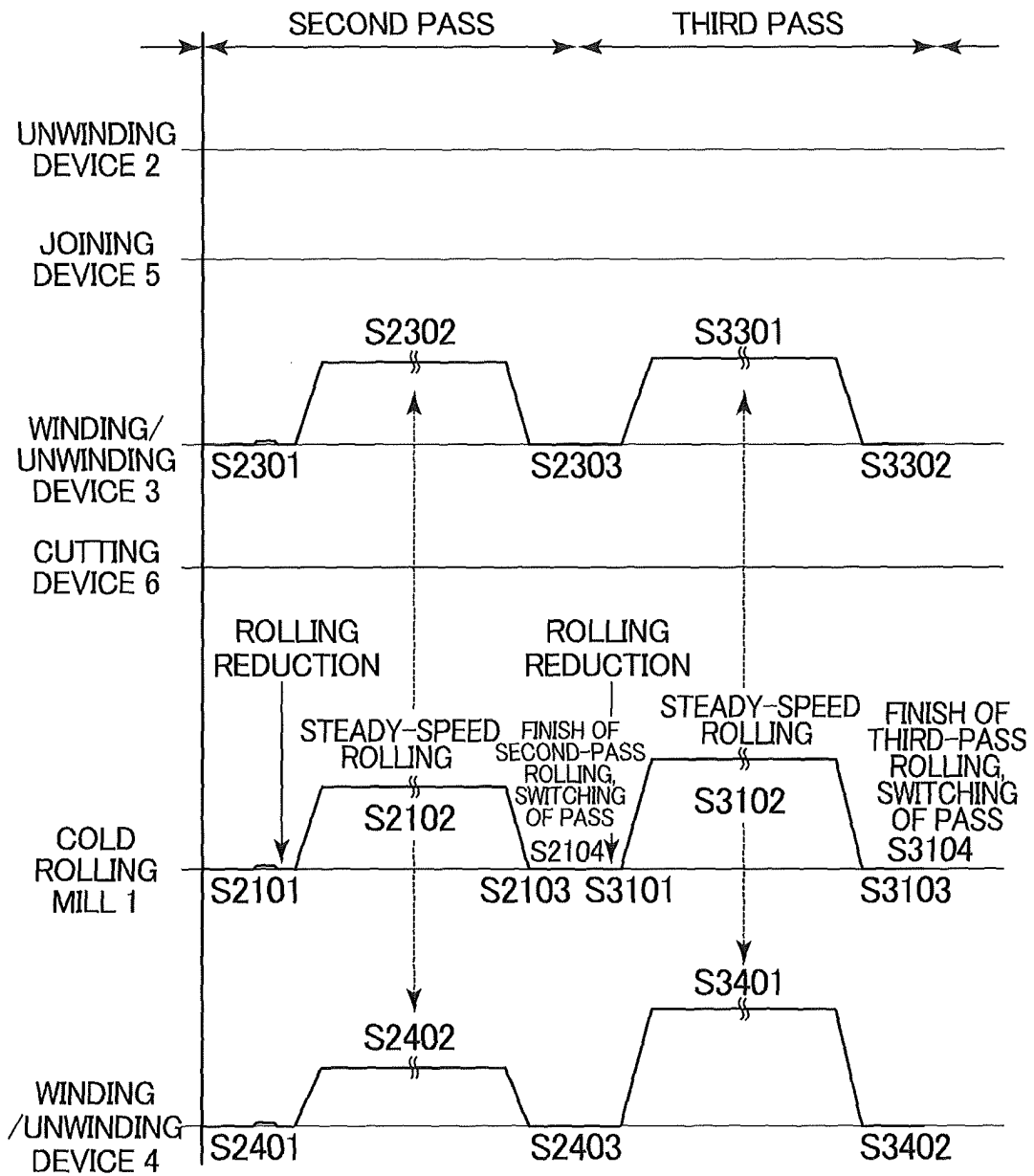

FIG. 7

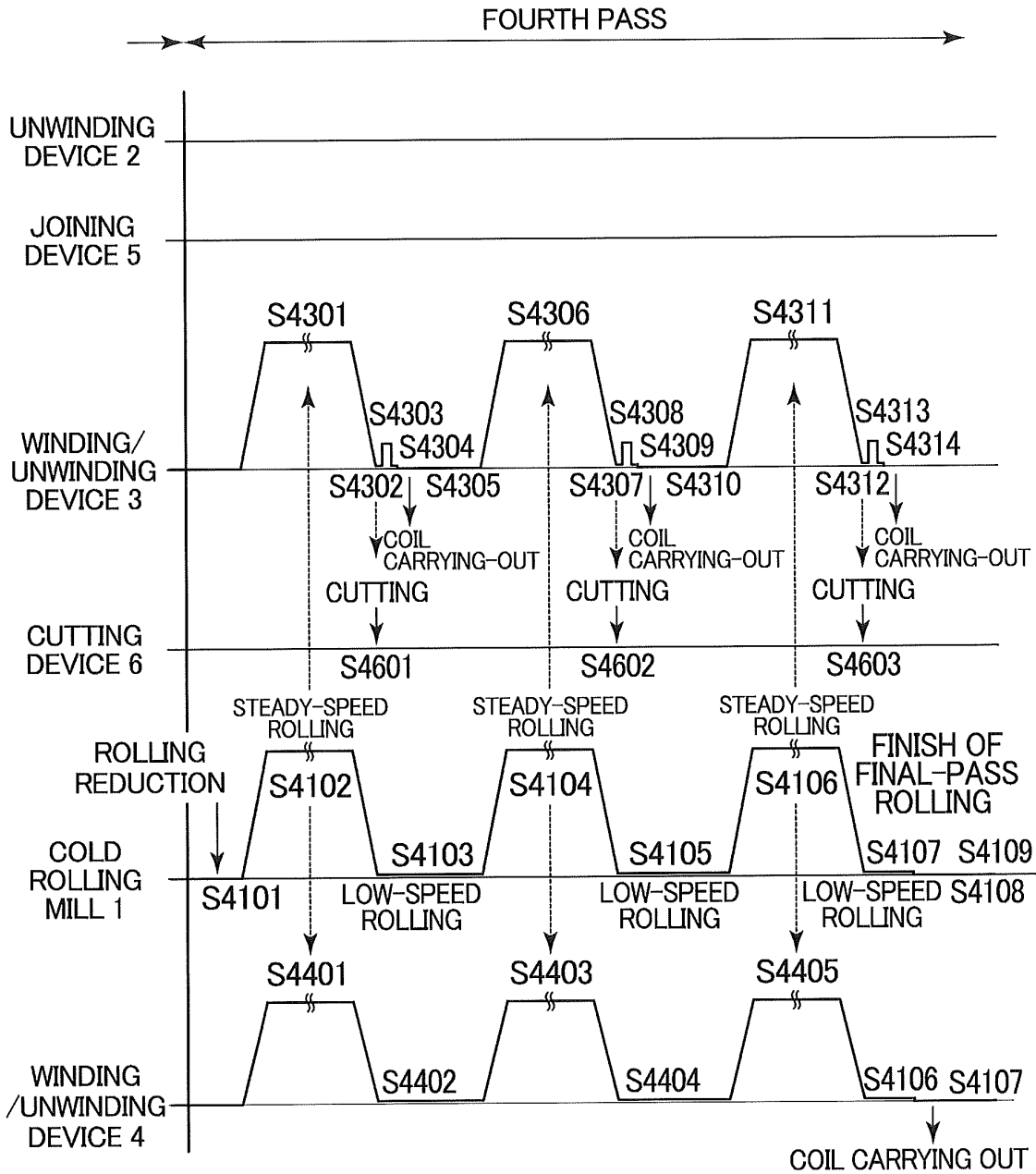

FIG. 8

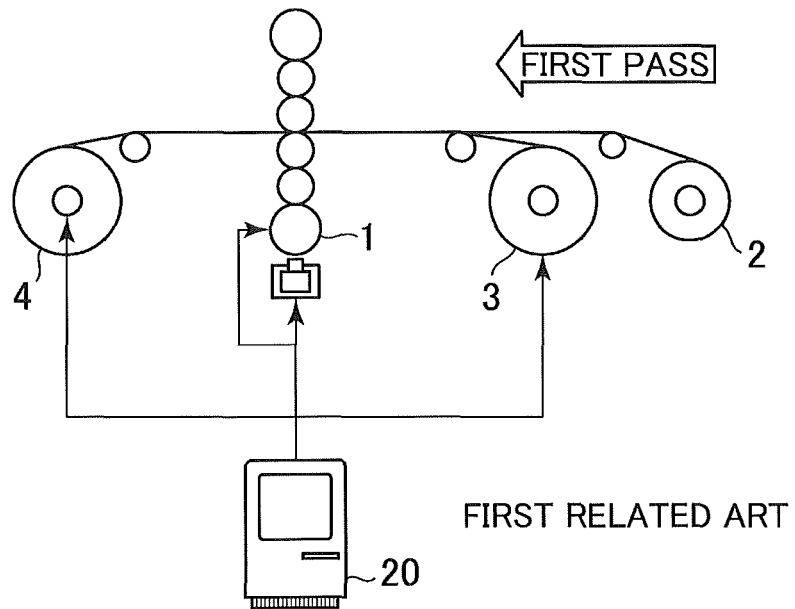

FIG. 9

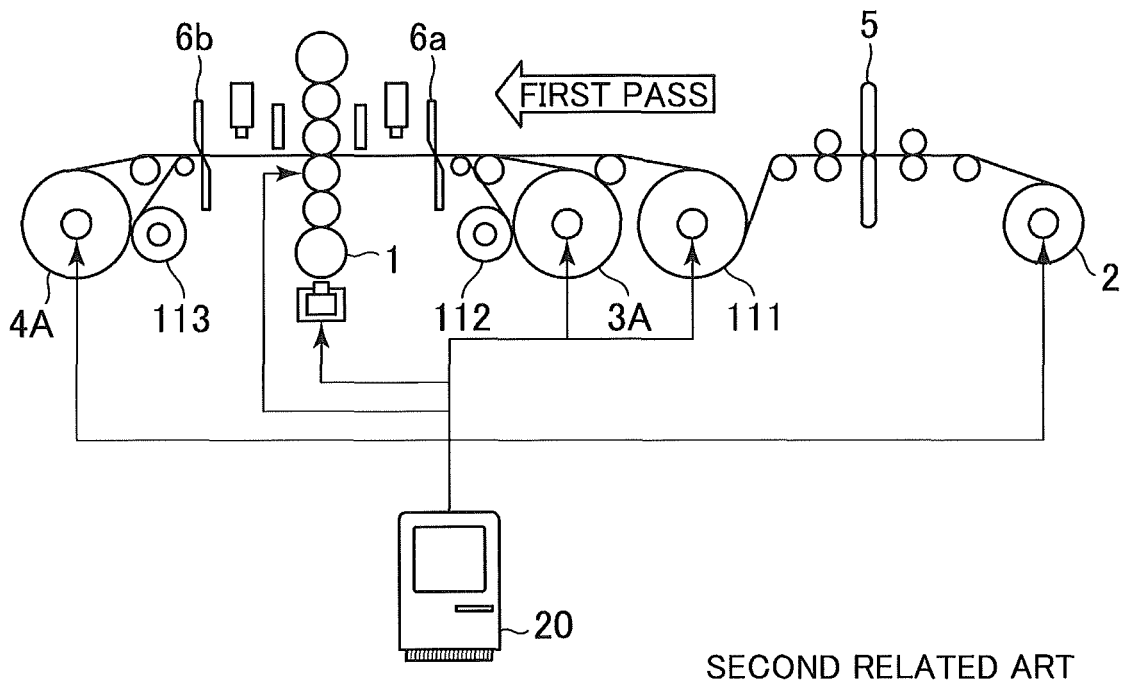

FIG. 10

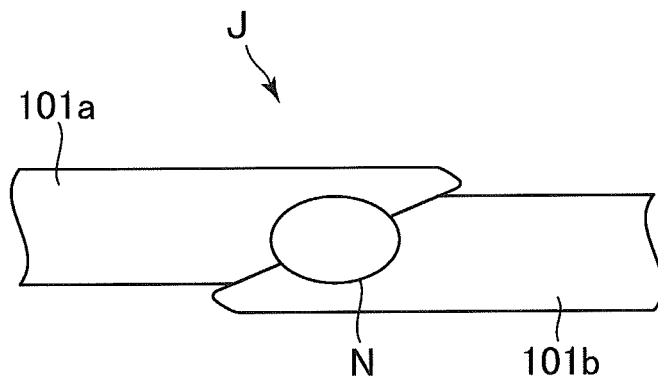

FIG. 11

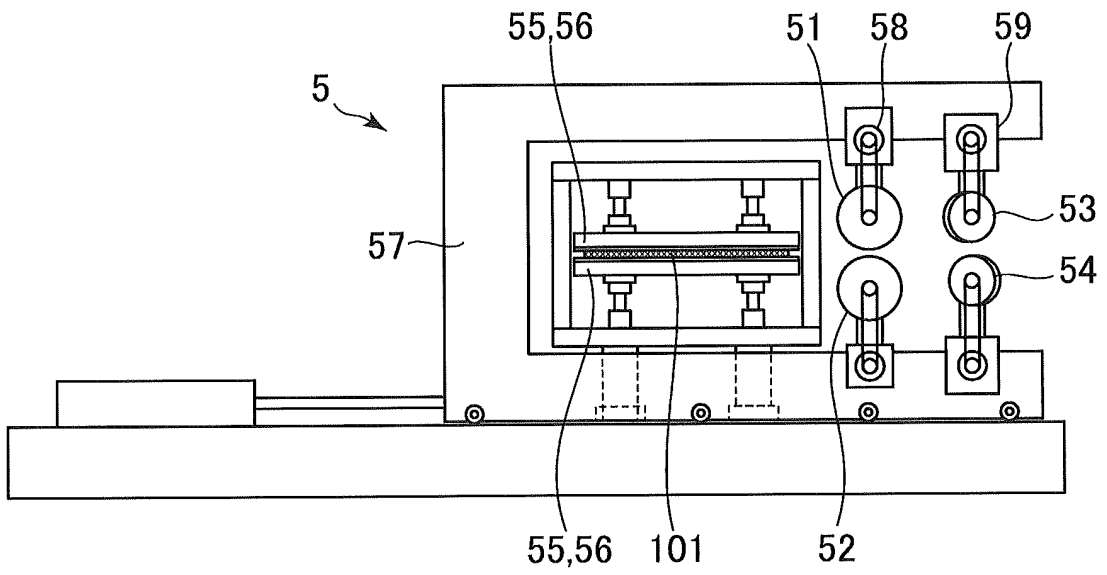

FIG. 12

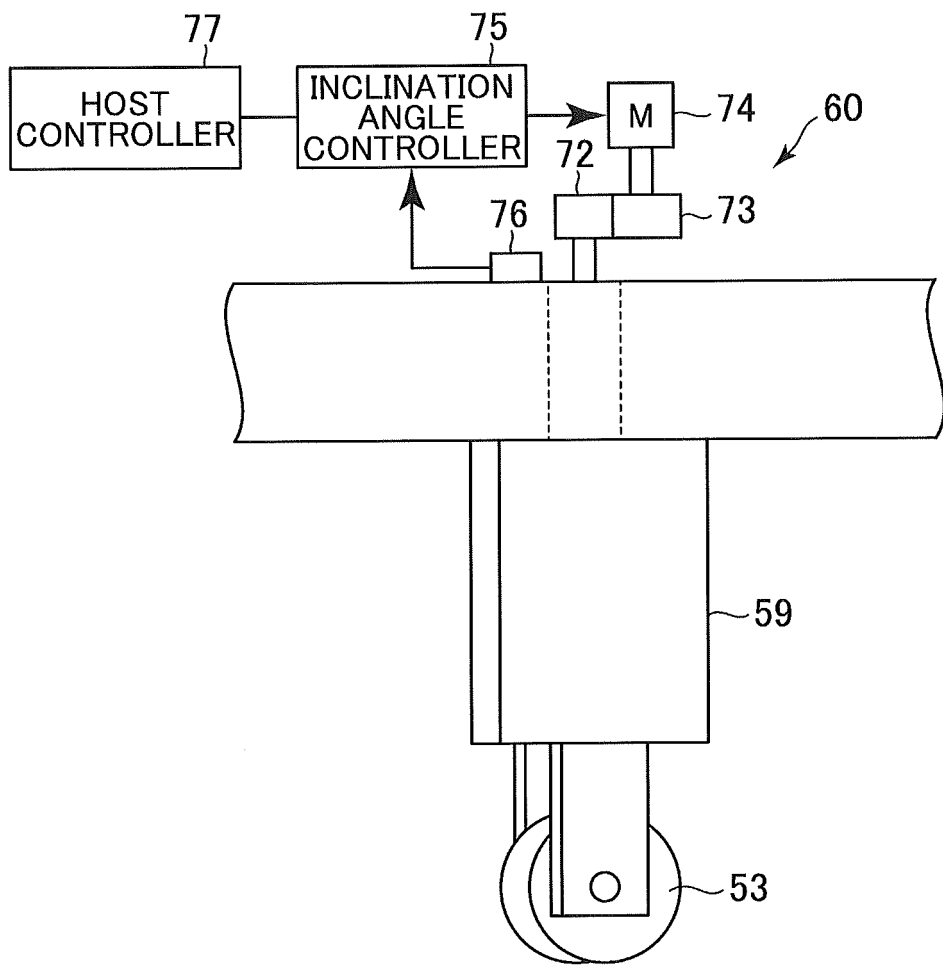

FIG. 13

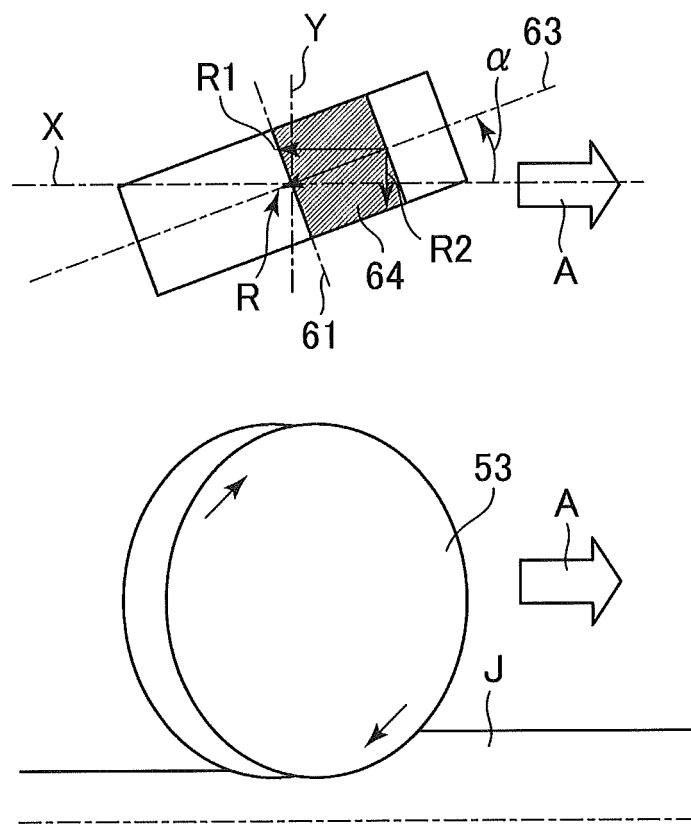

FIG. 14

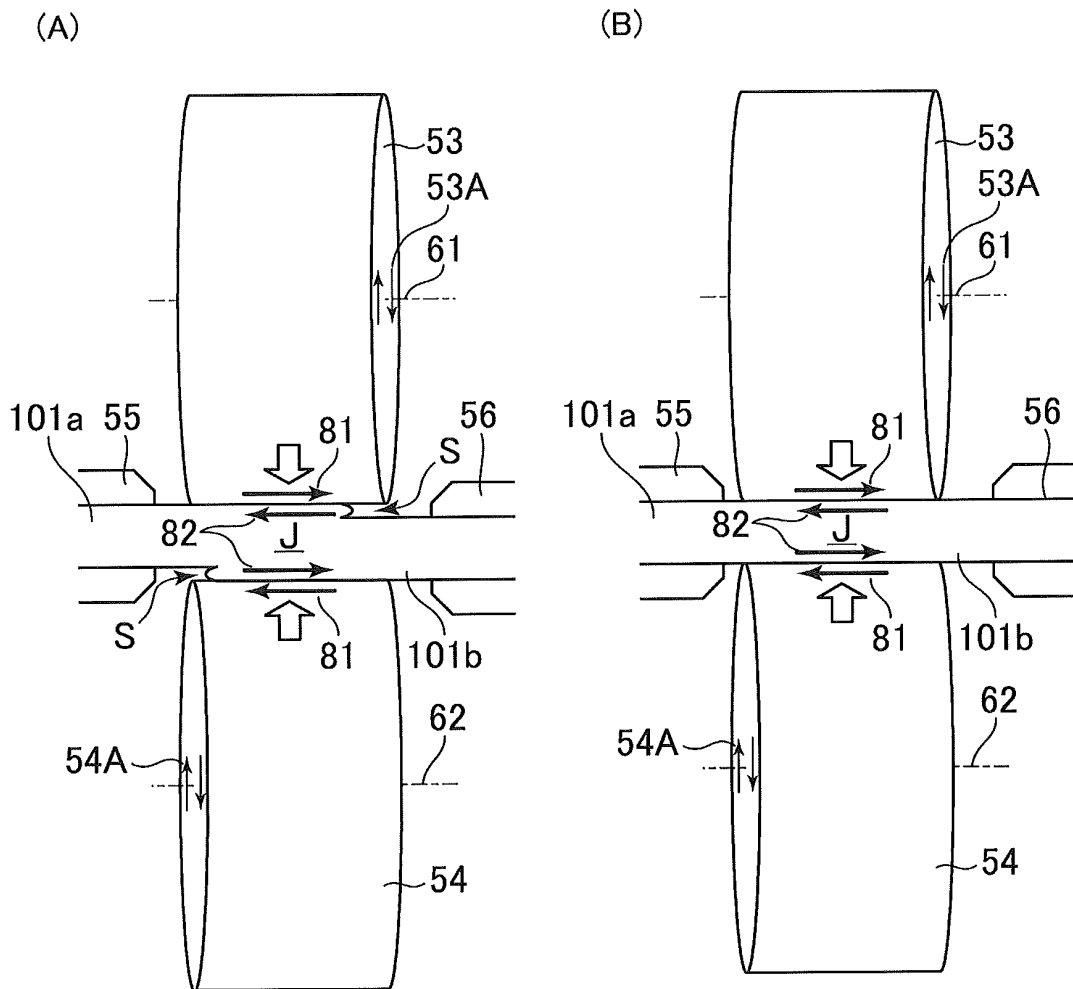

FIG. 16

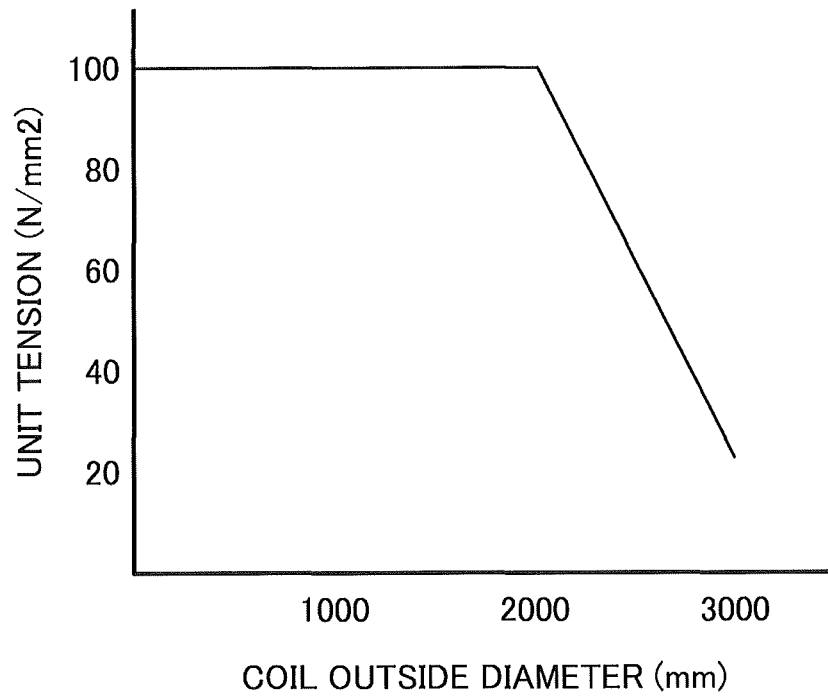

FIG. 17

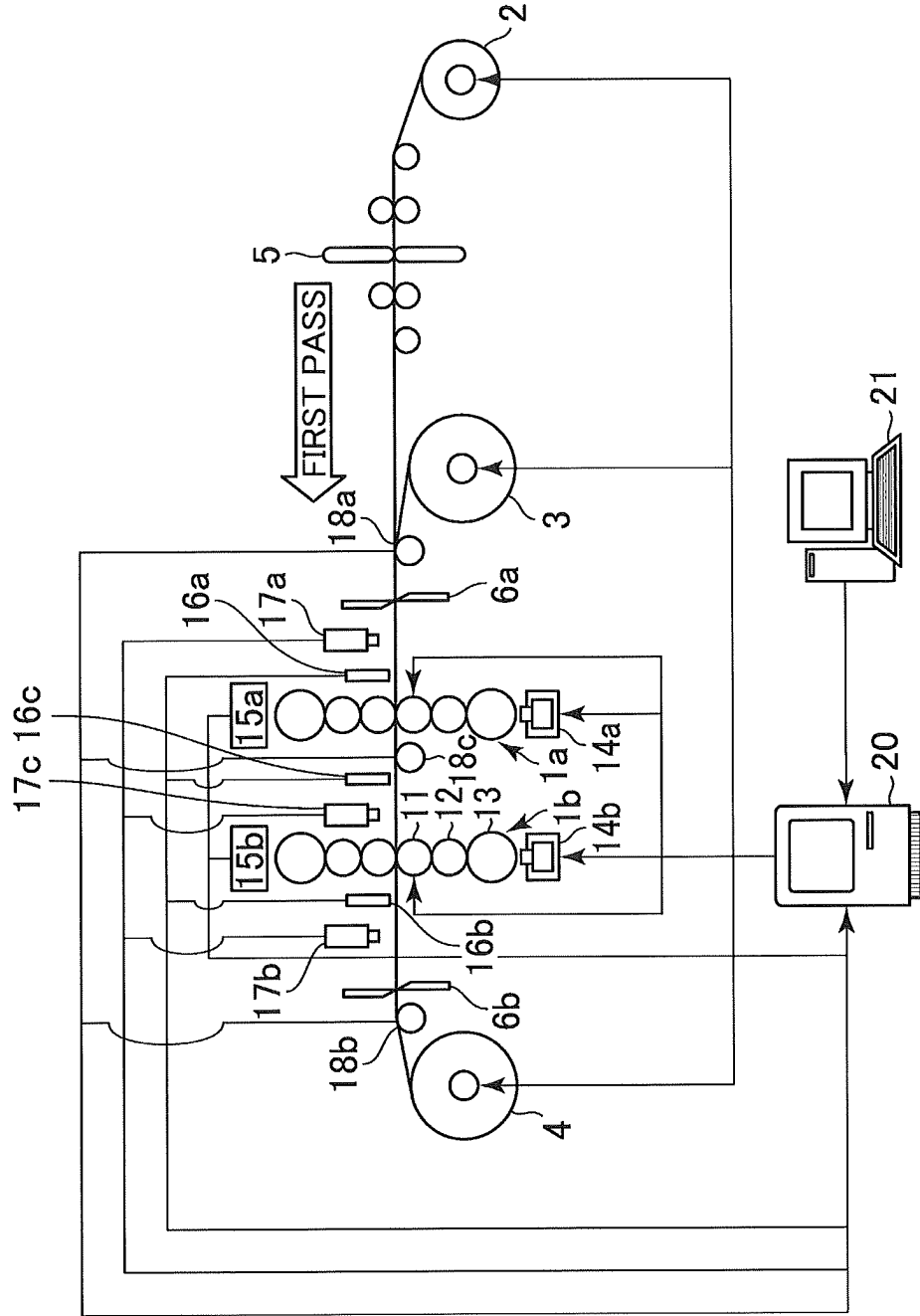

FIG. 18

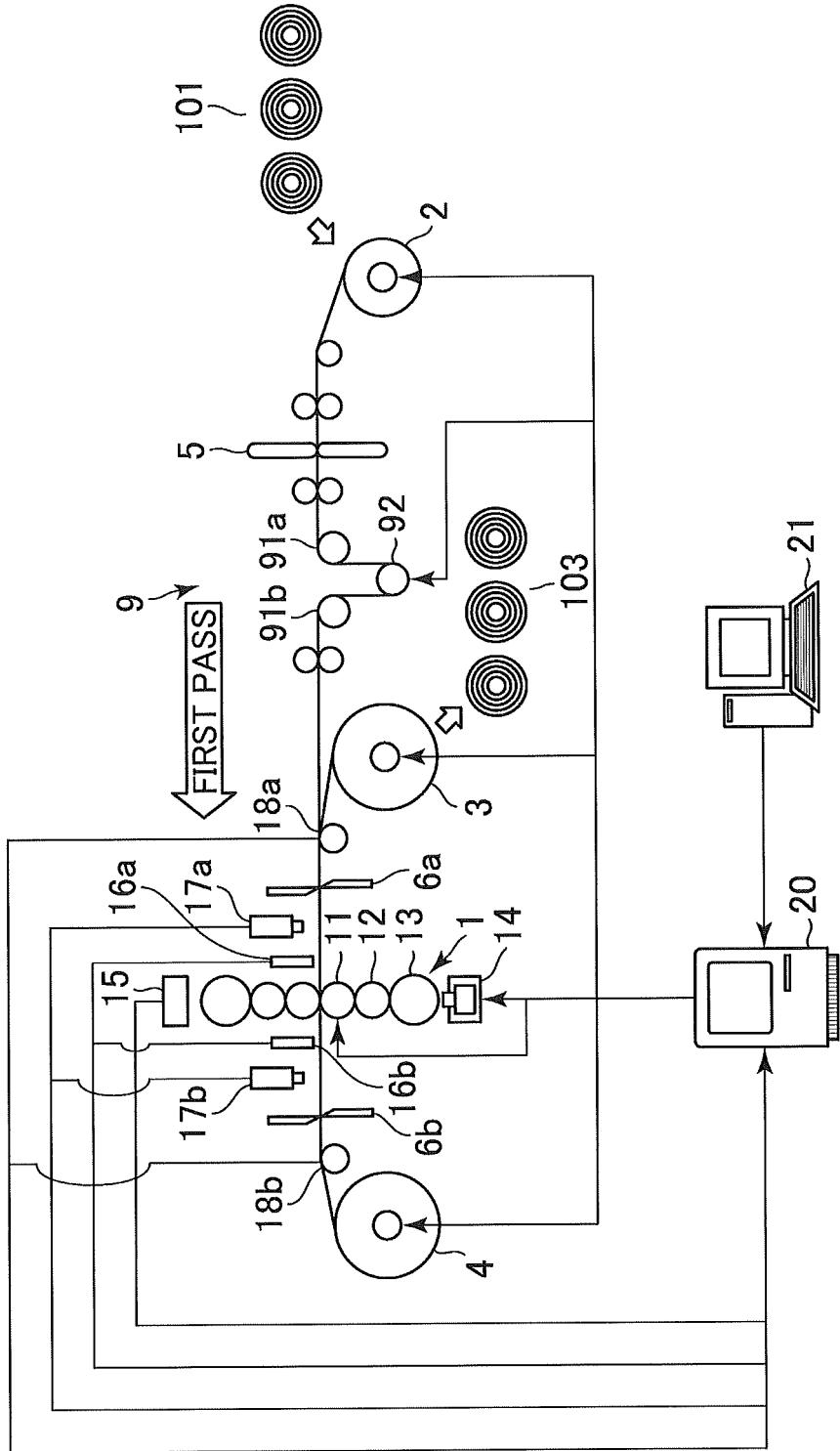

FIG. 19

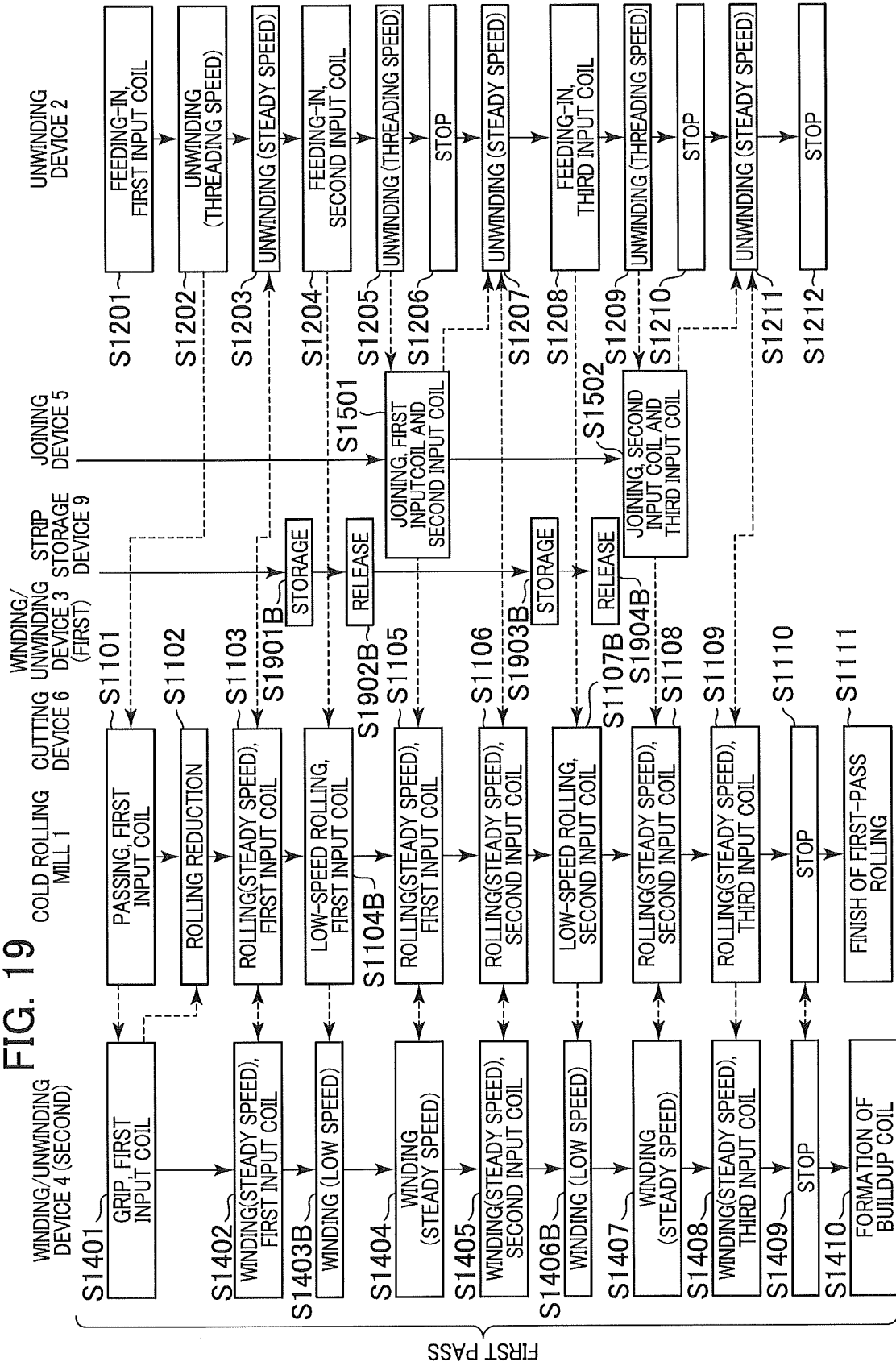
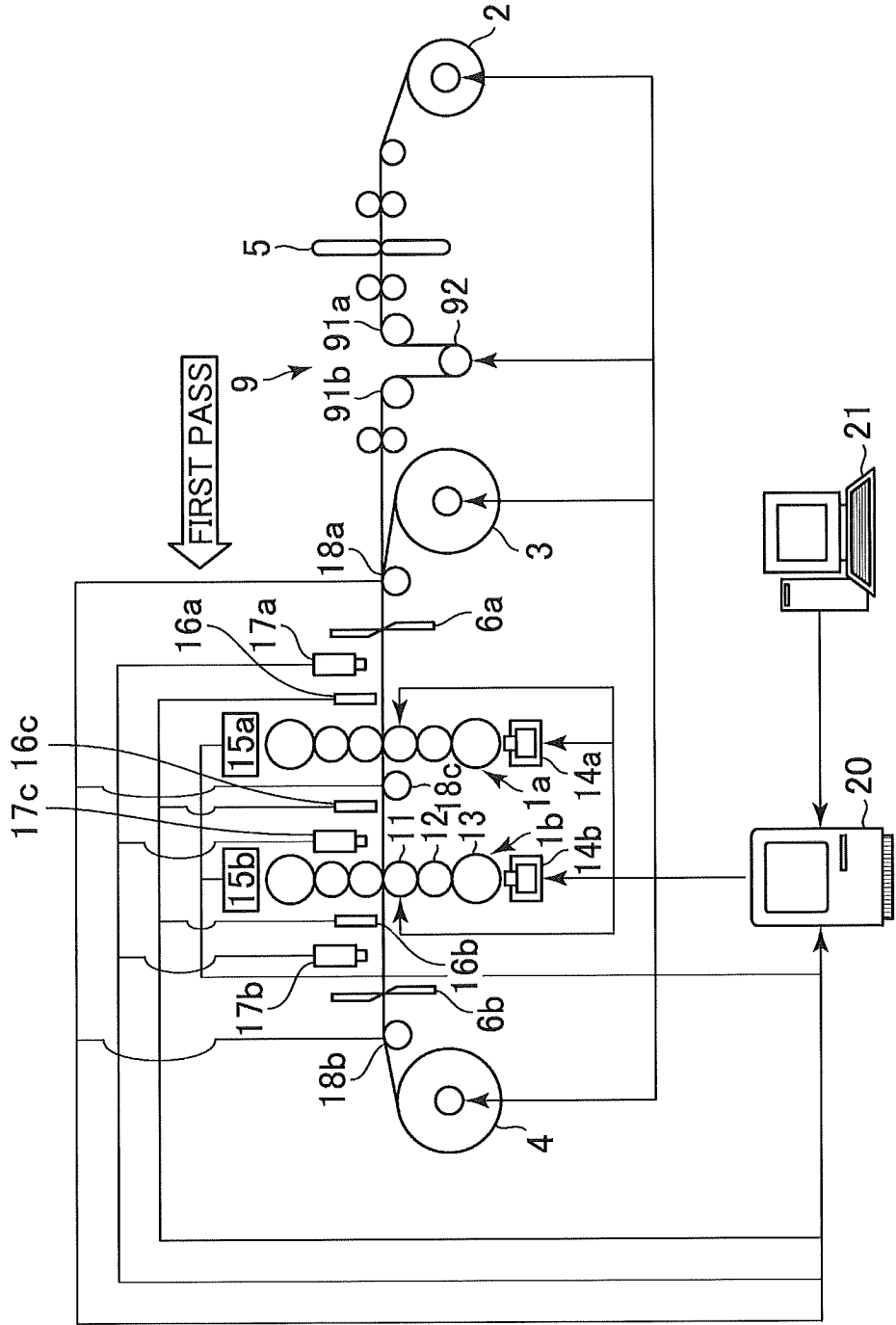

FIG. 20



INTERNATIONAL SEARCH REPORT

International application No.

PCT/JP2009/069064

A. CLASSIFICATION OF SUBJECT MATTER B21B1/36(2006.01) i, B21B15/00(2006.01) i, B21B37/18(2006.01) i, B21B37/32(2006.01) i, B21B37/38(2006.01) i, B21B41/00(2006.01) i		
According to International Patent Classification (IPC) or to both national classification and IPC		
B. FIELDS SEARCHED		
Minimum documentation searched (classification system followed by classification symbols) B21B1/36, B21B15/00, B21B37/18, B21B37/32, B21B37/38, B21B41/00		
Documentation searched other than minimum documentation to the extent that such documents are included in the fields searched Jitsuyo Shinan Koho 1922-1996 Jitsuyo Shinan Toroku Koho 1996-2009 Kokai Jitsuyo Shinan Koho 1971-2009 Toroku Jitsuyo Shinan Koho 1994-2009		
Electronic data base consulted during the international search (name of data base and, where practicable, search terms used)		
C. DOCUMENTS CONSIDERED TO BE RELEVANT		
Category*	Citation of document, with indication, where appropriate, of the relevant passages	Relevant to claim No.
A	JP 52-5649 A (Hitachi, Ltd.), 17 January 1977 (17.01.1977), claims; drawings & US 4123011 A & DE 2606301 A & BR 7600988 A	1-24
A	JP 2006-334647 A (Steel Plantech Co.), 14 December 2006 (14.12.2006), claims (Family: none)	1-24
<input type="checkbox"/> Further documents are listed in the continuation of Box C. <input type="checkbox"/> See patent family annex.		
* Special categories of cited documents: "A" document defining the general state of the art which is not considered to be of particular relevance "E" earlier application or patent but published on or after the international filing date "L" document which may throw doubts on priority claim(s) or which is cited to establish the publication date of another citation or other special reason (as specified) "O" document referring to an oral disclosure, use, exhibition or other means "P" document published prior to the international filing date but later than the priority date claimed "I" later document published after the international filing date or priority date and not in conflict with the application but cited to understand the principle or theory underlying the invention "X" document of particular relevance; the claimed invention cannot be considered novel or cannot be considered to involve an inventive step when the document is taken alone "Y" document of particular relevance; the claimed invention cannot be considered to involve an inventive step when the document is combined with one or more other such documents, such combination being obvious to a person skilled in the art "&" document member of the same patent family		
Date of the actual completion of the international search 16 December, 2009 (16.12.09)		Date of mailing of the international search report 28 December, 2009 (28.12.09)
Name and mailing address of the ISA/ Japanese Patent Office		Authorized officer
Facsimile No.		Telephone No.

Form PCT/ISA/210 (second sheet) (April 2007)

REFERENCES CITED IN THE DESCRIPTION

This list of references cited by the applicant is for the reader's convenience only. It does not form part of the European patent document. Even though great care has been taken in compiling the references, errors or omissions cannot be excluded and the EPO disclaims all liability in this regard.

Patent documents cited in the description

- JP 3322984 B [0008]
- JP SHO57039844 B [0008]