

C. BOURGEOIS.

Improvement in Beer-Faucets.

No. 129,090.

Patented July 16, 1872.

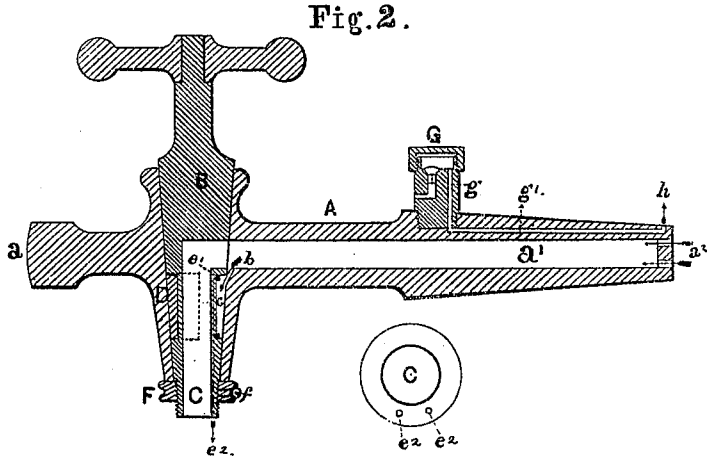
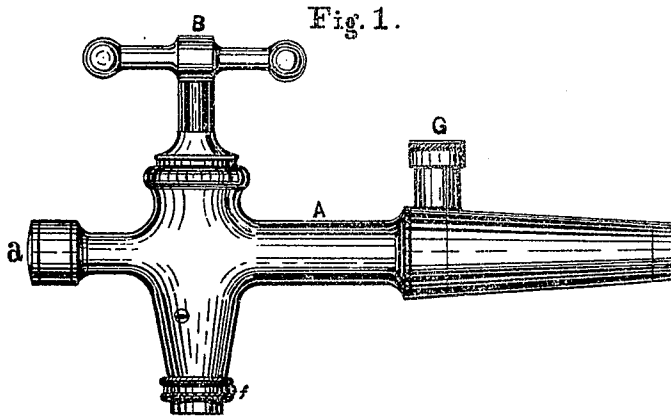

WITNESSES.

Frank Collignon
Victor Hu Becker

Inventor.

Chas. Bourgeois

C. BOURGEOIS.

Improvement in Beer-Faucets.

No. 129,090.

Patented July 16, 1872.

Fig. 3

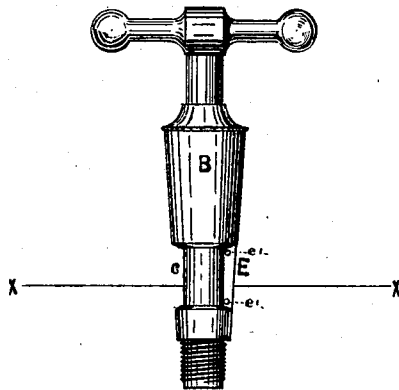

Fig. 4

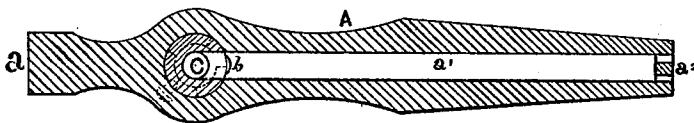

Fig. 5

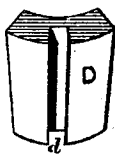
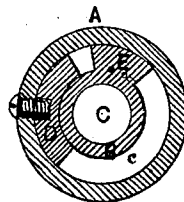

Fig. 6



WITNESSES.

Frank Collignon
Victor H. Beckes

Inventor.

Chas. Bourgeois

UNITED STATES PATENT OFFICE.

CHARLES BOURGEOIS, OF BUFFALO, NEW YORK.

IMPROVEMENT IN BEER-FAUCETS.

Specification forming part of Letters Patent No. 129,090, dated July 16, 1872.

SPECIFICATION.

I, CHARLES BOURGEOIS, of the city of Buffalo, in the county of Erie and State of New York, have invented an Improved Beer-Faucet, of which the following is a specification:

My improvements relate to that class of faucets which operate to force or agitate the liquid as it passes from the cask into the glass or other vessel. This is usually accomplished by forcing a jet of air into the liquid to produce agitation, which is very injurious to beer, ale, &c., making it stale and flat. The forcing is accomplished in my improved faucet by compressing a small portion of the liquid in a chamber formed in the key of the faucet and forcing it into the main stream before it reaches the glass or other vessel; and the invention consists, first, in forming a groove on the key below the hole of the faucet in such a manner that it shall not extend the whole distance around the key, but leave a projection or stop thereon. Into this groove is fitted a small segment, which is held to the seat of the faucet by a screw in such a manner that it cannot turn with the key, but is free to work down with it as it wears, thus forming a chamber in the key, which communicates with the hole of the faucet, when it is closed, by a small groove or slot cut therefrom. From this chamber small holes are drilled, which lead to the bottom of the key, where the small stream of liquid is discharged into the large one, agitating and forcing it; second, in forming a horizontal passage immediately above the outlet-opening, beginning at or near the center of the faucet and terminating in a vertical opening at the rear of the same, for the reception of a vent.

In the accompanying drawing—which is made half size, excepting Figures V and VI, which are made full size—Figure I is a side elevation. Fig. II is a vertical longitudinal section. Fig. III is a side elevation of the key. Fig. IV is a horizontal section. Fig. V is a perspective view of the small segment. Fig. VI is a section on line *x x*, Fig. III.

Like letters of reference designate like parts in each of the figures.

A is the faucet, which is provided with a head, *a*. *a*¹ is the bore, provided at its end with a perforated strainer, *a*², to prevent any pieces from entering and clogging up the faucet. B is the key. C is its discharge-hole.

c is the groove, both sides of which are made tapering. This groove communicates with the hole *a*¹ of the faucet by a small groove or slot, *b*, as shown in Figs. II and IV. D is the segment, which is made to fit and is ground into the groove *c*, and is provided with a small slot, *d*, into which a screw is inserted from the outside, through a hole tapped in the faucet, as shown in dotted lines, Fig. IV. This screw holds the segment from turning with the key, but allows it to work down with it as it wears. E is the stop which forms one side of the chamber *c*, and also prevents the key from being turned more than is necessary. *e*¹ *e*¹ and *e*² are the small holes through which the liquid is forced into the large stream. F is a nut which holds the key from working up from its tapering seat, and is kept from turning on the key by a set-screw, *f*. G is the vent, and *g* and *g*¹ are the passages leading to the cask. The pressure of the atmosphere is sufficient to force the air through the body of the liquid. The passage *h*, it is found, must be drilled vertically, and the horizontal passage *g*¹ must be drilled above and parallel with the bore of the faucet.

The operation of my improved faucet will be readily understood. The faucet is closed and the chamber *c* is filled with the liquid through the slot *b*, as shown by the arrows, Fig. II. Now, on turning the key to the left, the liquid is allowed to flow through the hole C into the vessel, while at the same time the chamber *c* is being contracted or made narrower by the turning of the stop E against the stationary segment D, which forces the liquid through the small holes *e*¹ *e*¹ and *e*² into the stream coming from the passage C and agitates it to such an extent as to give it a fresh and foaming appearance.

I lay no claim to the vent itself.

Claims.

1. The combination of the slot *b* with the expanding and contracting chamber *c*, holes *e*¹ *e*¹ and *e*², stationary segment D, and stop E, substantially as described.

2. The combination of a vent with a faucet, substantially as described, having the passages *g*¹ and *h* arranged as shown.

Witnesses: CHAS. BOURGEOIS.
FRANK COLLIGON,
VICTOR H. BECKER.