

*H. Tilden,*  
*Flour Sieve.*

*N<sup>o</sup> 51,881.*

*Fig. 1 Patented Jan. 2, 1866.*

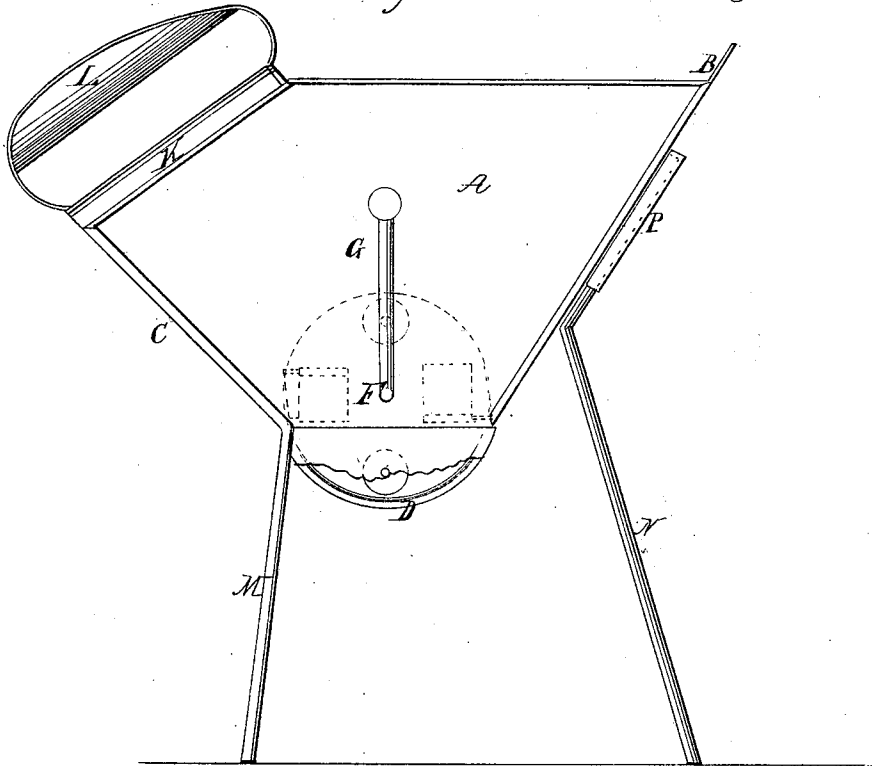

*Fig. 2*

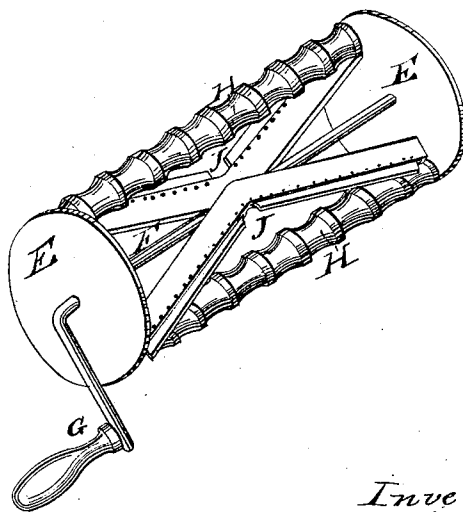

*Witnesses:*  
*J. E. Dennis*  
*Wm. M. Woods*

*Inventor:*  
*Howard Tilden*  
*By his Attorney J. Dennis Jr.*

# UNITED STATES PATENT OFFICE.

HOWARD TILDEN, OF BOSTON, MASSACHUSETTS.

## FLOUR-SIFTER.

Specification forming part of Letters Patent No. 51,881, dated January 2, 1866.

*To all whom it may concern:*

Be it known that I, HOWARD TILDEN, of Boston, Suffolk county, State of Massachusetts, have invented certain new and useful Improvements in Flour-Sifters; and I do hereby declare the following description and accompanying drawings are sufficient to enable any person skilled in the art or science to which it most nearly appertains to make and use my said invention or improvements without further invention or experiment.

The nature of my invention and improvements consists in the combination, construction, and arrangement of devices hereinafter described in this specification, and represented in the drawings.

In the accompanying drawings, Figure 1 is an elevation of one side of the flour-sifter, a small portion of the lower edge of the side being omitted to show the screen. Fig. 2 is an elevation of the shaft, disks, rollers, and scrapers.

In these drawings a scooped-shaped box is shown, of which A is the side, B the front, C the rear, and D a screen of wove wire connecting the front and rear and forming the bottom or lowest part of the box, which is made just wide enough for the disks E E on the shaft F to turn freely in it. The sides B are perforated for the journals of the shaft F to turn in, and it is provided with a crank, G, by which it is rotated.

The flour, when it is put in this sifter, is agitated and worked through the screen by rollers and scrapers carried by the disks E E. The rollers H H are grooved roundwise and provided with journals at their ends which turn in perforations in the disks E as they roll around on the inside of the screen D to work the plow through the screen. The scrapers I I are made of sheet-metal, folded together, with india-rubber put between the edges and made to project so far as to form a flexible scraper to work the flour through the screen when the scrapers are carried around by the disks. The edges of the metal plates are pressed together on the rubber and then indented or

punched into the rubber to hold it fast. These scrapers are bent midway between the ends, so as to stand at an angle with the disks or spirally to the shaft, as shown in Fig. 2. There is an opening, J, in the rubber for the dead flies, worms, and excrements of rats and mice, or other impurities in the flour gathered by the scrapers to pass through, so as not to be crushed by the scrapers and worked through the screen. If the crank is turned backward the impurities would pass between the ends of the rubbers and the disks to which the plates of scrapers are fastened. The grooves in the rollers are made roundwise, so that the foreign substances above mentioned may slip into the grooves and not be crushed and worked through the screen with the flour; and one groove in each roller should be right opposite to the opening J between the scrapers, so that the rollers will pass over the impurities gathered to the middle without mashing them.

This sifter is partially covered by the arched top K fastened to the sides and rear C, and the front end of the handle L is fastened to this cover. (Shown in the drawings.)

This sifter is supported by three legs, two of which are fastened to the two rear corners, one of which is shown at M. The upper end of the leg N slips into the bracket P fastened to the front B, so that it (the leg) can be slipped out of the bracket and removed when a scoop-full of flour is dipped up to be sifted, when the leg may be replaced to support the sifter in a dish or on a board while the crank is turned to sift the flour.

I claim—

1. Grooving the rollers roundwise, so that coarse pieces of foreign matter will slip into the grooves without being crushed between the rollers and the screen.

2. The rollers, grooved roundwise, in combination with the inclined scrapers.

HOWARD TILDEN.

Witnesses:

H. P. TILDEN,  
WM. H. WARNE.