

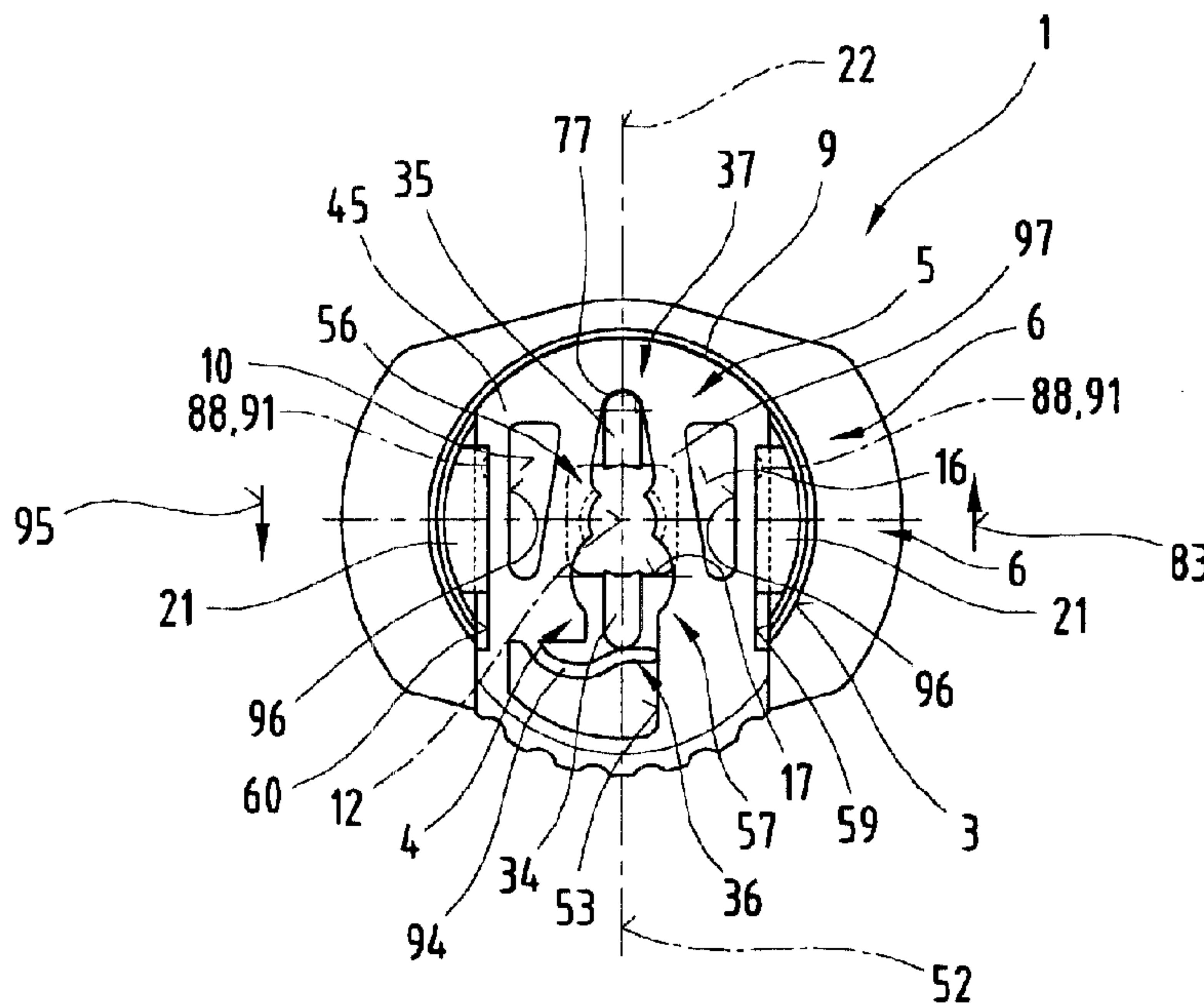

(86) Date de dépôt PCT/PCT Filing Date: 1999/12/21
 (87) Date publication PCT/PCT Publication Date: 2000/07/06
 (85) Entrée phase nationale/National Entry: 2001/06/18
 (86) N° demande PCT/PCT Application No.: AT 99/00306
 (87) N° publication PCT/PCT Publication No.: WO 00/38566
 (30) Priorité/Priority: 1998/12/23 (A 2165/98) AT

(51) Cl.Int.⁷/Int.Cl.⁷ A61M 5/34
 (71) Demandeur/Applicant:
GREINER BIO-ONE GMBH, AT
 (72) Inventeur/Inventor:
KONRAD, FRANZ, AT
 (74) Agent: RICHES, MCKENZIE & HERBERT LLP

(54) Titre : DISPOSITIF DE RECEPTION POUR UN ELEMENT RAPPORTE
 (54) Title: RECEIVING UNIT FOR AN ATTACHMENT



(57) **Abrégé/Abstract:**

The invention relates to a receiving unit (1) for an attachment, comprising a receiving body, a retaining device (4) and an actuation device (5) by means of which the retaining device (4) can be moved from a locked position into a release position. By means of a guide device (6) the actuation device (5) can be displaced in relation to the receiving body in a plane which is vertical to a longitudinal central axis (12). The actuation device (5) consists of a single-piece plate-shaped sliding element (45) having an opening (53) which is aligned vertically to the above plane. The retaining device (4) is positioned inside the opening (53) and a part of the opening (53) forms a retaining element (56) and another part a release element (57). At the outer surface (16) of one side of the receiving body at least two diametrically opposite support elements (34, 35) are positioned which protrude beyond the outer surface (16) of the wall in the direction of the side facing away from the interior space and in sections reach into the opening (53).

- 48 -

Abstract

The invention relates to a holding device (1) for an insert element with a holder body, a retaining device (4) and an operating device (5), by means of which the retaining device (4) can be displaced from a locked position into a released position. A guide device (6) enables the operating device (5) to be displaced relative to the holder body in a plane perpendicular to a longitudinal median axis (12). The operating device (5) is provided in the form of a single-piece, plate-shaped slide (45) with an orifice (53) therein, aligned perpendicular to the plane. Furthermore, the retaining device (4) is arranged in the orifice (53), one part of the orifice (53) forming a retaining element (56) and another part a releasing element (57). Provided on one wall of the holder body, on the external face (16) thereof, are at least two diametrically opposite supporting elements (34, 35), which project out from the external face (16) of the wall in the direction of the side remote from the interior chamber and engage in certain regions in the orifice (53).

Use Fig. 1 for abstract.

Receiving unit for an attachment

The invention relates to a holding device for an insert element, in particular for a needle assembly for drawing samples from body fluids, pieces of tissue or tissue cultures, as described in claim 1.

A known holding device for an insert element is known from US 5,755,673 A or WO 97/24067, in which the holding device comprises a holder container with end regions spaced at a distance apart, between which a container casing extends, the first end region being open and the other end region being closed off by an end wall. The container casing and the end wall bound an interior space and a retaining device is provided on the end wall in the area of the closed end region for an insert element which can be inserted in the holding device. An orifice extends through the end wall of the holder container, arranged more or less in the centre thereof, and the retaining device consists of retaining elements which can be adjusted in a counter-rotating movement by means of an operating member, so as to be displaced from a locked position into a released position. The operating member is provided in the form of a slide, which is mounted so as to be displaceable in a guide device in a direction parallel with the end wall. The retaining device and operating member are covered with a respective cover part on the side remote from the interior, preventing them from unintentionally working loose. The retaining device is operated by the operating member, which also causes the two retaining elements to pivot.

Another receiving device for an insert element, in particular a needle assembly, is known from US 5,797,490 A, which also comprises a holder container with end regions spaced at a distance apart with a container casing extending between them. Here too, the first end region is open and the other end region is closed off by an end wall. The retaining device for the insert element and an operating member for the retaining device, which is mounted so that it can be displaced relative to the holder container, are provided in the region of the end wall. The retaining device comprises two retaining elements, comprising two half shells with a matching screw thread. These two retaining elements are retained in a fixed position relative to the holder container by means of an immobilising member so that a first retaining element is held so as to be virtually non-slidable in a predetermined position relative to the holder container by means of a positioning member. The positioning member retains the second retaining element such that it can be displaced in a plane parallel with the end wall if necessary, and the two facing half shells form a closed mounting bore with an internal thread for the

- 2 -

needle assembly when in the locking position for the needle assembly. The other or second retaining element can be displaced from the locked position into the released position by means of another operating member by a sliding action in a direction parallel with the end wall.

The underlying objective of the present invention is to provide a holder container of the type described above, in which the operating mechanism is easy to operate with one hand and which enables the needle assembly to be securely and firmly retained in the locked position on the one hand and safely released into the released position on the other.

This objective is achieved by the invention as a result of the features set out in claim 1. The surprising advantage obtained by the features set out in the characterising part of claim 1 resides in the fact that the arrangement of the orifice extending through the wall of the holder container or end wall of the holder container in the region of the longitudinal median axis, combined with the two diametrically opposed abutment elements and the design of the slide in conjunction with the orifice and the retaining element and releasing element forming the retaining device in the orifice, offer a very simple retaining device consisting of only the slide and the holder body or holder container in a single piece. As a result of this seemingly very simple solution, when the slide is in the locked position, the insert element or needle assembly is retained in a fixed position relative to the holder body or holder container, in which the receiving device with the insert element or needle assembly retained therein is perfectly easy to use. Once it has been used for the intended purpose, it is a very simple operation for the user of a holder device of this type to displace the slide with the insert element or needle assembly from its locked position into the released position, from which, by displacing the slide transversely to the holder container, the insert element or needle assembly can be moved by the releasing element into a position in which it can be detached from the holder container or slide and the used needle assembly moved into a position in which the needle tip remote from the holder container is pointing in the direction towards the ground or floor and can be readily removed in a one-handed operation due to force of gravity or gravitational pull without any further contact. Advantageously, the receiving device is of a very simple and above all inexpensive design, consisting of a holder body or container and the single-piece slide for holding the needle assembly, which are inexpensive in terms of manufacturing and assembly costs and distinctive due to the simple structure, operating safety and one-handed operation.

- 3 -

Another embodiment defined in claim 2 is also of advantage. This design of holder body provides a holder container that is simple to use for taking samples without the other needle tip in the region of the interior being able to cause injury to a user. The design of the holder container also makes it easier to manipulate.

Another embodiment defined in claim 3 is of advantage because the one-piece design of the slide obviates the need for the complex manufacturing processes that would be needed if a plurality of components were required, whilst at the same time simplifying and reducing the cost of assembling the one-piece design on the holder container.

The embodiment described in claim 4 guarantees that the slide can be accurately transversely displaced in a direction parallel with the end wall, thereby facilitating one-handed operation.

With another embodiment defined in claim 5 or 6, the slide is more accurately guided relative to the holder container and the displacement path can also be restricted.

With the embodiments defined in claims 7 to 10, the insert element or needle assembly can be accurately supported on one of the support faces of the supporting elements without the needle assembly shifting relative to the holder body or holder container.

The embodiments defined in claims 11 to 16 are of advantage because, when the retaining element and releasing element are arranged in differing positions relative to one another, they enable the retaining force of the insert element or needle assembly on the receiving device, on the one hand, and the displacement force which needs to be applied, on the other, to be set. The greater the selected distance between the retaining element and the releasing element in the direction of the orifice, the greater the length of the circle segments used to retain the insert element or needle assembly will be. However, the insertion cross section between the retaining element and the releasing element is simultaneously reduced, which increases the displacement force.

Another possible embodiment is that described in claim 17, which enables the retaining element or releasing element to be exactly positioned relative to the orifice through the wall or end wall.

- 4 -

During the process of displacing the slide relative to the holder container, the embodiments described in claims 18 to 20 permit an additional ejection or releasing force, starting from the supporting faces extending at an incline to the top face, which assists the releasing action of the insert element or needle assembly from the receiving device in a sort of "kick-off" effect. Because of this rapid release process in the form of an ejection action, when the needle is directed downwards, even if it is in an inclined position, the releasing action is effected rapidly so that the part of the needle located in the interior of the holder container is reliably prevented from brushing against any of the components of the holding device even though the needle assembly might be in an inclined position relative to the holder container. The entire holding device is therefore also safely protected against contamination.

Other advantageous embodiments of the holding device are outlined in claims 21 to 49, the advantages of which can be found in the detailed description.

Finally, other advantageous embodiments are described in claims 50 to 54, whereby the individual lands are prevented from widening in the locked position, thereby producing a stable and above all safe retaining action for the needle assembly in the usage position. This also produces a strengthening effect or stiffening effect of the lands, which is nevertheless immediately relaxed on release from the locked position, easily and safely displacing the needle assembly into the released position.

The invention will be described in more detail below with reference to the examples of embodiments illustrated in the drawings.

Of these:

- Fig. 1 is a simplified perspective diagram of a holding device as proposed by the invention;
- Fig. 2 is a plan view of the holder container of the holding device illustrated in Fig. 1 with the slide removed;
- Fig. 3 is a view of the holder container of the holding device illustrated in Fig. 2 along the lines III-III of Fig. 2;

- 5 -

- Fig. 4 is a simplified, perspective diagram of the slide of the holding device illustrated in Fig. 1;
- Fig. 5 is a plan view of the slide of the holding device illustrated in Fig. 4;
- Fig. 6 is a plan view on an enlarged scale of a part region of the slide illustrated in Figs. 4 and 5 in the region of the retaining device;
- Fig. 7 shows a part region of the holding device with the insert element inserted, as illustrated in Figs. 1 to 6, in the region of the retaining device in the locked position and on an enlarged scale;
- Fig. 8 shows the holding device of Fig. 7 in the released position for the insert element;
- Fig. 9 is a simplified diagram in plan view of another slide for the holding device;
- Fig. 10 shows the slide of Fig. 9 from a side view;
- Fig. 11 is a plan view of the holder container of the holding device for the slide illustrated in Figs. 9 and 10, with the slide removed;
- Fig. 12 is a plan view of the holding device with the slide illustrated in Figs. 9 to 11;
- Fig. 13 is a plan view of another embodiment of a holding device with slide;
- Fig. 14 is a simplified diagram in plan view of the slide for the holding device illustrated in Fig. 13;
- Fig. 15 is a side view of the slide illustrated in Figs. 13 and 14 along lines XV-XV of Fig. 14;
- Fig. 16 is a simplified diagram in plan view of another embodiment of the holding device;
- Fig. 17 is a side view of the holding device illustrated in Fig. 16;

- 6 -

Fig. 18 is a simplified diagram in side view of another embodiment of the holding device;

Fig. 19 is a plan view of the holding device illustrated in Fig. 18;

Fig. 20 is a side view of the holding device illustrated in Figs. 18 and 19 in the released position for the insert element;

Fig. 21 is a simplified diagram in plan view of another embodiment of the holding device;

Fig. 22 shows a part region of the holding device illustrated in Fig. 21 with a simplified diagram of the insert element in the region of the retaining device, in the locked position;

Fig. 23 shows the part region of the holding device illustrated in Fig. 22 in the released position for the insert element;

Fig. 24 is a plan view of another embodiment of a holding device with slide;

Fig. 25 shows the part region of the holding device with slide, in a side view along lines XXV-XXV of Fig. 24.

Firstly, it should be pointed out that the same parts described in the different embodiments are denoted by the same reference numbers and the same component names and the disclosures made throughout the description can be transposed in terms of meaning to same parts bearing the same reference numbers or same component names. Furthermore, the positions chosen for the purposes of the description, such as top, bottom, side, etc., relate to the drawing specifically being described but can be transposed in terms of meaning to a new position when another position is being described. Individual features or combinations of features from the different embodiments illustrated and described may be construed as independent inventive solutions or solutions proposed by the invention in their own right.

Figs. 1 to 8 illustrate a holding device 1 for an insert element, in particular for a needle assembly 2 for taking samples of body fluids, pieces of tissue or tissue cultures, comprising a holder body, e.g. a

- 7 -

holder container 3, and a retaining device 4, an operating device 5 and optionally a guide device 6. The holder body or holder container 3 may be of any three-dimensional shape. However, the holding device 1 may be used for releasably holding the insert element as required, in which case it may be used for administering medicaments, solutions, mixtures, etc., instead of taking samples of body fluids or similar.

The holder container 3 of the holding device 1 has end regions 7, 8 spaced at a distance apart, between which a container casing 9 extends. The first end region 7 of the holder container 3 is open and the other end region 8 is closed off by an end wall 10. As a result of the layout and design of the container casing 9 in conjunction with the end wall 10, they enclose an interior chamber 11 having a longitudinal median axis 12 extending between the two end regions 7 and 8 more or less at the centre of the container casing 9. Facing into the interior chamber 11 of the holder container 3 is an internal face 13 of the container casing 9 and an internal face 14 of the end wall 10. Furthermore, on the side remote from the interior chamber 11, the holder container 3 has, in the region of the container casing 9 respectively, an external face 15 and, in the region of the end wall 10, another external face 16.

As may be seen more clearly from Figs. 2 and 3, the end wall 10 of the holder container 3 has an orifice 17 extending through the end wall 10 approximately in the region of the longitudinal median axis 12. This orifice 17 is provided as a means of receiving the needle assembly 2, which is held in place on the holding device 1 by the retaining device 4 and a part of a cannula 18, which is not illustrated here, projecting into the interior chamber 11 of the holder container 3. The orifice 17 may be of any shape in cross section, depending on the application. The needle assembly 2 in the embodiment illustrated as an example here is of a design whereby the cannula 18 is provided in the form of a single-piece hollow needle with tips at both end faces. Since the needle assembly 2 may be of any known design, it will not be described in further detail. Across the longitudinal path in the direction of the longitudinal median axis 12 and more or less in the central region thereof, the needle assembly 2 is also provided with a positioning member 19 so that it can be releasably retained on the holding device 1 as required by means of the retaining device 4. The retaining device 4 and the way in which it operates will be described in detail below.

It would also be possible for the holder body of the holding device 1 to have at least one wall in which the orifice 17 and the guide device 6 may be provided. Instead of the needle assembly 2, it

- 8 -

would also be possible to retain an insert element of any other type.

Moreover, if necessary, a cover device in the form of a pipe compression valve could additionally be provided at the end of the cannula 18 facing the interior chamber 11 of the holder container 3.

To facilitate handling or operation of the holding device 1, a hand grip is formed onto the container casing 9 in the area of the open end region 7, although this is illustrated in a simplified diagrammatic form only. Like end wall 10, the hand grip is preferably aligned more or less in a plane 20 running perpendicular to the longitudinal median axis 12.

The holding device 1 described and illustrated here, with the needle assembly 2 inserted therein, is used to receive a blood sampling tube, not illustrated in detail, in the region of the interior chamber 11 enclosed by the container casing 9. This being the case, the blood sampling tube may be of the design described in WO 89/09735, for example, consisting of a cylindrical housing open at one end, which is closed at the open end face by means of a gas-tight closure device. The closure device itself consists of a cap engaged over the housing and a stopper closing off the interior of the blood sampling tube. In the unused state, the interior of the blood sampling tube closed off by this stopper can be evacuated to produce a vacuum of between 100 mbar and 800 mbar, for example.

The external face 16 in the region of the end wall 10 forms a plane 20 aligned substantially perpendicular to the longitudinal median axis 12, parts of the guide device 6 in the form of guide elements 21 being disposed in the region of the face 16. Running through the centre of the longitudinal median axis 12 is a schematically indicated dividing plane 22, which, in the embodiment illustrated as an example here, could also be described as a plane of symmetry. In view of the parallel alignment with the longitudinal median axis 12, this dividing plane 22 is disposed at a right angle, in other words perpendicular, to the plane 20. The two guide elements 21 of the guide device 6 mentioned above are disposed on either side of the dividing plane 22 on the external face 16 of the end wall 10 and project out on the side remote from the interior chamber 11. As a result of this symmetrical arrangement of the two guide elements 21 relative to the dividing plane 22, the two guide elements 21 could also be described as being in a diametrically opposed arrangement.

As may be seen more readily from Fig. 3, each of the guide elements 21 has a substantially L-shaped

cross section, designed as a profiled section 23, with a respective leg 24, 25 facing a the end wall 10 of the holder container 3 and joined thereto. At the end remote from the end wall 10, the profiled sections 23 forming the guide elements 21 have other legs 26, 27 or shoulders or projections, directed facing one another in the direction of the dividing plane 22 and arranged at a distance from the external face 16 of the end wall 10. How the guide elements 21 co-operate with the operating device 5 will be described in detail farther on with reference to one of the other drawings. In the region of the legs 24 to 27 it would also be possible to provide respective guide surfaces 28 to 33 on the side facing the end wall 10. Depending on how the operating device 5 is designed to co-operate with the guide device 6, different guide surfaces 28 to 33 may be used for the guiding function. In the embodiment illustrated as an example here, the guide surfaces 28, 30 and 31 and 33 run parallel with the dividing plane 22 and the guide surfaces 29, 32 parallel with the plane 20. Clearly, however, the individual guide surfaces 28 to 33 could also be angled relative to the plane 20 or dividing plane 22. The important point, however, is that a distance between respectively facing guide surfaces 28, 31 or 30, 33 is selected so as to be constant across the longitudinal extension thereof.

The guide surfaces 28, 29 and 31, 32 in the embodiment illustrated as an example here, which are angled, in particular perpendicular to one another, form groove-shaped guide passages in conjunction with the face 16 of the end wall 10 on either side of the dividing plane 22. The other guide surfaces 30, 33 may also be angled, in particular perpendicular to the guide surfaces 29, 32. The purpose of these guide passages of the guide elements 21 bounded by the legs 24 to 27 is to guide the operating device 5 parallel with the plane 20 and if necessary so that they can be adjusted relative to and on the holder container 3 in the direction of the dividing plane 22.

As may also be seen from Figs. 2 and 3, on the side remote from the interior chamber 11 in the region of the end wall 10, one and preferably several supporting members 34, 35 are provided, which, in the embodiment illustrated as an example here, are aligned parallel with the guide surfaces 28, 30 and 31, 33 in their longitudinal extension. Furthermore, the supporting members 34, 35 are arranged one after the other in the region of the dividing plane 22 and on either side of the orifice 17. These supporting members 34, 35 also project beyond the face 16 of the end wall 10 on the side remote from the interior chamber 11, ends 36, 37, which face away from one another, of the supporting members 34, 35 being spaced apart from one another by a distance 38. Transversely to the longitudinal extension in a direction perpendicular to the dividing plane 22, the supporting members 34, 35 are of a

- 10 -

thickness 39, which is preferably smaller than an internal clearance dimension 40 of the orifice 17 in the end wall 10. As described above, the two supporting members 34, 35 are arranged in the dividing plane 22 and the supporting members 34, 35 could also be described as being disposed diametrically one after the other as viewed in the direction of the dividing plane 22. In the embodiment illustrated as an example here, two supporting members 34, 35 are illustrated and described but it would also be possible to provide only a single supporting member 34 or 35 with the orifice 17 extending through it. Irrespective of this however, it would also be possible to provide several of these supporting members 34, 35 in the region of the face 16 of the end wall 10.

Ends 41, 42 of the two supporting members 34, 35 which face one another respectively form support surfaces 43, 44, which are preferably disposed in the end wall 10 of the holder container 3 immediately adjacent to the orifice 17. These support surfaces 43, 44 may be flat and parallel with one another or bent relative to the longitudinal median axis 12. Alternatively, the support surfaces 43, 44 facing one another may also be concave or partially cylindrical in shape, in which case a central point of curvature of these part surfaces may run through the longitudinal median axis 12. The shape of cross section selected for the orifice 17 is variable, depending on the application, and may be circular, elliptical, square, rectangular or alternatively polygonal, for example. In the embodiment illustrated as an example here, a circular design has been chosen, although it would also be possible for the orifice 17 to be of a square design. As also illustrated, the two support surfaces 43, 44 are arranged and aligned substantially flush with the faces bounding the orifice 17. However, these support surfaces 43, 44 could also be spaced at a distance from the faces bounding the orifice 17. It is of advantage if the support surfaces 43, 44 are disposed parallel with one another and parallel with the longitudinal median axis 12. The way in which the supporting members 34, 35 and their support surfaces 43, 44 co-operate with the operating device 5 and the needle assembly 2 will also be described farther on with reference to other drawings.

Figs. 4 to 6 provide a detailed illustration of the operating device 5 for the holding device 1, being provided in the form of a slide 45 in the embodiment illustrated as an example here. This slide 45 is substantially plate-shaped and when positioned on the holder container 3 has a bearing face 46 directed towards the end wall 10 of the holder container 3 and a top face 47 spaced at a distance therefrom. Extending between the bearing face 46 and the top face 47 are side faces 48 to 51, which determine the three-dimensional shape of the slide 45.

- 11 -

Disposed substantially centrally to the two side faces 48, 49 is another dividing plane 52, schematically illustrated in Fig. 5, which, in the embodiment illustrated as an example here, is also substantially a plane of symmetry and is disposed in the direction of the longitudinal extension of the slide 45. In the region of this dividing plane 52, the slide 45 has a preferably slot-shaped orifice 53 extending between the bearing face 46 and the top face 47. In the direction of the dividing plane 52 or in the longitudinal extension of the slide 45, this orifice 53 has a length 54 and, in a perpendicular direction, a width 55.

Moreover, the retaining device 4 for the needle assembly 2 described above is provided in the region of the longitudinal extension of the orifice 53 and is provided in the form of a retaining element 56 and a releasing element 57 in this embodiment.

In this particular embodiment, the length 54 of the orifice 53 is longer than its width 55. Furthermore, the length 54 of the orifice 53 is longer in its longitudinal extension than the largest distance 38 between the remotely facing ends 36, 37 of the two supporting members 34, 35. As a result of these differences in length between the length 54 of the orifice 53 and the distance 38, the slide 45 can be displaced in the plane 20 in the longitudinal direction of the orifice 53 in co-operation with the supporting members 34, 35. Moreover, the width 55 of the orifice 53 is at least the same as but preferably greater than the thickness 39 of the two supporting members 34, 35, which, if tolerances are selected accordingly, prevents any rotating movement of the slide 45 relative to the holder container 3.

In order to guide the relative displacement of the slide 45 with regard to the holder container 3, additional guide members 58 may also be provided in the region of the side faces 48, 49 which co-operate with the guide elements 21 of the holder container 3 and form the guide device 6. The two guide elements 58 on the slide 45 in the embodiment illustrated here are provided in the form of indentations 59, 60 on either side of the slide 45 in the transition region between the top face 47 and the side faces 48 and 49, which are preferably disposed parallel with one another, each of the indentations 59, 60 being bounded by slide faces 61 to 64 which are preferably disposed in the slide 45 parallel with the longitudinal extension of the orifice 53. Accordingly, a length 65 of the individual slide faces 61 to 64 in the slide 45 corresponds to at least one longitudinal dimension 66 of the guide elements 21 on the holder container 3 plus a central distance 67 between the centre of the retaining element 56 and the centre of the releasing element 57.

- 12 -

In the embodiment illustrated as an example here, the retaining element 56 in the slide 45 is provided in the form of a bore 68 provided with an internal thread 69, a clearance internal dimension 70 being greater than the width 55 of the orifice 53. The releasing element 57 in this embodiment is preferably provided in the form of a recess 71 extending into the slide 45, the internal clearance width 72 of which is greater than the clearance internal dimension 70 of the retaining element 56. It is also of advantage if the retaining element 56 forming the bore 68 and the releasing element 57 forming the recess 71 are aligned parallel with one another and perpendicular to the bearing face 46 and top face 47 of the slide 45 since this will enable the needle assembly to be aligned parallel with the longitudinal median axis 12 of the holding device 1.

As may be seen more clearly from Figs. 5 and 6, the retaining element 56 forming the bore 68 and the releasing element 57 forming the recess 71 are arranged in the slide immediately adjacent to one another in the direction of the length 54 of the orifice 53 and it is of advantage if the bore 68 and the recess 71 overlap in the direction of the length 65 of the orifice 53. In order to produce this overlap in the region of the orifice 53, the mid-distance 67 between the bore 68 and the recess 71 may be smaller than half the sum of the clearance dimension 70 of the bore 68 plus the internal clearance width 72 of the recess 71. The greater the mid-distance 67 between the bore 68 and the recess 71, the greater the displacement path will be between the locked position and the released position and longer circle segments will be formed respectively in the region of the bore 68 and the recess 71, so that, because of the longer circle segments in the region of the bore, a higher retaining force can be produced for the insert element or needle assembly 2. Accordingly, this produces a smaller end-to-end width between the bore 68 and the recess 71, thereby increasing the displacement force.

As may be seen more clearly from Figs. 4 and 5, at least one respective support surface 73, 74 is provided on the top face 47 of the slide 45 on either side of the dividing plane 52 or on either side of the orifice 53, designed so that the length extends at an incline relative to the top face 47. A start 75 of the support surfaces 73, 74 in the region of the recess 71 or releasing element 57 is disposed in the slide 45 and an end 76 thereof is disposed on the side remote from the retaining element 56 or bore 68. The start 75 of the support surfaces 73, 74 is arranged extending substantially flush with the top face 47 and the end 76 thereof projects beyond the top face 47. The support surfaces 73, 74 are inclined at an angle to the top face 47 and subtend between them an angle of between 5° and 30°.

- 13 -

In the direction of the longitudinal extension, the orifice 53 has end sections 77, 78 spaced at a distance apart, bounding the length 54 of the orifice 53 in its longitudinal extension. How the slide 45 co-operates with the holder container 3, in particular the retaining device 4 with the supporting members 34, 35 and the way in which the guide device 6 works will be described in more detail with reference to other drawings.

Figs. 7 and 8 provide simplified, schematic diagrams on a larger scale illustrating the holding device 1 with the needle assembly 2 retained thereon, the holder container 3 as well as the operating device 5, Fig. 7 showing the position in which the needle assembly 2 is locked in the retaining device 4, namely the retaining element 56.

As described earlier, the positioning element 19 is retained against the cannula 18 and may be of any design. In the embodiment illustrated as an example here, in the region of the retaining element 56 provided in the form of the bore 68 with the thread 69, the positioning element 19 has a complementary continuation 79, the external surface of which is provided with an external thread 80. This external thread 80 is designed to co-operate with the internal thread 69 or its thread pitches in the bore 68, which is designed as a screw thread or internal thread, so that it can be screwed into the slide 45. Directly adjoining the continuation 79 on the side remote from the holder container 3, the positioning element 19 also has a shoulder 81 projecting in a radial direction from the continuation 79, which restricts the screwing depth of the positioning element 19 with the cannula 18 retained thereon and bears substantially against the top face 47 of the slide 45 in the screwed-in state.

When the holding device 1 is in the position illustrated in Fig. 7, the centre of the retaining element 56 is disposed substantially centrally relative to the longitudinal median axis 12 of the holder container 3. As described above, in the region of the longitudinal median axis 12, the orifice 17 is disposed in the end wall 10 of the holder container 3 and the two supporting members 34, 35 are arranged on the end wall 10 of the holder container 3 in the immediate vicinity of this orifice 17. The two ends 36, 37 are spaced apart from one another by the distance 38 in the direction of the dividing plane 22 so that the orifice 35 is of a longer length 54 than this distance 38 in the same direction. Because of the centred or coincidental arrangement of the bore 68 of the retaining element 56 in the slide 45 and the longitudinal median axis 12 or orifice 17, the orifice 53 in the slide is designed so that the first end portion 77 of the orifice 53 is disposed substantially abutting with the end 37 of the

supporting member 35 in this position.

The other end portion 78 of the orifice 53 is spaced apart from the other end 36 of the supporting element 34 by a distance 82. This distance 82 may be dimensioned so that when the slide 45 is displaced in the direction of arrow 83, the slide 45 is moved starting from the locked position illustrated in Fig. 7 into the released position illustrated in Fig. 8 and the positioning element 19, and with it the needle assembly 2, moves from the retaining element 56 in the slide 45 into the region of the releasing element 57 formed by the recess 71 in the slide 45 without any transverse displacement of the needle assembly 2 relative to the holder container 3 to speak of. The needle assembly 2 is prevented from shifting transversely in the direction of the sliding movement of the slide 45 by the abutment of the positioning element 19 against one of the support surfaces 43, 44. As a result of the differences in dimensions between the retaining element 56 and the releasing element 57, as described above, the needle assembly 2, in particular the positioning element 19, is safely released from the slide 45 in a simple manner due to the transverse displacement of the slide 45 relative to the holder container 3 and optionally in co-operation with the guide device 6.

Fig. 8 illustrates the slide 45 in the position in which it is released from the holder container 3, the other end portion 78 moving to bear more or less on the other end 36 of the supporting member 34 in this position, whilst the first end portion 77 of the orifice 53 is spaced at a distance back from the first end 37 of the supporting member 35.

As may be seen by referring to Figs. 4 to 8 together, as the slide 45 is displaced relative to the holder container 3 in the direction of arrow 83, the shoulder 81 of the positioning element 19 is disposed in the region of the start 75 of the support surfaces 73, 74 before the displacement process and, during the displacement process from the locked position to the released position, the support surfaces 73, 74 running at an angle to the top face 47 cause an additional releasing effect of the needle assembly 2, in particular the continuation 79, from the retaining element 56, which in turn causes the entire needle assembly 2 to move in the direction of a schematically shown arrow 84 in the direction of the slide 45 away from the holder container 3.

The additional displacement or releasing force in the direction of arrow 84 or in the direction away from the holder container 3, further assists the release of the needle assembly 2 by the releasing ele-

- 15 -

ment 57 and an assisted releasing action of the needle assembly 2 is advantageously produced when the needle tip of the cannula 18 is pointing in a direction towards the ground, this action being enhanced by the force of gravity.

As described above, the two supporting members 34, 35 and their support surfaces 43, 44 on either side of the orifice 17 provide a means of preventing any relative displacement of the needle assembly 2, in particular the positioning element 19, relative to the holder container 3 as the slide 45 slides in the direction of arrow 83 and as the slide 45 is displaced relative to the holder container 3 they prevent any relative shift of the needle assembly 2 relative thereto. As a result, the slide 45 can now be moved from the locked position into the released position without the needle assembly 2 being displaced or shifted relative to the holder container 3.

Figures 9 to 12 are simplified, schematic diagrams illustrating another embodiment of the holding device 1 which may be construed as an independent embodiment, the same reference numbers as those used in Figs. 1 to 8 being used to denote same components. For the sake of simplicity and in order to avoid unnecessary repetition, reference should be made to the description of the drawings given above for information relating to the design and layout of the individual components or component groups.

In this embodiment, the holding device 1 consists of the holder container 3 and the operating device 5, which is again provided in the form of a slide 45. A guide device 6 of the type described above is arranged between the holder container 3 and the operating device 5, enabling a relative displacement of the operating device 5, namely the slide 45, relative to the holder container 3 in a direction perpendicular to the longitudinal median axis 12.

The longitudinal median axis 12 extends centrally to the container casing 9 and, as before, an orifice 17 is provided in the end wall 10 of the holder container 3. In the embodiment illustrated as an example here, the orifice 17 has a square cross section, the corner regions of which are rounded in the transition area. On either side of the orifice 17, also in the region of the dividing plane 22, the two supporting members 34, 35 are provided on the end wall 10 of the holder container 3 and project from the end wall 10 or its face 16 in the direction of the side remote from the interior.

- 16 -

The supporting members 34, 35 co-operate with the needle assembly 2, not illustrated here, more particularly the positioning element 19 thereof, in the same way as described in detail above with reference to the embodiment illustrated in Figs. 1 to 8.

The slide 45 in this embodiment is again of a symmetrical design relative to the dividing plane 52 running in the longitudinal direction thereof, the orifice 53 being provided in the slide 45 in this dividing plane 52, running through it in the direction of the longitudinal median axis 12. The retaining device 4 is again disposed in the orifice 53, one part of the orifice 53 forming the retaining element 56 and another part the releasing element 57. The retaining element 56 in the slide 45 is provided in the form of the bore 68 with the internal thread 69 and has the clearance internal dimension 70. Immediately adjacent to the retaining element 56 is the releasing element 57, which in this case is provided in the form of a preferably circular recess 71 through the slide, the internal clearance width 72 being of the same size as the clearance internal dimension 70 of the retaining element 56.

In this embodiment, as illustrated, the two support surfaces 73, 74 running parallel with the dividing plane 52 are arranged in the immediate vicinity of the releasing element 57 and are spaced apart from one another by a distance 85 in the direction perpendicular to the dividing plane 52. These two support surfaces 73, 74 again run at an angle to the top face 47 of the slide 45.

The distance 85 between the two support surfaces 73, 74 is selected so that it is smaller than an external dimension 86 - see Fig. 8 - of the shoulder 81 of the positioning element 19. As a result of these differences in dimension, the side of the shoulder 81 facing the top face 47 is guaranteed to bear, at least in certain regions on either side of the releasing element 57, against the two support surfaces 73, 74, as a result of which the releasing action of the needle assembly 2, in particular of the positioning element 19, described above is assisted as the slide 45 is displaced relative to the holder container 3 in the same way as described above with reference to Figs. 1 to 8.

Also with this embodiment of the holding device 1, as illustrated, a catch device 87 which may be displaced as required is provided between the holder container 3 and the operating device 5, which checks the two positions of the slide 45 relative to the holder container 3 in the locked position and/or in the released position as required. This catch device 87 comprises first catch elements 88, 89 which, in the embodiment illustrated as an example here, are provided in the form of recesses in the

- 17 -

face 16 of the end wall 10. These two catch elements 88, 89 are symmetrical with one another relative to the dividing plane 22, spaced at a distance 90 apart from one another. As may be seen from the diagram of Fig. 11, these catch elements 88, 89 are provided as recessed, spherical depressions disposed between the orifice 17 and the guide elements 21 of the guide device 6. However, it would also be possible to arrange these catch elements 88, 89 in a different position or to provide them with a three-dimensional shape other than that described and illustrated here.

As may be seen more clearly from Fig. 9, and as explained in detail with reference to Figs. 4 to 6, the centre of the retaining element 56 is spaced at a mid-distance 67 from the centre of the releasing element 57.

Other catch elements 91 are provided on the bearing face 46 of the slide 45 in a complementing layout and in this embodiment are arranged in the half mid-distance 67 between the retaining element 56 and the releasing element 57. The two catch elements 91 are arranged transversely to the dividing plane 52 at a distance 92 apart from one another, which is the same as the distance 90 in the same direction between the individual catch elements 88, 89.

In order to position and align the retaining element 56 or the releasing element 57 exactly relative to the longitudinal median axis 12 or the orifice 17, the catch elements are spaced apart from one another in a direction perpendicular to the transverse plane or parallel with the dividing plane 22, in the region of the end wall 10 in a transverse plane perpendicular to the dividing plane 22 and parallel with the longitudinal median axis 12, by a longitudinal distance 93 corresponding in dimension to the mid-distance 67 between the retaining element 56 and the releasing element 57.

As a result of the selected dimensions and layout of the individual catch elements 88, 89, 91 relative to one another, the retaining element 56 is disposed in a substantially centred alignment on the orifice 17 when the catch elements 91 of the slide 45 are engaged with the catch elements 88 on the end wall 10 of the holder container 3. When the slide 45 is displaced relative to the holder container 3, the catch elements 91 are released from the first catch elements 88 and engage with the other complementary catch elements 89 after a sliding motion in the direction of the dividing plane 22 or in the direction perpendicular to the transverse plane, so that the releasing element 57 is in an alignment substantially centred on the longitudinal median axis 12 or the orifice 17. As a result of this dis-

- 18 -

placement and the different engaging actions of the catch elements 91 on the slide 45 with the catch elements 88, 89 spaced apart from one another, a certain checking action is imparted between the catch elements in the different positions, as a result of which the slide 45 is held or retained in the respective position relative to the holder container 3.

As shown by the dotted-dashed line shown in the simplified diagram of Fig. 12, however, it would also be possible to provide at least a first catch element 88 on the face 16 of the end wall 10 of the holder container 3 in the region peripheral to the container casing 9 and, on the bearing face 46 of the slide 45 facing it, at least one other catch element 91 so that when the two catch elements 88, 91 are in the engaged position, the retaining element 56 is disposed in a centred or coinciding alignment with the orifice 17 or the longitudinal median axis 12. In the released position, by contrast, the two catch elements 88, 91 are disengaged and the catch elements 91 project from the external face 15 of the container casing 9 on the side remote from the interior chamber 11. As a result of this arrangement, the two catch elements 88, 91 are only engaged in the locked position.

The design and layout of the orifice 53 relative to the supporting members 34, 35 may be as described above in relation to Figs. 1 to 8. In addition, it is also of advantage if a longitudinal extension of the slide 45 in the direction of the orifice 53 corresponds approximately to an external dimension of the holder container 3 in the region of the closed end region 8 thereof. Accordingly, during injection for drawing off body fluids or administering medicaments or solutions, a relatively flat angle is obtained between the body part and the holding device 1. In addition, the needle assembly 2 is prevented from inadvertently unlatching itself from the holder container 3 as would occur in the event of any undesirable displacement of the slide 45.

Clearly, however, it would be possible to set the displacement path of the slide 45 relative to the holder container 3 - which corresponds to at least the mid-distance 67 between the retaining element 56 and the releasing element 57 - solely by means of the individual catch elements 88, 89 or 91 engaging in one another. Furthermore, it would also be possible to set or restrict the relative displacement path between the slide 45 and the holder container 3 by selecting the length 54 of the orifice 53 and the distance 38 between the ends 36, 37 of the supporting members 34, 35. Alternatively, this relative displacement could also be determined by means of the guide elements 21 or 58 engaging with one another as described above with reference to Figs. 1 to 8. It would also be possible to use

any combination of the embodiments described above and more than one means for restricting the displacement path.

Figs. 13 to 15 illustrate another embodiment of the holding device 1 which may optionally be construed as an independent embodiment, the same reference numbers being used to denote parts common to those illustrated in Figs. 1 to 12. In order to avoid unnecessary repetition, reference should be made to the description relating to Figs. 1 to 12 above for a detailed description of the individual components or groups of components.

The holding device 1 again consists of the holder container 3 and the operating device 5, between which the guide device 6 is arranged. The design and layout of the guide elements 21 and 58 forming the guide device may be as described with reference to Figs. 1 to 15. Provided in the dividing plane 22 on the end wall 10 of the holder container 3 are the supporting members 34, 35, used to support the positioning element 19 - see Fig. 1 - as the operating device 5, namely the slide 45, is displaced relative to the holder container 3. The orifice 17 in the end wall 10 is again centred on the longitudinal median axis 12 of the holder container 3. Clearly, as an alternative, the orifice 17 and the two supporting members 34, 35 could be arranged off-centre or eccentrically relative to the holder container 3 or longitudinal median axis 12 if there were no need for the needle assembly 2 to be centrally aligned on the container casing 9, which in this case is circular in shape. This arrangement is, of course, freely selectable and will depend on the application or usage to which the holding device 1 will be put. Care should be taken to adapt the layout of the individual components to produce the required degree of displacement.

Fig. 13 illustrates the locked position between the slide 45 and the holder container 3, in which the retaining element 56 is substantially centrally aligned with the longitudinal median axis 12 or orifice 17. In this initial position or locked position, the insert element or needle assembly 2 may be inserted and retained in the retaining element 56. The threaded arrangement between the positioning element 19 and the retaining element 56 provides a simple screw-fitting. Instead of the threaded arrangement, however, it would also be possible to provide an appropriate snap-fit connection or catch connection.

Fig. 13 also provides a simplified illustration of the design of the catch device 87 with catch elements 88 and 91 which can be engaged with one another, at least a first catch element 88 being provided on

- 20 -

at least one of the guide faces of a guide element 21 and at least another catch element 91 being provided on at least a slide face of the indentation 59, 60 in the slide 45 facing this guide face. The layout of the two catch elements 88, 91 relative to one another may be selected so that when the catch elements 88, 91 are in the latched position, the retaining element 56 is fixed in a central or coinciding alignment with the orifice 17 or longitudinal median axis 12. Irrespective of this, however, any combination of the catch elements 88, 89, 91 described above may be used. Co-operating catch elements 88, 89, 91 could be provided between the external face 16 of the wall or end wall 10 and the bearing face 46 of the slide 45 and other catch elements 88, 89, 91 between oppositely facing guide faces 28 to 33 of the guide element 21 and slide faces 61 to 64 of the indentations 59, 60 in the slide 45. The number and alignment of the individual catch elements 88, 89, 91 relative to one another can be freely selected.

In this initial position or locked position, the end portion 77 of the slide 45 is aligned substantially abutting with the end 37 of the supporting member 35 and the retaining element 56 is simultaneously also centrally aligned on the longitudinal median axis 12 or orifice 17. In order to prevent any undesirable sliding movement or displacement of the slide 45 relative to the holder container 3, the slide 45 in this embodiment is provided with a separate spring element 94, which in this case bears against the end 36 of the supporting member 34.

In order to accommodate this spring element 94, the orifice 53 is larger in cross section on the side of the releasing element 57 remote from the retaining element 56, the bent spring element 94 projecting into this orifice. The layout and design of the spring element 94 inside the orifice 53 is not restricted to the three-dimensional shape illustrated here and may be of any three-dimensional shape that will produce sufficient force to hold the slide 45 in its initial position or locked position relative to the holder container 3. As a result of the spring force applied by the spring element 94 to the end 36 of the supporting member 34, the slide 45 applies a thrust force in the region of the end portion 77 in the direction of the end 37 of the supporting member 35.

When the slide 45 is displaced in the direction of arrow 83 relative to the holder container 3, a return force of the slide 45 in the direction of an arrow 95 is produced due to the deformation of the spring element 94, as a result of which the slide 45 is automatically returned to the initial or locked position, once the needle assembly 2 has been released. Accordingly, a very simple means is provided

- 21 -

whereby, in addition to the releasing action during which the needle assembly 2 or insert element is released from the holding device 1, the slide 45 is automatically returned to its position.

In order to set the requisite amount of displacement force which needs to be applied to the slide 45 in the direction of arrow 83, an orifice 96 is provided in the slide 45 of this embodiment on either side of the dividing plane 52 in the region of the orifice 53 between it and each of the side faces 48, 49 and also extends through the slide 45 in the direction of the orifice 53. In this embodiment, the orifices 96 extend in the longitudinal direction of the slide 45 substantially between the end portion 77 and the end of the releasing element 57 remote from this end portion 77. This allows the displacement force which needs to be applied in the direction of arrow 83 to be set since, as a result of the selection and size of the orifice 96, a respective land 97 is provided between the latter and the orifice 17 in the region of the dividing plane 52, which has a variable land thickness 98 in a direction perpendicular to the dividing plane, depending on the size of the orifice 96.

Because of the differing dimensions between the retaining element 56 and the releasing element 57, the two lands 97 are aligned at an angle to one another, the two subtending an acute angle which tapers starting from the releasing element 57 out towards the retaining element 56 or the two lands are disposed so that they run towards one another. As a result of the layout of the orifice 96, the land thickness 98 is substantially constant across the longitudinal extension of the lands 97. The slimmer the selected land thickness 98, the lower the amount of deformation force which has to be applied in order to deform the two lands 97 transversely to the dividing plane 52 or in the direction perpendicular thereto. Accordingly, the transition from the retaining element 56 to the releasing element 57 and the resultant release of the positioning element 19 from the retaining element 56 can be readily adjusted to one another, thereby setting the displacement to a predetermined degree, which means that it can be increased or reduced. As a result, the mid-distance 67 between the retaining element 56 and the releasing element 57 can be selected so as to be greater or longer - as described above in relation to Figs. 5 and 6 - providing a better hold for the insert element or positioning element 19 in the locked position.

As may be seen more clearly from Figs. 14 and 15, at least one recess 99 may also be provided in the region of the bearing face 46 of the slide 45 in order to reduce the size of the bearing face 46 on the face 16 of the end wall 10. This simultaneously also means that a certain amount of material can be

saved. However, in order to increase the full screwing-in depth if at least one recess 99 is provided in the region of the bearing face 46, the retaining element 56 may be designed to extend through the entire thickness of the slide 45. As a result, a bearing face 46 will also be provided in the region of the retaining element 56 to provide a bearing on the face 16 of the end wall 10, which, because of the bearing in this region, will provide a support against the end wall 10, reliably preventing any deformation during the screwing-in process. At the same time, as a result of the greater screwing-in depth across the full thickness of the slide 45, the needle assembly 2 will be more firmly and securely retained when the holding device 1 is used for its intended purpose.

Furthermore, the thickness of the land 97 and the requisite deformation force which will need to be applied accordingly for the displacement process can also be set by the choice of size of the recess 99 and the weakening of the slide 45 associated therewith. The greater the size of the recess 99, the slimmer the thickness of the lands 97 will be in the direction perpendicular to the top face 47.

As also illustrated in Fig. 15, on the bearing face 46 of the slide 45, the slide 45 is provided with a projection 100 extending out in the direction remote from the top face 47 and is designed to restrict the displacement path of the slide 45 at one end as it is displaced relative to the holder container 3. Accordingly, the projection 100 is designed and disposed on the bearing face 46 in the region of the side face 50 so that the latter is moved to bear on the external face 15 of the container casing 9 when the slide 45 is in the released position, thereby securely preventing any further displacement beyond the released position. When the slide 45 is in the locked position, the projection 100 is therefore spaced at a distance apart from the external face 15 of the container casing 9, this distance corresponding substantially to the mid-distance 67 between the retaining element 56 and the releasing element 57. This design is of advantage if a spring element 94 is provided inside the orifice 53 because it prevents any over-excessive deformation and hence any residual plastic deformation or breakage thereof. As a result, the requisite displacement path between the locked position and the released position corresponds more or less to the mid-distance 67 between the retaining element 56 and the releasing element 57. As described above, the slide or displacement path can also be restricted by guide elements 21 and 58 of the guide device 6 engaging in one another.

Figs. 16 and 17 illustrate another embodiment of another holding device 110, which may also be construed as an independent embodiment, in particular for a needle assembly 2, not illustrated, for

- 23 -

drawing samples from body fluids, pieces of tissue or tissue cultures and consists of a holder body, such as a holder container 111, for example, with a retaining device 112 and an operating device 113. To avoid unnecessary repetition, the same component names will be used for components common to the previously described Figs. 1 to 15.

The holder container 111 of the holding device 110 has end regions 114, 115 spaced at a distance apart, between which a container casing 116 extends. The first end region 114 is open and the other end region 115 is closed off, an end wall 117 being provided in the end region 115. As a result of the layout and design of the container casing 116 in conjunction with the end wall 117, they enclose an interior chamber 118, and a longitudinal median axis 119 extends between the two spaced end regions 114 and 115 more or less at the centre of the container casing 116 in this embodiment.

The operating device 113 in this embodiment is provided in the form of a substantially annular slide 120, the dimensions of which are such that an internal clearance dimension thereof substantially corresponds to an external dimension of the container casing 116. As a result, the slide 120 is retained so that it can be displaced as required along an external surface 121 of the container casing 116 in the direction of and along the longitudinal median axis 119. To do this, the container casing 116 must be substantially cylindrical or have the same dimensions relative to and in the direction of the longitudinal median axis 119. In the region of the end wall 117, at least one shoulder 122 disposed at least in certain regions around the periphery projects from the external surface 121 in the direction remote from the longitudinal median axis 119. The slide 120 is securely prevented from inadvertently working loose from the holder container 111 as a result of this shoulder 122.

In the region of the end wall 117, the holding device 110 also has a retaining device 112 for a needle assembly, not illustrated, and in the embodiment illustrated as an example here is provided in the form of a substantially annular retaining element 123. By preference, centred on the longitudinal median axis 119, the retaining element 123 has a bore 124 with a thread 125 in the form of a screw thread or internal thread. Accordingly, the needle assembly can be turned in the retaining element 123 in a screwing action where it is retained in the screwed-in position.

Fig. 17 illustrates the operating device 113, which is provided in the form of the slide 120, shown by solid lines in the locked position and broken lines in the released position for the needle assembly,

the released position merely indicating the possible position of the slide without showing any potential deformation that might also result from the displacement process. The locked position is the position in which the slide 120 is placed substantially abutting against the shoulder 122 in the region of the end wall 117. As indicated by double arrow 126, the slide 120 is displaced from the locked position into the released position indicated by broken lines, in which the needle assembly is released from the retaining device 112 and then returned to the locked position.

As may be seen by comparing Figs. 16 and 17, the end wall 117 is divided into several, in the case of this embodiment three, end wall parts 127 to 129, this division being made by slot-shaped orifices 130 in the end wall 117. In this embodiment, the slot-shaped orifices 130 are disposed offset from one another by an angle of approximately 120° in a plane perpendicular to the longitudinal median axis 119, although the size of this angle will depend on the number of end wall parts. If the end wall parts 127 to 129 and the angle between the slot-shaped orifices 130 are divided symmetrically, this angle can be calculated by dividing the full circle by the number of end wall parts. Accordingly, it would be possible to provide at least two but preferably more end wall parts. This slot-shaped orifice 130 also divides the retaining element 123 into a number of retaining elements 131 to 133 equal to the number of end wall parts 127 to 129, which therefore form circle segments with an internal thread.

The slot-shaped orifices 130 extend starting from the closed end region 115 or the end wall 117 in the direction of the open end region 114 along the longitudinal median axis 119 across a length 134. In this embodiment, as illustrated in Fig. 17, the slot-shaped orifice 130 in the container casing 116 is also designed so that it is conically tapered starting from the end wall 117 in the direction towards the end region 114, the length 134 of the orifice 130 being of any selected size which will depend on the degree to which the retaining elements 131 to 133 have to be opened relative to the longitudinal median axis 119.

As also illustrated, on the internal surface of the slide 120, positioning elements 135 are provided, these being the same in number and dividing angle as the slot-shaped orifices 130, which project from the internal surface of the slide 120 in the direction of the longitudinal median axis 119. The individual positioning elements 135 project or extend in such a way that they engage in the slot-shaped orifices 130 and, being also conical in shape during displacement in the direction of the dou-

- 25 -

ble arrow 126 from the locked position into the released position, the orifices 130 become wider. As a result, the individual end wall parts 127 to 129 with the retaining element parts 131 to 133 joined thereto and the walls parts 136 to 138 in the region of the container casing 116 between the orifices 130 arranged intermittently about the circumference are elastically deformed and displaced in the direction of the schematically indicated arrows 139. As a result of the widening caused by displacement of the slide 120 from the locked position into the released position, the retaining element 123 is centred relative to the longitudinal median axis 119 so that the individual retaining elements 131 to 133 with their internal thread are disengaged from the positioning element 19 of the needle assembly 2, not illustrated here.

When the holding device 110 is placed in a downwardly directed position in which the needle tip is pointing towards the floor and the natural weight or force of gravity act on the needle assembly, the needle assembly can be easily released from the holding device 110. Accordingly, the retained needle assembly can be released by simply pushing the slide 120 from the locked position into the released position and, once the slide 120 has returned to the locked position, a new needle assembly 2 can be screwed into the holding device 110.

Figures 18 and 19 illustrate another embodiment of the holding device 110, which may also be construed as an independent embodiment, in particular for a needle assembly 2, not illustrated, used for drawing samples from body fluids, pieces of tissue or tissue culture, consisting of a holder body, such as a holder container 111, for example, and a retaining device 112. To avoid unnecessary repetition, the same component names will be used in the description for components common to the previously described Figs. 1 to 17.

The holder container 111 has end regions 114, 115 spaced at a distance apart from one another, between which a container casing 116 extends. Again, the first end region 114 is open and the other end region 115 is closed off, the end wall 117 closing off the end region 115. A longitudinal median axis 119 extends substantially through the centre of the container casing 116 between the two spaced apart end regions 114, 115.

As described above, the holding device 110 has a retaining device 112 for a needle assembly 2, not illustrated, in the region of the end wall 117, which, in the embodiment illustrated as an example

- 26 -

here, is provided in the form of a substantially annular retaining element 123. The retaining element 123 has a bore 124, preferably centred on the longitudinal median axis 119, with an internal thread 125 in the form of a screw thread or internal thread. Accordingly, as before, the needle assembly 2 can be turned in the retaining element 123 in a screwing action and retained therein in the screwed-in position.

As may be seen from comparing Figs. 18 and 19, in the region of the end wall 117, parallel therewith or in a plane perpendicular to the longitudinal median axis 119, a hinge pin 140 is disposed or arranged on either side of the retaining element 123 extending between the external circumference of the holder container 111 and the external circumference of the retaining element 123. In this embodiment, the two hinge pins 140 are arranged concentrically or coaxially with one another, so that the two hinge pins 140 are aligned flush with one another in the longitudinal direction. The two hinge pins 140 directed towards one another form, in conjunction with the longitudinal median axis 119, a dividing plane 141 extending through the latter in which are also arranged slot-shaped apertures 142 in the retaining element extending from the hinge pins 140 in the direction remote from the interior chamber 118, including within the retaining device 112. These slot-shaped apertures 142 divide the retaining element 123 into respective retaining element parts 131 and 132, one on either side of the dividing plane 141. The hinge pins 140 may be of any type and may be provided in the form of joints, hinges, thinner regions of material, etc..

As illustrated in Fig. 18, in the section region of the dividing plane 141 with the container casing 116, a recess 143 extending through the latter is provided having a varying width across its longitudinal extension in the direction perpendicular to the dividing plane 141, starting from the closed end region 115 to the open end region 114. By preference, starting from the dividing plane 141, the width increases across a first part region of the recess 143 and after a certain distance from the end region 115 the width of the recess 143 decreases. The purpose of this recess 143 is to take advantage of the deformation properties of the holder container 111 and, as illustrated in Fig. 20, apply a compression force to the container casing 116 as shown by the arrows 144 so as to deform it, due to the presence of the recess 143, in such a way that the two retaining element parts 131, 132 are displaced towards one another about the hinge pins 140, thereby opening up the retaining device 112.

This compression force indicated by arrows 144 is preferably applied in the direction perpendicular

- 27 -

to the dividing plane 141 so that the recesses 143 provided in the container casing 116 on each side are also deformed, as a result of which the two retaining element parts 131, 132 will be moved away from one another in their end regions remote from the interior chamber 118 in accordance with the law of leverage, thereby enlarging the bore 124. A needle assembly 2 held in the retaining device 112 can then be easily released.

Figs. 21 to 23 provide a simplified, schematic diagram of another embodiment of the holding device 110, which may also be construed as an independent embodiment, the same reference numbers being used for components common to Figs. 1 to 20 described above. For the sake of simplicity and in order to avoid unnecessary repetition, reference may be made to the description of the preceding drawings for details of individual components or groups of components.

In the case of the embodiment illustrated as an example here, the holder container 111 as a whole is not illustrated since the specific design of the open end region 114 in particular is of no significance to the invention. The end wall 117 is provided in the section of the end region 115 of the holder container 111, in the plane 20 perpendicular to the longitudinal median axis 119, co-operating with the container casing 116 to enclose the interior chamber 118 of the holder container 111. An orifice 145 is provided through the end wall 117, centred on the longitudinal median axis 119. It has a clearance internal dimension corresponding at least to an external dimension of a positioning element 19 of the needle assembly 2, which is shown in a simplified schematic form. In the area of the closed end region 115, the holding device 110 also has a retaining device 146 for the simplified and schematically illustrated positioning element 19 of the needle assembly 2, which, in the embodiment illustrated in this example, comprises a positioning member 147 locating at least in certain regions with the container casing 116, several guide elements 148 projecting out from the end wall 117 in the direction remote from the interior chamber 118 and retaining elements 149 associated with the guide elements 148 and co-operating with the positioning member 147.

In this embodiment, co-operating guide elements 148 are severally distributed around the peripheral region of the end wall 117 in the plane 20 perpendicular to the longitudinal median axis 119, a dividing angle 150 being formed between each set of co-operating guide elements 148. In the embodiment illustrated as an example here, two guide elements 148 aligned parallel with one another co-operate with each of the retaining elements 149, the dividing angle 150 between the retaining ele-

- 28 -

ments 149 and the guide elements 148 co-operating therewith being calculated by dividing the full circle in the plane 20 by the number of retaining elements 149. In the particular embodiment illustrated here, the dividing angle 150 is 120° and the individual retaining elements 149 are divided symmetrically. The guide elements 148 arranged on either side of the retaining element 149 form a type of guiding system for the respective retaining elements 149 arranged in between them, enabling the retaining elements 149 to be respectively displaced as indicated by a double arrow 151 in a direction perpendicular to the longitudinal median axis 119 and parallel with the plane 20.

Figs. 21 and 23 provide simplified illustrations of the locked position of the retaining elements 149 for the positioning element 19 of the needle assembly 2, whilst Fig. 22 shows the retaining elements 149 in the released position or open position. In this embodiment, the positioning member 147 is substantially of a cap design and has an internal clearance dimension relative to the longitudinal median axis 119, in the form of an internal thread, which corresponds at least to an external diameter of the container casing 116 in the portion of the end region 115. As a result, a cylindrically shaped wall part 152 of the positioning member 147 of the container casing 116 can be engaged. In the direction parallel with the end wall 117 of the holder container 111 or in the direction parallel with the plane 20, the positioning member 147 also has another end wall 153 joined to the cylindrical wall part 152, which has another orifice 154, also centred on the longitudinal median axis 119.

An internal clearance dimension or an internal diameter of the orifice 154 may correspond in terms of dimensions to the orifice 154 in the end wall 117, although the orifice 154 could also be larger. It has been found to be of advantage if the orifice 154 has a clearance dimension corresponding to or larger than the external diameter 86 of the shoulder 81 of the positioning element 19 illustrated in Fig. 8. As a result, the shoulder 81 is brought into abutment with a surface 155 of the retaining element 149 remote from the end face 117 when the retaining elements 149 are in the screwed-in position and in the locked position. Clearly, however, the clearance internal dimension may be substantially the same as or smaller than the orifice 145, in which case when the retaining elements 149 are in the locked position the shoulder 81 of the positioning element 19 will abut against the external surface of the end wall 153.

In order to displace the individual retaining elements 149 from the locked position into the released position, the positioning member 147 is mounted so as to be able to pivot or rotate on the container

- 29 -

casing 116 relative to the longitudinal median axis 119. Because of the arrangement whereby the guide elements 148 project out from the end wall 117 and because the retaining elements 149 are arranged between the end wall 117 of the holder container 111 and the end wall 153 of the positioning member 47, the retaining elements 149 can be displaced by a pivoting or rotating motion of the positioning member 147 relative to the holder container 111 in the direction of the arrow 156 from the released position illustrated in Fig. 22 into the locked position illustrated in Fig. 23 and then back to the locked position.

In order to move the retaining elements 149 from the released position into the locked position or vice versa, each of the retaining elements 149 has at least one positioning element 157 projecting from the surface 155 thereof, which provides a driving link by means of a groove-shaped recess 158 set in the end wall 153 on the side facing the end wall 117 of the holder container 111. The distance of this groove-shaped recess 158 or track to the longitudinal median axis 119 varies across its longitudinal extension, which causes a displacement of the individual retaining elements 149 as indicated by the double arrows 151 in co-operation with the guide elements 148.

On the side facing the positioning element 19, each of the retaining elements 149 has at least a part region of an internal thread, so that when the retaining elements 149 are in the locked position, the positioning element 19 of the needle assembly 2 can be screwed in without problem. The extent of the displacement path of the retaining elements 149 and hence the displacement speed, due to the selected increase in the curve, can be fixed by an appropriate selection of the distance of the groove-shaped recess 158 relative to the longitudinal median axis 119. It has been found to be of advantage if the first part section of the groove-shaped recess 158 is selected so as to exhibit a relatively steep increase or be at an increasing or widening distance from the longitudinal median axis 119 since this will cause the individual retaining elements 149 to be opened rapidly, which means that the positioning element 19 and hence the needle assembly 2 attached thereto can be released after only a short displacement path operated by turning the positioning member 147.

In order to prevent the positioning member 147 from inadvertently working loose from the holder container 111, a safety device 159 may be provided between the wall part 152 of the positioning member 147 and the container casing 116 of the holder container 111, which on the one hand enables the positioning member 147 to be pivoted or rotated relative to the holder container 111 and on the

- 30 -

other holds the positioning member 147 on the holder container 111 so that it can not slide in the direction of the longitudinal median axis 119. This ensures that the distance between facing faces of the end wall 117 of the holder container 111 and the end wall 153 of the positioning member 147 is always constant or the same. The safety device 159 may be provided in the form of at least one annular or groove-shaped recess set into the container casing 116 and at least one projection or shoulder on the wall part 152 of the positioning member 147 co-operating with and engaging in this groove-shaped recess. Across its longitudinal extension, this groove-shaped recess may also be arranged in only certain regions of the container casing 116 in the circumferential direction, for example, in which case a length of this groove-shaped recess of the safety device 159 may correspond to the displacement path of the positioning member 147 relative to the holder container 111. The length of the groove-shaped recesses makes it easy to set exact end stops for both the locked position and the released position.

However, it would also be possible to provide the groove-shaped recess of the safety device 159 continuously around the circumference of the container casing 116, which will enable an unhindered rotating movement of the positioning member 147 relative to the holder container 111. The locked and released position can then be determined through the length of the groove-shaped recess 158 in the end wall 153 of the positioning member 147. With this embodiment, the safety device 159 merely serves to retain the positioning member 147 in a predeterminable position so that it is unable to slide on the holder container 111 in the direction of the longitudinal median axis 119.

If, for example, the safety device 159 is a continuous groove-shaped recess around the periphery, it is also possible, as illustrated in simplified form in Fig. 23, to provide a separate restricting device 160 between the positioning member 147 and the holder container 111 which will mark the two end positions between the positioning member 147 and the holder container 111 in conjunction with the retaining elements 149. Again, at least one but preferably several groove-shaped recesses extending across a part region of the circumference may be provided in the container casing 116, a length thereof corresponding to the relative displacement path between the positioning member 147 and the holder container 111. A shoulder or projection will engage in this groove-shaped recess, marking either the locked position or the released position at the respective end position. 90° has been found to be the preferred angle of rotation between the positioning member and the holder container 111. Clearly, however, it would also be possible to select a smaller or larger angle of rotation. A rotation

- 31 -

angle of approximately 90° makes for easy one-handed operation from the locked position into the released position and back again.

It has been found to be necessary and of advantage if the materials used for the holding device 1 can withstand sterilisation by steam. Accordingly, the holder body or the holder container 3 may be made from polypropylene (PP) and the slide 45, 120, the positioning member 147 and the retaining elements 149 from polyoxymethylene (POM). Furthermore, the material used for the slide 45 should be harder than that of the insert element or positioning element 19. This reduces or prevents damage or wear on the slide 45 when used over a longer period of time.

Figs. 24 and 25 illustrate another embodiment of the holding device 1 which may also be construed as an independent embodiment, the same reference numbers being used for parts which are common to Figs. 1 to 15. To avoid unnecessary repetition, reference should be made to the description of Figs. 1 to 15 for details of individual components or groups of components.

The holding device 1 again comprises the holder container 3 and the operating device 5, between which the guide device 6 is arranged. The design and layout of the guide elements 21 and 58 making up the guide device 6 may be as described with reference to Figs. 1 to 15. Supporting elements 34, 35 are again provided in the dividing plane 22 on the end wall 10 of the holder container 3, which support the positioning element 19 - see Fig. 1 - as the operating device 5, namely the slide 45, is displaced relative to the holder container 3. The orifice 17 in the end wall 10 is also centred on the longitudinal median axis 12 of the holder container 3. However, the orifice 17 and the two supporting elements 34, 35 could also be disposed off-centre or eccentrically relative to the holder container 3 or the longitudinal median axis 12 if the needle assembly 2 does not have to be aligned centrally to the container casing 9, which in this case is circular. This arrangement is freely selectable and will depend on the intended use or application of the holding device 1. Care should be taken to ensure that the individual components are adapted and disposed so as to produce the requisite displacement.

Fig. 24 illustrates the locked position between the slide 45 and the holder container 3, in which the retaining element 56 is substantially centrally aligned with the longitudinal median axis 12 or the orifice 17. In this initial position or locked position, the insert element or needle assembly 2 (omitted from the drawing for the sake of clarity) can be inserted in the retaining element 56 where it is re-

- 32 -

tained. The positioning element 19 is inserted in the retaining element 56 by a simple screwing action using the thread fittings. Clearly, instead of a thread fitting, it would also be possible to use an appropriate snap-fit connection or catch connection.

In the initial position or locked position illustrated, the end portion 77 of the slide 45 lies more or less in abutment with the end 37 of the supporting element 35 and the retaining element 56 is simultaneously also centred on the longitudinal median axis 12 or orifice 17. In order to prevent any undesirable sliding or displacement of the slide 45 relative to the holder container 3, a separate spring element 94 is provided in the slide 45 of this embodiment, and in this instance is supported on the end 36 of the supporting element 34.

To accommodate this spring element 94, the orifice 53 has a larger cross section on the side of the releasing element 57 remote from the retaining element so that the bent spring element 94 projects into this orifice. The design and layout of the spring element 94 inside the orifice 53 is not restricted to the three-dimensional arrangement described here and may be of any three-dimensional design that will impart a sufficient force to fix the slide 45 in its initial position or locked position relative to the holder container 3 on the one hand and ensure a simple displacement with sufficient return force on the other. The spring force applied by the spring element 94 to the end 36 of the supporting element 34 causes a compression force on the slide 45 in the region of the end portion 77 in the direction of the end 37 of the supporting element 35.

The spring element 94 could also be designed so that it is hardly or not deformed at all when the slide 45 is in the initial or locked position relative to the holder container 3 and therefore bears against the end 36 of the supporting element 34 without applying any spring force, in which case a spring force will not be created until the spring element 94 is deformed causing a displacement into the released position, which will in turn return the slide to the initial position or locked position once the needle assembly 2 has been released. This arrangement provides a simple mechanism whereby, when the released position, in which the needle assembly 2 or insert element is released from the holding device 1, is reached, the slide 45 is automatically returned.

In order to set the requisite amount of displacement force to be applied to the slide 45 in the direction of arrow 83, the slide 45 in this embodiment additionally has an orifice 96 respectively on either side

- 33 -

of the dividing plane 52 in the region of the orifice 53 between the latter and the side faces 48, 49, which extends through the slide 45, also in the direction of the orifice 53. In the embodiment illustrated as an example here, the orifices 96 extend in the longitudinal direction of the slide approximately between the end portion 77 (see Fig. 5) and the end of the releasing element 57 remote from this end portion 77. Accordingly, the displacement force to be applied in the direction of the arrow 83 is determined due to the fact that, depending on the selection and size of the orifice 96, a separate respective land 97 is formed between the latter and the orifice 17 in the region of the dividing plane 52, the land thickness 98 (see Fig. 14) being variable in a direction substantially perpendicular to the dividing plane depending on the size of the orifice 96.

Because of the differing dimensions of the retaining element 56 and the releasing element 57, the two lands 97 are angled relative to one another and subtend between them an acute angle which tapers starting from the releasing element 57 through to the retaining element 56 so that the two lands 97 run towards one another. Due to the layout of the orifice 96, the land width 98 is substantially constant across the longitudinal extension of the lands 97. The slimmer the land thickness 98, the lower the deformation force which needs to be applied in order to deform the two lands 97 transversely to the dividing plane 52 or in a direction perpendicular thereto. The transition from the retaining element 56 to the releasing element 57 and hence the resultant release of the positioning element 19 from the retaining element 56 can be easily adjusted and the displacement force predeterminably fixed and hence increased or reduced. As a result, the mid-distance 67 between the retaining element 56 and the releasing element 57 may also be selected so as to be greater or longer - as described above with reference to Figs. 5 and 6 - to improve the hold on the insert element or positioning element 19 in the locked position.

At least one recess 99 may also be provided in the region of the bearing face 46 (see Fig. 4) of the slide 45 in order to reduce the size of the bearing face 46 on the face 16 of the end wall 10. This also makes for a certain saving on materials. However, in order to increase the entire screwing depth by providing at least one recess 99 in the region of the bearing face 46, the retaining element 56 may also be designed to extend across the entire thickness of the slide 45. As a result, a bearing face 46 is formed in the region of the retaining element 56 which will rest on the face 16 of the end wall 10, the bearing in this region providing a support against the end wall 10 and thereby preventing any deformation during the screwing process. At the same time, because of the longer screwing depth through

- 34 -

the full thickness of the slide 45, the hold on the needle assembly 2 is also firmer and more secure when the holding device 1 is used for its intended purpose.

By selecting the size of the recess 99 and the associated weakening of the slide 45, the thickness of the lands 97 and the associated deformation force which needs to be applied for the displacement process can be determined. The greater the size of the recess 99, the smaller the thickness of the lands 97 in the direction perpendicular to the top face 47. Similarly, a projection 100 may be provided on the slide 45, extending from the bearing face 46 of the slide 45 in the direction remote from the top face 47.

As may be seen by comparing Figs. 24 and 25, a checking device 161, which may be released as required, is provided between the slide 45 and the wall or end wall 10 of the holder container 3, arranged on both sides, in particular centrally relative to the dividing plane 52 as well as on both sides of the orifice 17. The checking device 161 could also be provided on only one of the two sides of the dividing plane 52. If the checking device 161 is arranged in a symmetrical layout, it will have several checking elements 162 - two checking elements 162 in the embodiment illustrated - disposed on the wall or end wall 10 of the holder container 3 on the side remote from the interior chamber 11 and projecting out from the wall or end wall 10 on the side remote from the interior chamber 11. These two checking elements 162 are disposed in a normal plane 163 running at a right angle to the dividing plane 22 and through the longitudinal median axis 12. These checking elements 162 are disposed on the wall or end wall 10 of the holder container 3 in such a way that they project into the orifices 96 of the slide 45 and abut against side faces 164 of the lands 97 remote from the orifice 53, at least in certain regions, when the slide 45 and the holder container 3 are in the locked position

In the locked position the retaining element 56 is centrally aligned on the longitudinal median axis 12 so that the needle assembly 2 can be screwed into the slide 45. In order to impart sufficient lateral stability to the two lands 97 in conjunction with the variable land thickness 98, the two lands 97 may be elastically deformed so that the retaining element 56 can be widened so that it no longer securely holds the needle assembly 2. This widening occurs substantially in the normal plane 163. In order to permit a corresponding displacement of the slide 45 relative to the holder container 3 as indicated by the arrow 83, the checking elements 162 on the end wall 10 must take account of the design and inclination of the side faces 164 of the lands 97 so that they can be displaced accordingly without hindrance.

- 35 -

In the embodiment illustrated, because the side faces 164 run at an angle, they have to be provided with other checking elements 165 which, in the locked position, co-operate with the checking elements 162 on the holder container 3, thereby forming the checking device 161. These other checking elements 165 project from the side faces 164 on the side remote from the orifice 53 and extend into the orifices 96 of the slide 45. Because the side faces 164 run towards one another in a conical arrangement, the overlap of the other checking elements 165 beyond the side faces 164 must be selected so that when the slide 45 is displaced from the locked position into the released position the checking elements 162 no longer abut with the side faces 164 or can not do so until the released position.

The co-operation of the checking elements 162 with the other checking elements 165 in turn prevents the retaining element 56 from widening in the locked position, so that the needle assembly 2 is guaranteed to remain securely retained or fixed when the holding device 1 is used for its intended purpose. As a result of this co-operation between the checking elements 162 and the other checking elements 165, the checking device 161 is engaged when the slide is in the locked position and disengaged in the released position.

As described in more detail with reference to Figs. 1 to 15 above, the supporting faces 73, 74 may also be provided accordingly on the top face 47.

For the sake of good order, it should finally be pointed out that in order to provide a clearer understanding of the structure of the holding device, in particular the retaining device, they and their constituent parts have been illustrated out of scale to a certain extent and/or on an enlarged and/or reduced scale.

The tasks underlying the independent inventive solutions can be found in the description.

Above all, subject matter relating to the individual embodiments illustrated in Figs. 1, 2, 3, 4, 5, 6, 7, 8; 9, 10, 11, 12; 13, 14, 15; 16, 17; 18, 19, 20; 21, 22, 23; 24, 25 can be construed as independent solutions proposed by the invention. The tasks and solutions to which they relate can be found in the detailed descriptions relating to these drawings.

Reference Numbers

1	Holding device	31	Guide surface
2	Needle assembly	32	Guide surface
3	Holder container	33	Guide surface
4	Retaining device	34	Support member
5	Operating device	35	Support member
6	Guide device	36	End
7	End region	37	End
8	End region	38	Distance
9	Container casing	39	Thickness
10	End wall	40	Dimension
11	Interior chamber	41	End
12	Longitudinal median axis	42	End
13	Face (internal 9)	43	Support surface
14	Face (internal 11)	44	Support surface
15	Face (external 9)	45	Slide
16	Face (external 11)	46	Bearing face
17	Orifice	47	Top face
18	Cannula	48	Side face
19	Positioning member	49	Side face
20	Plane	50	Side face
21	Guide element	51	Side face
22	Dividing plane	52	Dividing plane
23	Profiled section	53	Orifice
24	Leg	54	Length
25	Leg	55	Width
26	Leg	56	Retaining element
27	Leg	57	Releasing element
28	Guide surface	58	Guide element
29	Guide surface	59	Indentation
30	Guide surface	60	Indentation

- 37 -

61	Slide face	91	Catch element
62	Slide face	92	Distance
63	Slide face	93	Longitudinal distance
64	Slide face	94	Spring element
65	Length	95	Arrow
66	Longitudinal dimension	96	Orifice
67	Mid-distance	97	Land
68	Bore	98	Land thickness
69	Thread	99	Recess
70	Internal dimension	100	Projection
71	Recess		
72	Clearance width		
73	Support surface		
74	Support surface		
75	Start		
76	End		
77	End portion		
78	End portion		
79	Continuation		
80	External thread	110	Holding device
81	Shoulder	111	Holder container
82	Distance	112	Retaining device
83	Arrow	113	Operating device
84	Arrow	114	End region
85	Distance	115	End region
86	External dimension	116	Container casing
87	Catch device	117	End wall
88	Catch element	118	Interior chamber
89	Catch element	119	Longitudinal median axis
90	Distance	120	Slide

121	Surface	151	Double arrow
122	Shoulder	152	Wall part
123	Retaining element	153	End wall
124	Bore	154	Orifice
125	Thread	155	Surface
126	Double arrow	156	Arrow
127	End wall part	157	Positioning element
128	End wall part	158	Recess
129	End wall part	159	Safety device
130	Orifice	160	Restricting device
131	Retaining element part	161	Checking device
132	Retaining element part	162	Checking element
133	Retaining element part	163	Normal plane
134	Length	164	Side faces
135	Positioning element	165	Checking element
136	Wall part		
137	Wall part		
138	Wall part		
139	Arrow		
140	Pivot axis		
141	Dividing plane		
142	Aperture		
143	Recess		
144	Arrow		
145	Orifice		
146	Retaining device		
147	Positioning member		
148	Guide element		
149	Retaining element		
150	Dividing angle		

C l a i m s

1. Holding device for an insert element having a holder body and a wall with an orifice running therethrough, through which a longitudinal median axis runs, having a retaining device disposed in the region of an external face of the wall, having an operating device by means of which the retaining device is designed to be displaced from a locked position into a released position, and having a guide device comprising guide elements engaging with one another to enable the operating device to be displaced relative to the holder body in a plane perpendicular to the longitudinal median axis, characterised in that the operating device (5) is provided in the form of a single-piece, plate-shaped slide (45) having an orifice (53) therein perpendicular to the plane (20) and the retaining device (4) being additionally disposed in the orifice (53), one part of the orifice (53) forming a retaining element (56) and another part a releasing element (57), and at least two diametrically opposed supporting elements (34, 35) are provided on the external face (16) of the wall, being arranged so as to project out from the external face (16) of the wall in the direction of the side remote from the interior chamber (11) and engaging at certain regions in the orifice (53) and in the end wall (10) adjacent to the orifice (17).

2. Holding device as claimed in claim 1, characterised in that the holder body is a holder container (3), having end regions (7, 8) spaced at a distance apart, between which a container casing (9) extends and the first end region (7) is open and the other end region (8) is closed off by an end wall (10) and the container casing (9) and the end wall (10) enclose an interior chamber (11), a longitudinal median axis (12) extending through the centre thereof between the two end regions (7, 8), wherein the container casing (9) and the end wall (10) respectively have an internal face (13, 14) directed towards the interior chamber (11) and an external face (15, 16) on the side remote from the interior chamber (11).

3. Holding device as claimed in claim 1 or 2, characterised in that the slide (45) has a bearing face (46) directed towards the wall of the holder body or the end wall (10) of the holder container (3), a top face (47) spaced at a distance therefrom and side faces (48 to 51) extending in between, and the orifice (53) disposed in the slide (45) extends between the bearing face (46) and the top face (47) and has a length (54) and a width (55).

- 40 -

4. Holding device as claimed in one or more of the preceding claims, characterised in that at least a first guide element (21) of the guide device (6) is disposed on the wall of the holder body or end wall (10) of the holder container (3) and at least another guide element (58) is disposed on the slide (45).
5. Holding device as claimed in one or more of the preceding claims, characterised in that the length (54) of the orifice (53) is greater than the width (55) thereof.
6. Holding device as claimed in one or more of the preceding claims, characterised in that the length (54) of the orifice (53) is greater than a largest distance (38) between ends (36, 37) of the two supporting elements (34, 35) remote from one another.
7. Holding device as claimed in one or more of the preceding claims, characterised in that facing ends (41, 42) of the supporting elements (34, 35) respectively form a support surface (43, 44) disposed immediately adjoining the orifice (17) in the end wall (10).
8. Holding device as claimed in one or more of the preceding claims, characterised in that the support surfaces (43, 44) are aligned parallel with one another and parallel with the longitudinal median axis (12).
9. Holding device as claimed in one or more of the preceding claims, characterised in that the facing support surfaces (43, 44) are concave in shape.
10. Holding device as claimed in one or more of the preceding claims, characterised in that the facing support surfaces (43, 44) are formed by a part of a cylindrical surface and a mid-point of curvature of these part faces runs through the longitudinal median axis (12).
11. Holding device as claimed in one or more of the preceding claims, characterised in that the retaining element (56) in the slide (45) is a bore (68) with an internal thread (69), the clearance internal dimension (70) of which is greater than the width (55) of the orifice (53).
12. Holding device as claimed in one or more of the preceding claims, characterised in that the

- 41 -

releasing element (57) is preferably an annular recess (71) through the slide (45), the internal clearance width (72) of which is greater than the clearance internal dimension (70) of the retaining element.

13. Holding device as claimed in one or more of the preceding claims, characterised in that the retaining element (56) forming the bore (68) and the releasing element (57) forming the recess (71) are aligned parallel with one another and perpendicular to the bearing face (46) and top face (47) of the slide.

14. Holding device as claimed in one or more of the preceding claims, characterised in that the retaining element (56) forming the bore (68) and the releasing element (57) forming the recess (71) are disposed adjacent to one another in the slide (45) in the direction of the length (65) of the orifice (53).

15. Holding device as claimed in one or more of the preceding claims, characterised in that the retaining element (56) forming the bore (68) and the releasing element (57) forming the recess (71) are disposed overlapping with one another in the slide (45) in the direction of the length (65) of the orifice (53).

16. Holding device as claimed in one or more of the preceding claims, characterised in that a mid-distance (67) between the bore (68) and the recess (71) is the same as or smaller than half the sum of the clearance internal dimension (70) of the bore (68) plus the internal clearance width (72) of the recess (71).

17. Holding device as claimed in one or more of the preceding claims, characterised in that the length (54) of the orifice (53) is dimensioned so that when the retaining element (56) is disposed in a coinciding or centred alignment in the slide (45) and with the orifice (17) extending through the wall or end wall (10), a first end portion (77) of the orifice (53) is in abutment with one of the opposing ends (37) of the support element (35) and when the releasing element (57) is disposed in a coinciding or centred alignment in the slide (45) and with the orifice (17) extending through the wall or end wall (10), another end portion (78) of the orifice (53) at another end (36) spaced at a distance apart from the first end portion (77) lies against the other supporting element (34) on the side remote from the

- 42 -

first end (37) of the first supporting element (35), the first position being the locked position and the other position being the released position.

18. Holding device as claimed in one or more of the preceding claims, characterised in that a support surface (73, 74) is provided on the top face (47) of the slide (45) respectively on either side of the orifice (53), which is designed to run at an incline relative to the top face (47) across its longitudinal extension, a start (75) of the support surface (73, 74) being disposed in the region of the orifice (71) in the slide (45) and an end (76) thereof in the region of the other end of the orifice (53).

19. Holding device as claimed in one or more of the preceding claims, characterised in that the start (75) of the support surface (73, 74) is disposed running substantially flush with the top face (47) and the end (76) of the support face (73, 74) projects out from the top face (47).

20. Holding device as claimed in one or more of the preceding claims, characterised in that the support surface (73, 74) is inclined at an angle of between 5° and 30° to the top face (47).

21. Holding device as claimed in one or more of the preceding claims, characterised in that the guide device (6) on the holder container (3) comprises at least two, preferably diametrically disposed guide elements (21) which project out from the end wall (10) of the holder container (3).

22. Holding device as claimed in one or more of the preceding claims, characterised in that the two guide elements (21) on the holder container (3) are provided as a profiled section (23) with a substantially L-shaped cross section, one respective leg (24, 25) of the profiled section (23) facing the end wall (10) of the holder container (3) and being joined thereto whilst another respective leg (26, 27) of the profiled section (23) faces the respective oppositely lying leg (24, 25) and the individual legs (24 to 27) of the profiled section (23) on the side facing the end wall (10) form guide surfaces (28 to 33).

23. Holding device as claimed in one or more of the preceding claims, characterised in that the other legs (26, 27) of the profiled section (23) are arranged at a distance from the external face (16) of the end wall (10).

- 43 -

24. Holding device as claimed in one or more of the preceding claims, characterised in that the individual guide surfaces (28 to 33) of the legs (24 to 27) are aligned parallel with one another and parallel with the longitudinal extension of the supporting elements (34, 35).
25. Holding device as claimed in one or more of the preceding claims, characterised in that the individual guide surfaces (28 to 33) of a guide element (21) are disposed perpendicular to one another extending in a plane perpendicular to their longitudinal extension.
26. Holding device as claimed in one or more of the preceding claims, characterised in that the other guide elements (58) on the slide (45) are indentations (59, 60) arranged on either side of the slide (45) in the transition region between the top face (47) and the side faces (48, 49) which are preferably arranged parallel with one another.
27. Holding device as claimed in one or more of the preceding claims, characterised in that each of the indentations (59, 60) is bounded by slide faces (61 to 64) extending parallel with the longitudinal extension of the orifice (53) in the slide (45).
28. Holding device as claimed in one or more of the preceding claims, characterised in that a length (65) of the slide faces (61 to 64) in the slide (45) corresponds to at least a longitudinal dimension (66) of the guide element (21) on the holder container (3) plus the mid-distance (67) between the bore (68) and the recess (71) in the slide (53).
29. Holding device as claimed in one or more of the preceding claims, characterised in that a catch device (87) is provided between the holder body or holder container (3) and the slide (45).
30. Holding device as claimed in one or more of the preceding claims, characterised in that the catch device (87) is provided in the form of catch elements (88, 89, 91) which can be engaged with one another, at least a first catch element (88, 89) being disposed on the external face (16) of the wall or end wall (10) and at least another catch element (91) on the bearing face (46) of the slide (45) facing the external face (16).
31. Holding device as claimed in one or more of the preceding claims, characterised in that the

catch device (87) is provided in the form of catch elements (88, 89, 91) which can be engaged with one another, at least a first catch element (88, 89) being disposed on one of the guide faces (28 to 33) of a guide element (21) and at least another catch element (91) on at least one slide face (61 to 64) of the indentation (59, 60) in the slide (45) facing these guide faces (28 to 33).

32. Holding device as claimed in one or more of the preceding claims, characterised in that the first catch element (88, 89) is a preferably spherically shaped recess in the wall or end wall (10).

33. Holding device as claimed in one or more of the preceding claims, characterised in that the other catch element (91) is a projection on the bearing face of the slide (45) which is preferably arranged so as to complement the first catch element (88, 89).

34. Holding device as claimed in one or more of the preceding claims, characterised in that several catch elements (88, 89) are provided in the wall or end wall (10) spaced at a distance (90) apart in a direction perpendicular to a dividing plane (22), the dividing plane (22) being disposed in the longitudinal median axis (12) and running through the diametrically opposite supporting elements (34, 35).

35. Holding device as claimed in one or more of the preceding claims, characterised in that the catch elements (88, 89) are centred on the dividing plane (22).

36. Holding device as claimed in one or more of the preceding claims, characterised in that the catch elements (88, 89) are spaced apart from one another at a longitudinal distance (93) from a transverse plane disposed perpendicular to the dividing plane (22) and parallel with the longitudinal median axis (12) perpendicular thereto and the longitudinal distance (93) corresponds to the mid-distance (67) between the retaining element (56) and the releasing element (57).

37. Holding device as claimed in one or more of the preceding claims, characterised in that when the catch element (91) of the slide (45) is engaged with the first catch element (88) of the wall or end wall (10), the retaining element (56) is aligned so as to coincide with the orifice (17).

38. Holding device as claimed in one or more of the preceding claims, characterised in that

- 45 -

when the catch element (91) of the slide (45) is engaged with the other catch element (89) of the wall or end wall (10), the releasing element (57) is aligned so as to coincide with or be centred on the orifice (17).

39. Holding device as claimed in one or more of the preceding claims, characterised in that a projection (100) is provided on the slide (45) on the bearing face (46) of the slide (45) extending in the direction remote from the top face (47), which is disposed on the bearing face (46) in the region of the side face (50) so that the latter is moved to bear against the external face (15) of the container casing (9) when the slide (45) is in the released position.

40. Holding device as claimed in one or more of the preceding claims, characterised in that at least one spring element (94) is provided between the slide (45) and the holder body or holder container (3).

41. Holding device as claimed in one or more of the preceding claims, characterised in that the spring element (94) bears against one of the spaced apart ends (36, 37) of the supporting elements (34, 35), preferably applying a biasing force.

42. Holding device as claimed in one or more of the preceding claims, characterised in that in the locked position or initial position, the first end portion (77) of the orifice (53) in the slide (45) abuts with one of the spaced apart ends (37) of the supporting element (35) and the spring element (94) is supported on the end (36) remote therefrom of the other supporting element (34).

43. Holding device as claimed in one or more of the preceding claims, characterised in that when the slide (45) is displaced from the locked position or initial position into the released position, the slide (45) is automatically returned to the locked position or initial position by the spring element (94).

44. Holding device as claimed in one or more of the preceding claims, characterised in that at least one other orifice (96) is provided in the slide (45) extending in the direction of the longitudinal median axis (12) between the orifice (53) in the slide (45) and the longer side faces (48, 49) thereof.

- 46 -

45. Holding device as claimed in one or more of the preceding claims, characterised in that the orifice (96) extends in the direction of the side faces (48, 49) starting from the end portion (77) of the orifice (53) as far as the region of the releasing element (57).
46. Holding device as claimed in one or more of the preceding claims, characterised in that at least one land (97) is provided between the orifice (53) and the orifice (96) having a land thickness (98).
47. Holding device as claimed in one or more of the preceding claims, characterised in that two lands (97) are provided on either side of the orifice (53).
48. Holding device as claimed in one or more of the preceding claims, characterised in that the two lands (97) subtend an angle α , the lands (97) being disposed so that they run towards one another starting from the releasing element (57) in the direction towards the retaining element (56).
49. Holding device as claimed in one or more of the preceding claims, characterised in that at least one recess (99) is provided in the bearing face (46) of the slide (45).
50. Holding device as claimed in one or more of the preceding claims, characterised in that a checking device (161) which can be released as required is provided between the slide (45) and the wall or end wall (10).
51. Holding device as claimed in one or more of the preceding claims, characterised in that the checking device (161) is engaged in the locked position between the slide (45) and the wall or end wall (10) and in the released position is disengaged.
52. Holding device as claimed in one or more of the preceding claims, characterised in that the checking device (161) comprises checking elements (162, 165) disposed on either side of the dividing plane (22).
53. Holding device as claimed in one or more of the preceding claims, characterised in that at least two checking elements (162) are provided on the wall or end wall (10) in a normal plane (163)

- 47 -

disposed at a right angle to the dividing plane (22) and running through the longitudinal median axis (12) and project from the wall or end wall (10) on the side remote from the interior chamber (11) and lie at least in certain regions against side faces (164) of the lands (97) remote from the orifice (53) in the locked position between the slide (45) and the wall or end wall (10).

54. Holding device as claimed in one or more of the preceding claims, characterised in that the other checking elements (165) are disposed on the side faces (164) of the lands (97) remote from the orifice (53) and these checking elements (165) project from the side faces (164) on the side remote from the orifice (53) so that in the locked position between the slide (45) and the wall or end wall (10) the first checking elements (162) lie against the other checking elements (164).

Fig.1

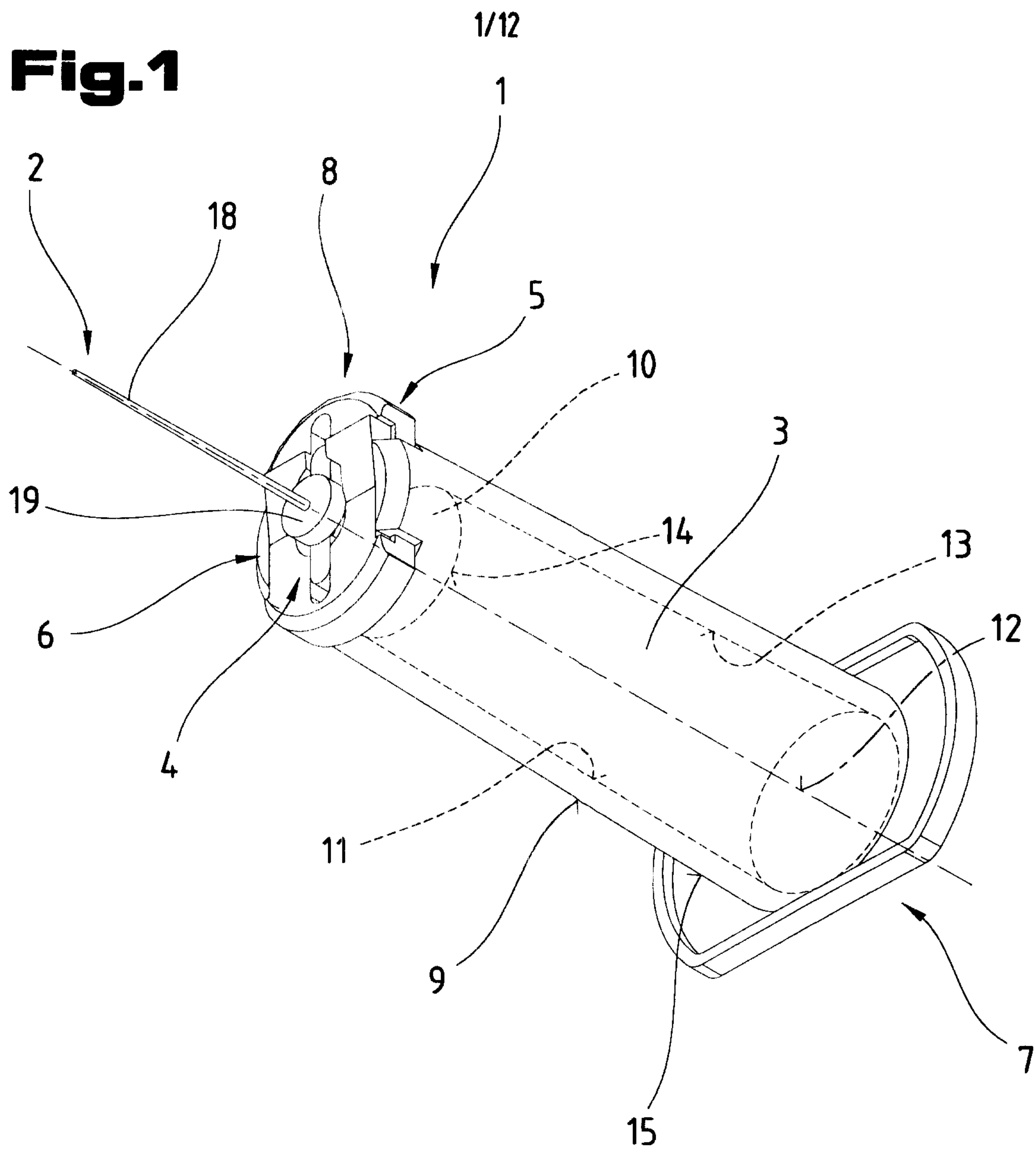

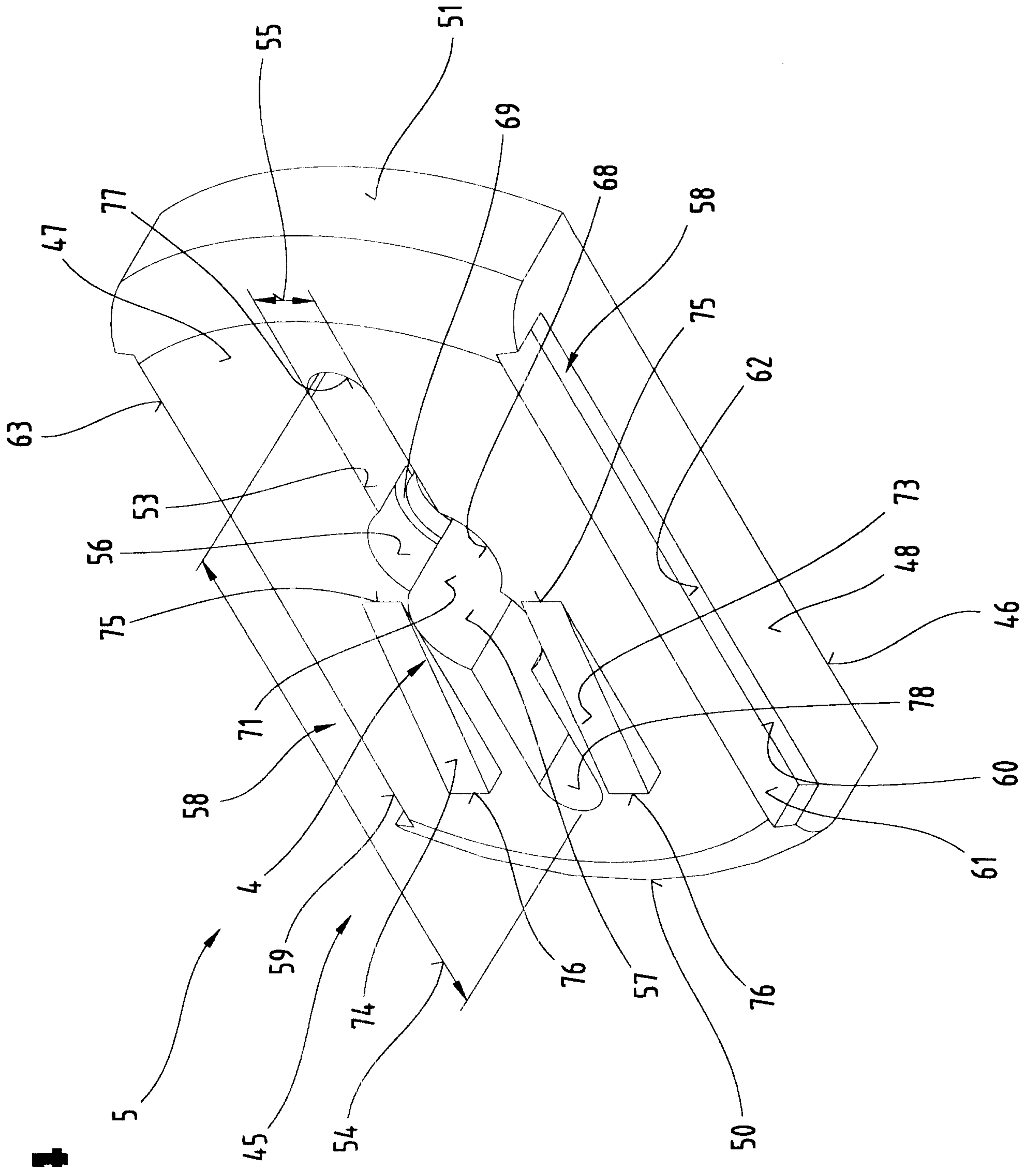

Fig.4

4/12

Fig.5

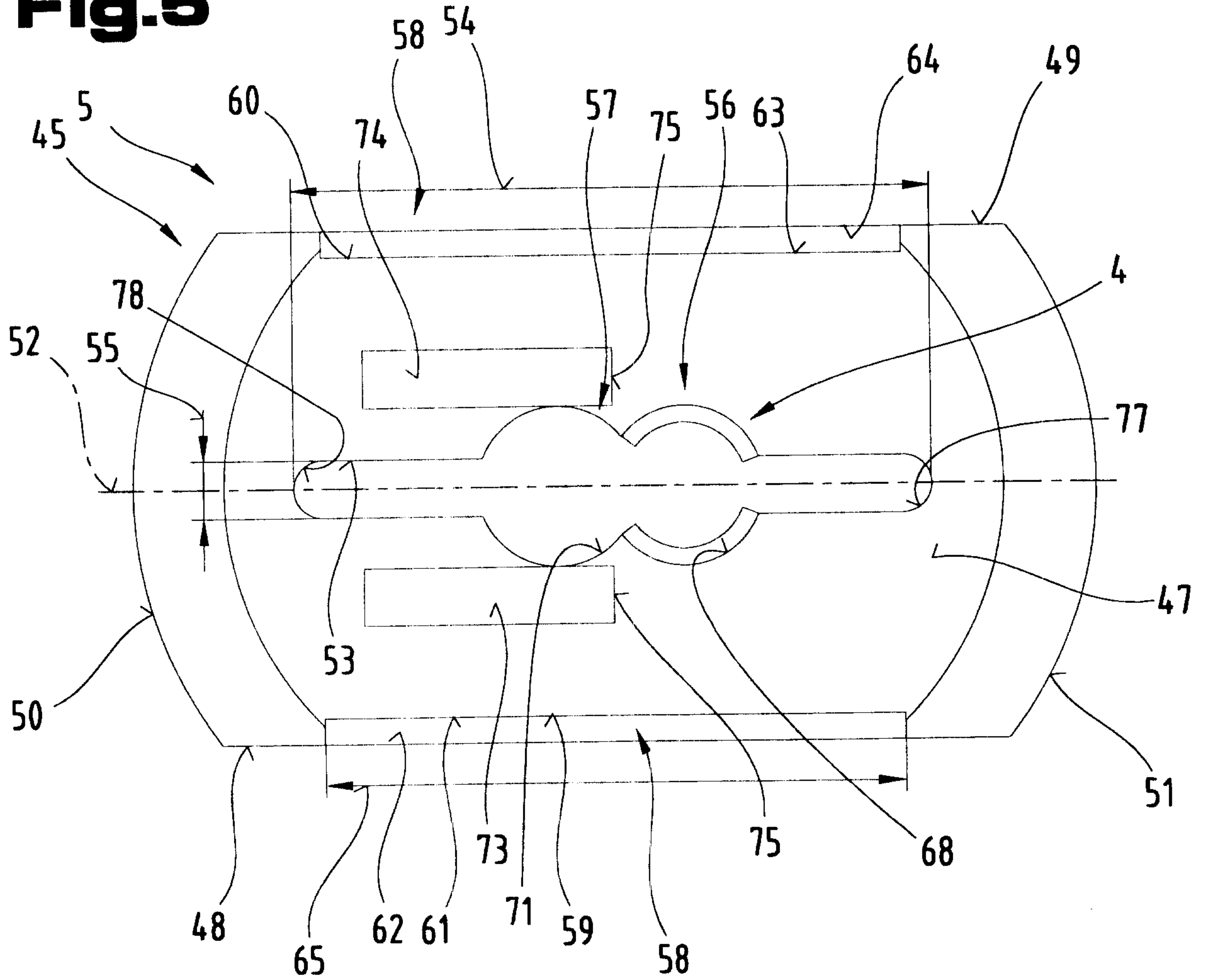

Fig.6

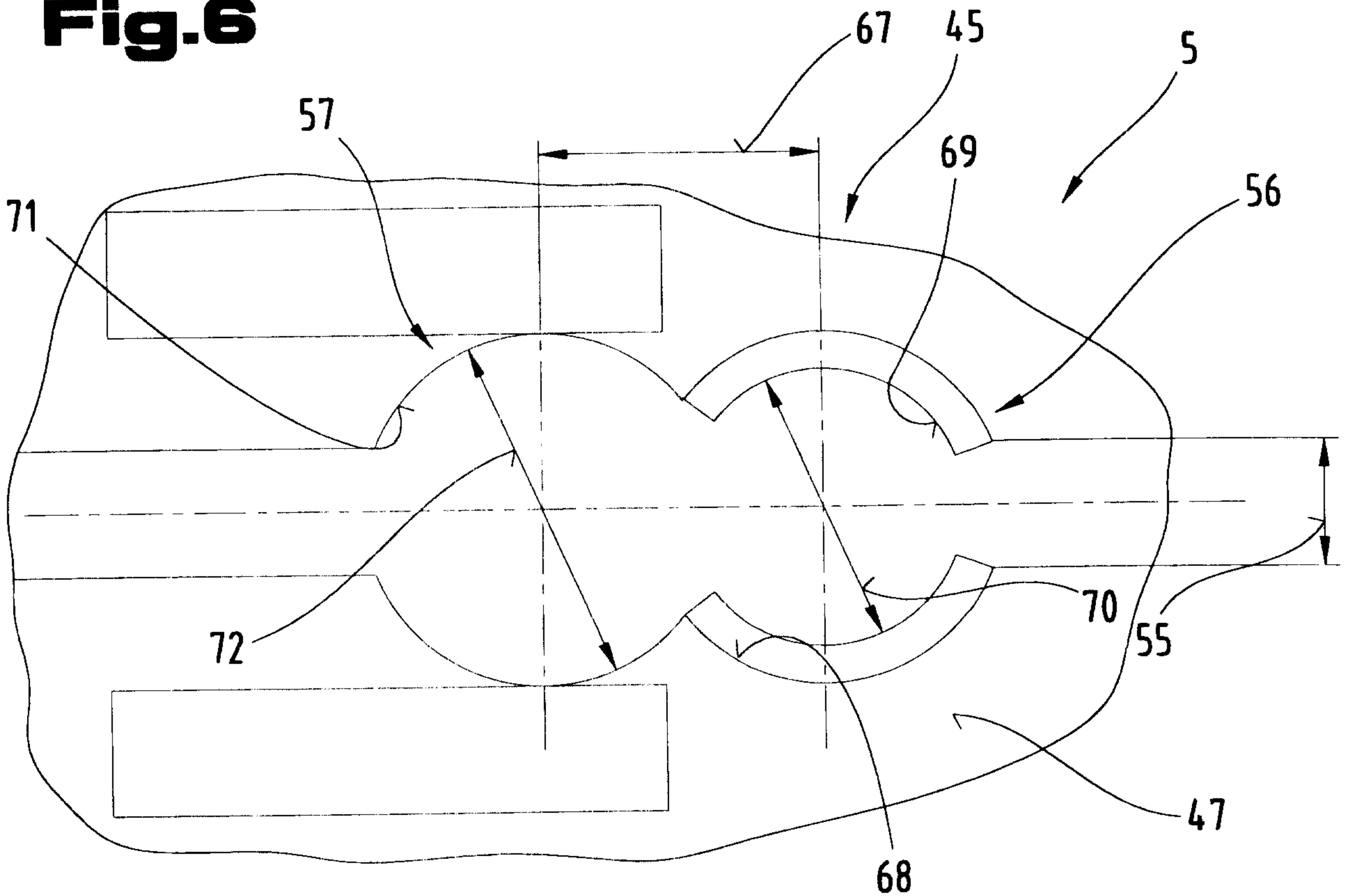

Fig.9

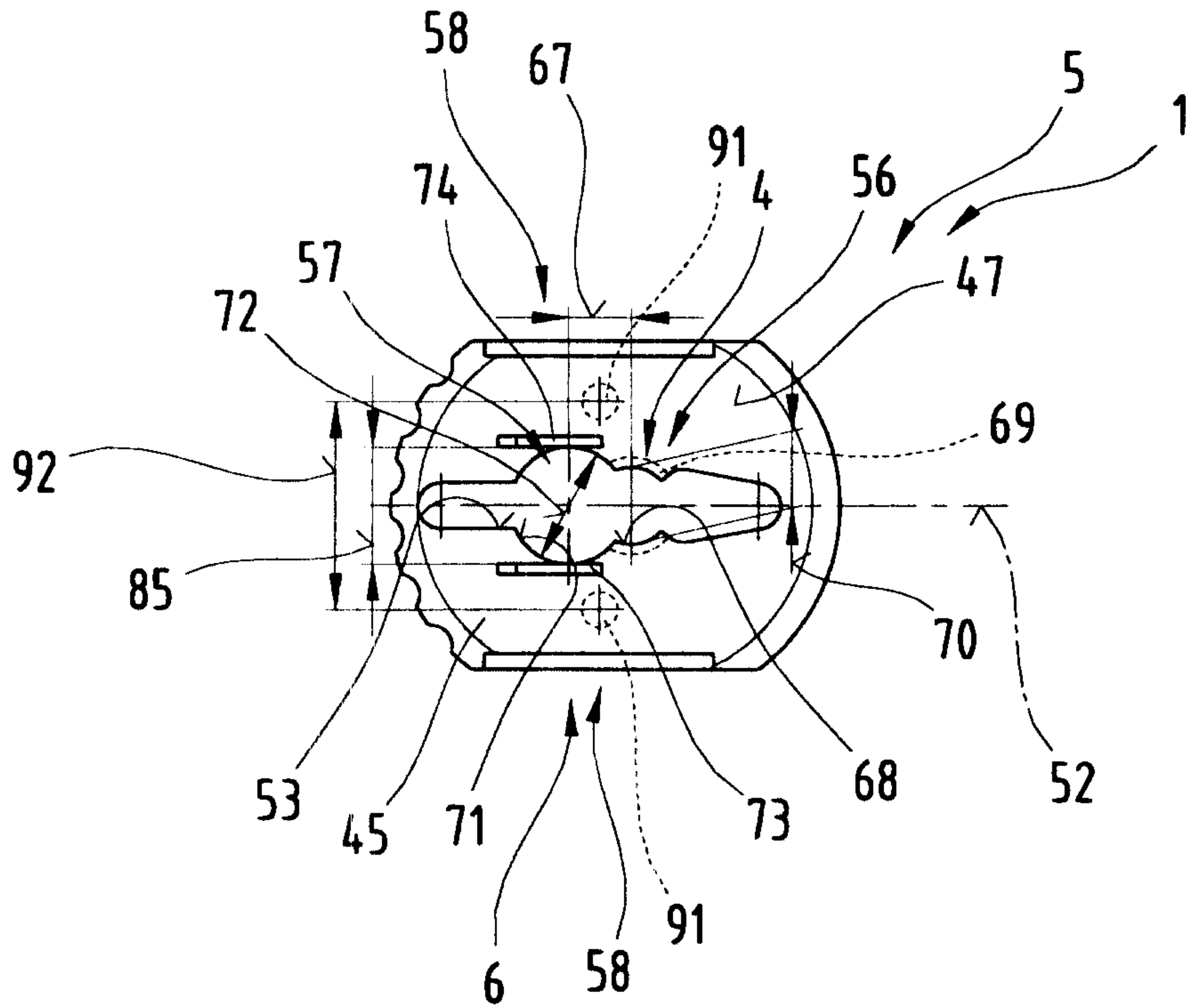

Fig.10

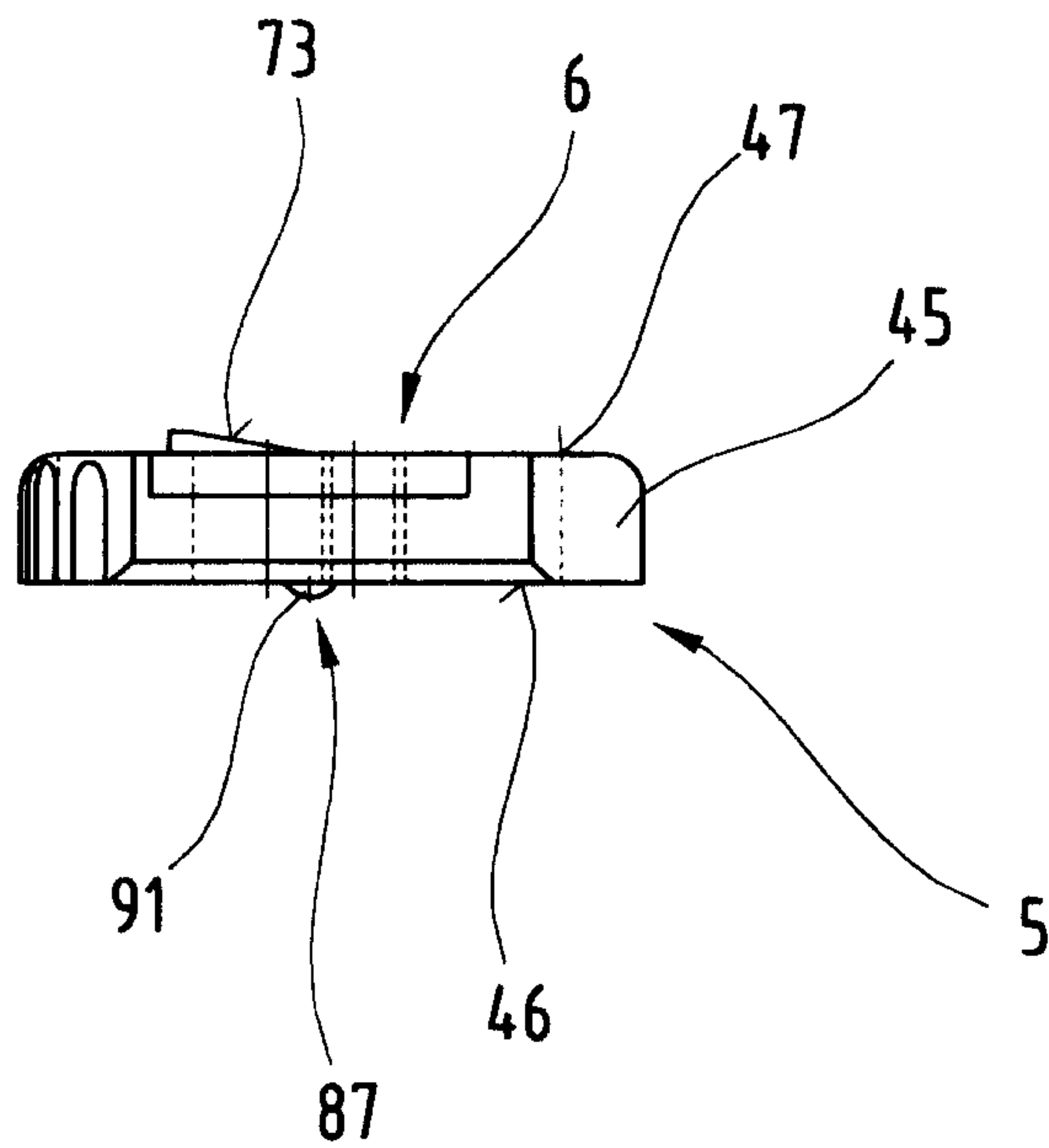

Fig.11

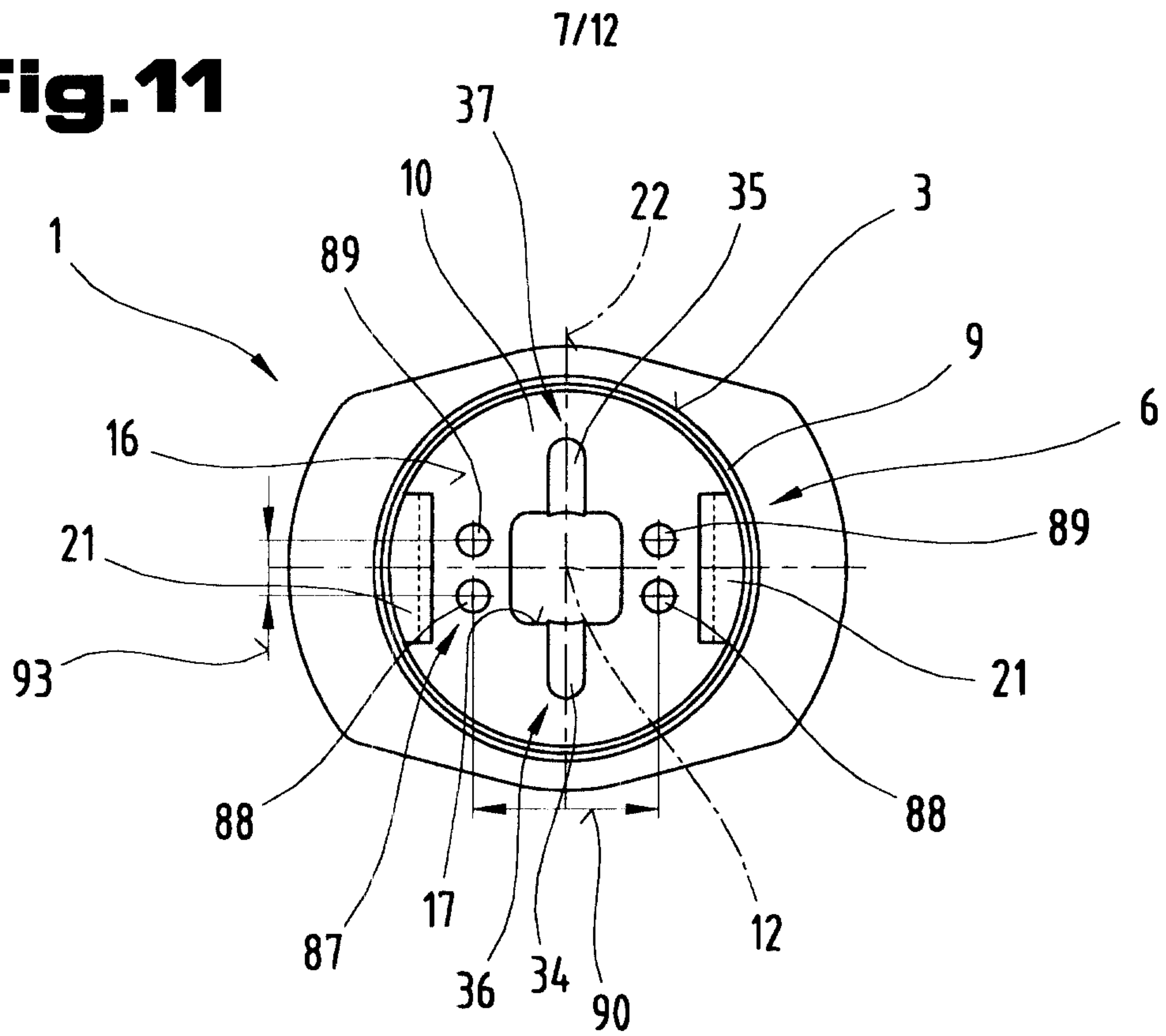

Fig.12

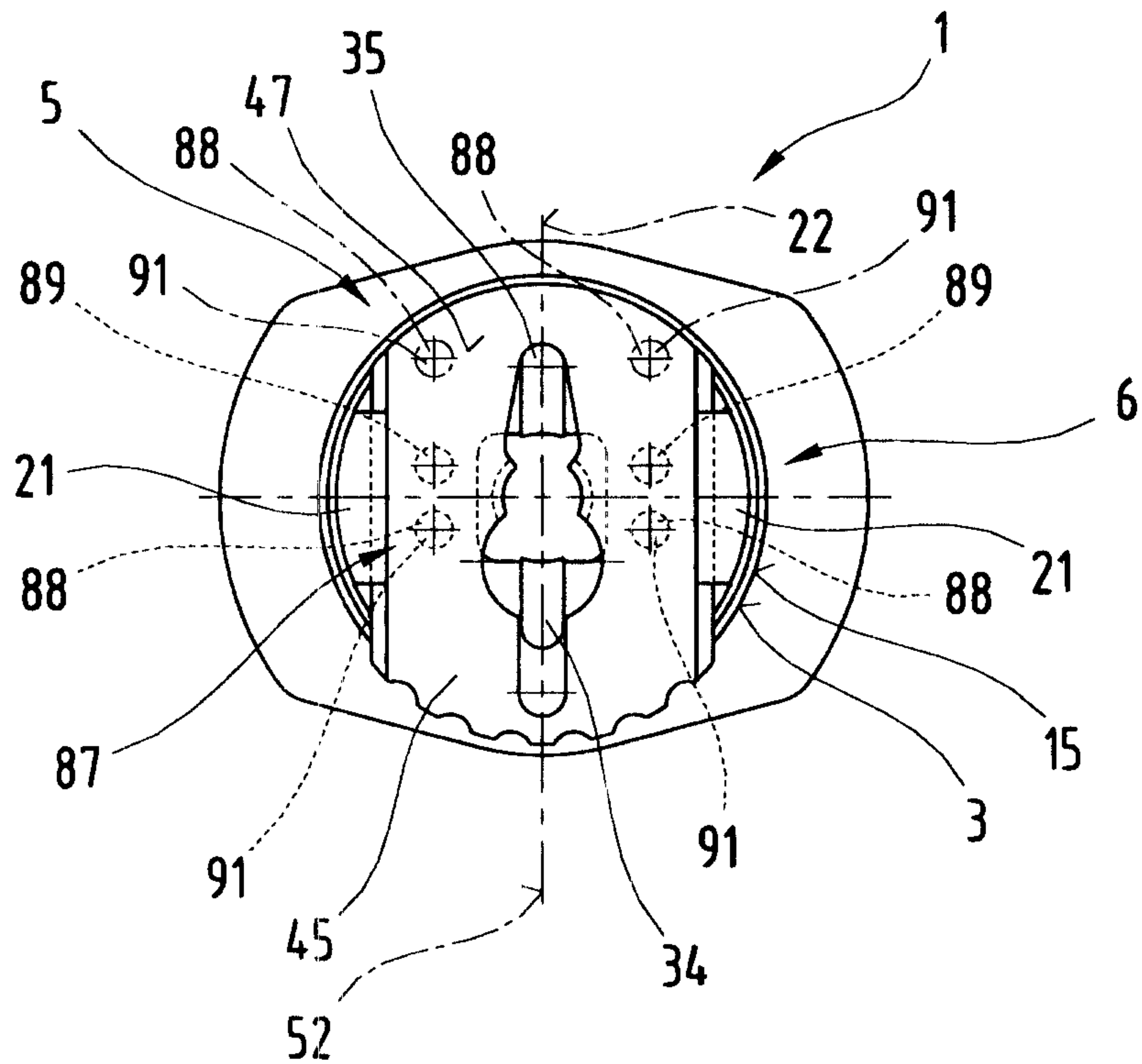

Fig.13

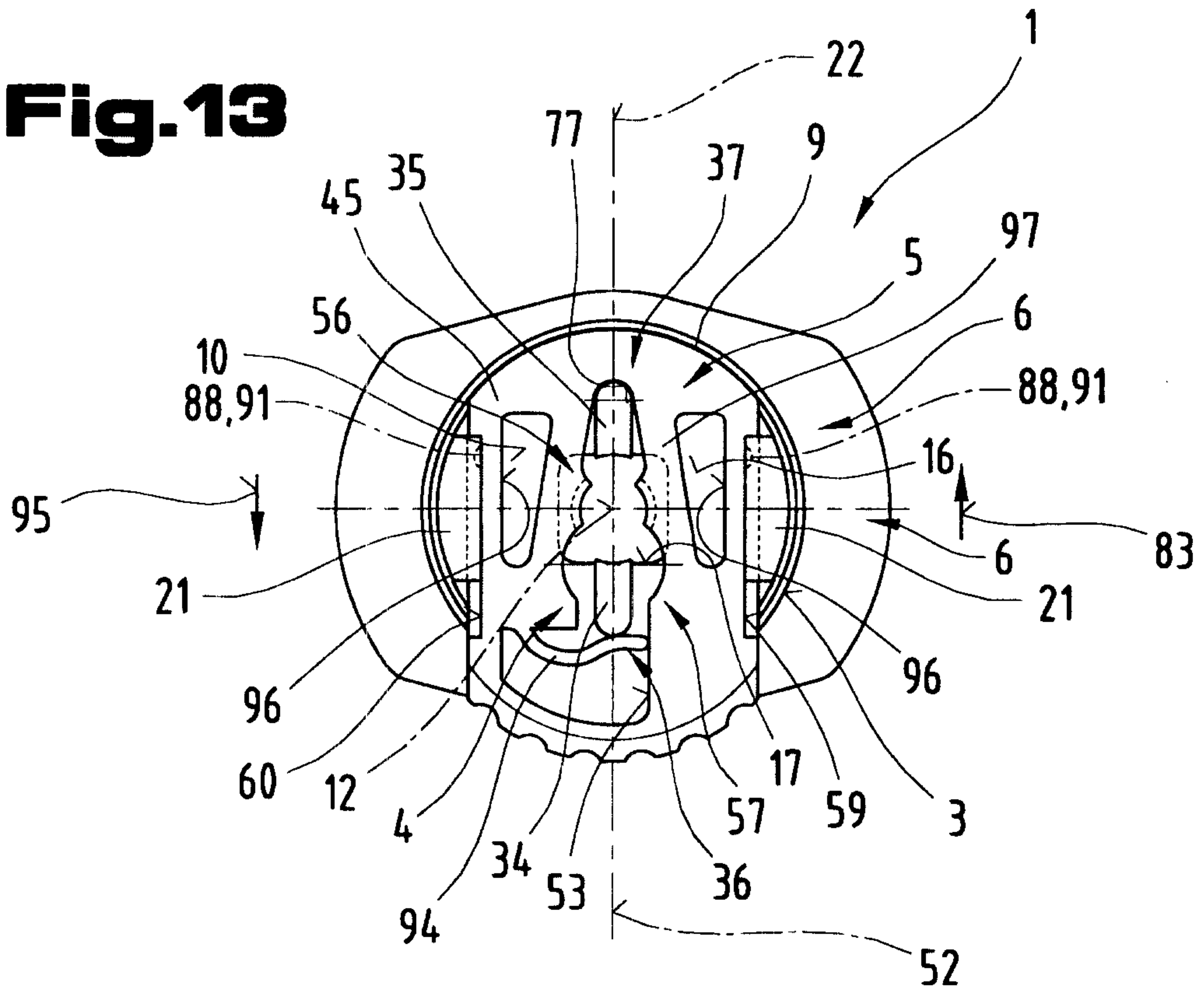

Fig.14

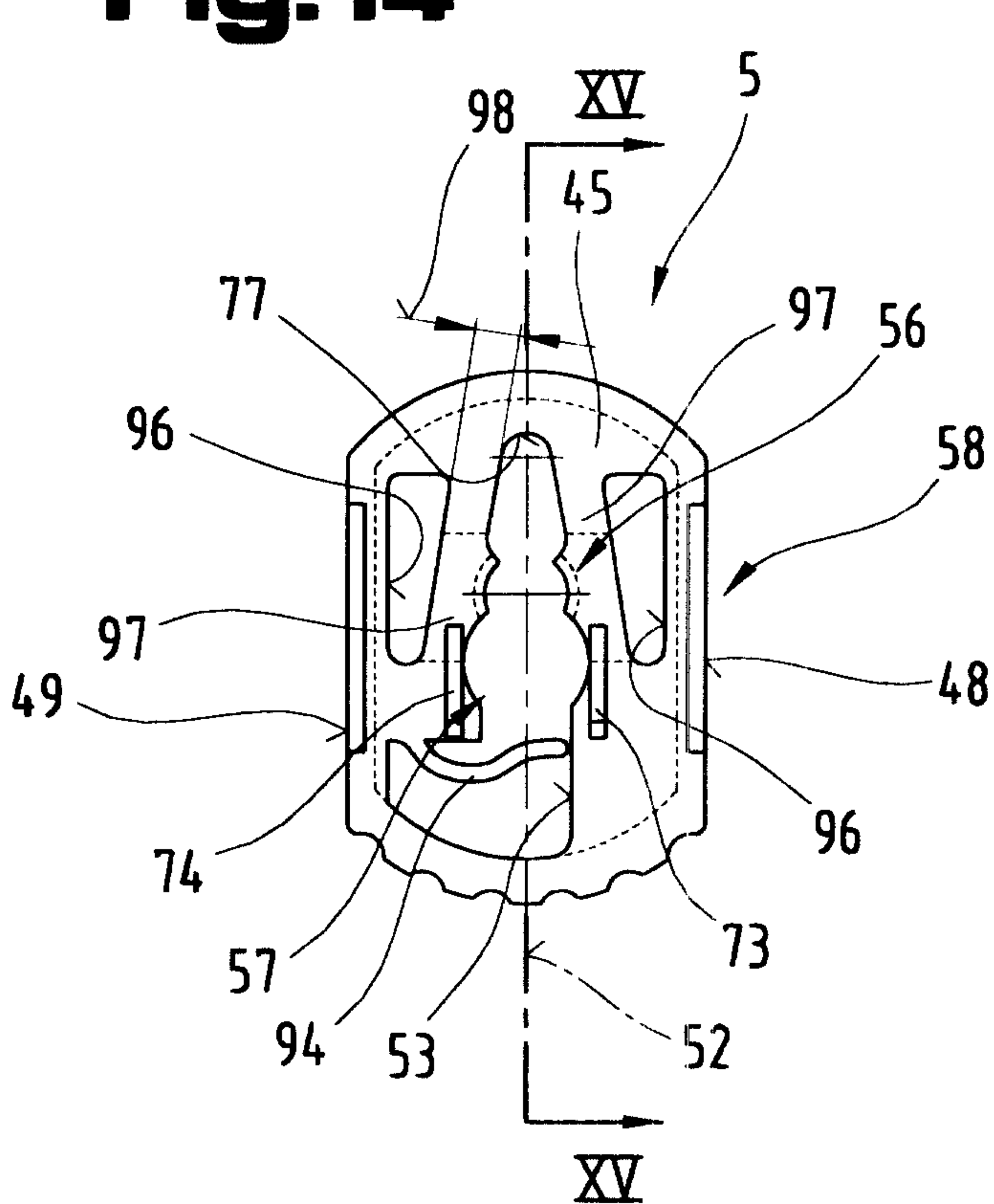

Fig.15

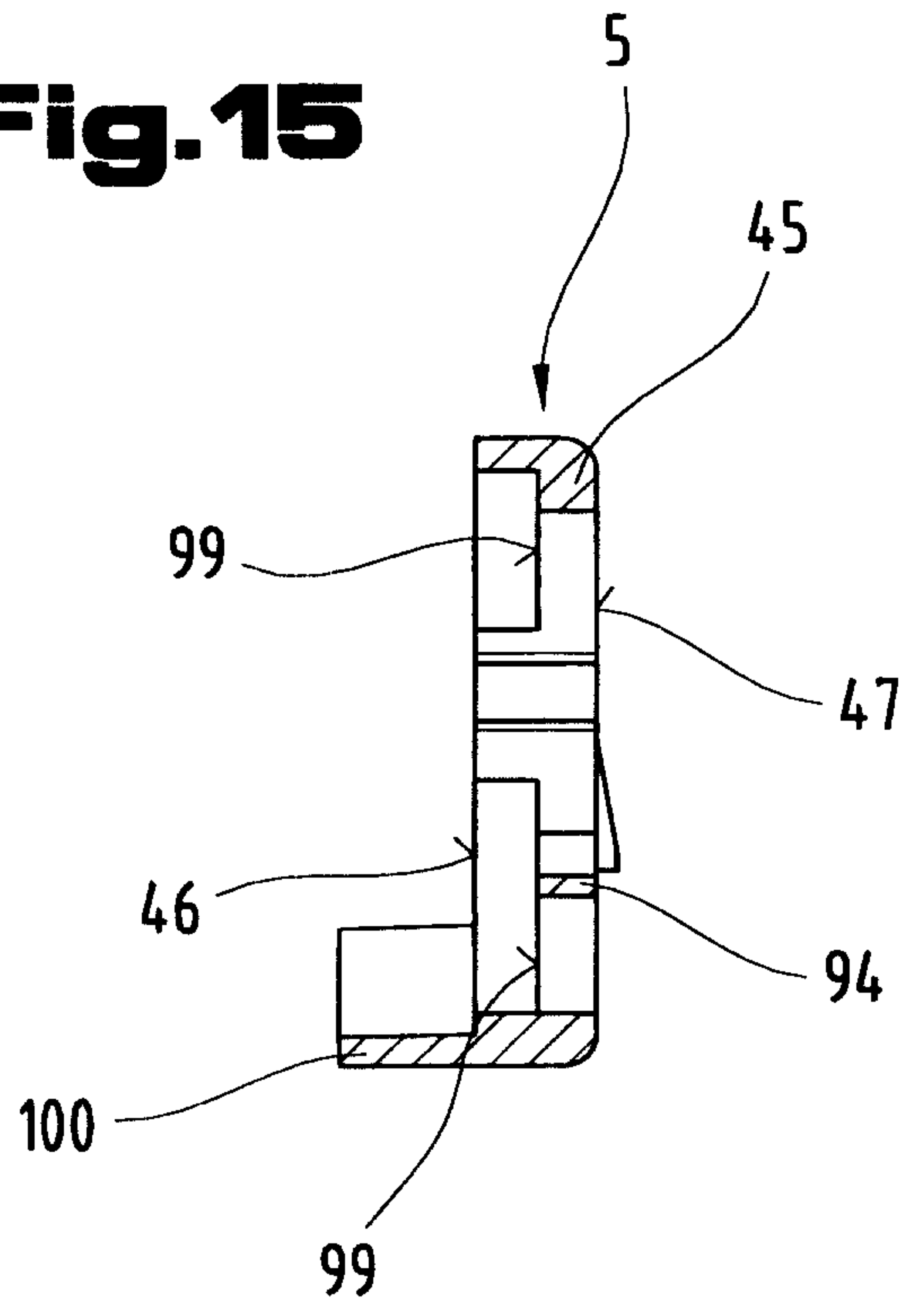

Fig.16

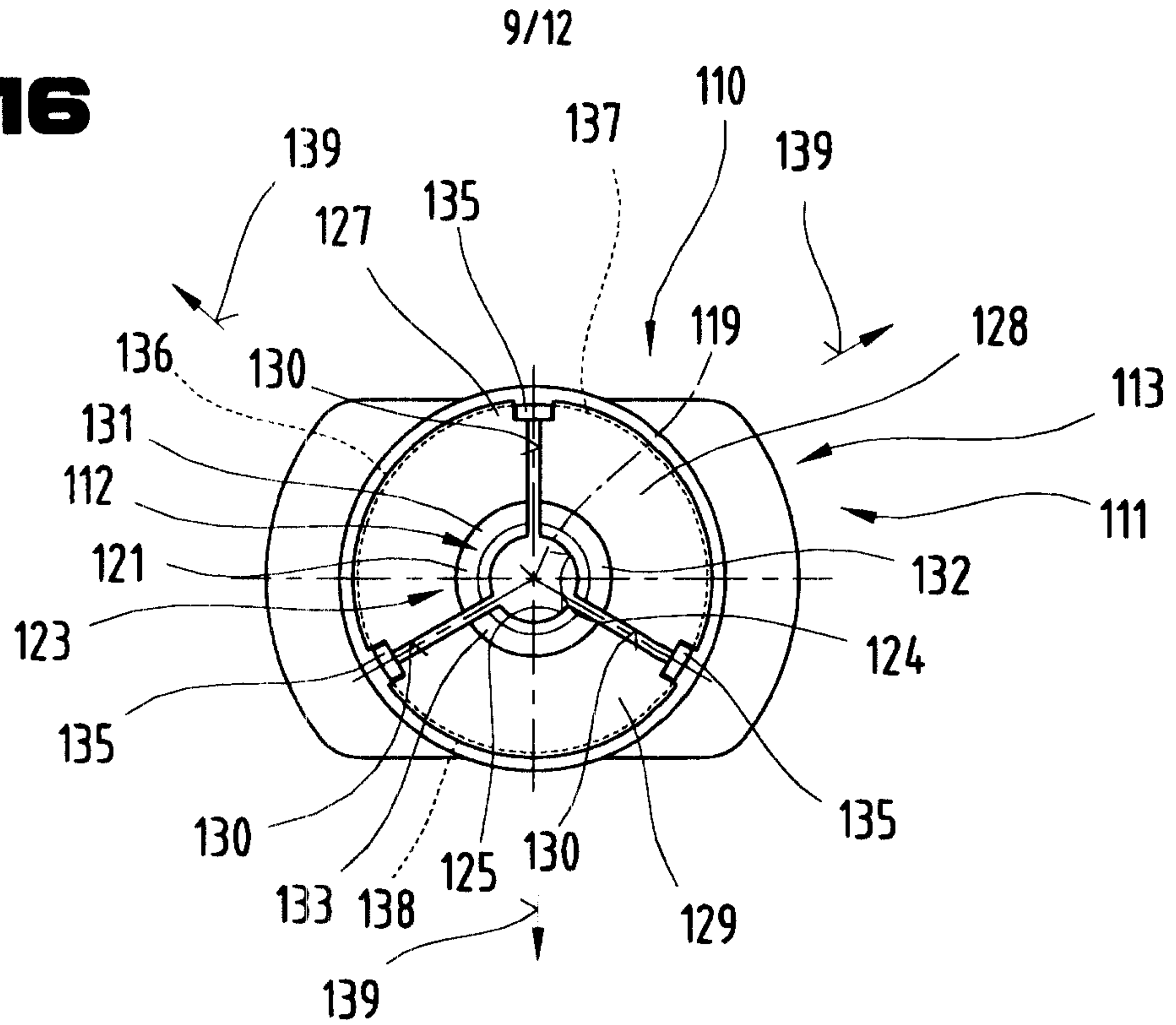

Fig.17

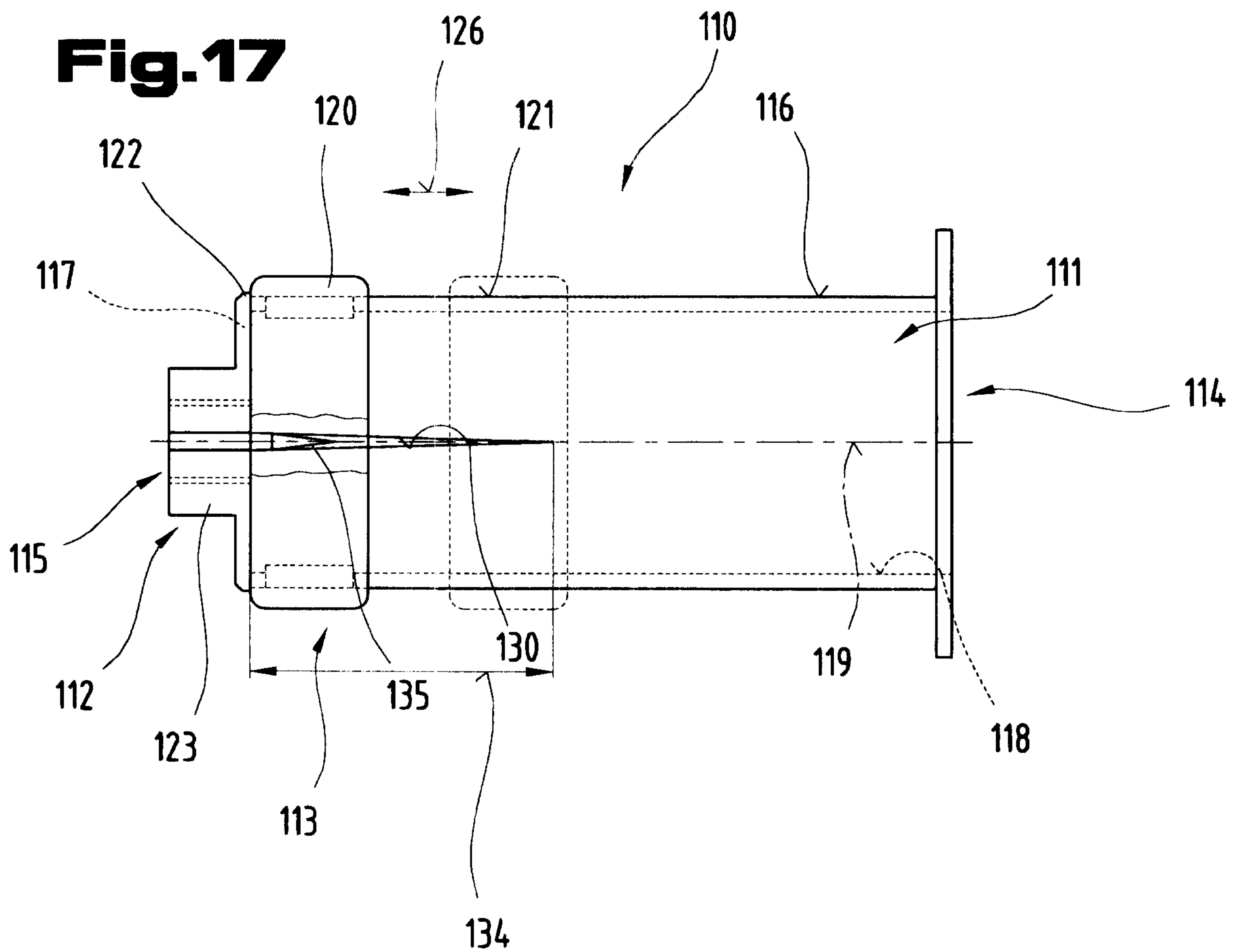

Fig.18

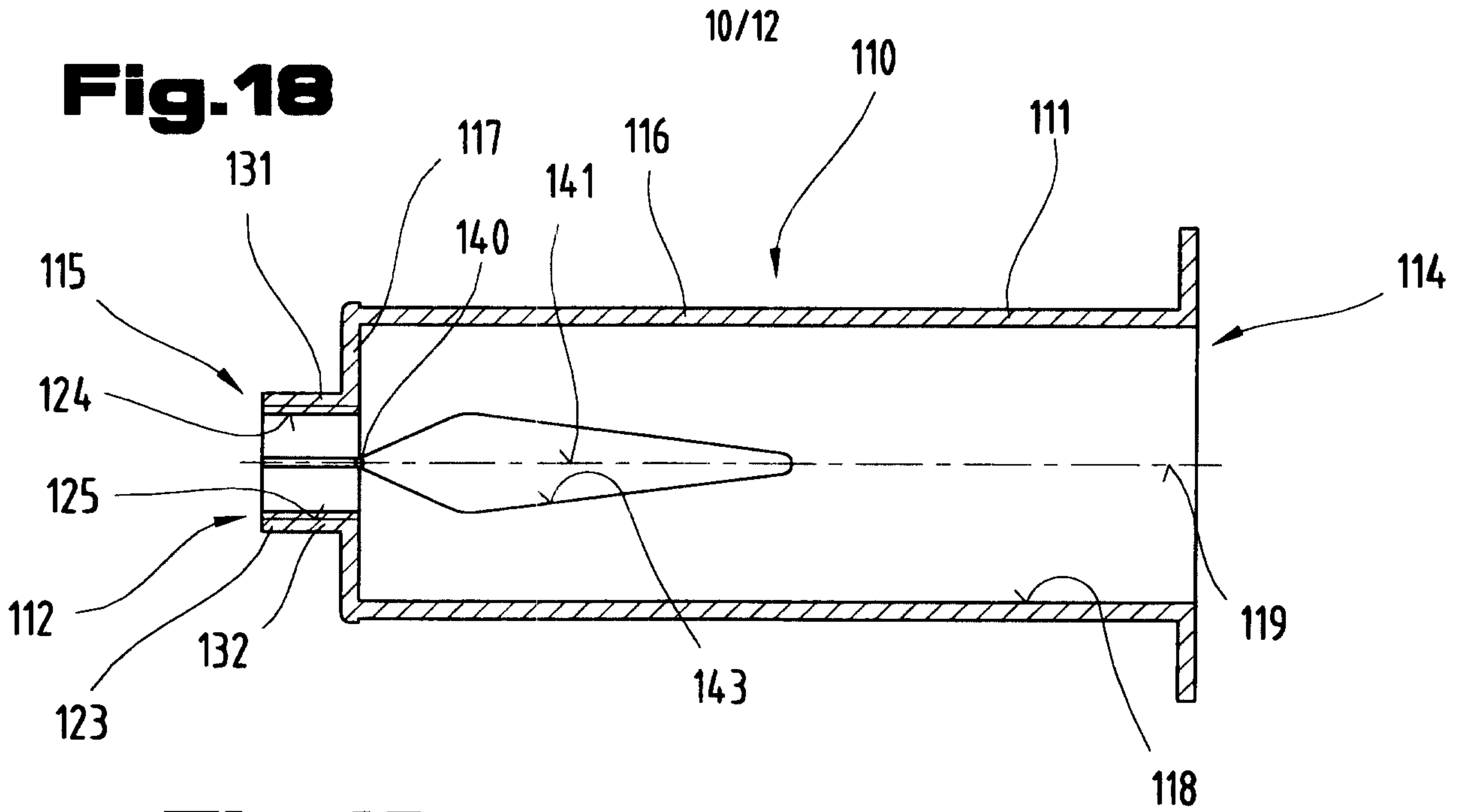

Fig.19

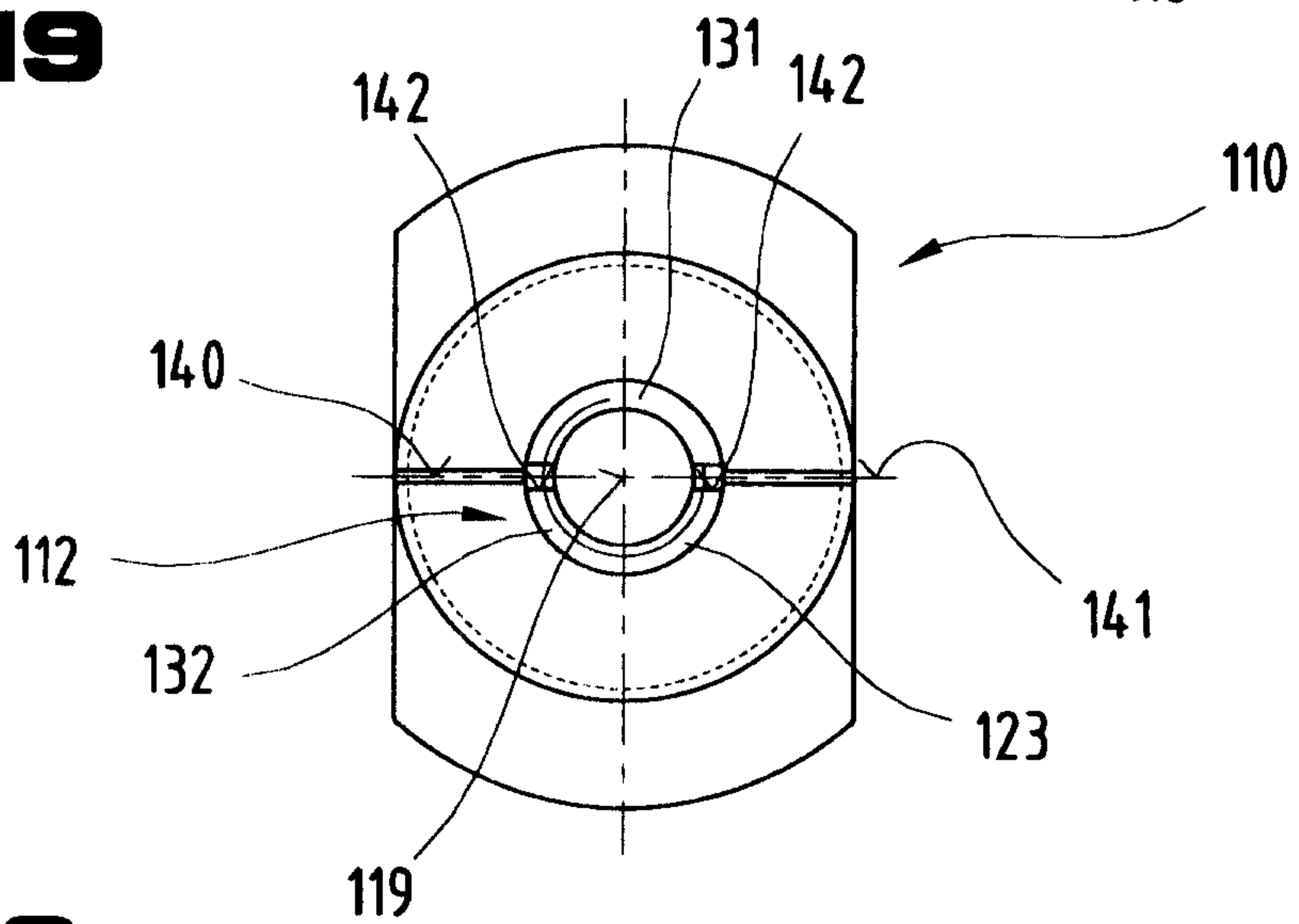

Fig.20

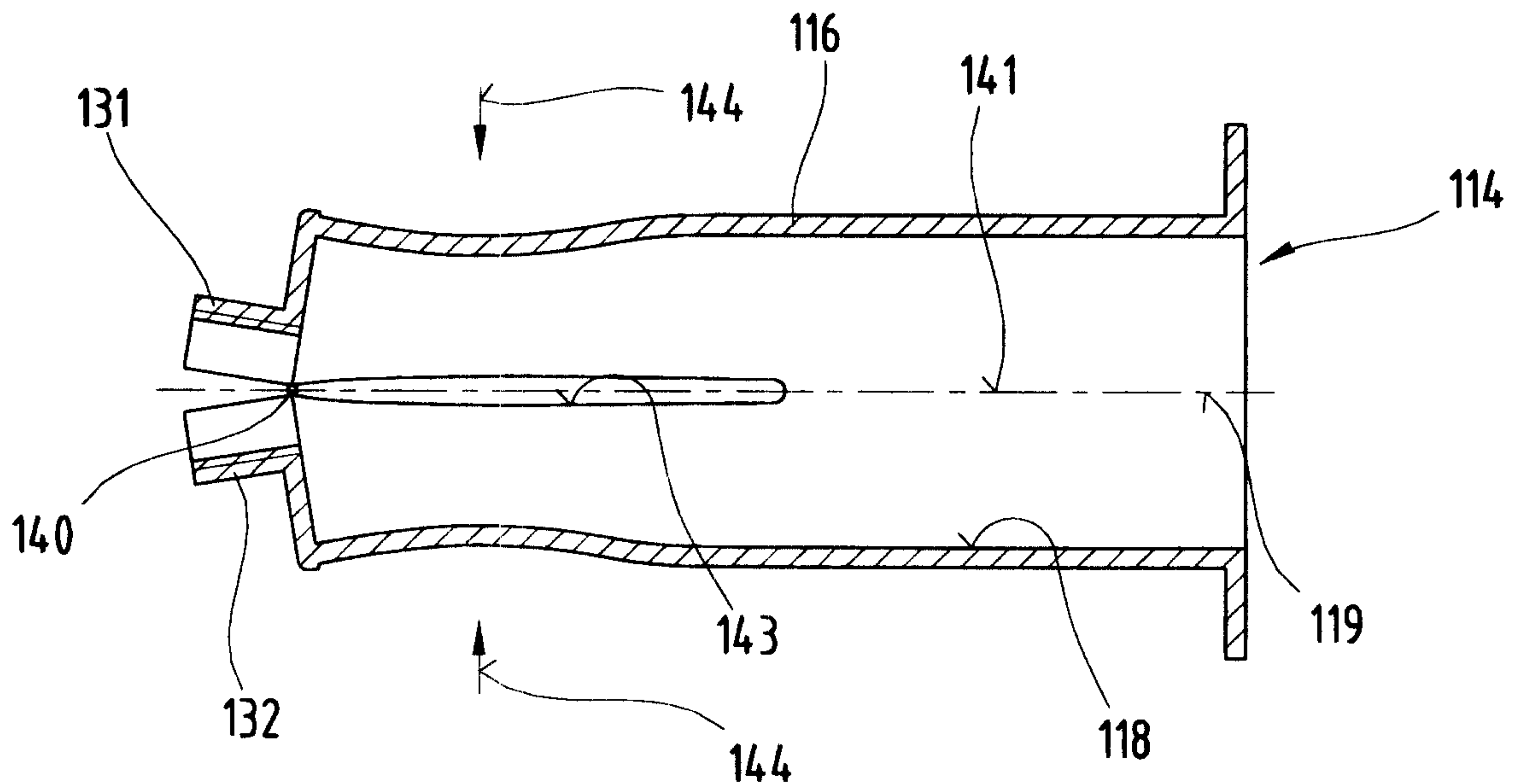

Fig.21

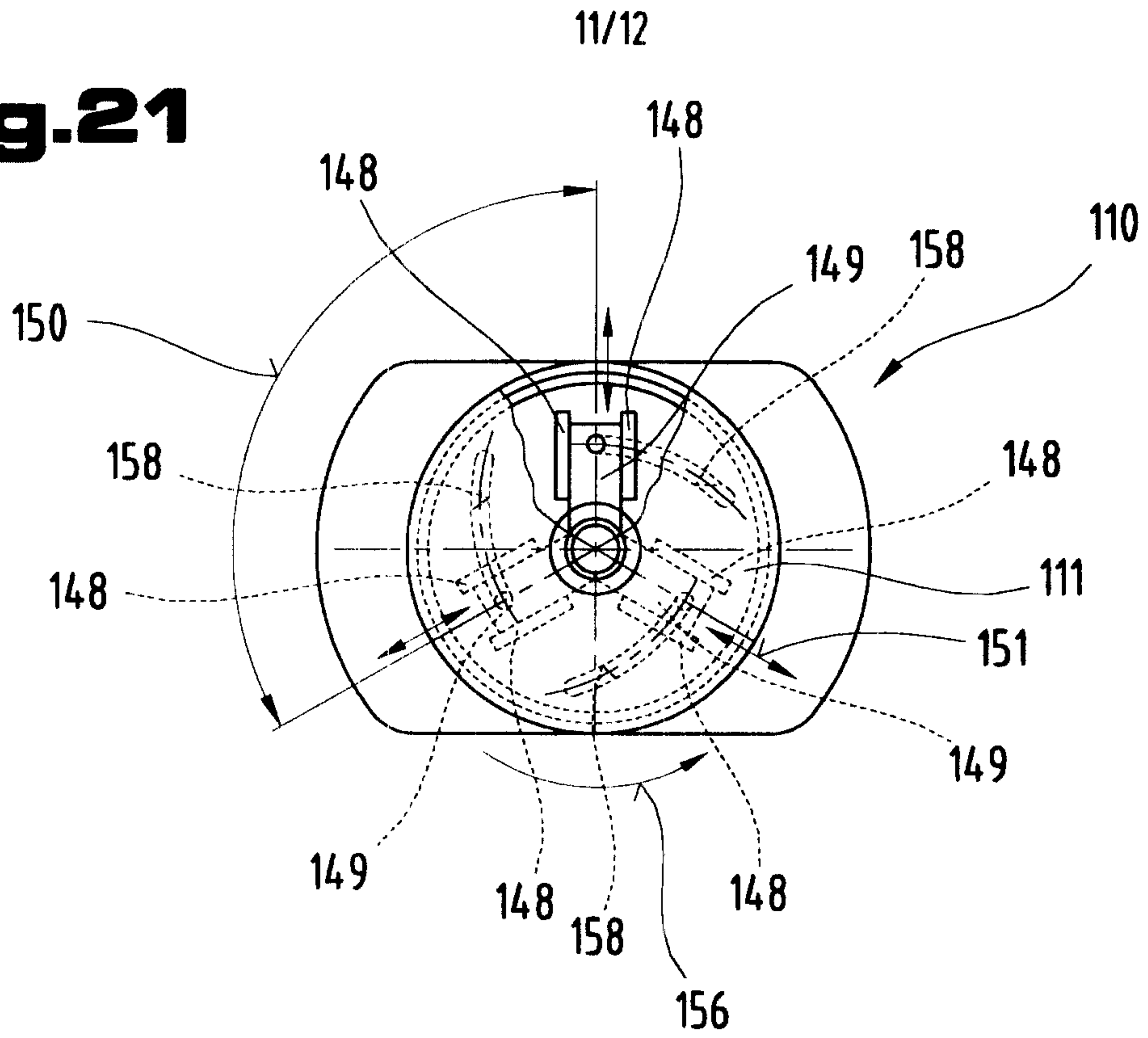

Fig.22

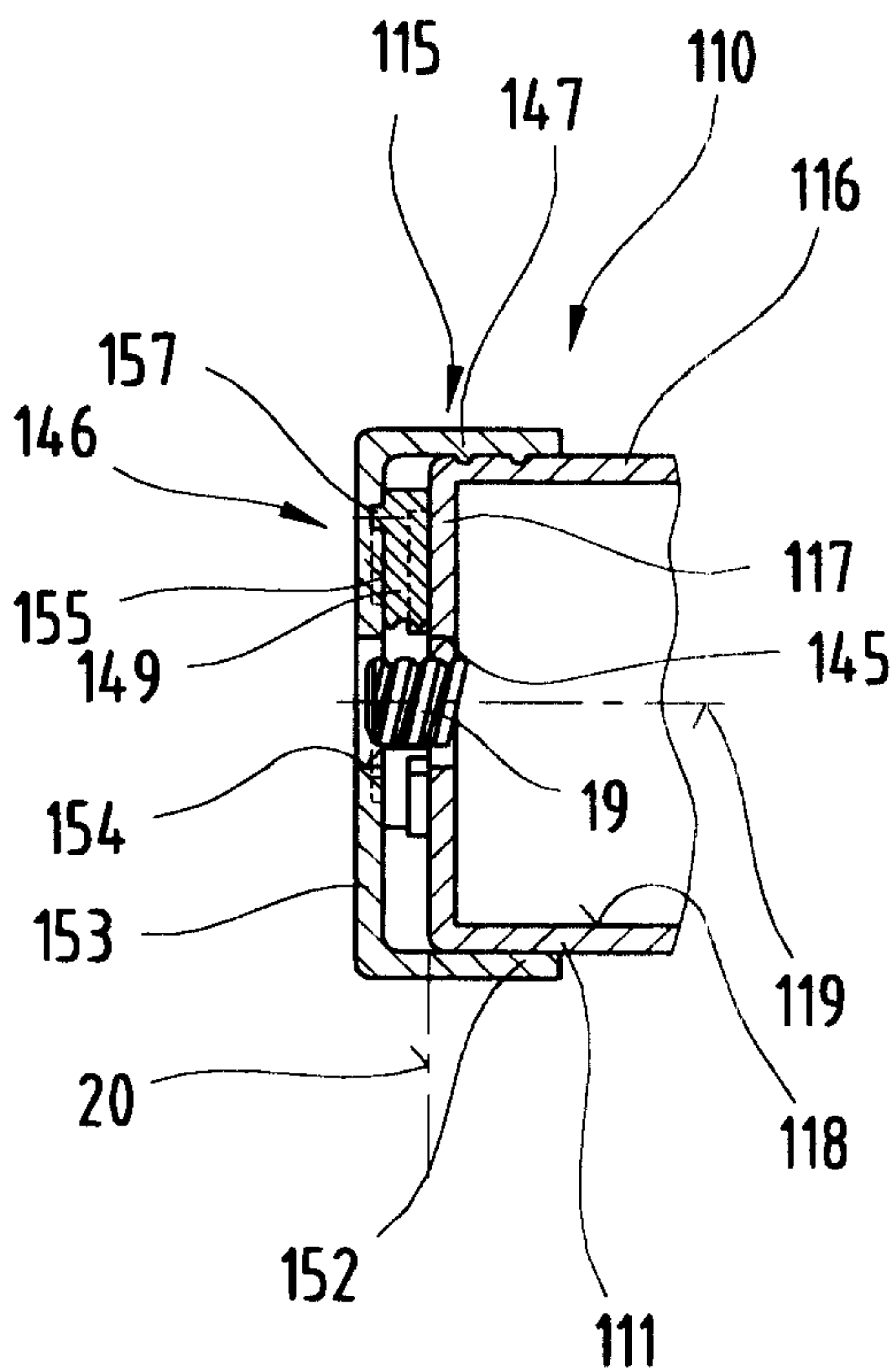

Fig.23

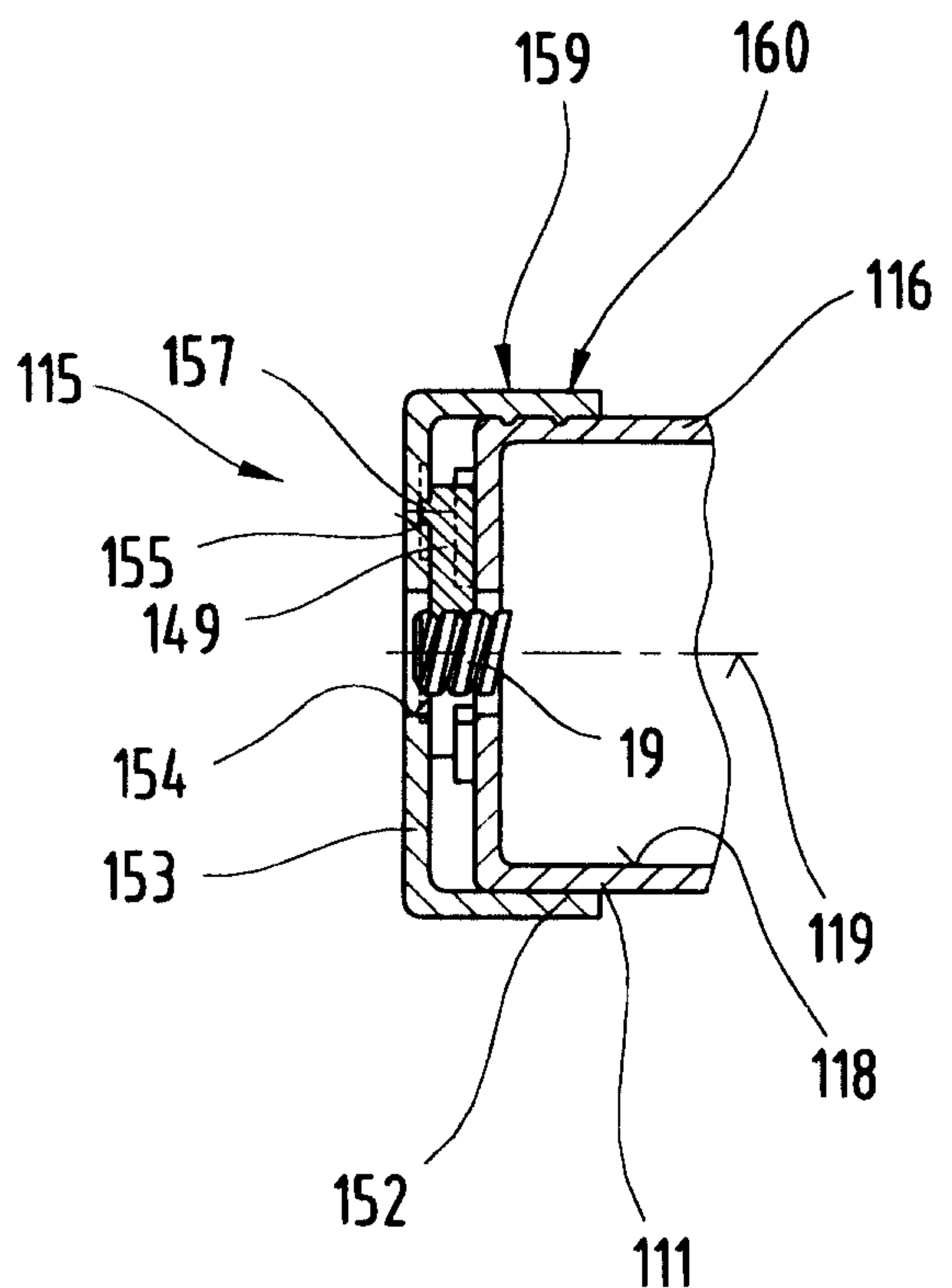

Fig.24

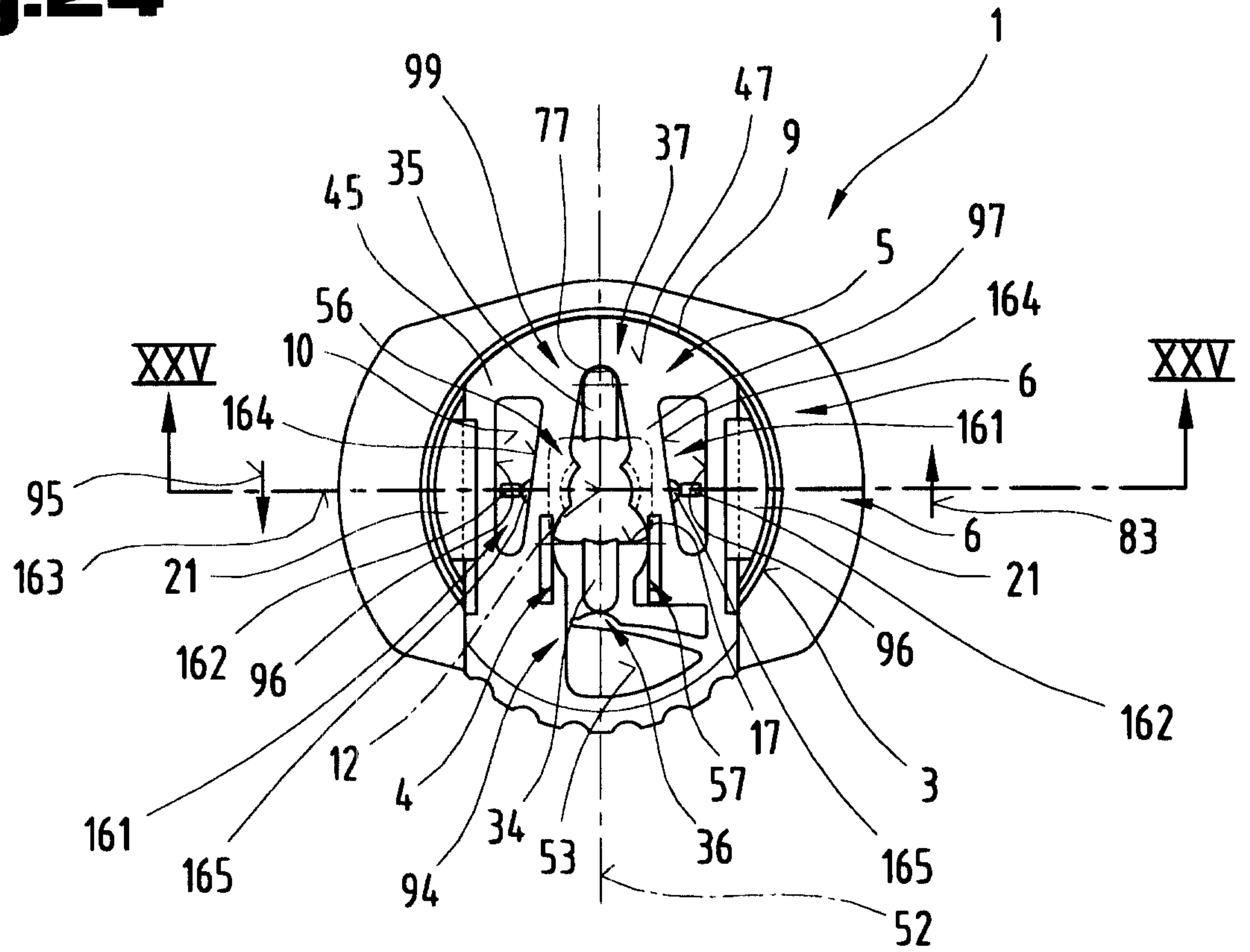

Fig.25

