



US009073094B2

(12) **United States Patent**
Weston et al.

(10) **Patent No.:** **US 9,073,094 B2**
(45) **Date of Patent:** **Jul. 7, 2015**

(54) **METHODS AND APPARATUS TO REDUCE BIOLOGICAL CARRYOVER USING INDUCTION HEATING**

(71) Applicants: **Brad Weston**, Frisco, TX (US); **Jeffrey Mitchell**, Little Elm, TX (US)

(72) Inventors: **Brad Weston**, Frisco, TX (US); **Jeffrey Mitchell**, Little Elm, TX (US)

(73) Assignee: **Abbott Laboratories**, Abbott Park, IL (US)

(*) Notice: Subject to any disclaimer, the term of this patent is extended or adjusted under 35 U.S.C. 154(b) by 38 days.

(21) Appl. No.: **13/721,931**

(22) Filed: **Dec. 20, 2012**

(65) **Prior Publication Data**

US 2013/0167872 A1 Jul. 4, 2013

Related U.S. Application Data

(60) Provisional application No. 61/580,913, filed on Dec. 28, 2011.

(51) **Int. Cl.**

A61L 2/00 (2006.01)
G01N 23/00 (2006.01)
C25B 5/00 (2006.01)
B08B 7/00 (2006.01)
A61L 2/04 (2006.01)
H05B 6/10 (2006.01)

(Continued)

(52) **U.S. Cl.**

CPC ... **B08B 7/00** (2013.01); **A61L 2/04** (2013.01); **A61L 2202/17** (2013.01); **A61L 2202/24** (2013.01); **B01L 2200/141** (2013.01); **H05B 6/108** (2013.01); **B01L 3/021** (2013.01); **B01L 99/00** (2013.01)

(58) **Field of Classification Search**

CPC A61L 2/00; A61L 9/18
USPC 219/600, 764; 250/453.11, 455.11, 250/492.1; 204/156, 157.15; 422/1, 21-22
See application file for complete search history.

(56) **References Cited**

U.S. PATENT DOCUMENTS

4,492,840 A 1/1985 Lex
4,608,472 A * 8/1986 Kato 219/643
5,965,086 A 10/1999 Rose et al.

(Continued)

FOREIGN PATENT DOCUMENTS

DE 2911565 9/1980
EP 0121980 10/1984
WO 9013318 11/1990

OTHER PUBLICATIONS

International Searching Authority, "International Search Report and Written Opinion of the International Searching Authority," issued in connection with application No. PCT/US2012/070807, mailed on Aug. 20, 2013, 20 pages.

(Continued)

Primary Examiner — Monzer R Chorbaji

(74) *Attorney, Agent, or Firm* — Hanley, Flight & Zimmerman LLC

(57) **ABSTRACT**

Methods, systems, apparatus and machine readable media are disclosed to reduce biological carryover. An example method includes generating an alternating electromagnetic field and introducing an aspiration and dispense device into the electromagnetic field. The example method also includes inductively heating the aspiration and dispense device with the electromagnetic field to at least one of denature or deactivate at least one of a protein or a biological entity on a surface of the aspiration and dispense device.

32 Claims, 9 Drawing Sheets

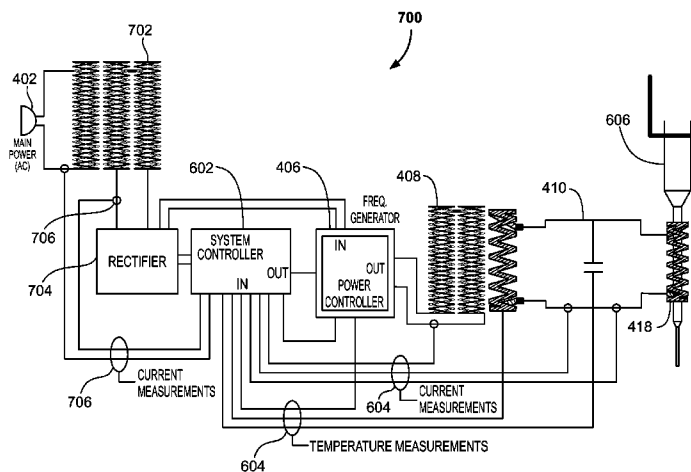

- (51) **Int. Cl.**
B01L 99/00 (2010.01)
B01L 3/02 (2006.01)

- (56) **References Cited**

U.S. PATENT DOCUMENTS

2009/0291018 A1 11/2009 Wallace et al.
2010/0282739 A1 11/2010 Wallace et al.
2011/0211989 A1 9/2011 Hemphill et al.

OTHER PUBLICATIONS

International Bureau, "International Preliminary Report on Patentability," issued in connection with application No. PCT/US2012/070807, mailed on Jul. 10, 2014, 14 pages.

International Searching Authority, "Invitation to Pay Additional Fees and Partial International Search," issued in connection with corresponding PCT application No. PCT/US2012/070807, on Apr. 18, 2013 (8 pages).

* cited by examiner

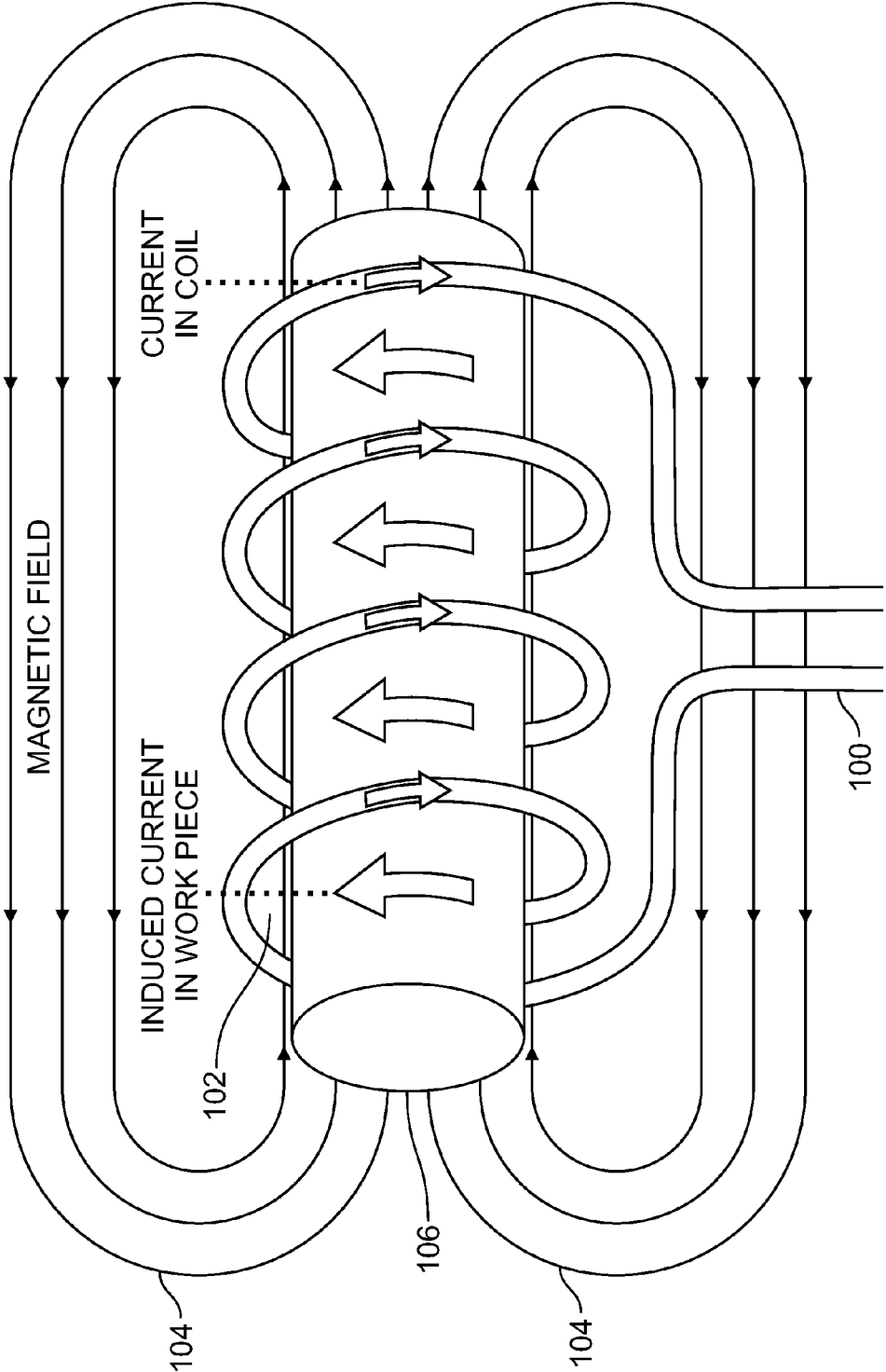

FIG. 1

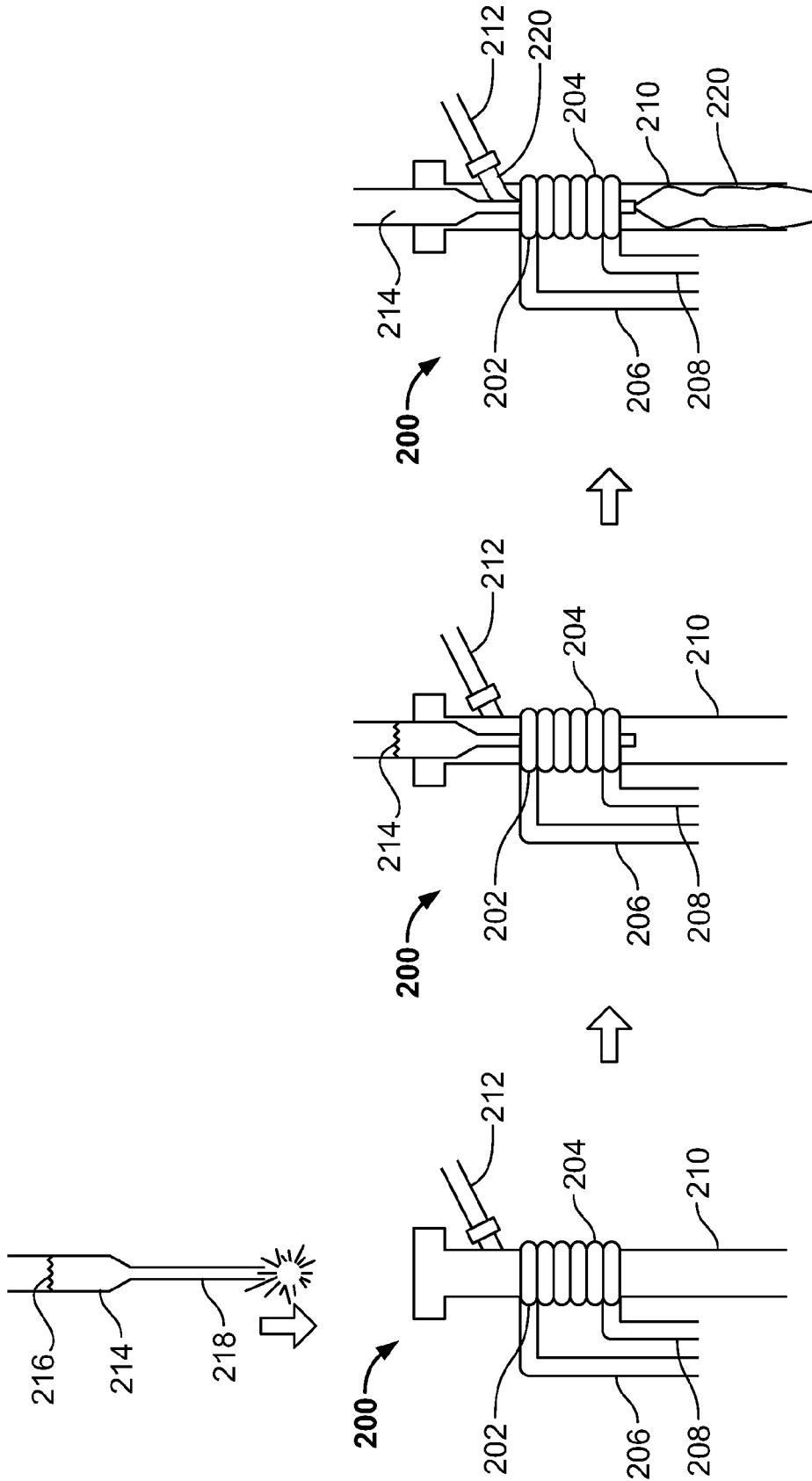

FIG. 2C

FIG. 2B

FIG. 2A

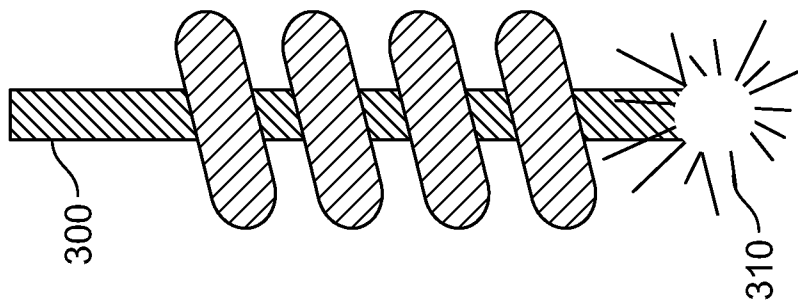

FIG. 3B

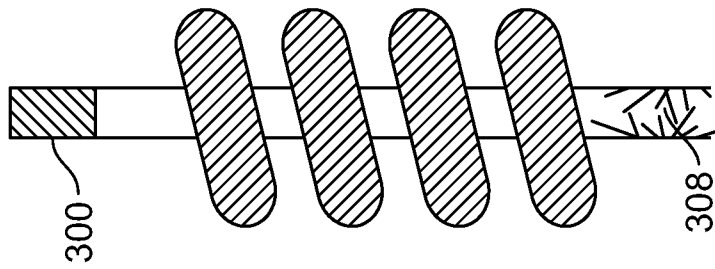

FIG. 3C

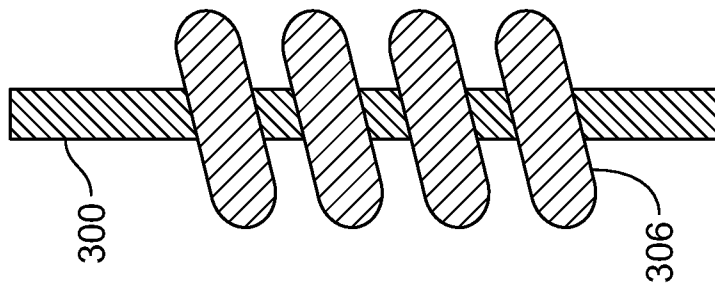

FIG. 3D

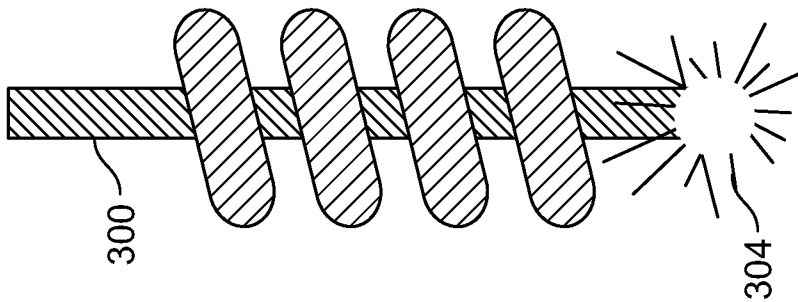

FIG. 3E

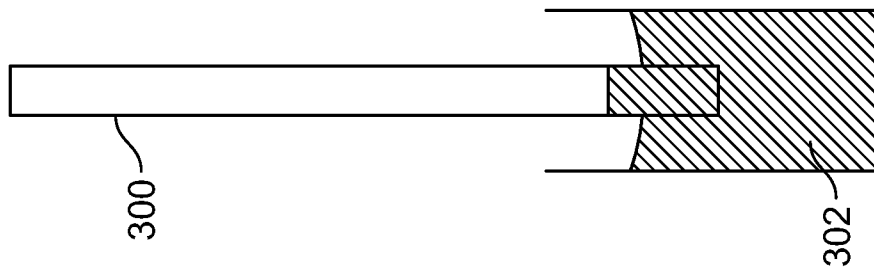

FIG. 3A

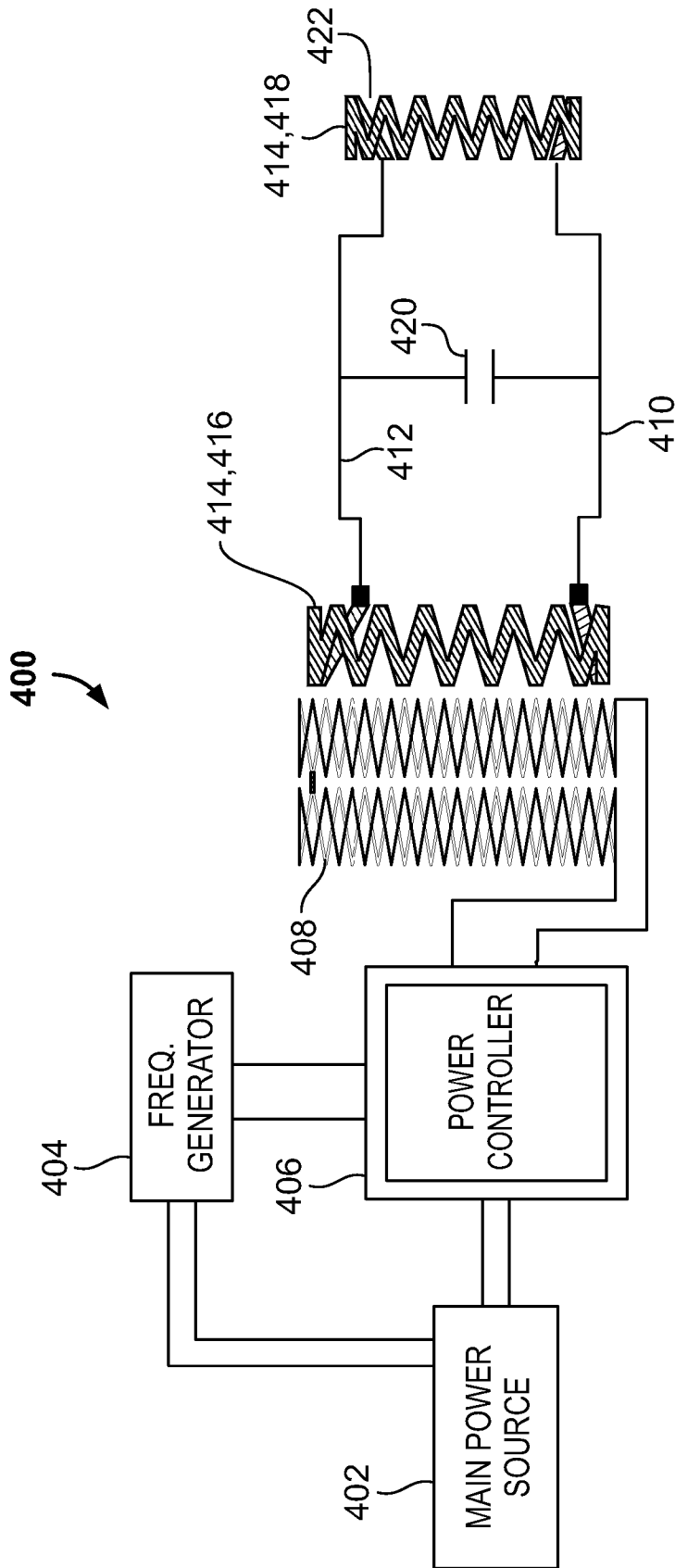

FIG. 4

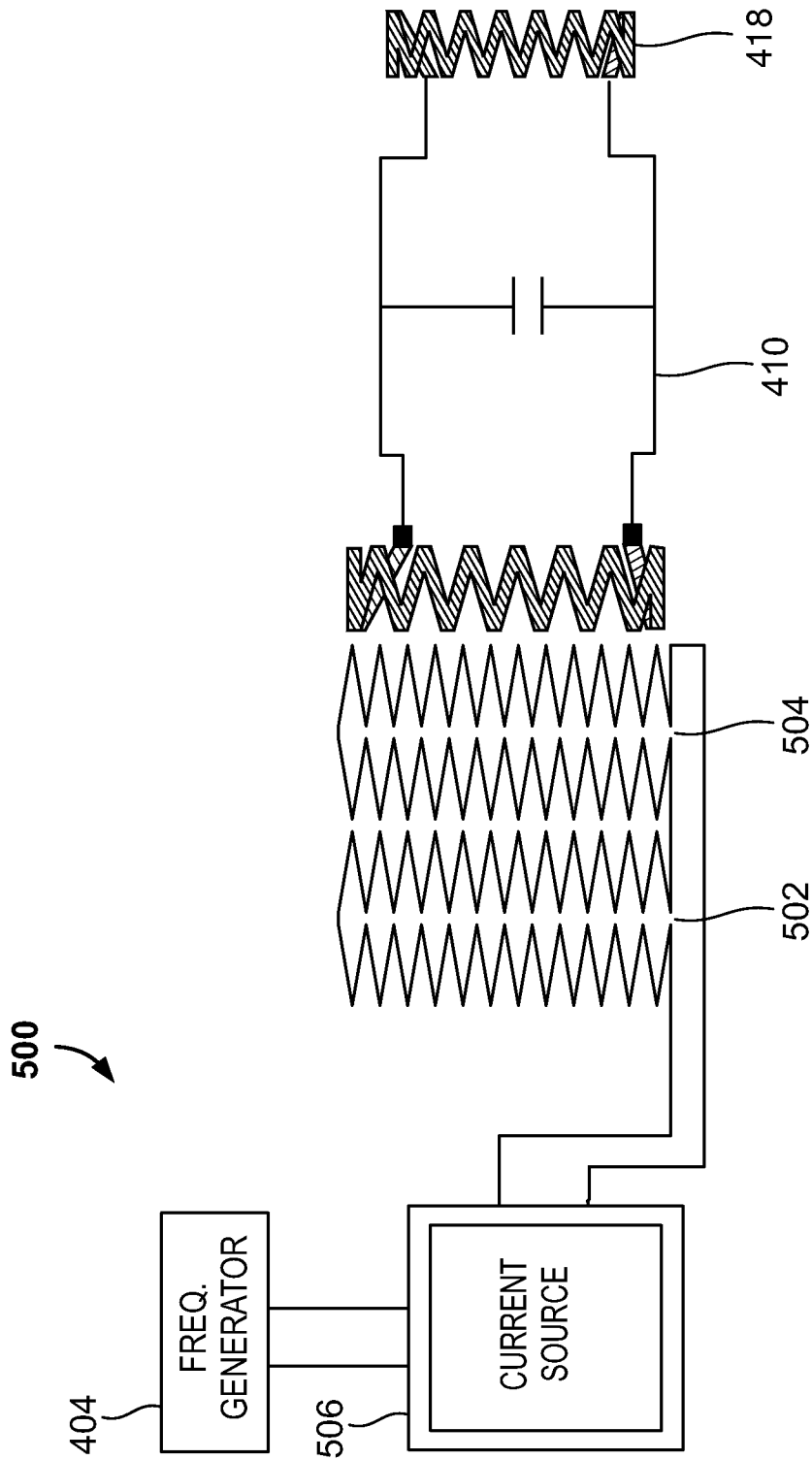

FIG. 5

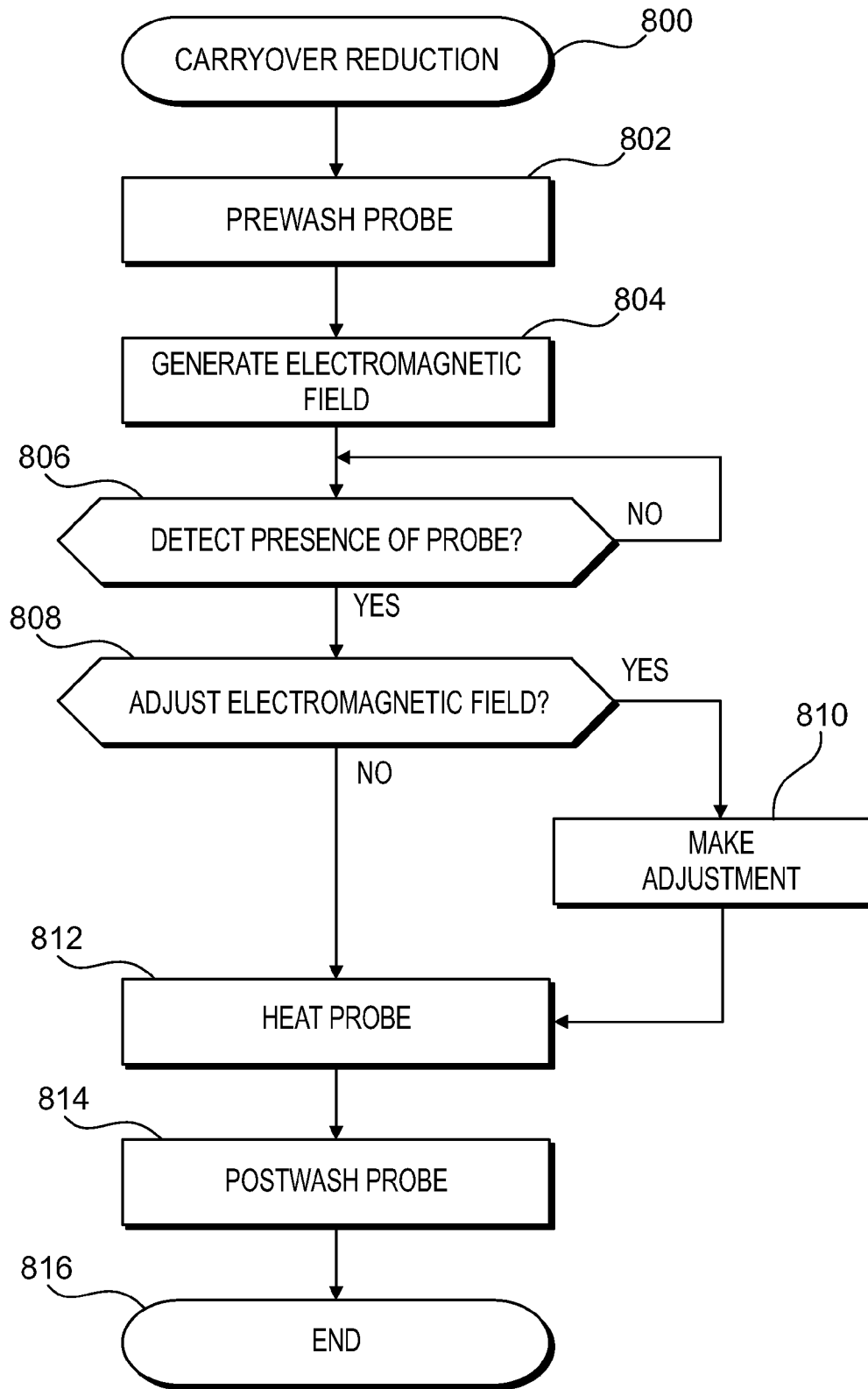

FIG. 8

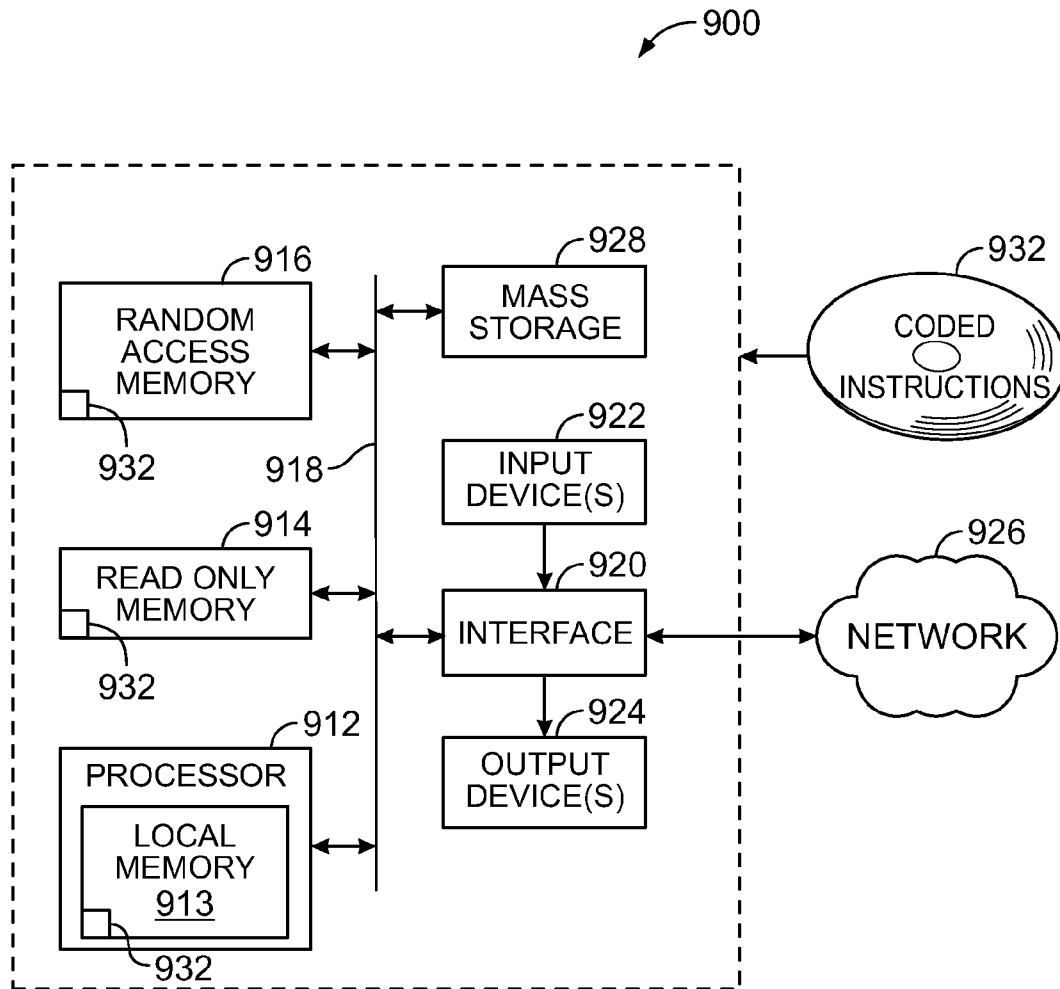

FIG. 9

METHODS AND APPARATUS TO REDUCE BIOLOGICAL CARRYOVER USING INDUCTION HEATING

RELATED APPLICATION

This patent claims priority to U.S. Provisional Patent Application Ser. No. 61/580,913, entitled "Methods and Apparatus to Reduce Biological Carryover Using Induction Heating," which was filed on Dec. 28, 2011, and which is incorporated herein by reference in its entirety.

FIELD OF THE DISCLOSURE

This disclosure relates generally to medical diagnostic equipment and, more particularly, to methods and apparatus to reduce biological carryover using induction heating.

BACKGROUND

Probes are used in medical diagnostic equipment to aspirate and/or dispense samples and reagents into/from sample tubes and reaction vessels. The probability of biological carryover or cross contamination is increased when probes are reused. Some existing methods for preventing cross contamination of proteins require probes to be replaced. Probe replacement produces significant waste and increases operation costs and time.

BRIEF DESCRIPTION OF THE DRAWINGS

FIG. 1 is a schematic illustration of electromagnetic induction.

FIGS. 2A-C illustrate an example aspiration and dispense device being inductively heated and washed.

FIGS. 3A-E illustrate another example aspiration and dispense device being inductively heated and washed.

FIG. 4 is a schematic illustration of an example architecture for an electromagnetic field generator.

FIG. 5 is a schematic illustration of another example architecture for an electromagnetic field generator.

FIG. 6 is a schematic illustration of another example architecture for an electromagnetic field generator.

FIG. 7 is a schematic illustration of yet another example architecture for an electromagnetic field generator.

FIG. 8 is a flow chart representative of an example process that may be performed to implement example systems disclosed herein.

FIG. 9 illustrates an example processor platform that may be used to implement any or all of the example methods, systems and/or apparatus disclosed herein.

DETAILED DESCRIPTION

Automated medical diagnostic equipment and automated pipette systems use one or more aspiration and/or dispense devices such as, for example pipettes or probes, to aspirate and/or dispense samples such as biological samples and/or reagents into and/or from reaction vessels such as, for example, one or more well(s) on a multi-well plate. The exterior and interior surfaces of the aspiration and/or dispense device come into contact with the sample and/or reagent and a portion of the sample and/or reagent may remain on the exterior and/or interior surface after the sample and/or reagent has been dispensed. Subsequent use of the aspiration and/or dispense device could result in sample carryover or reagent carryover. Such carryover is the transfer of the

residual sample and/or reagent to another sample and/or reagent, which contaminates the sample and/or reagent and may lead to an inaccurate analysis or diagnosis.

Some systems include a wash station to wash the surfaces of an aspiration and/or dispense device. However, wash stations require volumes of wash solution. In addition, any defects, scratches, indentations or other imperfections or irregularities of the surfaces of the aspiration and/or dispense device may harbor biological samples and/or reagents such that the aspiration and/or dispense device is not sufficiently clean after a washing cycle.

In other systems, electrostatic induction is used to heat an aspiration and/or dispense device to a level of sterilization. Such systems create a non-alternating electrical potential (e.g., a voltage) across the aspiration and/or dispense device and create heat via electrical resistance. These systems require a relatively high voltage and current and, therefore, have an increased risk of electrical shorting. In addition, these systems typically heat the entire aspiration and/or dispense device and, therefore, localized heating and cleaning of only a contaminated region is not possible. Furthermore, the current flows in a non-uniform manner through the aspiration and/or dispense device along the paths of least resistance. Areas of the surface of the aspiration and/or dispense device that include defects, scratches, dents or other irregularities have higher resistance. Therefore, these areas, which are particularly sensitive to biological buildup, experience less current flow and, therefore, less heating than other areas of the aspiration and/or dispense device. Thus, devices cleaned through electrostatic induction may not be sufficiently free from biological carryover.

The example systems, methods and apparatus disclosed herein use electromagnetic induction heating to clean aspiration and/or dispense devices. In the examples disclosed herein, reactive proteins and/or other biological entities on the surfaces of the aspiration and/or dispense device are deactivated and/or denatured using heat that is generated via electromagnetic induction. The deactivation or denaturing of the biological substances provides protection against biological carryover by reducing or eliminating cross contamination between discrete reactions.

The inductive heating is achieved through a metallic coil, or any other shape of continuous electrically conducting media in which the size and shape and is designed to provide a desired heating pattern, through which a high frequency, high current electrical signal flows to induce an opposing current in a target object (e.g., the aspiration and/or dispense device to be cleaned) per Faraday's law of induction. The opposing current heats the aspiration and/or dispense device and the residual proteins and/or other biological matter fixed thereto. The proteins and/or other biological matter are heated above a critical temperature to change the manner in which these materials react and bind to other objects or substances, which reduces the chance for unintended reactions. The examples disclosed herein reduce or eliminate the likelihood of contamination between discrete fluid movements or reactions, without the need for extensive washing, expensive coatings or single use probes.

An example method disclosed herein includes generating an alternating electromagnetic field and introducing an aspiration and/or dispense device into the electromagnetic field. The example method also includes inductively heating the aspiration and/or dispense device with the electromagnetic field to at least one of denature or deactivate at least one of a protein or a biological entity on a surface of the aspiration and/or dispense device.

Some examples disclosed herein include washing the aspiration and/or dispense device prior to introducing the aspiration and/or dispense device into the electromagnetic field. In addition, some examples include washing the aspiration and/or dispense device after inductively heating the aspiration and/or dispense device with the electromagnetic field. In some examples, the washing comprises washing with a cooling wash to lower a temperature of the aspiration and/or dispense device. Also, some examples include washing the aspiration and dispense device during inductively heating the aspiration and dispense device with the electromagnetic field.

Some examples disclosed herein include generating the electromagnetic field by flowing a current through an electrically conducting media, using a frequency that is based on a diameter of the aspiration and/or dispense device. Also, some examples disclosed herein include generating the electromagnetic field by flowing a current through an electrically conducting media, using a frequency that is based on a thickness of a skin or wall of the aspiration and/or dispense device. In some examples, the electrically conducting media comprises a coil. In other examples, the electrically conducting media comprises any other shape of continuous electrically conducting media in which the size and shape and is designed to provide a desired heating pattern.

In some of the disclosed examples, the aspiration and/or dispense device is raised and/or lowered through the electromagnetic field to inductively heat the aspiration and/or dispense device along a length of the aspiration and/or dispense device. Also, in some examples, the thickness of the skin varies along the length of the aspiration and/or dispense device, and the frequency is adjusted as the aspiration and/or dispense device is raised or lowered.

In some examples disclosed herein, only a portion of the aspiration and/or dispense device is inductively heated. In other examples, inductively heating the aspiration and/or dispense device with the electromagnetic field includes heating the aspiration and/or dispense device without directly contacting the aspiration and dispense device via an electrical and/or an electrostatic connection.

In some examples, generating the alternating electromagnetic field comprises using a standard electrical wall outlet. Also, some of the disclosed examples include disposing a wash cup between the aspiration and/or dispense device and an electrically conducting media such as, for example, a coil used to create the electromagnetic field and preventing direct contact between the aspiration and dispense device and the electrically conducting media with the wash cup.

An example system disclosed herein includes an electromagnetic field generator and an aspiration and/or dispense device to be introduced into the electromagnetic field and to be inductively heated with the electromagnetic field. The example system also includes a wash cup to interpose the electromagnetic field generator and the aspiration and dispense device to prevent direct contact therebetween. In some example systems, the aspiration and dispense device lacks an electrical connector coupled to a surface of the aspiration and dispense device, and the aspiration and dispense device is electrically isolated.

Some example systems also include a washer to wash the aspiration and/or dispense device prior to introducing the aspiration and/or dispense device into the electromagnetic field and/or after inductively heating the aspiration and/or dispense device with the electromagnetic field. In some examples, the washer is to wash with a cooling wash to lower a temperature of the aspiration and/or dispense device.

In some examples, the electromagnetic field generator comprises a frequency generator and a coil, and the frequency

generator is to generate a variable frequency current to flow through the coil. The frequency is based on a diameter of the aspiration and/or dispense device. Also, in some examples, the electromagnetic field generator comprises a frequency generator and an electrically conducting media (e.g., a coil or any other shape of continuous electrically conducting media in which the size and shape and is designed to provide a desired heating pattern), and the frequency generator to generate a variable frequency current to flow through the electrically conducting media. The frequency is based on a thickness of a skin of the aspiration and/or dispense device.

Some example systems include an arm to raise or lower the aspiration and dispense device through the electromagnetic field to inductively heat the aspiration and/or dispense device along a length of the aspiration and dispense device. Some example systems include a frequency generator to adjust the frequency as the aspiration and/or dispense device is raised or lowered. Such frequency may be adjusted where the thickness of the skin varies along the length of the aspiration and/or dispense device.

In some examples, the electromagnetic field is to inductively heat only a portion of the aspiration and/or dispense device. In some examples, the aspiration and/or dispense device is to be heated without directly contacting an electrical connection. In some example systems disclosed herein, a surface of the aspiration and/or dispense device is heated to denature or deactivate at least one of a protein or a biological entity on the surface.

Some example systems include a controller and a feedback loop. The feedback loop is to provide data to the controller comprising one or more of frequency, an impedance, a presence of the aspiration and dispense device in the electromagnetic field, a voltage reading or a current reading and the controller to change the frequency to change a strength of the electromagnetic field to vary a heating temperature of the aspiration and/or dispense device based on the data.

Also disclosed are example tangible machine readable media having instructions stored thereon which, when executed, cause a machine to generate an alternating electromagnetic field and introduce an aspiration and/or dispense device into the electromagnetic field. The example instructions further cause the machine to inductively heat the aspiration and/or dispense device with the electromagnetic field to denature and/or deactivate at least one of a protein or a biological entity on a surface of the aspiration and/or dispense device.

Turning now to the figures, FIG. 1 shows a schematic illustration of electromagnetic induction. As shown in FIG. 1, a coil 100 includes a high frequency alternating (AC) current flowing in a first direction as represented by the white arrows. The interior of the loops of the coil 100 form a work space 102. When the current is flowing through the coil 100, an alternating magnetic field 104 extends through the workspace 102 and around the coil 100. A work piece 106, which may represent for example, a portion of a probe or other aspiration and/or dispense device, may be inserted into the workspace 102. The alternating magnetic field 104 produces eddy currents in the work piece 106. The eddy currents flow in a direction opposite the alternating current in the coil 100, as represented by the larger arrows. Magnetic hysteresis losses and Ohmic heating raise the temperature of the work piece 106. The heat changes the binding properties of any proteins or other biological entities that may be present on surfaces of the work piece 106 to denature and deactivate such proteins and biological entities. The foregoing process works with ferrous metals, non-magnetic metals, and/or other conductive materials.

FIGS. 2A-C illustrate a portion of an example system **200** to reduce biological carryover during three operations. The example system **200** includes an electromagnetic field generator **202** which, in this example, includes a metal coil **204** such as, for example, a copper coil. The coil **204** has a first lead **206** and a second lead **208** to electrically couple the coil **204** to a power source such as, for example, an AC power source. The interior of the coil **204** forms a workspace into which one or more work piece(s) may be disposed, as described below. As described in connection with FIG. 1, when an electrical current flows through the coil **204**, a magnetic field is created and an opposing current is induced in the work piece(s).

The example system **200** also includes an example wash cup **210**. In this example, the wash cup **210** is an open-ended splash container that may be made of, for example, glass, ceramic, plastic, electrically insulating and/or any other suitable non-metallic material. The wash cup **210** includes an inlet **212** to enable the introduction of wash fluid into the wash cup **210**. The system **200** also includes a pipettor probe or other aspiration and/or dispense device **214**. In this example, the aspiration and/or dispense device **214** is a metal probe such as, for example, stainless steel. In FIG. 2A, the aspiration and/or dispense device **214** is above or outside of the coil **204**. The aspiration and/or dispense device **214** includes a liquid **216**, which may be, for example, a sample, a reagent a wash solution or any combination thereof. In this example, an exterior surface of the aspiration and/or dispense device **214** is contaminated with protein or biological matter **218**. The protein or biological matter **218** may be adhered to the exterior surface in a scratch or other surface anomaly and/or due to hydrophobicity, ionic charges, electrostatic charges, protein adsorption, and/or surface energy.

In FIG. 2B, the aspiration and/or dispense device **214** is lowered into the wash cup **210**, and the coil **204** is powered to generate an alternating electromagnetic field. In this example, the wash cup **210** interposes the aspiration and/or dispense device **214** to prevent direct contact therebetween. Thus, the aspiration and/or dispense device **214** is remotely inductively heated preventing biological contamination with the coil **204**. An advantage to this structure is that a standard aspiration and/or dispense device (e.g., probe) can be used. There is no need for an electrical connector fitted to the aspiration and/or dispense device. Thus, the aspiration and/or dispense device is electrically isolated. The electrical isolation reduces the chances of an operator experiencing an electrical shock because of accidental (or intentional) contact with the aspiration and/or dispense device. The current generated in the aspiration and/or dispense device occurs only where there is a strong alternating magnetic field, and that current is generated only in the material of the aspiration and/or dispense device. More specifically, an operator does not provide a grounding path for the current being generated in the work piece (e.g., the aspiration and/or dispense device) because the current is only being generated within the immediate magnetic field, and the current is in self-contained and isolated loops.

The electrical current in the coil **204** creates a magnetic field that induces an electrical current in the aspiration and/or dispense device **214**. The electrical current in the aspiration and/or dispense device **214** generates heat such that the aspiration and/or dispense device **214** is inductively heated. In this example, the aspiration and/or dispense device **214** may be heated to a temperature of, for example 300° C., and any residual proteins and/or biological matter are coagulated, denatured and deactivated. Temperatures as low as, for example, 43° C. denature some proteins. Most proteins incin-

erate by 300° C. The temperature may be raised much higher, including, for example, 760° C. If there are scratches or other surface anomalies on the aspiration and/or dispense device **214**, the current is diverted around the root of the imperfection, which increases the local current density and therefore the local heat generation and ensures cleaning of these areas. When there is a crack, scratch, or imperfection, the current is concentrated and directed under the crack, scratch, or imperfection such that the base experiences increased heating, which is where contamination may accumulate. The liquid **216** may be dispensed from the aspiration and/or dispense device **214** prior to or during this operation.

In addition, in the disclosed example, the electromagnetic field inductively heats only a portion of the aspiration and/or dispense device **214** to increase target cleaning of the aspiration and/or dispense device **214** and eliminates the need to heat the entire aspiration and/or dispense device **214**. For example, only the portion of the aspiration and/or dispense device **214** located within the work space defined by the coil **204** is heated. Some example systems include an arm (see FIG. 6) to raise or lower the aspiration and/or dispense device **214** through the electromagnetic field to inductively heat different portions of the aspiration and/or dispense device **214** along a length of the aspiration and/or dispense device **214**.

Also, as described in greater detail below, in some examples, the current flowing through the coil **204** is varied depending on a diameter of the portion of the aspiration and/or dispense device **214** in the work space and/or depending on a thickness of a skin of the portion of the aspiration and/or dispense device **214** in the work space. In some examples, the thickness of the skin and/or the diameter varies along the length of the aspiration and/or dispense device **214** and a frequency of the current is adjusted as the aspiration and/or dispense device **214** is raised or lowered.

In some examples, there is a pre-treatment procedure such as, for example, a prewash to clean the surfaces of the aspiration and/or dispense device **214** prior to the entry of the aspiration and/or dispense device **214** into the work space of the coil **204**. Also, in some examples, there is a post-treatment procedure such as, for example, a postwash as shown in FIG. 2C. In this example, the power to the coil **204** is deactivated and an active probe wash flushes wash fluid **220** through the inlet **212** to wash the outer surface of the aspiration and/or dispense device **214** to remove residue proteins and/or other biological materials. The wash fluid **220** has a relatively cooler temperature to reduce the temperature of the aspiration and/or dispense device **214** to return the temperature of the aspiration and/or dispense device to, for example, ambient temperature. The aspiration and/or dispense device **214** is ready to be reused following the operation of FIG. 2B and/or FIG. 2C.

FIGS. 3A-E illustrate another example aspiration and/or dispense device **300** being inductively heated and washed. The aspiration and/or dispense device **300** is used to transport a sample or reagent **302** (FIG. 3A). The exterior and interior surfaces of the aspiration and/or dispense device **300** include contaminants **304** (FIG. 3B). In some examples, the aspiration and/or dispense device **300** is washed to remove the contaminants **304**, and the aspiration and/or dispense device **300** is placed in the center of a coil **306** (FIG. 3C). The interior of the aspiration and/or dispense device **300** may also be cleared, but residual contaminants **308** may remain (FIG. 3D). Though FIGS. 3B-D shows the aspiration and/or dispense device **300** in the coil **306** during the prewash steps and the aspiration/dispense to clear the device **300**, these processes or operations may occur prior to insertion of the aspiration and/or dispense device **300** in the coil **306**.

An alternating current is passed through the coil **306** (FIG. 3D), which creates a magnetic field that induces eddy currents in the aspiration and/or dispense device **300**. The eddy currents generate heat, as disclosed above to denature and deactivate any contaminants on and/or in the aspiration and/or dispense device **300**. In some examples a post-wash treatment is provided to remove carbonized proteins **310** (FIG. 3E) or otherwise deactivated and/or unbound proteins **310** that may reside in the fluid channel and/or to cool the aspiration and/or dispense device **300**.

FIG. 4 illustrates an example circuit architecture for an electromagnetic field generator **400** that may be included, for example, in a medical diagnostic system or laboratory automation equipment like an automated pipetting system. The example includes a main power source **402**. In this example, the main power source **402** is the same power source for the entire medical diagnostic system. Thus, the main power source **402** is the same line voltage and frequency as used by the rest of the system and as received from a standard wall-mounted electrical outlet. Thus, in this example, there is no dedicated line or high voltage source used to power the electromagnetic field generator **400**. Instead, the main power is a low current, high voltage power. The example generator **400** includes a frequency generator **404** that generates the frequency needed to operate the generator **400**. In this example, the frequency may be, for example about 637 kHz. The frequency is adjustable and can be varied based on the characteristics of an aspiration and/or dispense device or other work piece to be placed in the magnetic field and heated.

In some examples, the frequency also is adjustable based on the type of reagent and/or sample including, for example, whether the contents of the aspiration and/or dispense device was previously a blood sample or will be a blood sample in a future use. For example, the frequency may be adjusted based on the amount of bound proteins that is expected for a particular type of sample. Thus, for example, the frequency/power could be reduced for "cleaner solutions" (i.e., solutions with an expectation of a lower amount of bound proteins or other biological carryover). The sample itself does not impact the rate of or generation of heat in the aspiration and/or dispense device.

In addition, the frequency may also be adjusted if, for example, a future test is particularly sensitive to carryover. In such examples, the frequency may be adjusted to maximize the heat for reducing and/or eliminating carryover. For example, if an assay has a particular sensitivity to carryover then a higher and/or a maximum available power and heat generation may be used to reduce and/or eliminate carryover.

Furthermore, in other examples, the frequency may be adjusted to use the lowest effective heat for a particular heating/cleaning cycle to reduce material stress on the probe, shorten a cycle time and/or maximize energy efficiency. In some examples, power usage and/or frequency is tailored based on an amount of contaminate aspirated. In such examples, a higher power may be used for a cleaning cycle that involves a relatively larger amount of probe length to be cleaned. Also, in some examples, a lower power may be used for cleaning a smaller area. In both of these examples, the time to clean could be consistent even though the power used and the length of the probe cleaned could be different. In addition, in some examples, the time for cleaning and, thus, the time an aspiration and/or dispense device spends heated in the electromagnetic field may be reduced where, for example, a small area of the aspiration and/or dispense device (e.g., probe) is to be cleaned and a relatively higher power is used. In some examples, the aspiration and/or dispense device does not experience a level of heat near a critical temperature at

which the material of the aspiration and/or dispense device begins to exhibit heat related issues. In addition, control of the frequency and, thus, the heat level, may be used to reduce the material stress, increase the useful life of the aspiration and/or dispense device and mitigate failure. Also, in some examples, when less power in the induction heater (e.g., in the coil) is desired, the frequency may be increased with relation to the nominal. This causes less strain on semiconductor switches (e.g., in the example systems **400**, **500**, **600**, **700** disclosed herein) when the driving frequency is higher than the resonant frequency because the switches are not "hard switching" against a potential.

The example generator **400** also includes a power controller **406** to control the flow of power from the main power source **402** at the frequency generated by the frequency generator **404**. A square wave signal or waveform is used in this example, but other waveforms also may be used including, for example, sinusoidal, triangular or saw tooth waveforms. An example input power may be about 450 Watts.

The example generator **400** also includes a transformer **408**. The transformer **408** steps down the voltage and increases the current. The transformer **408** also provides isolation between a resonant or tank circuit **410** and the main power **402**. The transformer **408** also provides a means of electrically matching the tank circuit **410** to the main power **402** and power controller **406** by magnifying or reducing the impedance of the tank circuit **410** as seen by the main power **402** and power controller **406** such that excessive current is not drawn by the generator **400**. In some examples, the transformer **408** may have a turns ratio of about 5.45:1. Thus, in this example, the current after the transformer **408** is about 5.45 times larger than the current before the transformer **408**, and the voltage after the transformer **408** is reduced by 5.45 times.

The tank circuit **410** is a parallel inductance-resistance-capacitance (LRC) circuit comprising a resistor **412** (the resistance of the system including transmission wires and the inherent resistance of the following components), an inductor **414** (the inductance of a both a coil **416** coupled to the transformer **408** and a work coil **418**) and a capacitor **420** connected in parallel with a value chosen so that the tank circuit **410** resonates at the frequency of the frequency generator **404**. The capacitor **420** provides the capacitance needed for the resonant circuit, and the work coil **418** provides the inductance and at least some of the resistance in the tank circuit **410**. In this example, the capacitor **420** is about 0.45 μF in parallel, and the work coil **418** has an inductance of about 1.4 μH . The tank circuit **410** further increases the current for the work coil **418**. The example work coil **418** operates as disclosed above to generate an alternating magnetic field which results in an opposing magnetic field generated by the work piece and therefore raises the surface temperature of any work piece disposed within a work space **422** in the interior of the work coil **418**. In this example, the pre-transformer current is about 4.4 A, the post-transformer current is about 24 A. The tank circuit **410**, in this example, increases the current further to about 240 A, resulting in an overall increase of about 54.5-fold at the work coil **418**. Also, the example work coil **418** may raise the surface temperature of a work piece such as an aspiration and/or dispense device 0-100° C. in less than one second, 0-300° C. in one to two seconds, and 700-800° C. within seven seconds.

There are several design considerations for optimizing the operation of the example generator **400** including, for example, coil design and selection (inductance magnitude, resistance value, small gap between the coils and the work piece), the component to be heated (physical dimensions,

material composition), the amount of main power available (voltage, current), the desired heating rate, the desired maximum temperature and the type of heating desired (through heating, surface heating). These considerations affect the components used in the example generator **400** including, for example, the nominal frequency generated at the frequency generator **404** (for heating the work piece), the capacitance needed (Farad value and kVAR value), the tank circuit **410** multiplication value (Q), the phase angle of the tank circuit **410** (ϕ) (unity power factor at $\cos(\phi)=1$), the ratio and location of the transformer **408**, power source design, and connecting wire selection (to minimize stray induction and voltage drop).

Specifically, the frequency to be used for a particular work piece depends on the desired or physical skin thickness of the work piece, and the thickness depends on the outer diameter of the work piece assuming but not limited to a cylindrical cross-section, the wall thickness and the material composition. The skin thickness is defined as the depth where, for example, about 86% of the induced power is generated. The optimum depth for a tube or cylindrically-shaped work piece is defined by Equation (1) below.

$$3.5 = \frac{t \cdot d}{\delta^2} \quad \text{Eqn. (1)}$$

In Equation (1), the skin thickness is represented by δ , t =wall thickness (m), and d =tube diameter (m). Equation (1) can be solved for the skin thickness, which can be used in Equation (2) below to calculate the frequency, f .

$$\delta = \sqrt{\frac{\rho}{\pi \cdot \mu \cdot f}} \quad \text{Eqn. (2)}$$

In Equation 2, resistivity is represented by ρ ($\mu\Omega\text{m}$) and μ represents the magnetic permeability (H/m). Equation (2) can be solved to determine the frequency, f (Hz).

Selection of components for the tank circuit **410** depend on the desired frequency f (Hz), the capacitance C (F), and the inductance L (H) as shown below in Equation (3).

$$f = \frac{1}{2\pi\sqrt{LC}} \quad \text{Eqn. (3)}$$

In addition, the Q factor of the tank circuit **410** may be controlled or manipulated via the kilo-volt ampere reactive (kVAR), power (W), the angular frequency to (rad/s), the capacitance C (F), the voltage (V), the current I (A), the resistance R (Ω), inductance L (H) and/or the inductive reactance X_L (Ω) as shown below in Equation (4).

$$Q = \frac{kVAR}{kW} = \frac{VAR}{W} = \frac{\omega CV^2}{I^2 R} = \frac{\omega L}{R} = \frac{X_L}{R} \quad \text{Eqn. (4)}$$

A higher Q value produces a smaller bandwidth, which is more difficult to tune for resonance but provides a higher current multiplication in the tank circuit **410**. Whereas a smaller Q value allows for a larger bandwidth, which is easier to tune for resonance and more resistant to de-tuning but provides a lower current multiplication in the tank circuit **410**. After the components for the tank circuit have been selected,

the impedance Z (Ω) of the circuit may be calculated and the ratio of the transformer **408** may be selected for correct matching and to not draw excessive current from the main power source **402**. The impedance Z_{eq} (Ω) of the tank circuit depends on the angular frequency ω (rad/s), the capacitance C (F), the equivalent series resistance of the capacitor R_C (Ω), the series resistance of the inductor R_L (Ω), inductance L (H), equivalent circuit resistance R_{eq} (Ω), and equivalent circuit impedance X_{eq} (Ω), as shown below in Equations (5), (6) and (7).

$$Z_{eq} = R_{eq} + jX_{eq} = |Z|e^{j\phi} \quad \text{Eqn. (5)}$$

$$R_{eq} = \frac{\left(R_L R_C + \frac{L}{C}\right)(R_L + R_C) + \left(\omega L R_C - \frac{R_L}{\omega C}\right)\left(\omega L - \frac{1}{\omega C}\right)}{(R_L + R_C)^2 + \left(\omega L - \frac{1}{\omega C}\right)^2} \quad \text{Eqn. (6)}$$

$$X_{eq} = \frac{\left(\omega L R_C - \frac{R_L}{\omega C}\right)(R_L + R_C) - \left(R_L R_C + \frac{L}{C}\right)\left(\omega L - \frac{1}{\omega C}\right)}{(R_L + R_C)^2 + \left(\omega L - \frac{1}{\omega C}\right)^2} \quad \text{Eqn. (7)}$$

The optimal transformer ratio Y_t depends on the voltage of the supplied power V_{ps} (V), the maximum current that can be safely drawn from the supplied power I_{max} (A), and the impedance of the tank circuit Z_{eq} (Ω), and the resistance as seen by the power supply R_{ps} (Ω), as shown below in Equations (8) and (9).

$$R_{ps} = Z_{eq} Y_t^2 = \frac{V_{ps}}{I_{max}} \quad \text{Eqn. (8)}$$

$$Y_t = \sqrt{\frac{V_{ps}}{I_{max} Z_{eq}}} \quad \text{Eqn. (9)}$$

The above equations describe the turn ratio of the transformer **408** that provides the maximum amount of power drawn from the power source **402**. If a ratio larger than the ratio shown in Equation 9 is chosen, the current draw from the main power source **402** will be reduced and the overall power consumption of the generator **400** will decrease.

FIG. 5 illustrates another example circuit architecture for an electromagnentic field generator **500** that may be included, for example, in a medical diagnostic system or automated pipetting system. Components that are similar to components described in other examples will not be repeated here for this example or for subsequent examples, though the values of the components may be different. For example, the current source, frequency, capacitor, etc. may have different values but operate in a similar manner as disclosed above. The example generator **500** of FIG. 5 includes a transformer with a ratio larger than the optimal selection. In this example shown in FIG. 5, a 643 kHz square wave may be generated by the frequency generator **404**. A current source **506**, which incorporates aspects of the main power source **402** and power controller **406** of FIG. 4, produces, in this example, a current of about 3.3 A. The first transformer **502** and the second transformer **504** together form, in this example, a transformer having a turn ratio of about 16:1. Thus, the current multiplication is sixteen times greater after the transformers **502**, **504**. In this example, the post-transformer current is about 52.8 A. The tank circuit **410**, in this example, increases the current further to about 160 A, resulting in an overall increase of about 48-fold at the work coil **418**. In this example, the overall

system power is reduced, but the draw on the current source **506** is reduced to match the requirements desired in this example.

FIG. 6 illustrates another example circuit architecture for an electromagnetic field generator **600** that may be included, for example, in a medical diagnostic system or automated pipetting system. The example generator **600** of FIG. 6 includes a controller **602** and one or more feedback loop(s) **604**. The feedback loop(s) **604** provide data to the controller **602** regarding various metrics of the generator **600** such as, for example, a frequency, an impedance, a temperature, a presence of an aspiration and/or dispense device **606** in the electromagnetic field of the work coil **418**, a voltage reading and/or a current reading at any point in the system. The presence or absence of the aspiration and/or dispense device **606** is detectable through temperature or load changes at the work coil **418**. In addition, a physical characteristic of the aspiration and/or dispense device **606** may change as an arm **608** moves the aspiration and/or dispense device **606** up or down through the work coil **418** to change the surface of the aspiration and/or dispense device **606** that is disposed in the magnetic field and, therefore, subject to inductive heating. For example, the example aspiration and/or dispense device **606** has a smaller diameter (i.e., is tapered) toward a tip **610**. The optimal frequency to adequately heat the tip **610** is different than the frequency needed to adequately heat a portion of the aspiration and/or dispense device **606** with a larger diameter. Thus, the controller **602** may adjust the frequency to change a strength of the electromagnetic field to optimize a heating temperature of the aspiration and/or dispense device **606** based on the data.

The controller **602** also acts as a calibrator to enable the generator **600** to self-calibrate based on drifting of the capacitance or impedance over time. The controller **602** further may also sense shorts and/or other problems with the any components of the generator **600** or interconnections therebetween.

FIG. 7 illustrates another example circuit architecture for an electromagnetic field generator **700** that may be included, for example, in a medical diagnostic system or automated pipetting system. The example generator **700** of FIG. 7 includes a step-up/down transformer **702** coupled to the main power **402** and a rectifier **704**. The step-up/down transformer **702** and rectifier **704** are separate components in some examples and are integrated with the power supply **402** in other examples. The step-up/down transformer **702** and the rectifier **704** enable the generator **700** to draw power from the power supply **402** and manipulate that power into a direct current (DC) signal having a suitable voltage and current capacity. Thus, the generator **700** may be coupled to an electrical wall outlet in any country and the step-up/down transformer **702** and rectifier **704** may be selected and/or adjusted to adjust to the power available from the electrical outlet in the wall. Thus, the transformer **702** and/or rectifier **704** may be selected such that the system does not draw excessive current from the main power supply **402**. In some examples, the step-up/down transformer **702** and the rectifier **704** modify the power to change the power supply **402** supplied AC voltage to DC voltage, to have a voltage of 120V and 10 A of current and/or otherwise adjust the supplied power. The example generator **700** also include additional feedback loops **706** to provide further data to the controller **602** such as, for example, current readings, voltage readings or any other suitable data.

While an example manner of implementing generators **400**, **500**, **600**, **700** has been illustrated in FIGS. 4-7, one or more of the elements, processes and/or devices illustrated in FIGS. 4-7 may be combined, divided, re-arranged, omitted,

eliminated and/or implemented in any other way. Further, the example frequency generator **402**, power controller **406**, current source **506**, system controller **602**, rectifier **704** and/or, more generally, the example generators **400**, **500**, **600**, **700** of FIGS. 4-7 may be implemented by hardware, software, firmware and/or any combination of hardware, software and/or firmware whether as part of a medical diagnostic device or as a standalone induction heating cleaning device. Thus, for example, any of the example frequency generator **402**, power controller **406**, current source **506**, system controller **602**, rectifier **704** and/or, more generally, the example generators **400**, **500**, **600**, **700** of FIGS. 4-7 could be implemented by one or more circuit(s), programmable processor(s), application specific integrated circuit(s) (ASIC(s)), programmable logic device(s) (PLD(s)) and/or field programmable logic device(s) (FPLD(s)), etc. When any of the apparatus or system claims of this patent are read to cover a purely software and/or firmware implementation, at least one of the example, frequency generator **402**, power controller **406**, current source **506**, system controller **602** and/or rectifier **704** are hereby expressly defined to include a tangible computer readable medium such as a memory, DVD, CD, Blu-ray, etc. storing the software and/or firmware. Further still, the example generator **400**, **500**, **600**, **700** of FIGS. 4-7 may include one or more elements, processes and/or devices in addition to, or instead of, those illustrated in FIGS. 4-7, and/or may include more than one of any or all of the illustrated elements, processes and devices.

A flowchart representative of an example process that may be used to implement the apparatus and systems of FIGS. 1-7 is shown in FIG. 8. In this example, the process comprises a program for execution by a processor such as the processor **912** shown in the example computer **9000** discussed below in connection with FIG. 9. The program may be embodied in software stored on a tangible computer readable medium such as a CD-ROM, a floppy disk, a hard drive, a digital versatile disk (DVD), a Blu-ray disk, or a memory associated with the processor **912**, but the entire program and/or parts thereof could alternatively be executed by a device other than the processor **912** and/or embodied in firmware or dedicated hardware. Further, although the example program is described with reference to the flowchart illustrated in FIG. 8, many other methods of implementing the example systems and apparatus disclosed herein may alternatively be used. For example, the order of execution of the blocks may be changed, and/or some of the blocks described may be changed, eliminated, or combined.

As mentioned above, the example process of FIG. 8 may be implemented using coded instructions (e.g., computer readable instructions) stored on a tangible computer readable medium such as a hard disk drive, a flash memory, a read-only memory (ROM), a compact disk (CD), a digital versatile disk (DVD), a cache, a random-access memory (RAM) and/or any other storage media in which information is stored for any duration (e.g., for extended time periods, permanently, brief instances, for temporarily buffering, and/or for caching of the information). As used herein, the term tangible computer readable medium is expressly defined to include any type of computer readable storage and to exclude propagating signals. Additionally or alternatively, the example process of FIG. 8 may be implemented using coded instructions (e.g., computer readable instructions) stored on a non-transitory computer readable medium such as a hard disk drive, a flash memory, a read-only memory, a compact disk, a digital versatile disk, a cache, a random-access memory and/or any other storage media in which information is stored for any duration (e.g., for extended time periods, permanently, brief

instances, for temporarily buffering, and/or for caching of the information). As used herein, the term non-transitory computer readable medium is expressly defined to include any type of computer readable medium and to exclude propagating signals. As used herein, when the phrase “at least” is used as the transition term in a preamble of a claim, it is open-ended in the same manner as the term “comprising” is open-ended. Thus, a claim using “at least” as the transition term in its preamble may include elements in addition to those expressly recited in the claim.

FIG. 8 illustrates a process 800 of carryover reduction which includes, for example, denaturing and/or deactivating proteins and/or other biological materials, sterilization, cleaning, etc. In some examples, the process 800 includes prewashing or otherwise pretreating a probe or other aspiration and/or dispense device (block 802) using, for example one or more of the prewashes of FIGS. 2 and 3. The example process 800 also includes generating an electromagnetic field (block 804). An example electromagnetic field may be generated by, for example, the coils 100, 204, 306, 418 of FIGS. 1-7 and/or the generators 400, 500, 600, 700 of FIGS. 4-7. In some examples, the electromagnetic field is an alternating electromagnetic field generated by an AC power supply.

In the example process 800 of FIG. 8, the presence or absence of a probe is detected (block 806). If a probe is not detected, control remains at block 806 until a probe has been introduced into the generated electromagnetic field. When a probe has been introduced into the electromagnetic field, the example process 800 determines if the electromagnetic field should be adjusted (block 808). For example, the controller 602 may sense that the dimensions of the probe in the work coil 418 require a different frequency to optimize the electromagnetic field and the resulting induced heat, and the process 800 makes the adjustment (block 810). If no adjustment is necessary or after an adjustment has been made, the process 800 continues, and the probe is heated (block 812). During the heating of the probe (block 812), the position of the probe may be adjusted (e.g., raised or lowered) with respect to the electromagnetic field and the coil to change a portion of the probe that is subjected to the field and the related inductive heating. After the desired temperature and/or duration of heating of the probe to denature and/or deactivate any biological matter, one or more optional postwash steps may occur (block 814). For example, a postwash may rinse the probe of carbonized proteins and/or other residue, a cooling wash may lower the temperature of the probe, and/or other post-treatments may occur. The example process 800 ends (block 816) and the probe is reusable.

FIG. 9 is a block diagram of an example computer 900 capable of executing the process of FIG. 8 to implement the apparatus of FIGS. 1-7. The computer 900 can be, for example, a server, a personal computer, or any other type of computing device.

The system 900 of the instant example includes a processor 912. For example, the processor 912 can be implemented by one or more microprocessors or controllers from any desired family or manufacturer.

The processor 912 includes a local memory 913 (e.g., a cache) and is in communication with a main memory including a volatile memory 914 and a non-volatile memory 916 via a bus 918. The volatile memory 914 may be implemented by Synchronous Dynamic Random Access Memory (SDRAM), Dynamic Random Access Memory (DRAM), RAMBUS Dynamic Random Access Memory (RDRAM) and/or any other type of random access memory device. The non-volatile memory 916 may be implemented by flash memory and/or

any other desired type of memory device. Access to the main memory 914, 916 is controlled by a memory controller.

The computer 900 also includes an interface circuit 920. The interface circuit 920 may be implemented by any type of interface standard, such as an Ethernet interface, a universal serial bus (USB), and/or a PCI express interface.

One or more input devices 922 are connected to the interface circuit 920. The input device(s) 922 permit a user to enter data and commands into the processor 912. The input device(s) can be implemented by, for example, a keyboard, a mouse, a touchscreen, a track-pad, a trackball, isopoint and/or a voice recognition system.

One or more output devices 924 are also connected to the interface circuit 920. The output devices 924 can be implemented, for example, by display devices (e.g., a liquid crystal display, a cathode ray tube display (CRT), a printer and/or speakers). The interface circuit 920, thus, typically includes a graphics driver card.

The interface circuit 920 also includes a communication device such as a modem or network interface card to facilitate exchange of data with external computers via a network 926 (e.g., an Ethernet connection, a digital subscriber line (DSL), a telephone line, coaxial cable, a cellular telephone system, etc.).

The computer 900 also includes one or more mass storage devices 928 for storing software and data. Examples of such mass storage devices 928 include floppy disk drives, hard drive disks, compact disk drives and digital versatile disk (DVD) drives.

Coded instructions 932 to implement the process 800 of FIG. 8 may be stored in the mass storage device 928, in the volatile memory 914, in the non-volatile memory 916, and/or on a removable storage medium such as a CD or DVD.

From the foregoing, it will be appreciated that the above disclosed methods, apparatus, systems and articles of manufacture can be used to inductively heat aspiration and/or dispense devices in medical diagnostic equipment or automated pipetting system. These examples enable the heating of such aspiration and/or dispense devices without requiring physical or electrical contact with the aspiration and/or dispense device. The risk of an electrical short is reduced, and a lower voltage may be used. Also, less heat is required to sterilize, denature or deactivate proteins and other biological matter and/or otherwise clean the aspiration and/or dispense devices. Thus, the time required for the example processes disclosed herein is also reduced. In addition, the heat is controlled and evenly spread through the targeted surface, and the entire aspiration and/or dispense device does not have to be heated. Also, induction heating of the aspiration and/or dispense devices enables the devices to be reused. Induction heating produces negligible solid waste and significantly less biohazardous waste. The example systems and apparatus disclosed herein can be plugged into any electrical wall outlet and do not require dedicated power supply lines for the electromagnetic field generators. Induction heating offers a safe, controllable, fast and low incremental cost method for preventing and/or eliminating carryover or cross contamination of proteins and/or other biological matter.

Although certain example methods, apparatus and articles of manufacture have been described herein, the scope of coverage of this patent is not limited thereto. On the contrary, this patent covers all methods, apparatus and articles of manufacture fairly falling within the scope of the claims of this patent.

15

What is claimed is:

1. A method of comprising:

washing an aspiration and dispense device;
generating an alternating electromagnetic field;
introducing the aspiration and dispense device into the
electromagnetic field, wherein the washing occurs prior
to introducing the aspiration and dispense device into the
electromagnetic field; and
inductively heating the aspiration and dispense device with
the electromagnetic field to at least one of denature or
deactivate at least one of a protein or a biological entity
on a surface of the aspiration and dispense device.

2. The method of claim **1**, wherein the generating the
electromagnetic field comprises flowing a current through an
electrically conducting media using a frequency that is based
on a diameter of the aspiration and dispense device.

3. The method of claim **2**, wherein the electrically conduct-
ing media is a coil.

4. The method of claim **2**, further comprising using a first
frequency to heat a tip of the aspiration and dispense device
and a second frequency to heat a body of the aspiration and
dispense device, the tip having a first diameter and the body
having a second diameter.

5. The method of claim **1**, wherein the generating the
electromagnetic field comprises flowing a current through an
electrically conducting media using a frequency that is based
on a thickness of a skin of the aspiration and dispense device.

6. The method of claim **1** further comprising inductively
heating only a portion of the aspiration and dispense device.

7. The method of claim **6**, further comprising using a first
frequency to inductively heat a first portion of the aspiration
and dispense device and a second frequency to inductively
heat a second portion of the aspiration and dispense device,
the first portion smaller than the second portion.

8. The method of claim **1**, wherein generating the alternat-
ing electromagnetic field comprises using a standard electri-
cal wall outlet.

9. The method of claim **1** further comprising:

disposing a wash cup between the aspiration and dispense
device and an electrically conducting media used to
create the electromagnetic field; and
preventing direct contact between the aspiration and dis-
pense device and the electrically conducting media with
the wash cup.

10. The method of claim **9**, wherein the wash cup com-
prises an electrically insulating or non-metallic material.

11. The method of claim **2**, wherein the at least one of a
protein or the biological entity is disposed on one or more of
an interior surface or an exterior surface of the aspiration and
dispense device.

12. The method of claim **1**, further comprising adjusting a
frequency current based on a load associated with the aspira-
tion and dispense device.

13. A method comprising:

generating an alternating electromagnetic field;
introducing an aspiration and dispense device into the elec-
tromagnetic field;
inductively heating the aspiration and dispense device with
the electromagnetic field to at least one of denature or
deactivate at least one of a protein or a biological entity
on a surface of the aspiration and dispense device; and
washing the aspiration and dispense device after inductively
heating the aspiration and dispense device with
the electromagnetic field.

14. The method of claim **13**, wherein the washing com-
prises washing with a cooling wash to lower a temperature of
the aspiration and dispense device.

16

15. The method of claim **13**, further comprising adjusting a
frequency current based on a load associated with the aspira-
tion and dispense device.

16. The method of claim **13**, wherein the generating the
electromagnetic field comprises flowing a current through an
electrically conducting media using a frequency that is based
on a diameter of the aspiration and dispense device.

17. The method of claim **13** further comprising:

disposing a wash cup between the aspiration and dispense
device and an electrically conducting media used to
create the electromagnetic field; and
preventing direct contact between the aspiration and dis-
pense device and the electrically conducting media with
the wash cup.

18. A method comprising:

generating an alternating electromagnetic field;
introducing an aspiration and dispense device into the elec-
tromagnetic field;
inductively heating the aspiration and dispense device with
the electromagnetic field to at least one of denature or
deactivate at least one of a protein or a biological entity
on a surface of the aspiration and dispense device; and
washing the aspiration and dispense device during inductively
heating the aspiration and dispense device with
the electromagnetic field.

19. The method of claim **18**, further comprising adjusting a
frequency current based on a load associated with the aspira-
tion and dispense device.

20. The method of claim **18**, wherein the generating the
electromagnetic field comprises flowing a current through an
electrically conducting media using a frequency that is based
on a diameter of the aspiration and dispense device.

21. The method of claim **18** further comprising:

disposing a wash cup between the aspiration and dispense
device and an electrically conducting media used to
create the electromagnetic field; and
preventing direct contact between the aspiration and dis-
pense device and the electrically conducting media with
the wash cup.

22. A method comprising:

generating an alternating electromagnetic field by flowing
a current through an electrically conducting media using
a frequency that is based on a thickness of a skin of an
aspiration and dispense device;
introducing the aspiration and dispense device into the
electromagnetic field;
inductively heating the aspiration and dispense device with
the electromagnetic field to at least one of denature or
deactivate at least one of a protein or a biological entity
on a surface of the aspiration and dispense device; and
raising or lowering the aspiration and dispense device
through the electromagnetic field to inductively heat the
aspiration and dispense device along a length of the
aspiration and dispense device.

23. The method of claim **22**, wherein the thickness of the
skin varies along the length of the aspiration and dispense
device and the method further comprises adjusting the fre-
quency as the aspiration and dispense device is raised or
lowered.

24. The method of claim **22**, further comprising adjusting a
frequency current based on a load associated with the aspira-
tion and dispense device.

25. The method of claim **22**, wherein the generating the
electromagnetic field comprises flowing a current through an
electrically conducting media using a frequency that is based
on a diameter of the aspiration and dispense device.

17

26. The method of claim 22 further comprising:
disposing a wash cup between the aspiration and dispense
device and an electrically conducting media used to
create the electromagnetic field; and

preventing direct contact between the aspiration and dis- 5
pense device and the electrically conducting media with
the wash cup.

27. A method comprising:

generating an alternating electromagnetic field;

detecting a presence of an aspiration and dispense device in 10
the electromagnetic field based on a temperature change
or a load change with respect to an electromagnetic field
generator; and

inductively heating the aspiration and dispense device with 15
the electromagnetic field to at least one of denature or
deactivate at least one of a protein or a biological entity
on a surface of the aspiration and dispense device.

28. The method of claim 27, further comprising adjusting a
frequency current based one or more of (a) contents of the
aspiration and dispense device prior to exposure to the elec-

18

tromagnetic field or (b) contents to be disposed in the aspira-
tion and dispense device after exposure to the electromag-
netic field.

29. The method of claim 28, further comprising adjusting
the frequency current based on an amount of proteins associ-
ated with the contents of the aspiration and dispense device
prior to exposure to the electromagnetic field.

30. The method of claim 27, further comprising adjusting a
frequency current based on the load change.

31. The method of claim 27, wherein the generating the
electromagnetic field comprises flowing a current through an
electrically conducting media using a frequency that is based
on a diameter of the aspiration and dispense device.

32. The method of claim 27 further comprising:

disposing a wash cup between the aspiration and dispense
device and an electrically conducting media used to
create the electromagnetic field; and

preventing direct contact between the aspiration and dis-
pense device and the electrically conducting media with
the wash cup.

* * * * *