

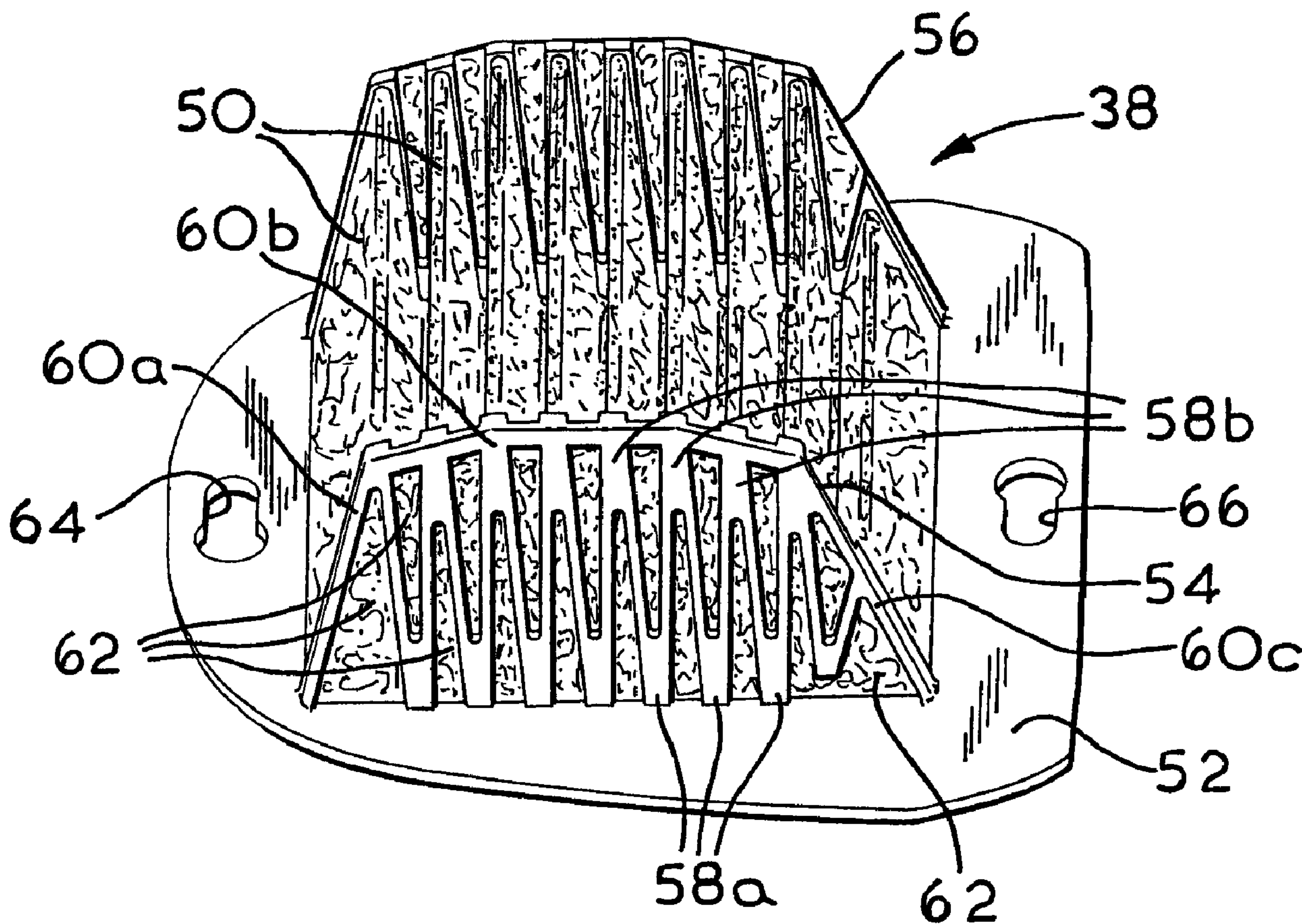

(22) Date de dépôt/Filing Date: 2000/07/14  
 (41) Mise à la disp. pub./Open to Public Insp.: 2001/01/17  
 (45) Date de délivrance/Issue Date: 2010/02/09  
 (62) Demande originale/Original Application: 2 313 953  
 (30) Priorité/Priority: 1999/07/17 (GB9916759.5)

(51) Cl.Int./Int.Cl. *A47L 9/12* (2006.01)  
 (72) Inventeurs/Inventors:  
 BONE, DANNY, GB;  
 COCKBURN, ERIC, GB;  
 PEARS, BARRY, GB  
 (73) Propriétaire/Owner:  
 BLACK & DECKER INC., US  
 (74) Agent: SIM & MCBURNEY

(54) Titre : AMELIORATIONS APORTEES AUX ASPIRATEURS  
 (54) Title: IMPROVEMENTS IN VACUUM CLEANERS



(57) Abrégé/Abstract:

A dual filter arrangement for a vacuum cleaner for filtering particles of dust and debris from an airflow passing through the vacuum cleaner, comprising a coarse pre-filter having an array of pores formed therein of substantially uniform diameter and a fine primary filter which is located rearwardly of the pre-filter in the direction of flow of the airflow.

**ABSTRACT**

**Improvements in Vacuum Cleaners**

A dual filter arrangement for a vacuum cleaner for filtering particles of dust and debris from an airflow passing through the vacuum cleaner, comprising a coarse pre-  
5 filter having an array of pores formed therein of substantially uniform diameter and a fine primary filter which is located rearwardly of the pre-filter in the direction of flow of the airflow.

## Improvements in Vacuum Cleaners

The present invention relates to improvements in the filter arrangements used in vacuum cleaners and in particular to improvements in the filter arrangements used in  
5 hand held battery operated vacuum cleaners.

In many known vacuum cleaners a motor powered either by a mains electricity supply or a battery pack, which may be rechargeable, rotatingly drives a fan. The fan generates an airflow within which particles of dust and debris to be collected by the  
10 vacuum cleaner become entrained. The airflow generally enters the vacuum cleaner via an inlet nozzle and passes through a filter so that particles of dust and debris entrained in the airflow are removed from the airflow by the filter and are collected in a collecting chamber. A problem with this type of vacuum cleaner is that after some use the pores of the filter can become blocked by particles of dust and debris which  
15 tend to bind together to form relatively large conglomerations. Once the filter becomes blocked the airflow through it is reduced and the suction power of the vacuum cleaner is reduced.

In its simplest form the filter can be a piece of woven polyester material supported in  
20 a frame and located between a collecting chamber and the fan. Such a simple filter will filter out the majority of particles of dust and debris from the airflow drawn into the fan some of which particles then drop into the collecting chamber. However, such simple filters do tend to become blocked relatively quickly and can be ineffective to filter out smaller particles of dust and debris from the airflow.

25  
Improved filters are known in which the filter comprises a concertina of filter material, in order to increase the surface area of the filter whilst not taking up too much space within the vacuum cleaner. However, these can also become blocked through use and the folds in the concertina of filter material provide crevices in which  
30 conglomerations of particles of dust and debris can accumulate. In such filters the filter material has to be made of materials which maintain their shape once folded,

which can increase the expense of the filter material used, particularly if a fine filter is required.

5 It is important that the filter arrangement used in the vacuum cleaner is effectively sealed within the housing of the vacuum cleaner so that none of the airflow within which dust and debris is entrained leaks around the sides of the filter. It is desirable that all the airflow through the fan passes through the filter so that all the particles of dust and debris entrained in the airflow are filtered out and collected in a collecting chamber. Such a seal for a filter will have to be effective throughout the lifetime of  
10 the vacuum cleaner and may have to withstand regular disassembly of the parts of the vacuum cleaner surrounding it in order that the collecting chamber can be emptied and possibly so that the filter itself can be cleaned.

15 In some vacuum cleaners the filter is regularly removed from the housing of the vacuum cleaner so that it can be cleaned. In such vacuum cleaners it is desirable to be able to remove and replace the filter easily and without reducing the strength of any seal between the filter and components of the vacuum cleaner surrounding it.

20 A first aspect of the present invention seeks to overcome some of the problems discussed above by providing a filter arrangement for a vacuum cleaner which is less vulnerable to blocking by particles of dust and debris. A second aspect of the present invention seeks to overcome some of the disadvantages discussed above by providing a high surface area and low volume filter in which relatively inexpensive flexible fine filter material can be used. A third aspect of the present invention seeks to overcome  
25 some of the problems discussed above by providing a filter arrangement with improved sealing to adjacent components. A fourth aspect of the present invention seeks to overcome some of the disadvantages discussed above by providing a releasable fixing arrangement for a filter arrangement within a vacuum cleaner which is easy to operate and maintains a good seal around the filter arrangement when the  
30 arrangement is fixed within the vacuum cleaner.

According to the present invention, there is provided a dual filter arrangement for a vacuum cleaner for filtering particles of dust and debris from an airflow passing through the vacuum cleaner, the dual filter arrangement comprising;

5                   a coarse pre-filter; and

                  a fine primary filter which is located rearwardly of the pre-filter in the direction of flow of the airflow;

10           wherein the pre-filter has a peripheral rim via which it is fitted to at least one of the primary filter and a housing part of a vacuum cleaner, a peripheral seal element made of a resilient material surrounds said rim, and the pre-filter is adapted to be releasably latched to a first housing portion of a vacuum cleaner by a latching arrangement against a biasing force generated by the seal element.

15

Clearly, the pre-filter will prevent a proportion of the particles of dust and debris entrained in the airflow from reaching the primary filter and thus will reduce the blocking of the primary filter. Furthermore, the use of a coarse pre-filter means that the size of particle reaching the primary filter will be of more uniform diameter than if  
20           the pre-filter was not present, because all particles reaching the primary filter will have diameters less than the diameter of the pores in the pre-filter. It has been found that particulate material of more uniform diameter is more resistant to binding than particulate material of greatly varying diameter. This further reduces the tendency of the primary filter to become blocked because the particulate matter incident on it is

3a

less inclined to bind together to form the conglomerated masses of dust and debris particles which are responsible for the blocking up of the filter. In this way the majority of particles of dust or debris incident on the primary filter will fall away from the surface thereof and can be collected.

5

Preferably, the diameter of the pores of the pre-filter is set at a substantially uniform value, preferably at a value within the range 0.75mm to 1.75mm and in particular a value of 1mm. It would generally be expected that using such large diameter pores would not deflect particulate matter of smaller size, such as average sized dust particles from the airflow. However, the pre-filter with an array of substantially uniform diameter pores with a diameter set at a value within this preferred range serves to deflect a significant amount of particles of dust and debris picked up in a standard manner by a vacuum cleaner and entrained in an airflow passing through it irrespective of the particle size. When the particles entrained in the airflow hit the pre-filter, their momentum is reduced or eliminated and the airflow is often insufficiently strong to recapture such particles which then fall out of the airflow and

10

15

can be collected. This significantly reduces the volume of particulate material which reaches the primary filter and so will reduce blocking of the primary filter further.

It is preferred that the primary filter comprises a concertina shaped arrangement of a  
5 fine filter material in order to provide a high surface area and low volume primary filter. It is preferred that the primary filter comprises a frame comprising two opposing arrays of arms and the concertina shaped arrangement of fine filter material is supported between opposing pairs of said arms. This support for the fine filter material enables more inexpensive and flexible fine filter material to be used because  
10 the filter material is supported in the concertina formation and so does not have to maintain this formation due to its own rigidity. In a preferred arrangement said opposing arrays of arms are each arranged to form a corrugated or zig-zag formation and so are conveniently positioned to support the entire length of the opposing sides of a strip of filter material folded into a concertina formation. To further increase the  
15 surface area of the primary filter without increasing its volume it is preferred that additional pieces of fine filter material are located between adjacent arms of the arrays of arms. To ease manufacture it is preferred that the frame of the primary filter comprises a moulded plastics material.

20 In order to reduce the volume taken up by the dual filter arrangement without decreasing its performance it is preferred that the pre-filter is formed with a recess within which the primary filter is received.

In a preferred embodiment the pre-filter comprises an open box shaped structure in  
25 which the array of pores is located in at least one of the sides of the structure and more preferably the array of pores is located in all five sides of the structure.

The pre-filter may conveniently be made from a moulded plastics material. Preferably, such plastics material will comprise a low friction material, such as  
30 polypropylene, and may be an anti-static compound such as achieved by mixing carbon with polypropylene.

It is preferred that said seal element comprises a first rearwardly extending resilient portion which extends around the periphery of the rim of the pre-filter towards the primary filter and which surrounds the periphery of the primary filter when the dual filter arrangement is fitted to a vacuum cleaner. This helps to provide a closure  
5 between the peripheries of the pre-filter and the primary filter which is preferably sealed by ensuring that the first rearwardly extending resilient portion extends rearwardly beyond the primary filter to engage a first housing part of a vacuum cleaner to form a seal therewith when the dual filter arrangement is fitted to a vacuum cleaner. This also provides a seal between the dual filter arrangement and the first  
10 housing part.

It is further preferred that the seal element comprises a second rearwardly extending resilient portion which extends around the periphery of the rim of the pre-filter towards the primary filter to engage a peripheral rim of the primary filter to form a  
15 seal therewith when the dual filter arrangement is fitted to a vacuum cleaner. This provides further sealing between the pre-filter and the primary filter to prevent dust laden airflow leaking therebetween.

In a preferred embodiment the seal element may comprise a substantially radially  
20 outwardly extending resilient portion which extends around the periphery of the rim of the pre-filter to engage a second housing part of a vacuum cleaner to form a seal therewith when the dual filter arrangement is fitted to a vacuum cleaner. Preferably, a radially inwardly extending wall is provided on the second housing part of the vacuum cleaner and a front facing surface of the radially outwardly extending resilient  
25 portion engages a rearwardly facing surface of said wall to form a seal therebetween. It is further preferred that in use of the vacuum cleaner the seal between the radially outwardly extending resilient portion and the radially inwardly extending wall is reinforced by a pressure differential generated by an underpressure located in front of the dual filter arrangement.

30

Alternatively, the sealing element may comprise a substantially radially outwardly extending resilient portion which extends around the periphery of the rim of the pre-

filter wherein the periphery of the radially outwardly extending resilient portion is arranged such that it does not engage the second housing part of the vacuum cleaner when the vacuum cleaner is not in use but when the vacuum cleaner is in use a pressure differential generated by an underpressure located in front of the dual filter  
5 arrangement urges the periphery of the radially outwardly extending resilient portion into engagement with the second housing part to form a seal therewith. Since the seal is not in frictional engagement with the second housing part when the second housing part is removed it provides for easier removal of that second housing part.

10 The second housing part referred to may comprise the wall of a removable nose cone of the vacuum cleaner through which dust and debris are sucked into the vacuum cleaner.

The seal element may be made of any resilient sealing material, such as rubber,  
15 neoprene, silicones or other suitable elastomers.

Conveniently, the seal element may be moulded around the periphery of the rim of the pre-filter.

20 Preferably, at least one cam surface is located between co-operating latching parts of the latching arrangement, such that the movement of at least one of the latching parts over the cam surface during the unlatching movement causes the seal element to be compressed beyond the degree of compression of the seal element when the pre-filter is latched to the first housing portion. Thus, the seal element has the dual function of  
25 providing sealing and of providing resilient biasing of the latching arrangement, thus providing a potential reduction of component parts.

In a preferred embodiment at least one keyhole shaped aperture is provided in the rim of the pre-filter through which can be releasably latched a co-operating latch element  
30 which extends from the first housing portion. The or each latch element may comprise a peg with an enlarged head which can fit within the widened portion of the aperture and a stem which can fit within the narrow portion of the aperture. In this

preferred embodiment the cam surface may surround the aperture and may comprise at least one ridge over which the co-operating latch element must ride when moving into or out of the latched position.

- 5 Preferably, the primary filter has a peripheral rim via which it is releasably latched between the pre-filter and the first housing portion.

The first housing portion of the vacuum cleaner referred to above may be a housing portion which surrounds an inlet to a fan of the vacuum cleaner.

10

One aspect of the present invention provides a concertina filter arrangement for a vacuum cleaner for filtering particles of dust and debris from airflow passing through the vacuum cleaner, comprising a frame and a concertina shaped arrangement of filter material supported and maintained by the frame, wherein the frame comprises opposing array of arms forming a  
15 substantially zigzag formation such that the filter material is supported by said opposing array of arms, wherein additional pieces of fine filter material are located between adjacent arms of the *array* of arms.

The present invention will now be described by way of example only with reference to the  
20 following Figures in which:

Figure 1 shows a longitudinal cross-section of a hand held battery powered vacuum comprising a dual filter system according to the present invention.

25 Figure 2 shows a front perspective view of a primary filter used in the dual filter system of the vacuum cleaner of Figure 1.

Figure 3 shows a rear perspective view of the primary filter shown in Figure 2.

30 Figure 4 shows a side view of the primary filter shown in Figures 2 and 3.

7a

Figure 5 shows a side perspective view of a pre-filter used in the dual filter system of the vacuum cleaner of Figure 1.

Figure 6 shows a bottom view of the pre-filter shown in Figure 5.

5

Figure 7 shows a top view of the pre-filter shown in Figures 5 and 6 and shows an array of filter holes provided in the front surface of the pre-filter.

Figure 8 shows a longitudinal cross-section of the pre-filter shown in Figures 5 to 7.

10

Figure 9 shows a side view of the pre-filter shown in Figures 5 to 8 and shows an array of filter holes provided in all the side surfaces of the pre-filter.

Figure 10 shows an enlarged longitudinal cross-section of a portion of the rim of the pre-filter shown in Figures 5 to 9 and its associated seal element.

15

Figure 11 shows a side perspective view of a portion of the upper surface of a rim of an embodiment of a pre-filter similar to that shown in figures 5 to 10.

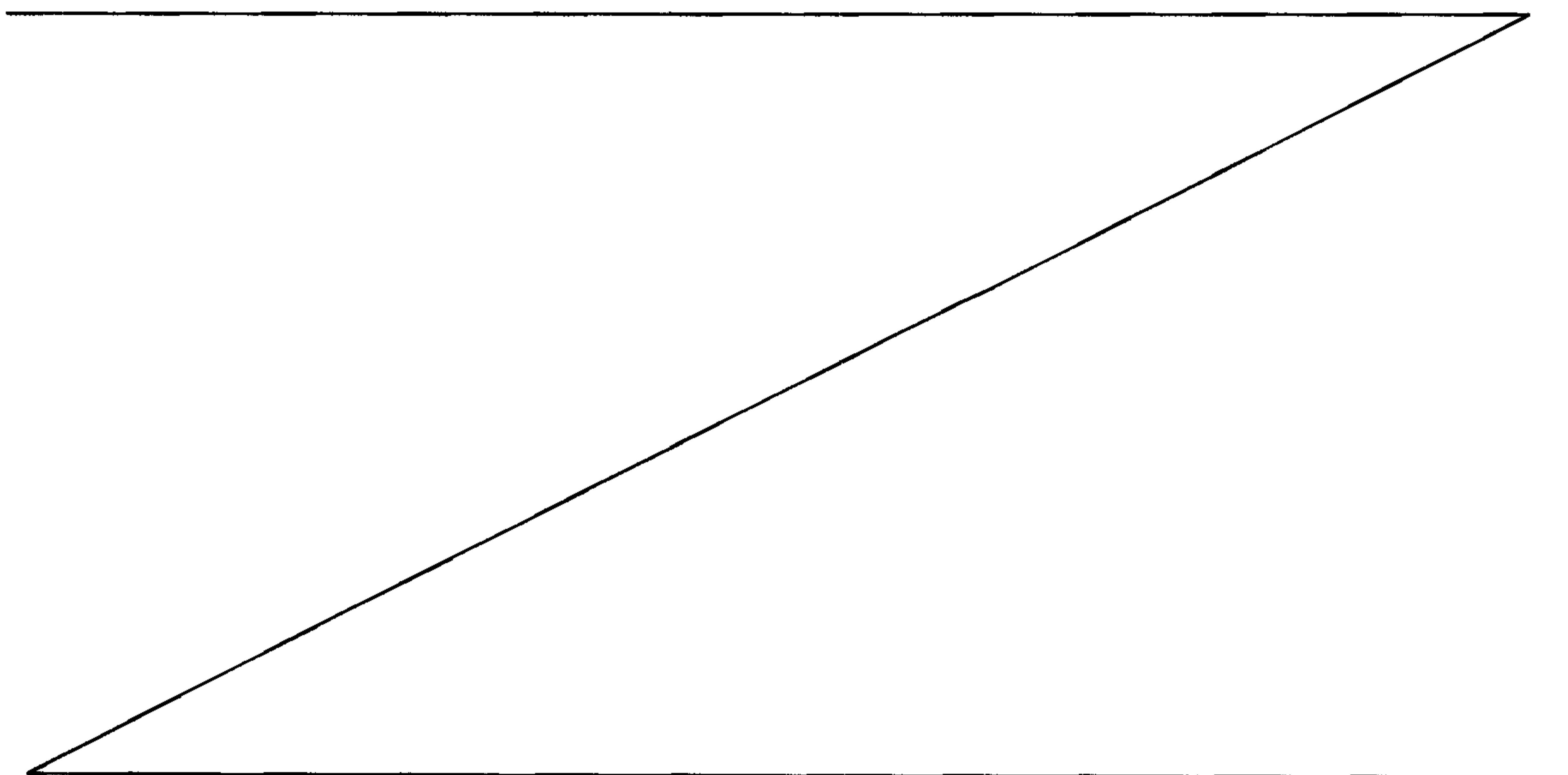

Figure 12 shows a longitudinal cross-section of a portion the nose cone of the vacuum cleaner shown in Figure 1 and an embodiment of a seal element for the rim of the pre-filter shown in Figures 5 to 11.

Figure 13 shows a longitudinal cross-section of a portion the nose cone of the vacuum cleaner similar to that shown in Figure 1 and an embodiment of a seal element for the rim of the pre-filter shown in Figures 5 to 11

The battery powered hand held vacuum cleaner shown in Figure 1 comprises a main housing portion (2) and a nose cone (4) and can be releasably mounted on a charging unit (6) in a known manner. The charging unit (6) can optionally be mounted on a wall for storage and re-charging of the vacuum cleaner.

The main housing portion (2) comprises a handle (8) and houses a motor (10) which is powered by a re-chargeable battery unit (12) also housed within the main housing portion. When the vacuum cleaner is mounted on the charging unit (6) the battery unit (12) is electrically connected to the charging unit to charge the battery unit. For this purpose the charging unit (6) can be connected to a mains electricity supply via an electrical cable (14). The motor (10) is switched on and off by movement of an actuator (16) which is slideably mounted on the main housing portion (2). The actuator (16) operates a switch unit (18) which switches the motor (10) on and off.

The motor (10) rotatingly drives a fan (20). When the fan (20) is rotated by the motor (10) it draws air into it axially from the front of the fan through an inlet (84) provided in the front of the main housing portion (2), as indicated by arrows (A). The fan (20) expels air radially, as indicated by arrows (B). The air expelled by the fan (20) exits the main housing portion (2) via vents (not shown) provided in said housing portion. A dual filter system (34) which comprises a pre-filter (36) and a primary filter (38) is releasably latched onto the front of the main housing portion (2) in front of the inlet (84) to the fan (20) by a pair of pegs (40) which extend from the front of the main housing portion. The pegs (40) have enlarged heads and can be releasably latched within a corresponding pair of keyhole shaped apertures provided in the pre-filter (36) and in the primary filter (38) in a manner described in more detail below.

The nose cone (4) can be releasably fitted onto the main housing portion (2) by the engagement of detent members (22,24) provided on the main housing portion with cooperating recesses (26,28) provided in the nose cone. Detent member (24) can be retracted from recess (28) by depressing a release lever (30) against the force of a biasing spring (32) in order to remove the nose cone (4) from the main housing portion (2). The nose cone (4) comprises an inlet tube (42) for the ingress of dust and debris to be collected by the vacuum cleaner. At the rear end of the inlet tube (42) is provided a deflector (44) for deflecting dust and debris downwardly into a collecting chamber (46) provided in the nose cone (4).

10

In use when the vacuum cleaner is detached from the charging unit (6) and the motor (10) is switched on, the impeller (12) rotates to draw an airflow into the front end (48) of the inlet tube (42), along the inlet tube (42) through the dual filter system (34) and axially into the fan (20). The front end (48) of the inlet tube is directed by a user towards a surface from which dust and/or other debris is to be collected. The airflow generated by the fan (20) entrains dust and debris within it and so this dust and debris is pulled up the inlet tube (42) and a proportion of is deflected downwardly with the airflow by the deflector (36) towards collecting chamber (46). In this way some of the dust and debris entrained in the airflow will be removed from the airflow and collected within the collecting chamber (46). The remainder of the dust and debris entrained within the airflow will be separated from the airflow by the dual filter system (34). The proportion of dust and debris separated from the airflow by the pre-filter (36) will drop downwardly, due to gravity, and will be collected in the collecting chamber (46). The remaining, relatively small, proportion of the dust and debris separated from the airflow by the primary filter (38) will be collected in the space between the pre-filter (36) and the primary filter (38).

When a user has collected a pre-determined amount of dust and debris or has completed a debris collecting task, the motor (10) will be switched off and the nose cone (4) removed from the main housing portion (2) by depressing the release lever (30). The dust and debris contained in the collecting chamber (46) can then be disposed of. Also the dual filter system (36) can be removed as required by the

30

operator from the main housing portion (2) and any dust or debris collected on or between the pre-filter (36) and the primary filter (38) can be removed. The dual filter system (34) and nose cone (4) can then be re-fitted onto the main housing portion (2) and the vacuum cleaner is ready for further use or can be stored away for subsequent  
5 use.

One of the benefits of the arrangement utilising a dual filter attached to the main housing portion (2) is that this design provides for relative ease of emptying and cleaning the vacuum cleaner. In particular, the user may hold the housing unit in one  
10 hand whilst removing the collecting chamber (26) with an opposed hand, the dust and debris being primarily retained within the collecting chamber (46) and thus can be emptied at the operator's convenience. No additional step is required to remove the pre- or primary filters from the main housing and any debris collected between the primary filter and the pre-filter can simply be removed by vibrating or shaking the  
15 housing unit with the filters attached thereto. This enables a continuous operation to empty the vacuum cleaner.

The dual filter system (36) will now be described in more detail, with reference to  
Figures 1 to 13.

20

The primary filter (38) of the dual filter system (34) shown in Figure 1 comprises a moulded plastic frame within which is supported a concertina of woven polyester filter material (50). The moulded plastic frame comprises a rim (52) from which extend two opposing side support frames (54, 56). Each side support frame (54, 56)  
25 comprises an outer frame (60a, 60b, 60c) within which are formed an array of lower forked support arms (58a) and an array of upper forked support arms (58b) which co-operate in a zig-zag formation. The concertina of filter material (50) is supported between the zig-zag formation of opposing support arms (58a, 58b) and by the end support arms (60a, 60c) of the outer frame. In addition triangular shaped sections of  
30 woven polyester filter material (62) are supported between adjacent support arms (58a), adjacent support arms (58b), adjacent support arms (60a, 58a) and adjacent support arms (60c, 58a). The triangular sections of filter material (62) provide a side

filter surface across the area contained within the outer frame (60a,60b,60c) of each support frame (54, 56).

The primary filter (38) is manufactured by folding a concertina of filter material (50) within and locating triangular sections of filter material (62) appropriately within a moulding die and then injecting plastics material into the moulding die to form the moulded plastics frame comprising rim (52) and opposing support frames (54,56). The opposing support frames will thus support the woven filter material (50, 62) securely in position. The folding of the filter material (50) in the concertina arrangement and the additional triangular sections of filter material (62) provides a primary filter (38) with a relatively large cross-sectional area.

The rim (52) of the primary filter (38) has formed within it on opposing sides keyhole shaped apertures (64,66), which are used to releasably latch the primary filter (38) to co-operating pegs (40) provided on the front of the main housing portion (2) of the vacuum cleaner of Figure 1.

As shown in Figure 1, in use the primary filter (38) will be surrounded by a pre-filter (36) shown in Figures 5 to 9. The pre-filter (36) comprises a moulded plastic open box-shaped casing having front surface (66) and four side surfaces (68a to 68d) and a rim (70). A resilient seal element (72) extends around the periphery of the rim (70). The front surface (66) and the four side surfaces each have formed through them an array (74) of circular filter holes, for example the array of filter holes (74a) formed in the front surface (66) as shown in Figure 7 and the array of filter holes (74b) formed in the side surface (68b) as shown in Figure 9. Each of the holes in the arrays of holes (74) has a diameter of approximately 1mm although the size may vary, if required between 0.75mm and 1.75mm. The arrays of holes in the pre-filter (36) provide a first coarse filtering stage in front of the primary filter which provides a second fine filtering stage.

30

To aid in the injection moulding of the pre-filter (36) the front face (66) of the pre-filter comprises a solid circular region (76) from which extend radially outwardly six

solid arms (78). The solid circular region (76) and arms (78) assist in the flow of molten plastics material during the injection moulding process, which flow would otherwise be impaired by narrow channels between the holes forming the arrays of holes (74). The solid circular region (76) also provides a region of the pre-filter (36) that can prominently display information such as trade marks.

It has been found in practice that the 1mm diameter size of the holes in the pre-filter (36) is generally greater than the majority of the particles of dust and debris entering the nose cone (4) in use of the vacuum cleaner shown in Figure 1. However, the pre-filter (36) still deflects the majority of particles of dust and debris, irrespective of their size, out of the airflow drawn through the pre-filter (36) by the fan (20). These deflected particles of dust and debris are collected in the collecting chamber (46) of the nose cone (4). Up to 90% of particles of debris and dust normally picked up during household vacuuming and entrained in the airflow in front of the pre-filter (36) can be removed from that airflow by the pre-filter. However, the amount of particulate removed from the airflow is dependent on the size of that particulate.

The 1mm diameter circular hole size used in the pre-filter would be expected not to deflect the generally much smaller sized particles of dust and debris entrained in an airflow through it. However, when the particles of dust and debris entrained within the airflow hit the front surface of the pre-filter (36) the momentum of the particles is reduced or eliminated. The airflow into the pre-filter (36) is often insufficient to then recapture such particles and these particles fall into the collecting chamber (46). This significantly reduces the volume of particles of dust and debris which reach the primary filter (38) and so there is a significant reduction in the amount of blocking of the pores of the filter material used therein by conglomerations of such particles. Furthermore, as the particles that reach the primary filter (38) will have passed through the 1mm diameter holes in the pre-filter (36) they will be of more uniform diameter than if the pre-filter was not used. It has been found that this increased level of uniformity of diameter of particles incident on the filter material (50, 62) of the primary filter (36) is more resistant to binding and thus tends to reduce further the blocking up of the pores in the primary filter by conglomerations of particles. This is

because particles of similar diameter are less likely to bind together to form a conglomerated mass that could block the filter material than particles of dissimilar diameters. The more uniform diameter particles that have passed through the pre-filter (36) tend not to bind and instead fall away from the filter material (50, 62) into the space between the pre-filter (36) and the primary filter (38). This reduction of blocking of the pores of the primary filter improves the suction of the vacuum cleaner during use as the airflow to the fan (20) is not impeded by a blocked primary filter (38).

10 In a similar way to the primary filter (38), the rim (70) of the pre-filter (36) has formed within it on opposing sides keyhole shaped apertures (80, 82), which are used to releasably latch the pre-filter (38) to co-operating pegs (40) provided on the front of the main housing portion (2) of the vacuum cleaner of Figure 1. When the primary filter (38) is received within the pre-filter (36), the keyhole shaped apertures (64, 80) and (66, 82) line up so that the dual filter system (34) comprising the pre-filter (36) and the primary filter (38) can be releasably latched to the main housing portion (2) as a single assembly.

To fit the dual filter system (34) to the main housing portion (2), the widened portions of the keyhole shaped apertures (64, 80) and (66, 82) are fitted over the enlarged head of a corresponding one of the pair of pegs (40). The dual filter system (34) is then rotated slightly to slide the stem of the pegs (40) into the narrow portion of the respective keyhole shaped apertures (64, 80) and (66, 82) in order to securely latch the dual filter system (34) to the main housing portion (2) over the inlet (84) to the fan (20). One of the pegs (40) comprising an enlarged head (86) and a stem (88) is shown clearly in dotted lines in Figure 10.

Figure 10 shows in more detail the resilient seal element (72) which surrounds the rim (70) of the pre-filter (36). The seal element (72) is made of a resilient material such as rubber, silicone, neoprene or other suitable elastomers and is intended to form an air tight seal between the pre-filter (36) and the primary filter (48), between the dual

filter system (34) and the nose cone (4) and between the dual filter system and the main housing portion (2).

The rim (70) has a stepped portion (90) which extends around its periphery and the resilient seal element (72) is moulded over this stepped portion. The seal element (72) comprises a radially outwardly extending portion (92), which as seen in Figure 1 engages the inner surface of the wall of the nose cone (4), when the nose cone is fitted to the main housing portion (2), to form an airtight seal between the dual filter system (34) and the nose cone. The seal element also comprises a first axially rearwardly extending portion (94) (Figure 10) which extends around the periphery of the rim (52) of the primary filter (38) to engage a forward surface of the main housing portion (2) to form an airtight seal between the dual filter system (34) and the main housing portion, and as a consequence an airtight seal is also formed between the pre-filter (36) and the primary filter (38). The seal element (72) further comprises a second axially rearwardly extending portion (96) against which the rim (52) of the primary filter (38) abuts when the pre-filter (36) and primary filter (38) are together fitted onto the main housing portion. This provides further air tight sealing between the pre-filter (36) and primary filter (38). This sealing is further enhanced by extending the seal element (72) at the keyhole shaped apertures (80,82) so that an extension (98) (See also Figure 6) of the seal element extends around each keyhole shaped aperture (80, 82) partly within a recess (100) formed in the lower side of the rim (70) around said apertures.

Thus, when the dual filter arrangement (34) is assembled and fitted onto the main housing portion (2) the primary filter (38) is inserted into the pre-filter (38) such that the concertina of filter material (50) is received within the box-shaped cavity of the pre-filter, the keyhole shaped apertures (64, 80) and (66, 82) are aligned, the second axially extending portion (96) of the seal (72) abuts the rim (52) of the primary filter (38) and the first axially extending portion (94) of the seal (72) extends around the periphery of the rim (52) of the primary filter (38). The dual filter arrangement is then latched onto the studs (40) provided on the main housing portion (2). This latching of the dual filter system (34) to the pegs (40) presses the rims (52, 70) of the filters

together and so reinforces the seal between the pre-filter (36) and primary filter (38) provided by the portion (96) of the seal element (72). It also presses the rim (70) of the pre-filter (36) towards the front surface of the main housing portion (2) and so reinforces the seal between the pre-filter and the main housing portion provided by the  
5 portion (94) of the seal element (72).

An alternative design of pre-filter (38) which provides an improved releasable latch connection between the dual filter system (34) and the main housing unit (2) of the vacuum cleaner of Figure 1 is shown in Figure 11. In the arrangement of Figure 11, a  
10 raised cam surface (102) is provided on the upper surface of the rim (70) of the pre-filter (38) bordering the narrow portion and part of the widened portion of each keyhole shaped aperture (80, 82). Each cam surface (102) comprises a pair of ramps (104) facing towards the widened end of the aperture it borders and an opposing pair of ramps (106) facing towards the narrow end of the aperture it borders. Each cam  
15 surface (102) co-operates with the underside of the enlarged head portion (86) of a respective peg (40). When the dual filter system (34) is fitted over the pair of pegs (40) provided on the main housing portion (2), the enlarged head portion (86) passes through the widened portion of the respective key shaped apertures (64, 80) and (66, 82). Then the dual filter system (34) is rotated by a small amount so that the neck  
20 portion of each peg (40) slides into the narrow portion of the respective apertures and the enlarged head portion (86) of each peg latches the dual filter system into the main housing portion.

With the improved arrangement shown in Figure 11, rotation of the dual filter system  
25 (34) in this way, causes the underside of the enlarged head (86) of each peg to ride up the pair of ramps (104) on the respective cam surface (102). This urges the rim (70) of the pre-filter (36) towards the main housing portion (2) and thus towards the rim (52) of the primary filter (38) against the biasing force of the axially extending portions (94, 96) of the seal element (72). Further rotation of the dual filter system  
30 causes the underside of the enlarged head (84) of each peg to move down the opposing ramps (106) and come to rest in its final latched position against the flat raised portion of the cam surface (102) surrounding the narrowed portion of each

aperture (80, 82). This slightly releases the compression of the axially extending portions (94, 96) of the seal element (72). However, with the dual filter system in its latched position, the rim (70) of the pre-filter system is urged sufficiently towards the main housing portion (2) and towards the rim (52) of the primary filter (36) for the axially extending portions (94, 96) to form an air tight seal against the main housing portion and the rim (52) respectively. This ensures that in use of the vacuum cleaner all airflow to the fan (20) passes through the pre-filter (36) and through the primary filter (38). Furthermore, the two ridges (108) on each cam surface (102) between the opposing ramps (104, 106) serve as a retaining means to retain the pegs (40) in their latched position against the resilience of the axially extending portions (94, 96) of the sealing element (72). In this way the dual filter system can only be unlatched from the pegs (40) by rotation in a direction opposite to that required to latch the dual filter system to the pegs, which rotation can only occur if a force is applied which is sufficient to compress the axially extending portions (94, 96) so that the underside of the enlarged heads (86) of the pegs (40) can ride over the ridges (108) in the cam surfaces (102).

Alternatively, or in conjunction with the use of the cam surfaces (102), internal ribs may be provided around the interior surface of the collecting chamber (46) so as the collecting chamber (46) is moved into engagement with the main housing portion (2), these ribs engage with the rim (70) of the pre-filter system so as to serve to compress the axially extending portions (94, 96) of the sealed element (72) into respective engagement with the housing portion (2) and primary filter (36) accordingly. The use of ribs in this manner will provide a uniformly distributed compression force about the entire periphery of the seal of the pre-filter.

Figure 13 shows a cross-section of the seal element (72) shown in Figure 10, with like parts identified by like numerals. Figure 13 also shows a modified portion of the outer wall of the nose cone (4) adjacent the seal element (72) from that shown in Figure 1. In the Figure 13 embodiment an internal raised wall (110) extends around the portion of the internal surface of the nose cone (4) which surrounds the seal element (72). This creates an improved air tight seal between the dual filter system

(34) and the inner surface of the nose cone (4). The radially extending portion (92) of the resilient seal element (72) abuts the rear surface of the wall (110). In use of the vacuum cleaner the underpressure created in the forward part (112) of the nose cone (4) relative to the ambient air pressure in the region (114) in front of the main housing portion (2) reinforces a sealing engagement between the portion (92) of the sealing element (72) and the wall (110). The pressure differential urges the front surface of the resilient radially extending portion (92) of the seal element (72) into sealing engagement with the rear surface of the wall (110). Again this ensures that all the airflow through the nose cone (4) passes through the dual filter arrangement (34) into the fan (20).

Figure 12 shows an alternative embodiment to that shown in Figure 13, with like parts identified by like numerals, in which the wall (110) is not required on the internal surface of the nose cone (4) and the radially extending portion (92) of the seal element (72) is bent rearwardly to form a third axially rearwardly extending portion (116). In Figure 12 the radially extending portion (92) is bent rearwardly through approximately 90°. Thus, as shown in solid lines in Figure 12, when the nose cone (4) is fitted on the main housing unit (2) with the vacuum cleaner switched off, there is no sealing engagement between the seal element (72) and the nose cone (4). However, when the vacuum cleaner is switched on the pressure differential between the underpressure created in the region (112) of the nose cone (4) and the ambient pressure in the region (114) causes the third resilient axially extending portion (116) to move outwardly into the position showed in Figure 12 in dotted lines and into a sealing engagement with the internal surface of the wall of the nose cone (4). Thus, when the vacuum is in use a seal is provided between the dual filter system (34) and the nose cone (4) to ensure that all the airflow through the nose cone passes through the dual filter system. However, when the vacuum cleaner is not in use the lack of engagement between the seal element (72) and the nose cone (4) can help to prevent wear of the portion (116) of the seal element due to the repeated removal and replacement of the nose cone (4) during the lifetime of the vacuum cleaner.

**Claims:**

- 1. A concertina filter arrangement for a vacuum cleaner for filtering particles of dust and debris from airflow passing through the vacuum cleaner, comprising a frame and a concertina shaped arrangement of filter material supported and maintained by the frame, wherein the frame comprises opposing array of arms forming a substantially zigzag formation such that the filter material is supported by said opposing array of arras, wherein additional pieces of fine filter material are located between adjacent arms of the array of arms.**
- 2. A concertina filter arrangement according to claim 1, wherein the frame additionally comprises a peripheral rim via which it can be releasably fitted to a housing portion of a vacuum cleaner.**
- 3. A concertina filter arrangement according claim 1 or claim 2, wherein the frame of the filter comprises a moulded plastics material**
- 4. A vacuum cleaner comprising a filter arrangement according to any one of claims 1 to 3.**
- 5. A battery powered hand held vacuum cleaner according to claim 4 comprising a first housing portion which houses a battery pack, a motor and a fan and a second housing portion which comprises a nose cone, wherein the battery pack powers the motor which rotatingly drives the fan to generate an airflow which enters the vacuum cleaner through the nose cone and passes through the filter arrangement into the fan.**

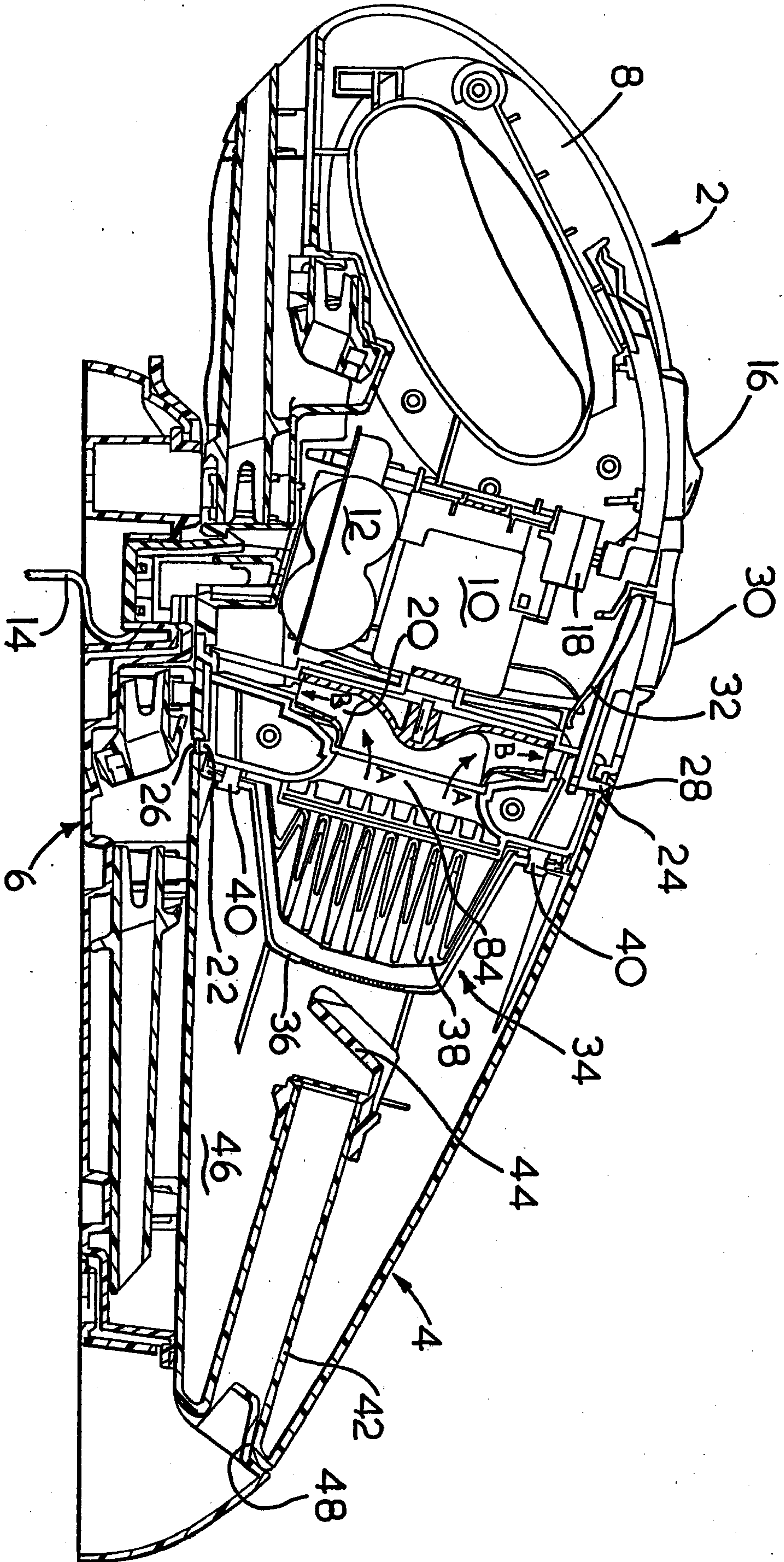

FIG. 1



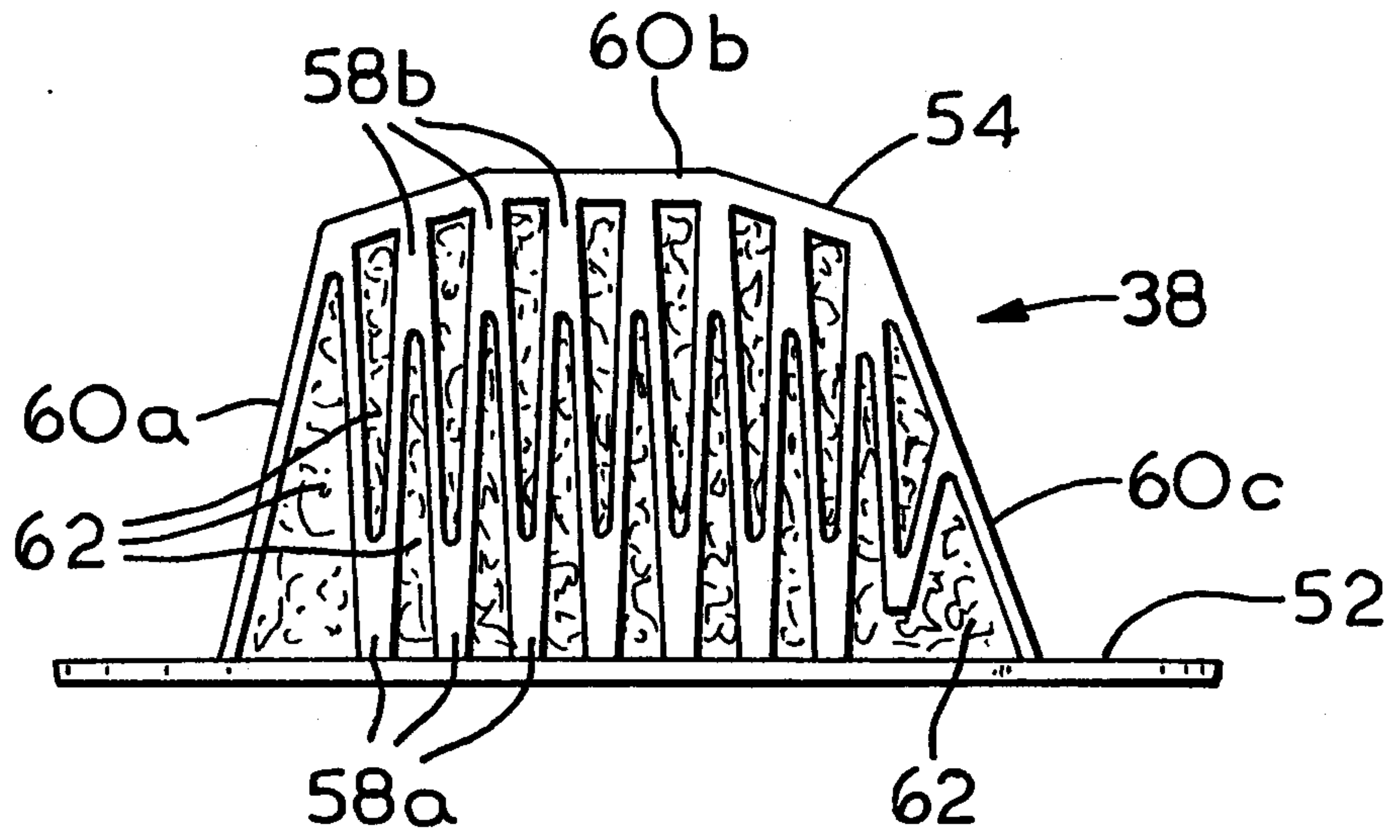

FIG. 4

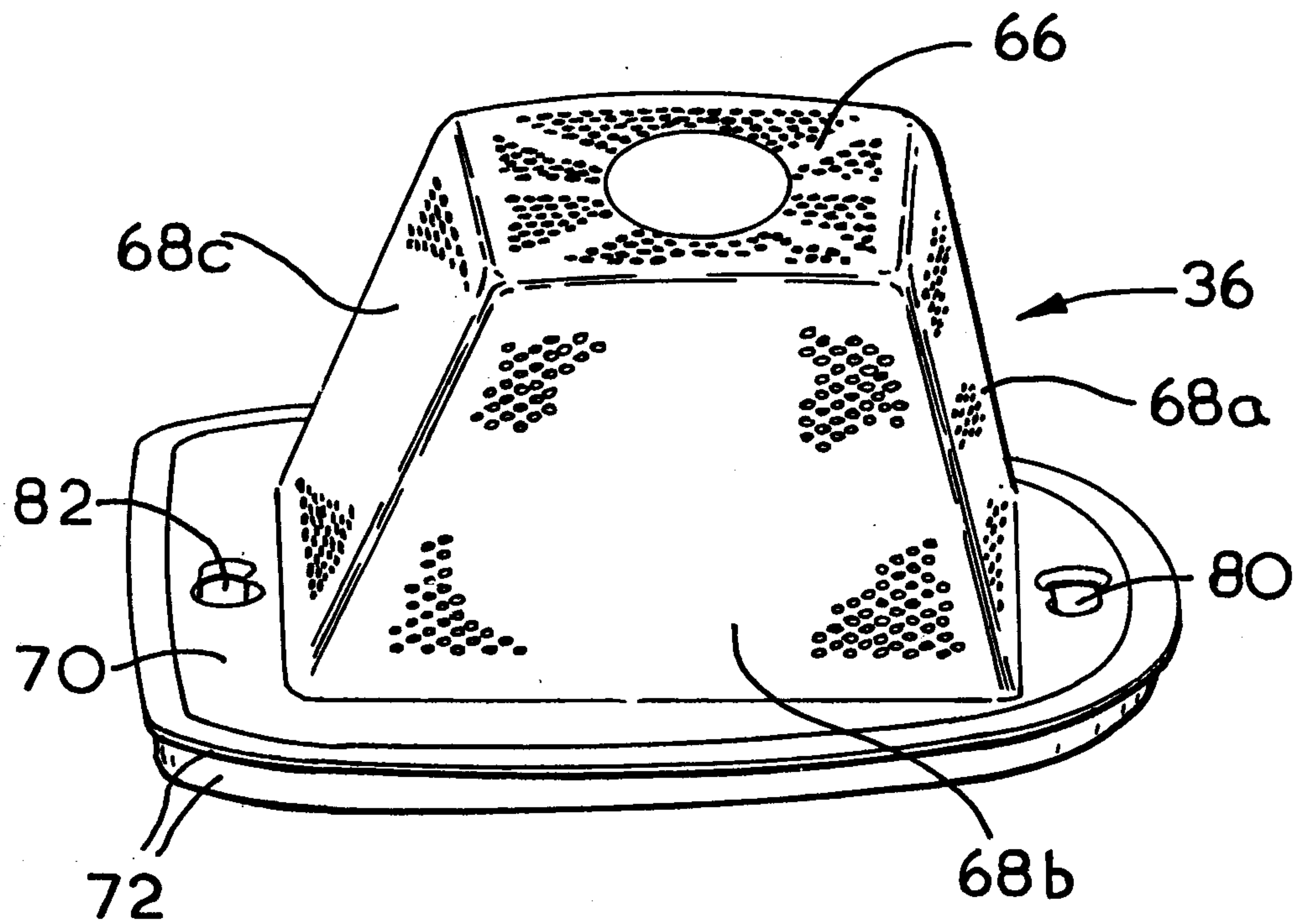

FIG. 5

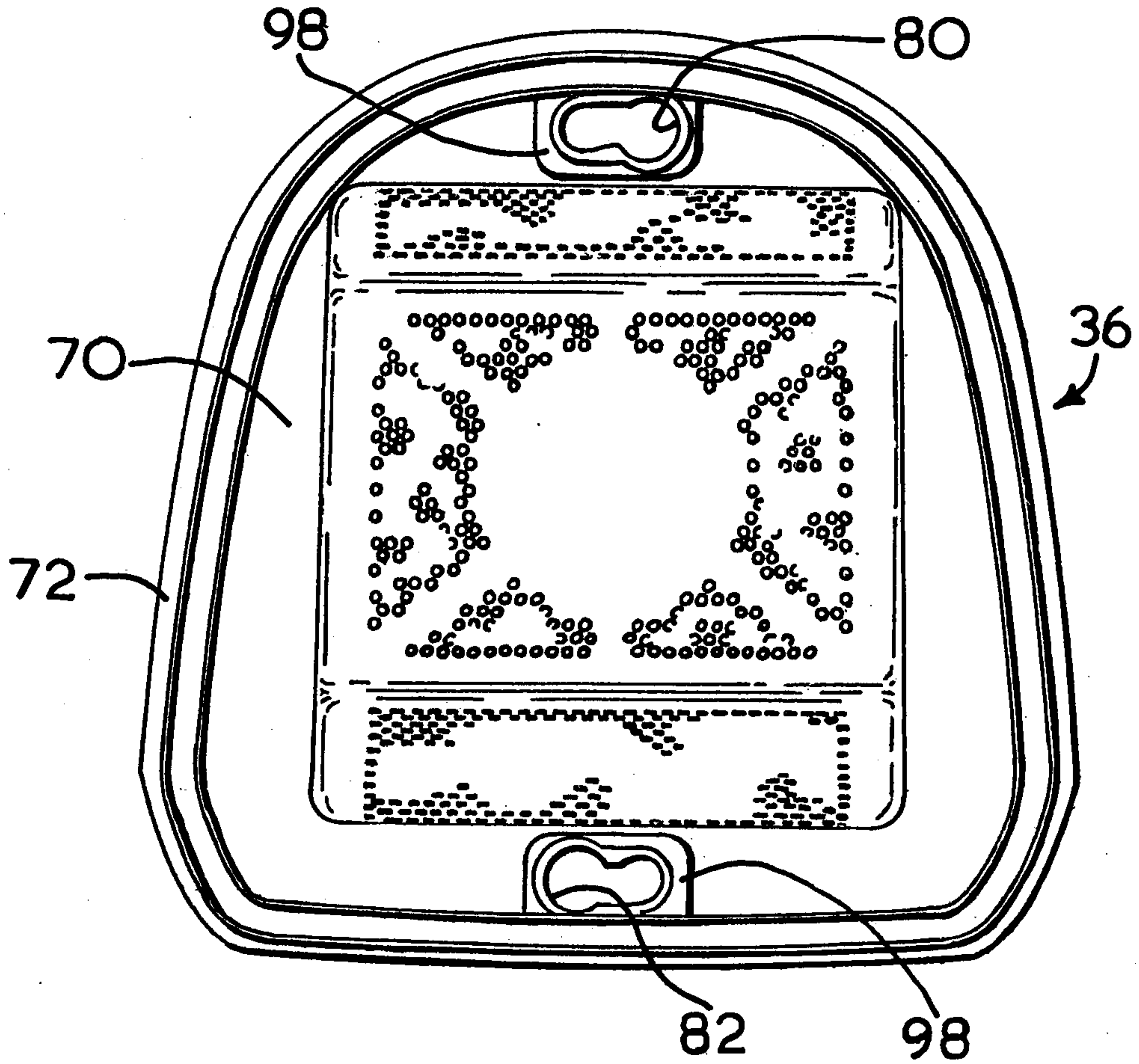

FIG. 6

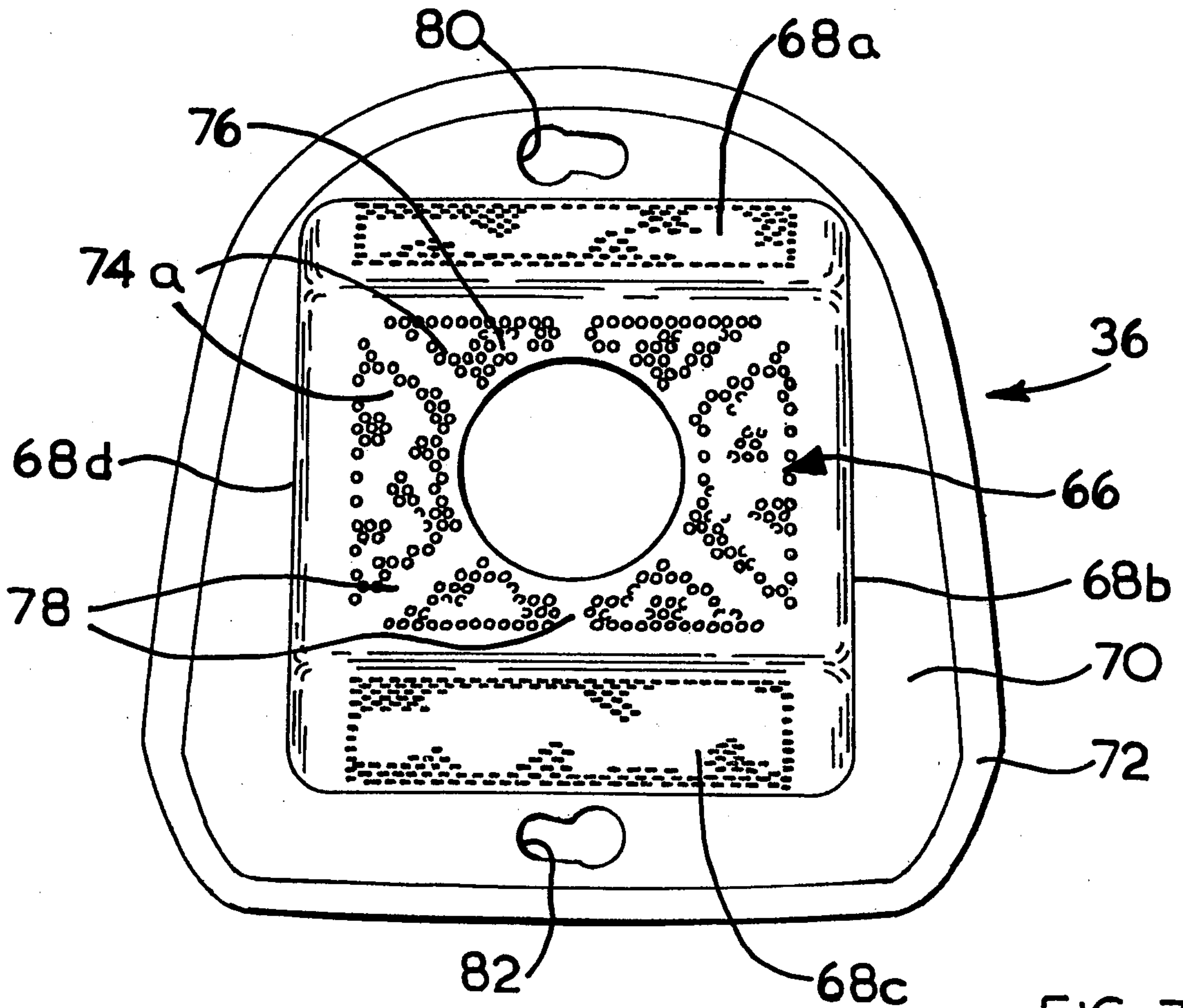

FIG. 7

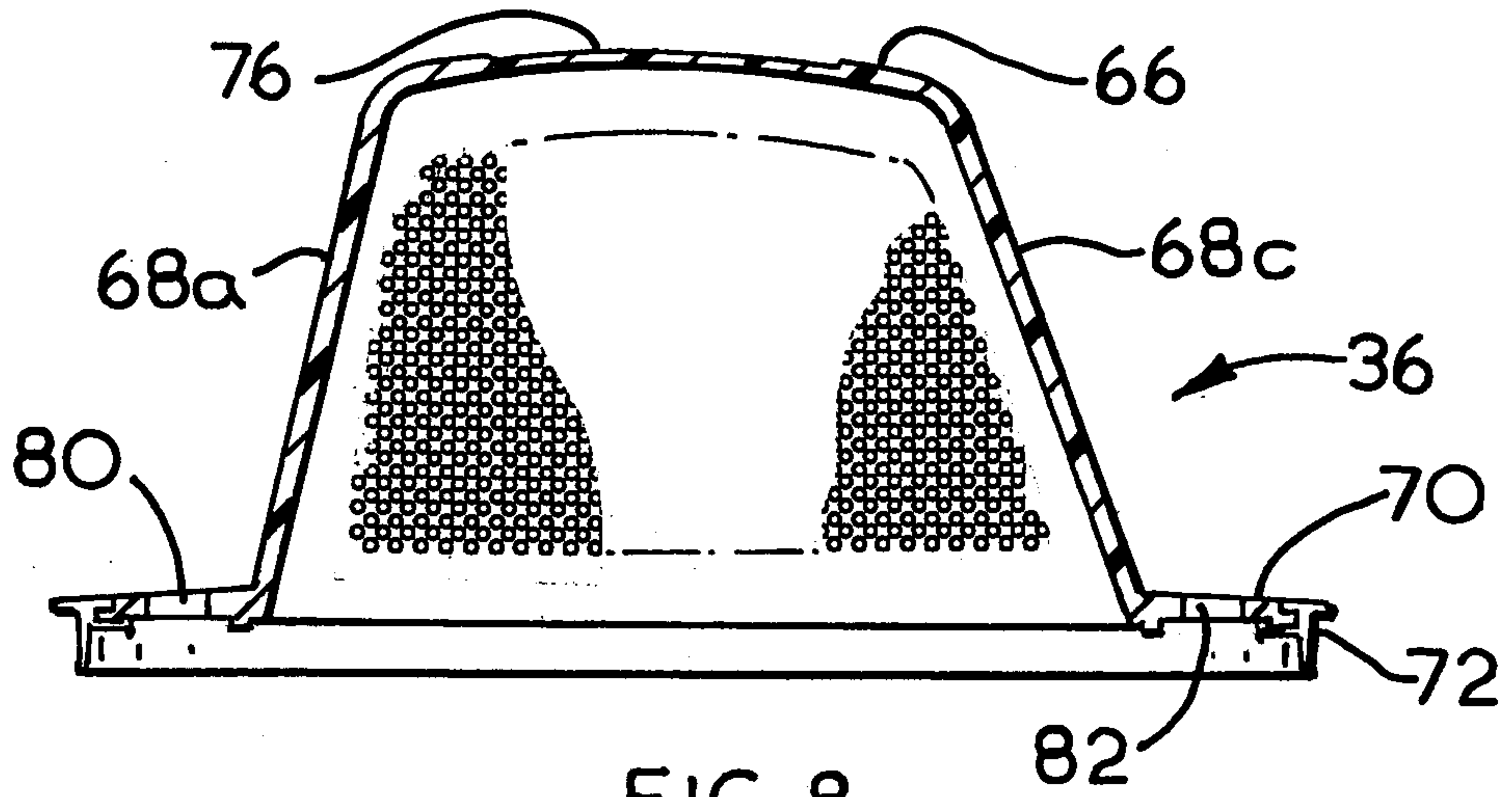

FIG. 8

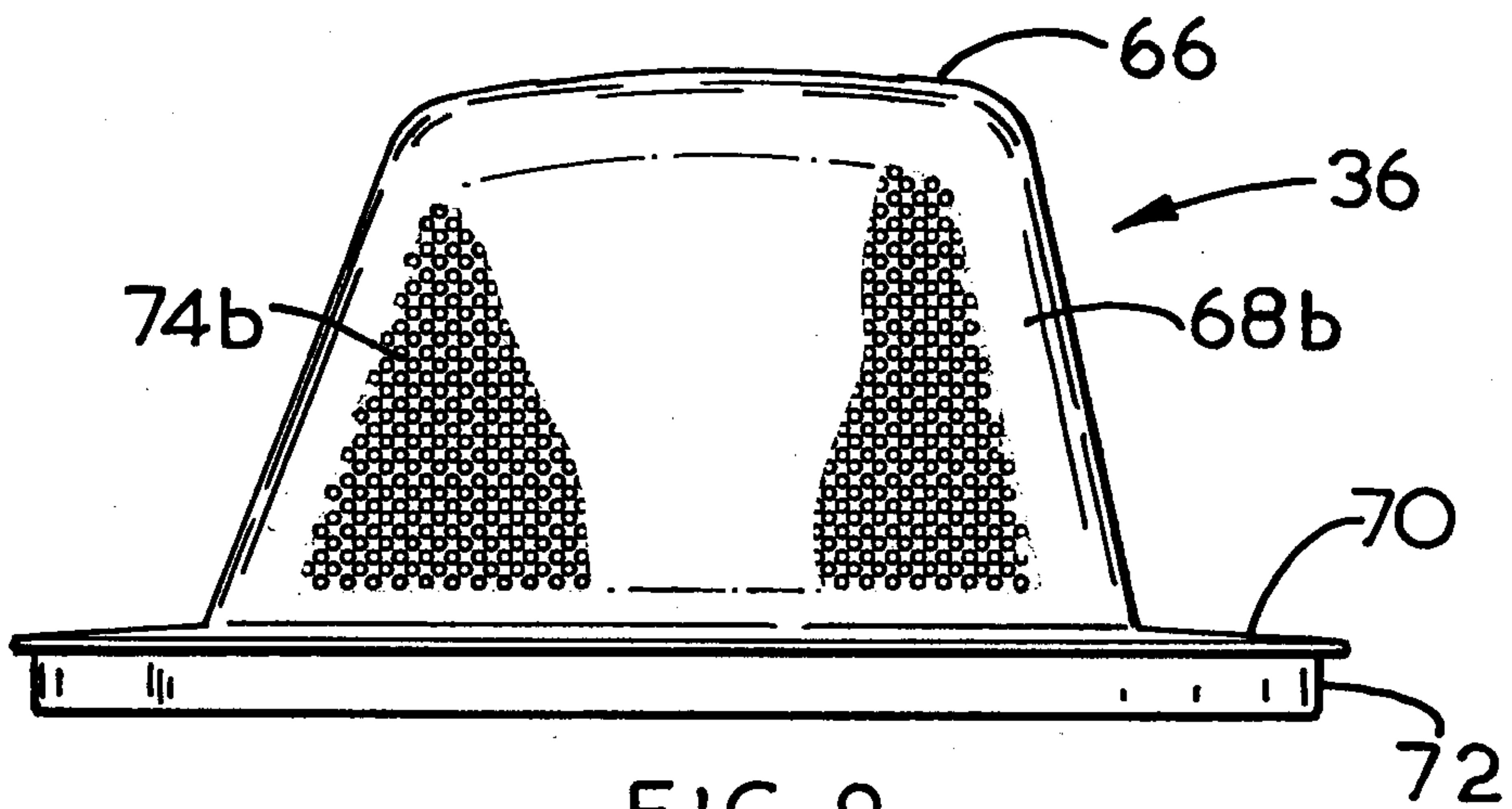

FIG. 9

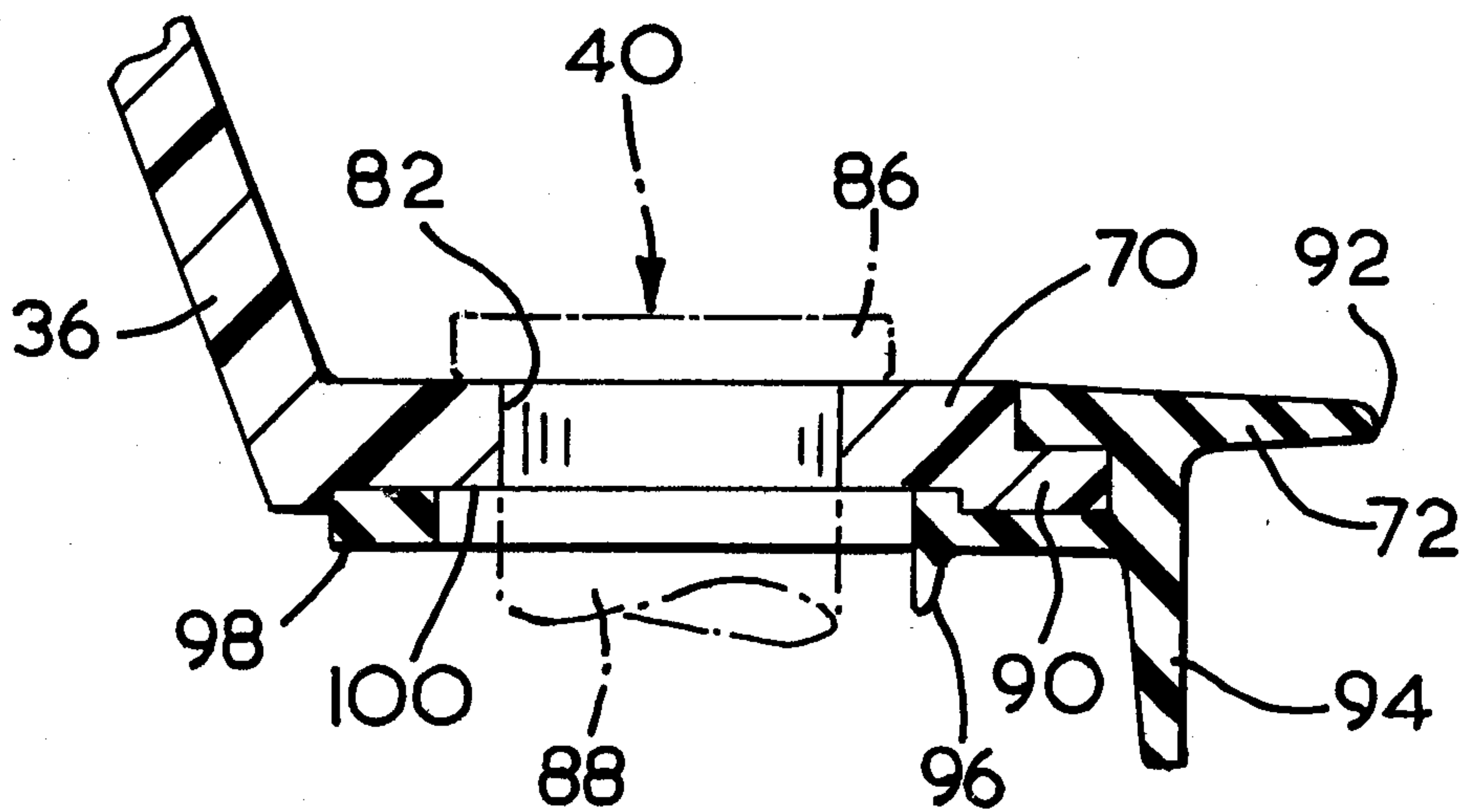

FIG. 10

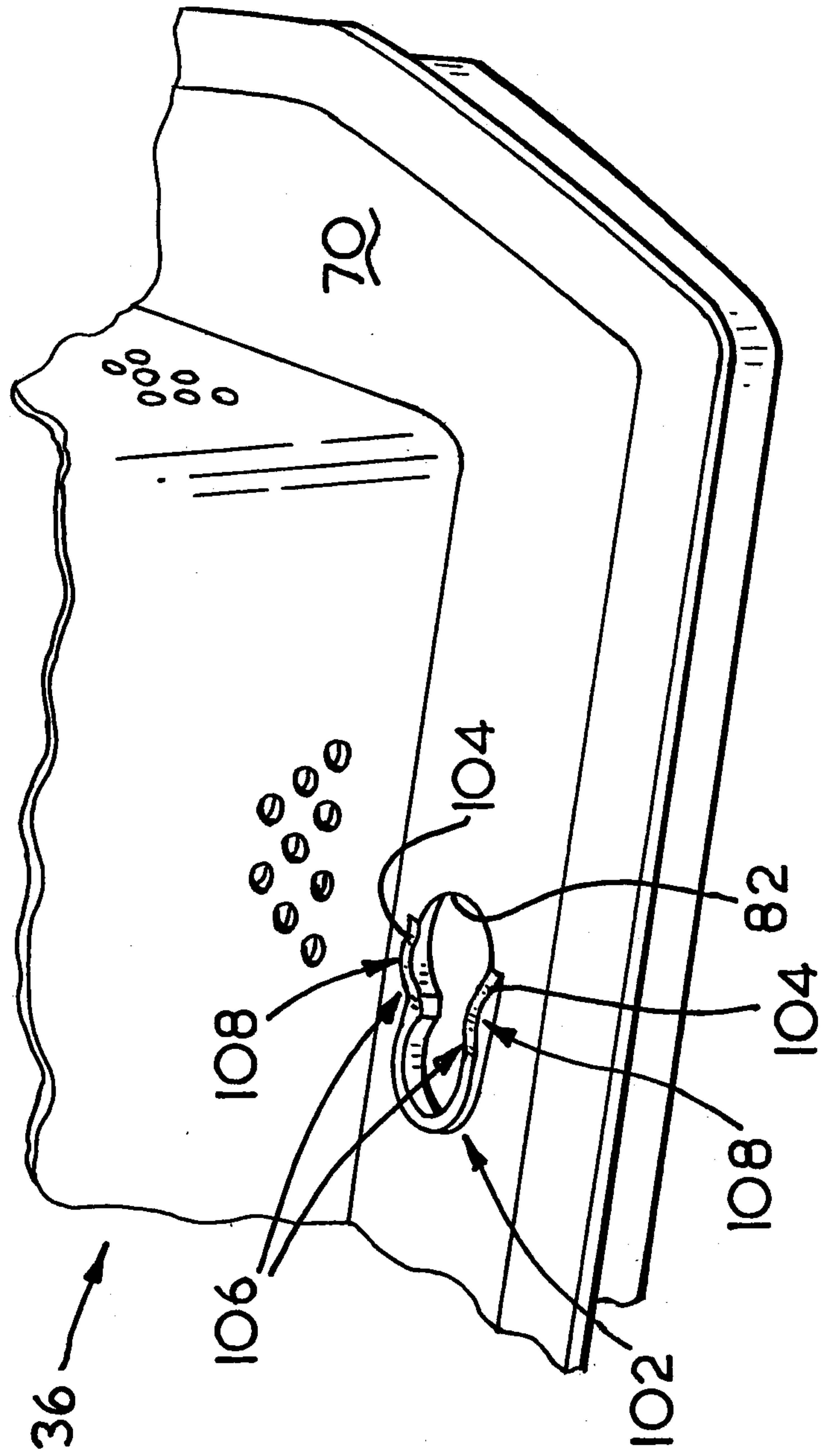

FIG. II

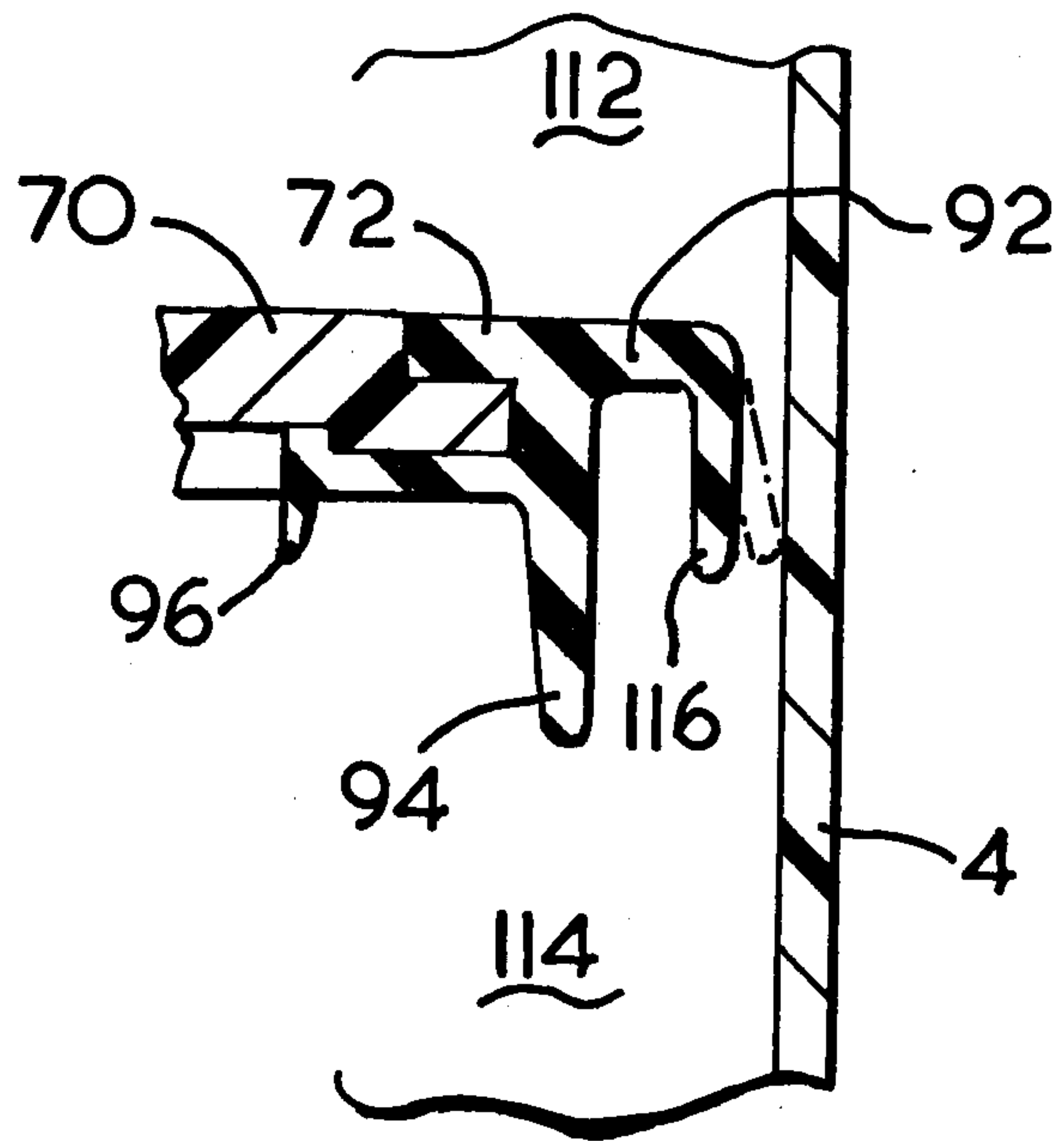

FIG. 12

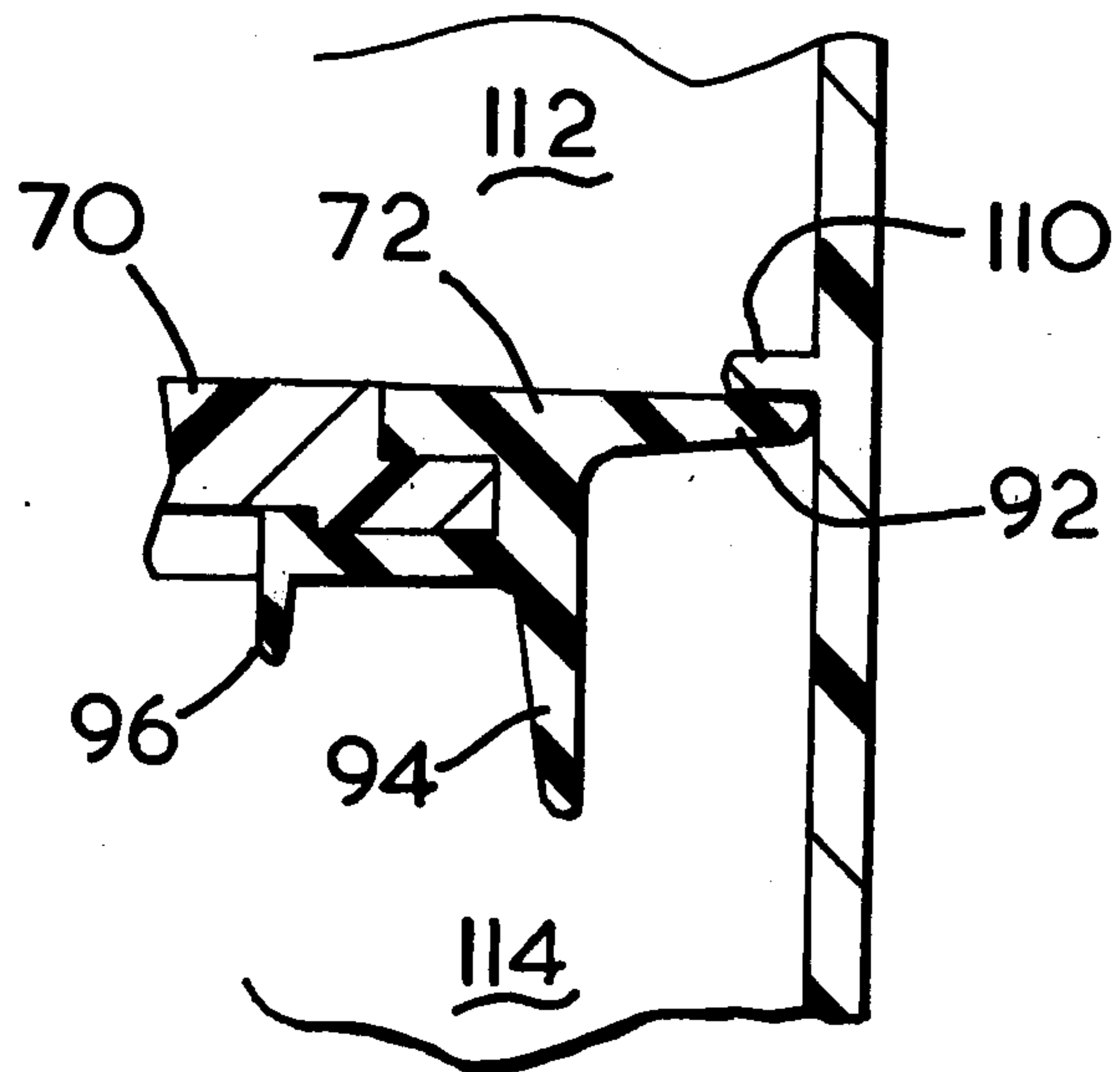

FIG. 13

