



(12) **United States Design Patent**
Heine et al.

(10) **Patent No.:** **US D1,036,209 S**
(45) **Date of Patent:** **** Jul. 23, 2024**

- (54) **LOPPER**
- (71) Applicant: **Fiskars Finland Oy Ab**, Espoo (FI)
- (72) Inventors: **Mikko Heine**, Espoo (FI); **Petteri Masalin**, Espoo (FI)
- (73) Assignee: **Fiskars Finland Oy Ab**, Espoo (FI)
- (**) Term: **15 Years**
- (21) Appl. No.: **29/837,102**
- (22) Filed: **May 2, 2022**

| | | | | | | |
|----------|---|---|---------|-------------|-------|------|
| D494,027 | S | * | 8/2004 | Lin | | D8/5 |
| D510,002 | S | * | 9/2005 | Lai | | D8/5 |
| D606,816 | S | * | 12/2009 | Deville | | D8/5 |
| D646,534 | S | * | 10/2011 | Deville | | D8/5 |
| D684,828 | S | * | 6/2013 | Masalin | | D8/5 |
| D691,004 | S | * | 10/2013 | Masalin | | D8/4 |
| D691,434 | S | * | 10/2013 | Nies | | D8/5 |
| D691,435 | S | * | 10/2013 | Nies | | D8/5 |
| D691,436 | S | * | 10/2013 | Nies | | D8/5 |
| D693,192 | S | * | 11/2013 | Masalin | | D8/5 |
| D704,520 | S | * | 5/2014 | Lyytikainen | | D8/5 |
| D715,607 | S | * | 10/2014 | Lyytikainen | | D8/5 |

(Continued)

(30) **Foreign Application Priority Data**

Nov. 8, 2021 (EM) 008753321-0003

(51) **LOC (14) Cl.** **08-01**

(52) **U.S. Cl.**
USPC **D8/4**

(58) **Field of Classification Search**
USPC ... D8/1, 4, 5, 10, 51, 52, 53, 54, 55, 56, 58,
D8/105, 107
CPC B26B 13/00; B26B 13/06; B26B 13/08;
B26B 13/12; B26B 13/14; B26B 13/16;
B26B 13/20; B26B 13/26; B26B 13/28;
B26B 17/00; A01G 3/00; A01G 3/02;
A01G 3/021; A01G 3/025; A01G 3/0251;
A01G 3/0475

See application file for complete search history.

(56) **References Cited**

U.S. PATENT DOCUMENTS

| | | | | | | |
|-----------|---|---|---------|---------|-------|-----------------------|
| D344,218 | S | * | 2/1994 | Wensley | | D8/5 |
| D344,219 | S | * | 2/1994 | Wensley | | D8/5 |
| 5,511,314 | A | * | 4/1996 | Huang | | A01G 3/0251 30/249 |
| 5,839,195 | A | * | 11/1998 | Lin | | A01G 3/0251 30/249 |
| D464,855 | S | * | 10/2002 | Clivio | | D8/5 |

OTHER PUBLICATIONS

Corona Dual Link Metal Pro Lopper, Apr. 27, 2022 [online],
[retrieved Nov. 20, 2023]. Retrieved from internet, <https://www.lowes.com/pd/Corona-Corona-Dual-Link-Metal-Pro-Lopper/5005413993> (Year: 2022).*

(Continued)

Primary Examiner — Eric L Goodman
Assistant Examiner — Adrian A Shwaiko
(74) *Attorney, Agent, or Firm* — Leason Ellis LLP

(57) **CLAIM**

The ornamental design for a lopper, as shown and described.

DESCRIPTION

FIG. 1 is a left-side perspective view of a lopper according to our new design;
FIG. 2 is right-side perspective view thereof;
FIG. 3 is a front elevation view thereof;
FIG. 4 is a right-side elevation view thereof;
FIG. 5 is a left-side elevation view thereof; and,
FIG. 6 is a top plan view thereof.

The broken lines showing of portions of the lopper are included for the purpose of illustrating environmental structure and form no part of the claimed design.

1 Claim, 6 Drawing Sheets

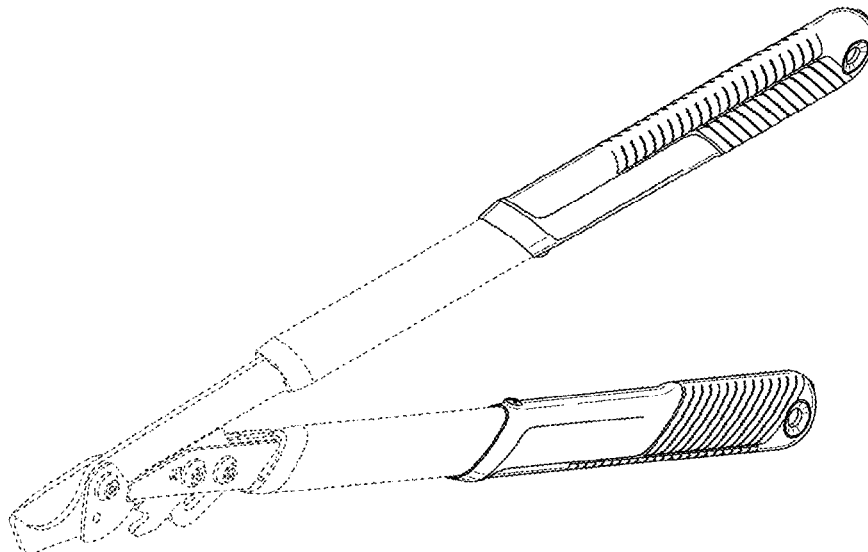

(56)

References Cited

U.S. PATENT DOCUMENTS

D717,133 S * 11/2014 Lyytikainen D8/5
 D717,134 S * 11/2014 Lyytikainen D8/5
 D802,384 S * 11/2017 Wolf D8/4
 D813,620 S * 3/2018 Janson D8/5
 D846,364 S * 4/2019 Candaux D8/5
 D847,590 S * 5/2019 Janson D8/5
 D859,101 S * 9/2019 Wu D8/5
 D890,582 S * 7/2020 Roberts D8/1
 D890,584 S * 7/2020 Roberts D8/4
 2011/0203117 A1* 8/2011 Huang A01G 3/0251
 30/267
 2012/0151781 A1* 6/2012 Huang A01G 3/0251
 30/251
 2012/0186087 A1* 7/2012 Huang A01G 3/0251
 30/252
 2013/0047442 A1* 2/2013 Wu A01G 3/0251
 30/260

2014/0215834 A1* 8/2014 Wang A01G 3/021
 30/251
 2015/0237809 A1* 8/2015 Lin A01G 3/0251
 30/252
 2016/0120132 A1* 5/2016 Hsu A01G 3/021
 30/251
 2022/0304242 A1* 9/2022 Heine A01G 3/0251

OTHER PUBLICATIONS

Fiskars Ultrasharp 7.5-in Steel Bypass Lopper, Mar. 15, 2020 [online], [retrieved Nov. 20, 2023]. Retrieved from internet, <https://www.lowes.com/pd/Fiskars-Ultrasharp-7-5-in-Steel-Bypass-Lopper/1001459910> (Year: 2020).*

Fiskars UltraSharp 32-in Steel Bypass Lopper, Mar. 24, 2020 [online], [retrieved Nov. 20, 2023]. Retrieved from internet, <https://www.lowes.com/pd/Fiskars-Ultrasharp-8-in-Steel-Bypass-Lopper/1001459924> (Year: 2020).*

* cited by examiner

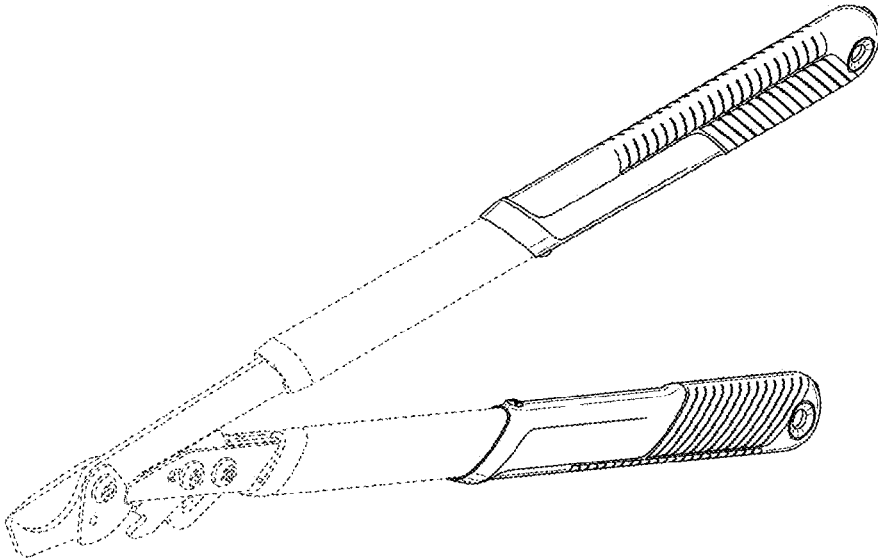

FIG. 1

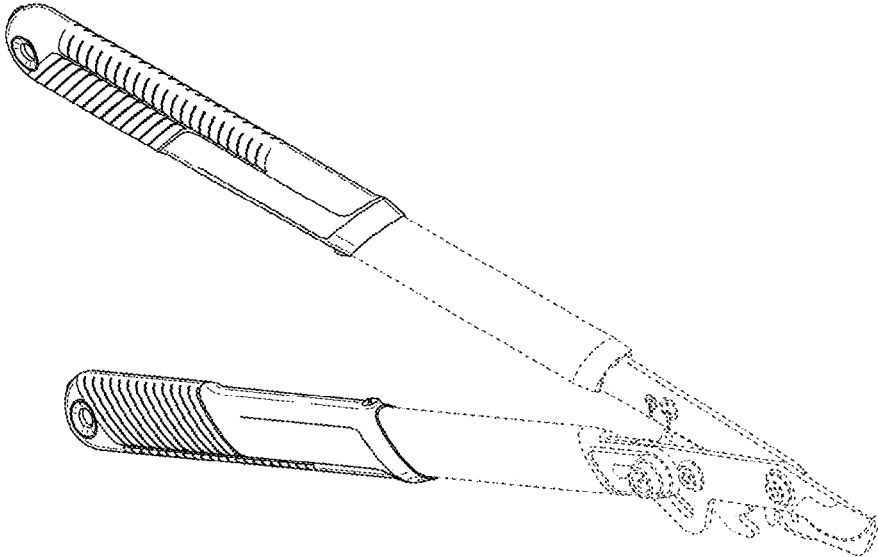

FIG. 2



FIG. 3

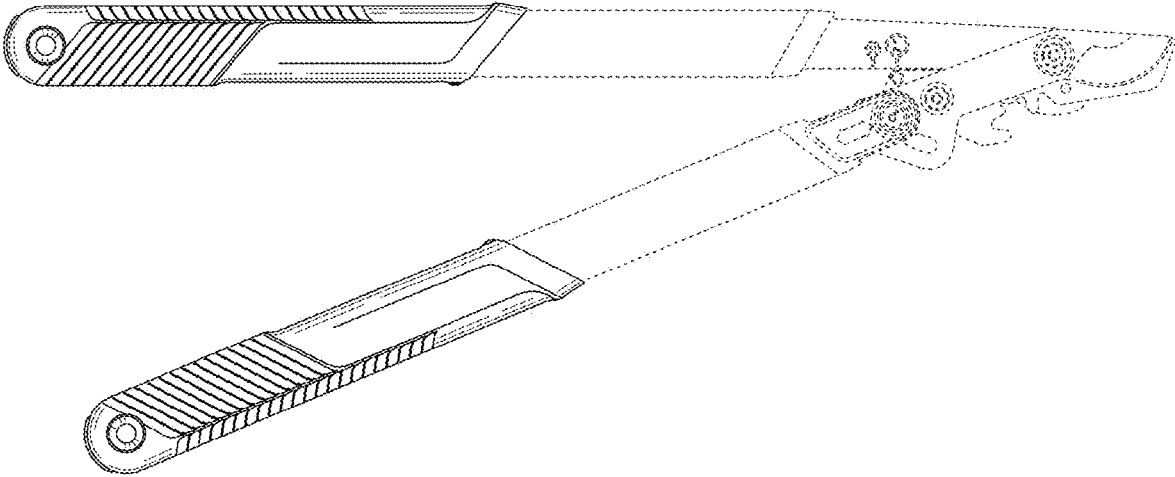

FIG. 4

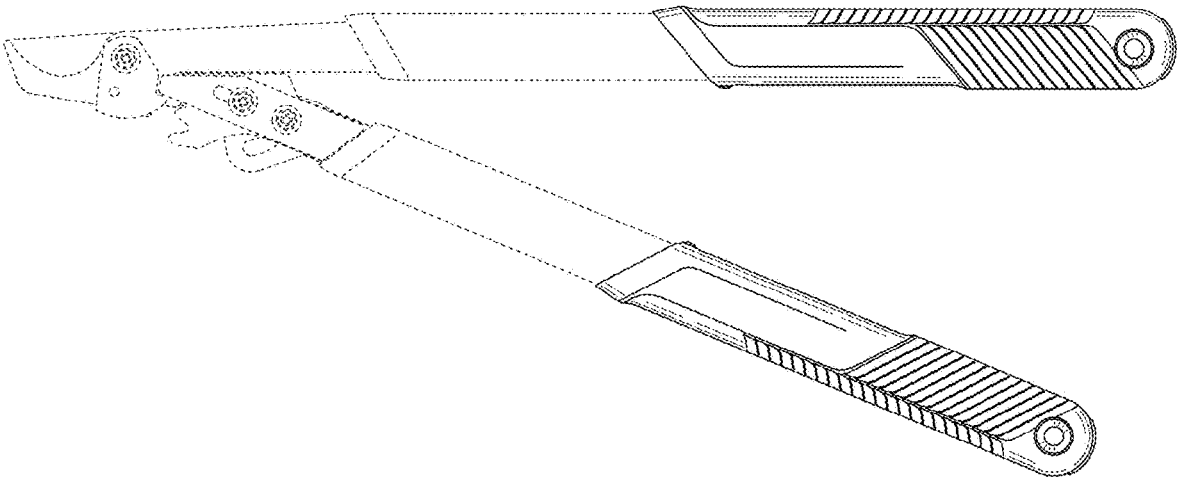

FIG. 5

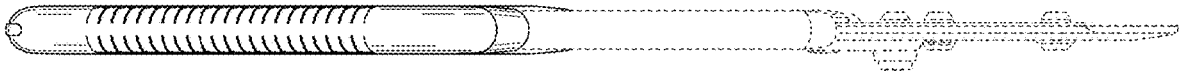

FIG. 6