

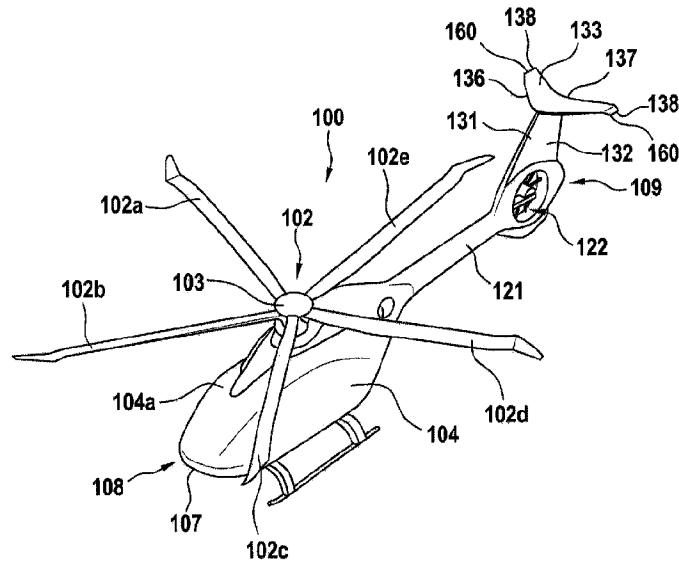

(22) Date de dépôt/Filing Date: 2020/01/31  
(41) Mise à la disp. pub./Open to Public Insp.: 2020/04/16  
(45) Date de délivrance/Issue Date: 2023/05/09  
(30) Priorité/Priority: 2019/04/26 (EP19400011.3)

(51) Cl.Int./Int.Cl. *B64C 5/02* (2006.01),  
*B64C 27/00* (2006.01)  
(72) Inventeurs/Inventors:  
EMBACHER, MARTIN, DE;  
RIES, TOBIAS, DE;  
ECKERT, CHRISTIAN, DE;  
KNEISCH, THOMAS, DE  
(73) Propriétaire/Owner:  
AIRBUS HELICOPTERS DEUTSCHLAND GMBH, DE  
(74) Agent: FASKEN MARTINEAU DUMOULIN LLP

(54) Titre : GIRAVION MUNI D'UNE AILE STABILISATRICE  
(54) Title: A ROTORCRAFT WITH A STABILIZER WING



(57) Abrégé/Abstract:

The present embodiments relate to a rotorcraft, and, more particularly, to a rotorcraft with a fuselage having a center line 230, at least one main rotor that generates vortices during operation, and a stabilizer wing 200, whereby the stabilizer wing 200 has a planform that reduces the unsteady aerodynamic loads caused by the wake of the at least one main rotor. In particular, the stabilizer wing 200 may be provided with a left wing tip 260, a right wing tip 260, a quarter chord line 240 with a non-zero curvature, such that an interaction between the vortices generated by the at least one main rotor and the quarter chord line 240 is spread out over time, a leading edge 210 that is arc-shaped, and a trailing edge 220 that is arc-shaped.

## ABSTRACT

The present embodiments relate to a rotorcraft, and, more particularly, to a rotorcraft with a fuselage having a center line 230, at least one main rotor that generates vortices during operation, and a stabilizer wing 200, whereby the stabilizer wing 200 has a planform that reduces the unsteady aerodynamic loads caused by the wake of the at least one main rotor. In particular, the stabilizer wing 200 may be provided with a left wing tip 260, a right wing tip 260, a quarter chord line 240 with a non-zero curvature, such that an interaction between the vortices generated by the at least one main rotor and the quarter chord line 240 is spread out over time, a leading edge 210 that is arc-shaped, and a trailing edge 220 that is arc-shaped.

## **A ROTORCRAFT WITH A STABILIZER WING**

### **Field**

The present embodiments relate to a rotorcraft, and, more particularly, to a rotorcraft with at least one main rotor and a stabilizer wing, whereby the stabilizer wing has a planform that reduces the unsteady aerodynamic loads caused on it by the wake of the at least one main rotor.

### **Background**

A rotorcraft is usually equipped with one or more wings that help to improve the stability and the handling of the rotorcraft during a flight. Therefore, such wings are sometimes also referred to as horizontal stabilizers, horizontal stabilizer wings, or stabilizer wings.

Conventionally, helicopters have one or more stabilizer wings placed at the rear end of a tail-unit. In some models, stabilizer wings protrude from a rear part of the tail boom or from the fin. In other models, a single stabilizer wing is placed on top of the fin. The latter configuration in which a single stabilizer wing is placed on top of the fin is sometimes also referred to as a T-tail.

Due to the location of the stabilizer wings at the aft region of the rotorcraft, they are typically subject to the air flow structures created by the at least one main rotor. These air flow structures, which are sometimes also referred to as wake or rotor wake, interact with the stabilizer wings and determine the aerodynamic load on the stabilizer wings.

The strength of the interaction between a rotor wake and a stabilizer wing depends on the positioning of the stabilizer wing relative to the rotor and on the flight state (e.g., during take-off and landing or during horizontal flight). However, the generation of aerodynamic loads on the stabilizer wing that are significant for the structural sizing of the stabilizer wing can usually not be avoided.

The stabilizer wing generates a certain amount of static aerodynamic load on purpose (e.g., to improve the stability and the handling of the rotorcraft during a flight). However, unwanted unsteady aerodynamic loads also result from the interaction of the rotor wake with the stabilizer wing.

These unsteady aerodynamic loads can sometimes reach significant amplitudes, which can lead to fatigue failures of the stabilizer wing. Therefore, special attention during the development of the stabilizer wing is often required to guarantee a structural design that significantly reduces the risk of fatigue failures caused by the unwanted unsteady aerodynamic loads.

The problem is often exacerbated by the fact that one of the dynamic natural frequencies of the stabilizer wing and the tail boom is close to the excitation frequency of the rotor wake. Such resonance conditions between the rotor wake and the stabilizer wing can be avoided by increasing either the structural stiffness or the mass of the stabilizer wing.

However, increasing the structural stiffness or the mass of the stabilizer wing adds weight in a sensitive area of the rotorcraft as it moves the center of gravity further to the rear. Especially when the stabilizer wing is placed on the fin, the structural and dynamical issues are difficult to solve. As a result, stabilizer wings are rarely placed on the fin, which would otherwise be very beneficial for handling quality and performance.

Instead, most conventional solutions place the stabilizer wing at a position that is in vertical direction below the rotor plane (e.g., at the tail boom). As a result, the interaction between the rotor wake and the stabilizer wing mostly occurs at lower flight speeds. Since air loads increase with flight speed, an interaction between the rotor wake and the stabilizer wing at lower flight speeds generates comparatively moderate unsteady aerodynamic loads, while the static air load on the stabilizer

wing is comparatively low. Thus, since the stabilizer wing's structure is subject to the superposition of the static air load and the unsteady aerodynamic loads, the stabilizer wing's structure does not reach its fatigue limits at lower flight speeds.

5           At high flight speeds, the rotor wake has changed its trajectory and passes above a low-positioned stabilizer wing (i.e., a stabilizer wing that is located at the tail boom, for instance). Thus, even though the static air load on the stabilizer wing is greater at high flight speeds than at low flight speeds, the comparatively small amplitude of unsteady aerodynamic  
10 loads of a low-positioned stabilizer wing has the effect that the total air load remains well within the envelope of the fatigue limits.

          However, a low-positioned stabilizer wing exhibits reduced handling qualities and performance compared to a high-positioned stabilizer wing (e.g., a stabilizer wing on top of the fin). For example, during hover and/or  
15 at low flight speed the low-positioned stabilizer wing lies within the rotor downwash and generates a force directed to the ground, which is sometimes also referred to as downforce. This downforce causes the rotorcraft to pitch up the nose region, which is sometimes also referred to as nose-up pitching.

20           A nose-up pitching can severely reduce the pilot's vision towards the ground. The nose-up pitching further generates a relatively high stress in the rotor mast. Moreover, the downforce can significantly reduce the payload of the rotorcraft. As an example, the downforce can reduce the payload of a helicopter in the three to four tons class by an amount that is  
25 equivalent to one passenger.

          Furthermore, a low-positioned stabilizer wing usually has to be mounted at the tail boom. This leads to a shorter lever arm and thereby to a reduced stabilizing effect compared to a high-positioned stabilizer wing.

30           Some helicopter manufacturers try to overcome the dilemma between handling and performance on one hand and flight stability on the other hand by adopting a high-positioned stabilizer wing. However, as

mentioned above, these high-positioned stabilizer wings face the problem of strong unsteady aerodynamic loads caused by the interaction with the rotor wake in cruise flight.

As the unsteady aerodynamic loads pose serious structural problems, a relatively small number of helicopters designed up to date features the high-positioned stabilizer wing. Often, helicopters with high-positioned stabilizer wings include additional means to reduce the unsteady aerodynamic loads. Among such means is the tapering of the stabilizer wings (i.e., the stabilizer wing has a chord length that is longer at the root than at the tips) or the inclusion of structural reinforcements. These reinforcements typically consist of thickening the stabilizer wing at its connection to the tail boom or fin, or installing struts that externally support the stabilizer wing.

For example, the AV-02 Hughes YAH-64 Advanced Attack Helicopter has a T-Tail (i.e., a stabilizer wing on the fin) with sweep (i.e., the stabilizer wing angles backwards from the root to the tips) and tapering. The Agusta-Bell BA609 features a T-Tail with tapering, whereby the stabilizer wing has straight leading and trailing edges. The RAH-66 Comanche has a T-Tail with a straight stabilizer wing (i.e., a stabilizer wing on top of the fin with straight leading and trailing edges but without a sweep). The Kamov Ka-60 has a T-Tail with a straight stabilizer wing and struts to the fin.

Both measures, the tapering of the stabilizer wing and the reinforcements, are disadvantageous from an aerodynamic point of view, as they increase drag, reduce the effectiveness of the stabilizer wing, and diminish the range of flight states in which the stabilizer wing has the capability to stabilize the rotorcraft.

The document EP 2 899 118 A1 describes a rotorcraft with a fuselage and at least one main rotor, said at least one main rotor being drivable for controlling an associated pitch attitude of said rotorcraft in operation, and said fuselage being equipped with at least one passive

wing-type aerodynamic device that is adapted for generating independently of said associated pitch attitude a lift force acting on said fuselage, said lift force being oriented perpendicular to an air flow that is directed in operation of said rotorcraft against said passive wing-type  
5 aerodynamic device. The rotorcraft further comprises a fin with a rudder and a tail wing in the form of a T-tail provided at the tail boom of the fuselage. The tail wing may be adjustable in its inclination and act as an additional lifting surface.

The document CN 103 979 105 A describes a vertical take-off and  
10 landing type variable-wing aircraft. The vertical take-off and landing type variable-wing aircraft comprises an aircraft body, a main wing, a left wing and a right wing, wherein the main wing is arranged at the lower part of the aircraft body; the left wing and the right wing are respectively connected to two ends of the main wing; a left wing rotation shaft sleeve  
15 and a right wing rotation shaft sleeve are mounted in the main wing; one set of left wing rotation shaft in the left wing rotation shaft sleeve is arranged in the left wing; one set of right wing rotation shaft in the right wing rotation shaft sleeve is arranged on the right wing; a left wing steering engine and a right wing steering engine are also arranged in the  
20 main wing; the left wing steering engine is used for driving the left wing rotation shaft to adjust the direction of the left wing; the right wing steering engine is used for driving the right wing rotation shaft to adjust the direction of the right wing. The vertical take-off and landing type variable-wing aircraft is capable of realizing the vertical take-off and  
25 landing of a model airplane and an unmanned aircraft, quickly realizing various flight states and effectively braking and moving backward in the flight.

The document EP 2 666 719 B1 describes an aircraft that includes a fuselage, at least one main rotor provided with a plurality of blades, at  
30 least a pusher propeller with variable pitch, at least one aerofoil and at least one motor rotationally driving the main rotor and each pusher

propeller. The aerofoil may comprise two half-wings positioned either side of the fuselage and at least one horizontal stabilizer positioned at one end of the aircraft and provided with at least one moving surface.

5 The document WO 1999/067130 A1 describes a horizontal stabilizer defining first and second spanwise stations wherein the first spanwise station defines a first angle of incidence and the second spanwise station defines a second angle of incidence and wherein the angle of incidence is different from one station to the other, e.g., one is greater than the other. The horizontal stabilizer functions to favorably affect the spanwise lift  
10 distribution to reduce the bending moments about its mounting interface. Various embodiments of the horizontal stabilizer include the use of vertically extending tabs along the trailing edge of the horizontal stabilizer, a stepped-transition to abruptly change the angle of incidence from one station to another, and a distributed twist which gradually  
15 changes the angle of incidence.

The document EP 0 254 605 A1 describes a directional and stabilizing device that comprises a ducted tail rotor driven in rotation in a transverse seam formed in a fairing inclined to the vertical by an angle between 0° and 45°. It also includes a tail "in-V" attached to the top of the  
20 shroud and the two aerodynamic surfaces extend asymmetrically relative to the vertical plane passing through the apex of the fairing. The aerodynamic surfaces and are inclined at angle ranges between 0° and 45°.

The document US 3,464,650 A describes an aircraft with a flapped  
25 rotor/wing for vertical and short take-off and landing (V/STOL) performance. On top of a vertical tail, the aircraft has a horizontal stabilizer, which may be of the all movable type, or have individually movable portions. These individual portions would act as conventional elevators, or could be connected to function as ailerons for roll control in  
30 forward flight in the manner of dual function elevation surfaces.

Conventional aircraft controls are used to operate the horizontal stabilizer, and the rudder on the vertical tail, for control in forward flight.

Other stabilizer wings are exemplarily described in documents CN 106 516 082 A, US 2016/0031554 A1, WO 2005/005250 A2, US 5,738,301 A, and US 3,902,688 A. These documents respectively describe stabilizer wings in a rotorcraft, which are at least similar to the above described stabilizer wings. The documents EP2409917 and WO2009155584 have been cited.

In summary, the interaction between rotor wake and horizontal stabilizer wings in rotorcrafts is dependent on the flight mode (i.e., hover, low-, or high-speed forward flight) and the placement of the stabilizer wing on the rotorcraft (i.e., low-positioned or high-positioned), which has an impact on the handling, the performance, and the flight stability. High-positioned stabilizer wings provide better handling, performance, and flight stability than low-positioned stabilizer wings. However, as mentioned above, high-positioned stabilizer wings face the problem of strong unsteady aerodynamic loads caused by the interaction with the rotor wake in cruise flight.

### **Summary**

It is, therefore, an objective to provide a rotorcraft with a fuselage, at least one main rotor, and a stabilizer wing. The stabilizer wing should reduce unsteady aerodynamic loads caused by the interaction with the rotor wake of the at least one main rotor while providing improved handling, performance, and flight stability compared to conventional stabilizer wings.

This objective is solved by a rotorcraft as per the present disclosure. More specifically, a rotorcraft may comprise a fuselage having a center line, at least one main rotor that generates vortices during operation, and a stabilizer wing that is connected to the fuselage. The stabilizer wing is provided with a left wing tip, a right wing tip, a quarter chord line with a non-zero curvature, such that an interaction between the vortices

generated by the at least one main rotor and the quarter chord line is spread out over time, a leading edge that is arc-shaped, and a trailing edge that is arc-shaped.

Advantageously, in the rotorcraft with the at least one main rotor, the above-described stabilizer wing with the quarter chord line having the non-zero curvature leads to reduced unsteady aerodynamic loads caused by the wake of the at least one main rotor on the stabilizer wing. Such stabilizer wings may be used on any rotorcraft with at least one main rotor including vertical take-off and landing aircraft, multicopters, helicopters, drones, etc.

The stabilizer wing has a particular planform (i.e., a particular shape when seen from above). The particular planform of the stabilizer wing reduces the unsteady loads generated by the interaction with the rotor wake of the at least one main rotor. In contrast to existing stabilizer wing planforms, which are mostly rectangular or consist of two trapezoids, a planform is proposed in which the leading and trailing edges feature a curvature.

Accordingly, the quarter chord line of the stabilizer wing is curved. In other words, the line that connects all points that are located at a quarter of the chord length, which is the distance from the leading to the trailing edge of the stabilizer wing along the chord, from the leading edge, is curved. Having a curved quarter chord line advantageously changes the response of the stabilizer wing to the fluctuations of the rotor wake compared to stabilizer wings with a straight quarter chord line.

In fact, a rotor wake exhibits a regular pattern of air flow at cruise flight, and this pattern determines the temporal sequence of load states at the stabilizer wing. A curved quarter chord line alters the relation between the stabilizer wing and the rotor wake flow pattern by reducing the amplitude of unsteady loads. Thereby, the stabilizer wing becomes less receptive to momentary load states of the type that generate high stress at the connection of the stabilizer wing with the rotorcraft (e.g., at the tail

boom or the fin), where the stabilizer wing is structurally sensitive. In particular the moment oscillations of the stabilizer wing around the longitudinal axis of the rotorcraft benefit from the reduced interaction between rotor wake and stabilizer wing because these moment oscillations are the most critical for the connection of the stabilizer wing with the rotorcraft from a structural point of view.

Since the proposed new planform of the stabilizer wing considerably reduces the unsteady loads of aerodynamic origin at the attachment location of the stabilizer wing, the attachment fitting of the stabilizer wing may be designed more weight-economically, and more space-economically (i.e., with less potentially negative impact on the aerodynamic shape of the interconnection region between stabilizer wing and tail boom or fin) than attachment fittings of conventional stabilizer wings.

Significant weight savings may be achieved thanks to the reduced unsteady aerodynamic loads. As an example, the stabilizer wing may require less structural reinforcements. As another example, the strength and the weight of the structures to which the stabilizer wing is attached (e.g., the tail boom or the fin) and to which the stabilizer wing transmits the unsteady aerodynamic loads may be structurally reduced as well.

The fin of a rotorcraft is often a structurally weak component. Therefore, a stabilizer wing with a curved quarter chord line that significantly decreases the unsteady loads caused by the rotor wake is especially beneficial when mounted to the fin. In fact, the aerodynamic interaction between the rotor wake and the stabilizer wing occurs at high speed and the unsteady loads at the stabilizer wing usually reach highest amplitudes when the stabilizer wing is mounted to the fin.

Moreover, the exposure time of the stabilizer wing to these high unsteady loads caused by the rotor wake amounts to a large fraction of the operation time of a rotorcraft. The large distance between the stabilizer wing and the fuselage renders the fin attachment into a joint,

which responds with large deflections to stabilizer wing loads and exhibits a low natural frequency that is difficult to correct if needed from a structural dynamics point of view.

5 A stabilizer wing with a curved quarter chord line may achieve the decisive amount of unsteady load reduction that is necessary to realize the otherwise challenging design of a fin-mounted stabilizer wing. Several important benefits for handling quality and performance can be realized If a stabilizer wing with a curved quarter chord line is mounted to the fin as detailed in the shortcomings of the prior art.

10 According to one aspect, the fuselage extends in longitudinal direction between a nose region and an aft region, and the quarter chord line of the stabilizer wing is closer to the aft region at at least one of the left or right wing tips than at the center line of the fuselage.

15 According to one aspect, the fuselage extends in longitudinal direction between a nose region and an aft region, and the quarter chord line of the stabilizer wing is closer to the nose region at at least one of the left or right wing tips than at the center line of the fuselage.

According to one aspect, an absolute value of the non-zero curvature of the quarter chord line is greater than 0.2.

20 According to one aspect, the absolute value of the non-zero curvature of the quarter chord line is smaller than 4.

25 According to one aspect, the non-zero curvature of the quarter chord line evolves from a first value at a first distance from the center line of the fuselage to a second value at a second distance from the center line of the fuselage such that the non-zero curvature of the quarter chord line is non-constant between the first and second distance from the center line of the fuselage.

30 According to one aspect, the stabilizer wing has a half wing span between the center line and a wing tip of the left or right wing tips, wherein first, second, third, and fourth points are located on the quarter chord line at first, second, third, and fourth distances from the center line

of the fuselage, respectively, wherein the first, second, third, and fourth distances amount to 10%, 30%, 50%, and 70% of the half wing span, respectively, wherein the non-zero curvature of the quarter chord line is non-zero between the first and fourth points, and wherein a straight line  
5 between the first and fourth points has a fifth distance from the quarter chord line between the second and third points that is greater than 2% of the half wing span.

According to one aspect, the quarter chord line is symmetrical to the center line of the fuselage.

10 According to one aspect, the stabilizer wing is mounted to at least one of the fuselage, a tail boom that is attached to the fuselage, or a vertical fin that is attached to the tail boom.

According to one aspect, the stabilizer wing has a constant chord length between the left and right wing tips of the stabilizer wing.

15 According to one aspect, the stabilizer wing has a chord length that decreases from the center line of the fuselage towards the left and right wing tips of the stabilizer wing.

20 According to one aspect, the stabilizer wing further comprises a left half wing having a first sweep, and a right half wing having a second sweep that is different than the first sweep.

According to one aspect, the left half wing has a quarter chord line with a first curvature, the right half wing has a quarter chord line with a second curvature, and the second curvature is different than the first curvature.

25 According to one aspect, the left half wing has a first length and the right half wing has a second length that is different than the first length.

According to one aspect, the stabilizer wing further comprises winglets.

30 According to one aspect, the rotorcraft may be embodied as a helicopter.

Hence, according to a broad aspect, there is provided a helicopter, comprising: a fuselage having a center line; a main rotor that generates vortices during operation; and a stabilizer wing connected to the fuselage, the stabilizer comprising (i) a left wing tip, (ii) a right wing tip, (iii) a quarter chord line, (iv) a leading edge that is arc-shaped, and (v) a trailing edge that is arc-shaped; wherein the quarter chord line has a non-zero curvature to reduce unsteady aerodynamic loads caused by a wake of the main rotor on the stabilizer wing compared to a stabilizer wing having a straight quarter chord line such that an interaction between vortices generated by the main rotor and the quarter chord line is spread out over time.

According to another broad aspect, there is provided a helicopter, comprising: a fuselage having a center line; a main rotor that generates vortices during operation; and a stabilizer wing connected to the fuselage, the stabilizer comprising (i) a left wing tip, (ii) a right wing tip, (iii) a quarter chord line, (iv) a leading edge that is arc-shaped, (v) a trailing edge that is arc-shaped, (vi) a left half wing having a first sweep and (vii) a right half wing having a second sweep that is different than the first sweep; wherein the quarter chord line has a non-zero curvature to reduce unsteady aerodynamic loads caused by a wake of the main rotor on the stabilizer wing compared to a stabilizer wing having a straight quarter chord line such that an interaction between vortices generated by the main rotor and the quarter chord line is spread out over time; wherein the left half wing has a quarter chord line with a first curvature; wherein the right half wing has a quarter chord line with a second curvature; and wherein the second curvature is different than the first curvature.

According to a further broad aspect, there is provided a helicopter, comprising: a fuselage having a center line; a main rotor that generates vortices during operation; and a stabilizer wing connected to the fuselage, the stabilizer comprising (i) a left wing tip, (ii) a right wing tip, (iii) a quarter chord line, (iv) a leading edge that is arc-shaped, (v) a trailing

edge that is arc-shaped, (vi) a left half wing having a first sweep and (vii) a right half wing having a second sweep that is different than the first sweep; wherein the quarter chord line has a non-zero curvature to reduce unsteady aerodynamic loads caused by a wake of the main rotor on the stabilizer wing compared to a stabilizer wing having a straight quarter chord line such that an interaction between vortices generated by the main rotor and the quarter chord line is spread out over time; and wherein the left half wing has a first length and the right half wing has a second length that is different than the first length.

According to another broad aspect, there is provided a helicopter, comprising: a fuselage having a center line; a main rotor that generates vortices during operation; and a stabilizer wing connected to the fuselage, the stabilizer comprising (i) a left wing tip, (ii) a right wing tip, (iii) a quarter chord line having a curvature, (iv) a leading edge that is arc-shaped, and (v) a trailing edge that is arc-shaped; wherein the quarter chord line is a function and the curvature is a second derivative of the function; and wherein, an absolute value of the curvature of the quarter chord line is between -0.9 and -0.1 or between 0.1 and 4 for reducing unsteady aerodynamic loads generated by a wake of the main rotor and for spreading out over time vortices generated by the main rotor on the stabilizer wing.

#### **Brief description of the drawings**

Embodiments are outlined by way of example in the following description with reference to the attached drawings. In these attached drawings, identical or identically functioning components and elements may be labeled with identical reference numbers and characters and are, consequently, only described once in the following description.

- Figure 1A is a diagram of an illustrative rotorcraft with a stabilizer wing in accordance with some embodiments,

- Figure 1B is a simplified side view of an illustrative rotorcraft in accordance with some embodiments,

- Figure 1C is a simplified top view of an illustrative rotorcraft in accordance with some embodiments,

5 - Figure 2 is a diagram of an illustrative stabilizer wing having a quarter chord line with a non-zero curvature in accordance with some embodiments,

- Figure 3A is a diagram of an illustrative interaction between a rotor tip vortex center line reaching a quarter chord line with a non-zero curvature of a left half of a stabilizer wing in accordance with some embodiments,

10 - Figure 3B is a diagram of an illustrative interaction between a rotor tip vortex center line passing over a quarter chord line with a non-zero curvature of a left half of a stabilizer wing in accordance with some embodiments,

15 - Figure 3C is a diagram of an illustrative interaction between a rotor tip vortex center line reaching the intersection of a quarter chord line with a non-zero curvature of a stabilizer wing and the center line of a fuselage in accordance with some embodiments,

20 - Figure 4 is a diagram of a series of rotor tip vortex center lines reaching an illustrative stabilizer wing having a constant chord length and a quarter chord line with a non-zero curvature in accordance with some embodiments,

25 - Figure 5 is a diagram of a series of rotor tip vortex center lines reaching an illustrative stabilizer wing having an asymmetric sweep between the left and right half wings in accordance with some embodiments, and

- Figure 6 is a diagram of an illustrative stabilizer wing having a tapered chord length, a quarter chord line with a non-zero curvature, and a wing center line that is perpendicular to a series of rotor tip vortex center lines in accordance with some embodiments.

30 Figures 1A, 1B, and 1C show a rotorcraft 100 with a fuselage 104 and a main rotor 102. Figure 1A shows a three-dimensional representation

of rotorcraft 100, while Figure 1B illustrates a simplified side view of rotorcraft 100 and Figure 1C a simplified top view of rotorcraft 100.

### **Detailed description of embodiments**

5 Variants, examples, and preferred embodiments of the invention are described hereinbelow. The rotorcraft 100 is illustratively embodied as a helicopter and the main rotor 102 is illustratively embodied as a hingeless or a hinge- and bearingless multi-blade rotor having a plurality of rotor blades 102a, 102b, 102c, 102d, 102e.

10 It should, however, be noted that the present embodiments are not limited to helicopters and may likewise be applied to other rotorcrafts that are equipped with rotary wings, independent on whether these rotary wings define articulated, hingeless or hinge- and bearingless multi-blade rotors. It should further be noted that the present embodiments may also be applied in cases where more than one main rotor is provided.

15 In fact, exemplary embodiments may be included in any rotorcraft with at least one main rotor and a stabilizer wing, in which the unsteady aerodynamic loads caused by the wake of the at least

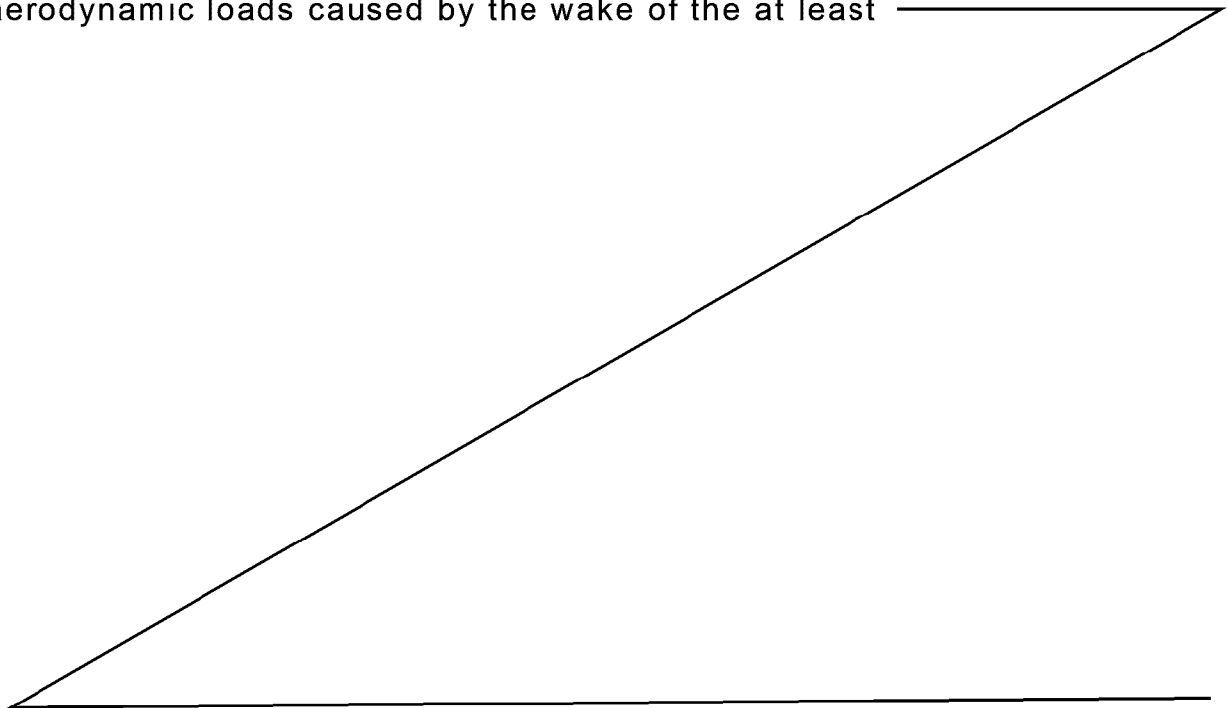

one main rotor on the stabilizer wing should be reduced. Examples of such vehicles may include rotorcrafts such as vertical take-off and landing aircraft, multicopters, helicopters, drones, etc.

5 Illustratively, rotorcraft 100 may have a fuselage 104 that forms an airframe of rotorcraft 100. Fuselage 104 may be connected to a suitable landing gear and a rear fuselage. As an example, the landing gear may be a skid-type landing gear as shown in Figure 1A. As another example, the landing gear may have wheels as shown in Figure 1B. The rear fuselage may be connected to a tail boom 121.  
10 Fuselage 104 exemplarily forms a cabin 104a defining a fuselage nose 107 at a nose region 108 of rotorcraft 100.

Figures 1B and 1C show rotorcraft 100 in a cartesian coordinate system with axes X, Y, and Z. The X axis extends in longitudinal direction of rotorcraft 100 through nose region 108 and aft region 109  
15 and is sometimes also referred to as longitudinal axis or length axis.

The Y axis extends in transversal direction of rotorcraft 100 through left and right wing tips 160 of stabilizer wing 133 and is sometimes also referred to as transversal axis, lateral axis, or width axis. The Z axis extends in vertical direction of rotorcraft 100 and is  
20 sometimes also referred to as vertical axis or height axis.

Fuselage 104 may have center line 130. Center line 130 may be parallel to or coincide with the X axis through main rotor center 103. In other words, the plane defined by the center line 130 and the Z axis may define a symmetry axis of fuselage 104 in transversal  
25 direction.

By way of example, rotorcraft 100 may include at least one counter-torque device configured to provide counter-torque during

operation, i.e. to counter the torque created by rotation of the at least one multi-blade rotor 102 for purposes of balancing the rotorcraft 100 in terms of yaw. If desired, the counter-torque device may be shrouded. The at least one counter-torque device is illustratively provided at an aft region 109 of rotorcraft 100 and may have a tail rotor 122.

Aft region 109 of rotorcraft 100 may include fin 131 that is attached to tail boom 121, if desired. In some embodiments, fin 131 may be provided with a rudder 132. Rudder 132 may be adapted to provide for enhanced directional control and for optimized yaw trim of rotorcraft 100. If desired, rudder 132 can be deflected to large angles to reduce a given lateral drag of fin 131 in sideward flight.

Illustratively, fin 131 may be provided with a suitable horizontal stabilizer wing 133 in the form of a T-tail. In other words, as shown in Figures 1A and 1B, horizontal stabilizer wing 133 may be connected to fuselage 104 via fin 131 and tail boom 121. As shown, stabilizer wing 133 may be mounted to the top of fin 131.

If desired, stabilizer wing 133 may be mounted at another position of rotorcraft 100. For example, stabilizer wing 133 may be mounted directly to fuselage 104, to tail boom 121, and/or to fin 131 at a position that is in height axis Z below the top of fin 131.

Stabilizer wing 133 may be provided with left and right wing tips 160, a leading edge 136 that is arc-shaped, and a trailing edge 137 that is arc-shaped.

By way of example, stabilizer wing 133 may have a constant chord length. In other words, the chord of stabilizer wing 133, which is the imaginary straight line that joins leading edge 136 and trailing

edge 137 of stabilizer wing 133, may have a constant length for every point on leading edge 136. If desired, stabilizer wing 133 may have a tapered chord length. In other words, the chord length of stabilizer wing 133 may be greater at the center line 130 of fuselage 104 than  
5 at left and right wing tips 160.

Illustratively, the quarter chord line of stabilizer wing 133, which is the imaginary line that connects all points on the different chords that are at a quarter of the respective chord length from the leading edge 136, may have a non-zero curvature.

10 As shown in Figures 1A and 1C, the quarter chord line of stabilizer wing 133 is curved backwards. In other words, when drawing a connection line between two arbitrary points on the quarter chord line of stabilizer wing 133, the quarter chord line segment in between these two arbitrary points is closer to the nose region 108  
15 than the connection line.

If desired, the quarter chord line of stabilizer wing 133 may be curved forward. In other words, when drawing a connection line between two arbitrary points on the quarter chord line of stabilizer wing 133, the quarter chord line segment in between these two  
20 arbitrary points is closer to the aft region 109 than the connection line.

If desired, stabilizer wing 133 may have vertical or near-vertical extensions at the left and right wing tips 160. Such vertical or near-vertical extensions at the wing tips are sometimes also referred to as  
25 winglets 138. As shown in Figure 1A, stabilizer wing 133 has downward-angled winglets 138. However, stabilizer wing 133 may have upward-angled winglets 138 or winglets 138 that extend upwards and downwards, if desired.

The main rotor 102 and, thus, the plurality of rotor blades 102a, 102b, 102c, 102d, 102e is drivable, i.e. controllable to influence an associated pitch attitude of the rotorcraft 100 in operation. Illustratively, the main rotor 102 defines a main rotor center 103 and  
5 comprises a rotor mast. The rotor mast has a rotor mast axis (e.g., rotor mast axis 103a of Figure 1B) that defines a rotational axis of the main rotor 102.

During operation, main rotor 102 may generate air flow structures for providing lift and forward or backward thrust. Such air  
10 flow structures are sometimes also referred to as rotor wake or wake. The rotor wake of main rotor 102 may interact with stabilizer wing 133. In particular, the rotor wake may put an aerodynamic load on stabilizer wing 133.

The aerodynamic load on stabilizer wing 133 may be divided  
15 into a static aerodynamic load and an unsteady aerodynamic load. The static aerodynamic load is desirable because it improves flight stability and performance. The unsteady aerodynamic load is unwanted because it creates structural stress at the stabilizer wing 133 and the portions of rotorcraft 100 to which stabilizer  
20 wing 133 is attached.

The unsteady aerodynamic loads on stabilizer wing 133 are caused by changes in the air flow speed and/or the air flow direction and may cause lift changes at stabilizer wing 133. These lift changes on the stabilizer wing 133 occur as a response to flow changes at the  
25 quarter chord line of stabilizer wing 133.

Important changes in air flow speed and direction occur in the rotor wake in form of vortices. Vortices are volumes of air that revolve around an elongated, usually curved axis which is the center of the

vortex. In rotorcraft 100, vortices are emanating from the tips of rotor blades 102a, 102b, 102c, 102d, 102e.

5 Due to the rotor blades' rotation and simultaneous forward motion in the direction of flight, the shape of the axis of a rotor tip vortex resembles that of a helix when seen from above. The helix, while created at the rotor blades' tips, is moving backwards relative to rotorcraft 100 during forward flight at a speed nearly identical to flight speed. A certain portion of the rotor blade tip vortices will travel by the stabilizer wing 133 and cause the unsteady aerodynamic loads.

10 Since lift changes on the stabilizer wing 133 occur as a response to flow changes at the quarter chord line of stabilizer wing 133, unsteady aerodynamic loads on the stabilizer wing 133 can be modeled approximately by the interaction between the rotor blade tip vortices and the quarter chord line of stabilizer wing 133.

15 As mentioned above, the quarter chord line of stabilizer wing 133 has a non-zero curvature. Thus, the interaction between the vortices generated by the at least one main rotor 102 and the quarter chord line may be spread out over time compared to stabilizer wings with a straight quarter chord line.

20 In fact, due to the helix pattern, rotor blade tip vortices periodically pass by the quarter chord line of stabilizer wing 133. For a rotor with  $N$  rotor blades,  $N$  helix-shaped rotor tip vortex systems are created, and hence  $N$  rotor blade tip vortices pass by stabilizer wing 133 per rotor revolution. Accordingly, the unsteady aerodynamic  
25 loads at stabilizer wing 133 occur periodically with fundamental frequency  $N$  per rotor revolution.

Thanks to the curved shape of the quarter chord line, the shape of the periodic unsteady aerodynamic loads at the attachment of stabilizer wing 133 at fin 131 or tail boom 121 may have smoother peaks and reduced amplitudes compared to a stabilizer wing with a straight quarter chord line. This is further illustrated in Figures 3A to 3C.

Figure 2 shows an illustrative stabilizer wing having a quarter chord line with a non-zero curvature in accordance with some embodiments. As shown in Figure 2, stabilizer wing 200 may have an arc-shaped leading edge 210, an arc-shaped trailing edge 220, and a quarter chord line 240 with a non-zero curvature.

The term “arc-shaped” as applied to leading edge 210 implies that leading edge 210 is curved at least partially between the wing tips 260. Preferably, leading edge 210 is curved at least in the vicinity of center line 230. If desired, arc-shaped leading edge 210 may be partially straight.

Similarly, the term “arc-shaped” as applied to trailing edge 220 implies that trailing edge 220 is curved at least partially between the wing tips 260. Preferably, trailing edge 220 is curved. If desired, arc-shaped trailing edge 220 may be partially straight.

Only by way of example and not to restrict the present embodiments accordingly, arc-shaped objects include at least partly C-shaped objects, objects shaped like a parabola segment, objects shaped like a segment of an ellipse, semi-oval objects, objects that are round in some portions and straight at other portions, etc.

As shown in Figure 2, stabilizer wing 200 may have wing span 255 which may be the distance between the left and right wing

tips 260. Wing span 255 may be the sum of a left half wing span 257 and a right half wing span 258, whereby the left half wing span 257 may be the distance between the left wing tip 260 and center line 230, and the right half wing span 258 may be the distance  
5 between the right wing tip 260 and the center line 230.

Illustratively, stabilizer wing 200 may have a chord length 250 that decreases from the center line 230 of the fuselage towards the left and right wing tips 260. In other words, stabilizer wing 200 may be tapered. If desired, stabilizer wing 200 may have a constant chord  
10 length for at least a portion of wing span 255.

Consider the scenario in which a coordinate system is introduced as shown in Figure 2 with the Y axis as the lateral or transversal axis and the X axis as the length or longitudinal axis. Consider further that the Y axis is scaled such that the left and right  
15 wing tips 260 coincide with the coordinates  $Y = -1$  and  $Y = 1$ , respectively, and that the origin is on the center line 230. Consider further that the X axis shall be scaled such that the distance from the origin to  $X = 1$  is equal to the span of a half-wing.

If desired, in case of a stabilizer wing 200 with non-equal spans  
20 of the left and right half wings, an individual coordinate system for each half-wing may be introduced. However, as shown in Figure 2, stabilizer wing 200 has equal spans of the left and right half wings 257, 258 and a quarter chord line 240 that is symmetrical to center line 230 of the fuselage.

25 In this scenario, quarter chord line 240 may be described as a function  $X = f(Y)$ , whereby the curvature of the quarter chord line 240 is the second derivative  $d^2/dY^2 (f(Y))$ . As the X axis is positive towards leading edge 210, a backward curvature (i.e., the opening of

the curvature is oriented towards the aft region of the rotorcraft (e.g., aft region 109 of rotorcraft 100 of Figure 1)) corresponds to negative values (i.e.,  $d^2/dY^2 (f(Y)) < 0$ ), and a forward curvature (i.e., the opening of the curvature is oriented towards the nose region of the rotorcraft (e.g., nose region 108 of rotorcraft 100 of Figure 1)) to positive values (i.e.,  $d^2/dY^2 (f(Y)) > 0$ ), while a straight quarter chord line has a zero curvature (i.e.,  $d^2/dY^2 (f(Y)) = 0$ ).

As an example, the absolute value of the non-zero curvature of the quarter chord line 240 may be greater than 0.2 (i.e.,  $|d^2/dY^2 (f(Y))| > 0.2$ ). As another example, the absolute value of the non-zero curvature of the quarter chord line 240 may be smaller than 4 (i.e.,  $|d^2/dY^2 (f(Y))| < 4$ ).

If desired, the absolute value of the non-zero curvature of the quarter chord line 240 may have an upper limit based on the distance from center line 230. For example, the absolute value of the non-zero curvature of the quarter chord line 240 may be smaller than  $4 - 2*|Y|$  (i.e.,  $|d^2/dY^2 (f(Y))| < 4 - 2*|Y|$ ).

Illustratively, quarter chord line 240 may have a non-zero curvature (i.e.,  $d^2/dY^2 (f(Y)) \neq 0$ ) over the entire wing span 255. If desired, quarter chord line 240 may have a non-zero curvature (i.e.,  $d^2/dY^2 (f(Y)) \neq 0$ ) in the ranges  $Y = ] 0.1; 0.9]$  and  $Y = ]-0.1; -0.9]$  or parts of these ranges. As an example, quarter chord line 240 may have a non-zero curvature at least in the ranges  $Y = ] 0.1; 0.7]$  and/or  $Y = ]-0.1; -0.7]$ .

In other words, considering only the right half wing (i.e.,  $Y = ] 0.1; 0.7]$ ), two points 272, 278 may be located on quarter chord line 240 at distances 282, 288 from center line 230 of the fuselage, respectively, such that the distances 282, 288 amount to 10% and

70% of the half wing span 257, 258, respectively, whereby the non-zero curvature of the quarter chord line 240 is non-zero at least between the two points 272, 278.

If desired, two additional points 274, 276 may be located on  
5 quarter chord line 240 at distances 284, 286 from center line 230 of the fuselage, respectively, such that the distances 284, 286 amount to 30% and 50% of the half wing span 257, 258, and a straight line 290 between the two points 272, 278 may have distance 270 from quarter chord line 240 between the two additional points 274, 276 that  
10 is greater than 2% of the half wing span 257, 258.

In some embodiments, the non-zero curvature of the quarter chord line 240 evolves from a first value at a first distance from the center line 230 of the fuselage to a second value at a second distance from the center line 230 of the fuselage such that the non-  
15 zero curvature of the quarter chord line 240 is non-constant between the first and second distance from the center line 230 of the fuselage.

As an example, quarter chord line 240 may have a curvature of 2.5 at center line 230 (i.e.,  $|d^2/dY^2 (f(Y))| = 2.5$  at  $Y = 0$ ) and decrease towards the left and right wing tips 260 to a curvature of 0.5 (i.e.,  
20  $|d^2/dY^2 (f(Y))| = 0.5$  at  $Y = \pm 1$ ). As another example, quarter chord line 240 may have a curvature of 3.0 at center line 230 (i.e.,  $|d^2/dY^2 (f(Y))| = 3.0$  at  $Y = 0$ ) and decrease towards the left and right wing tips 260 to a curvature of 0.25 (i.e.,  $|d^2/dY^2 (f(Y))| = 0.25$  at  $Y = \pm 1$ ).

In some embodiments, quarter chord line 240 may have a kink.  
25 As an example, the kink in quarter chord line 240 may be at center line 230 (i.e., at  $Y = 0$ ). As another example, quarter chord line 240 may have a kink towards the left and right wing tips 260 (e.g., at  $Y = \pm 0.95$ ).

If desired, a family of embodiments may be conceived by an amount of mean curvature over a particular Y range. Thereby, the mean curvature over a range of Y values (i.e., in the interval [Y1; Y2]), is defined as the absolute value of the difference between the first derivative at the start of the range (i.e.,  $d/dY(f(Y); Y = Y1)$ ) and the first derivative at the end of the range (i.e.,  $d/dY(f(Y); Y = Y2)$ ) divided by (Y2-Y1). The amount of mean curvature is hence  $| (d/dy(f(Y); Y = Y1) - d/dY(f(Y); Y = Y2))/(Y2-Y1) |$ .

Examples for such families of embodiments are shown in Tables 1, 2, and 3. Table 1 shows the families of embodiments for Y1 = 0.1, Table 2 the families of embodiments for Y1 = 0.2, and Table 3 the families of embodiments for Y1 = 0.3. Additional families of embodiments are possible for different values of Y1 and/or Y2.

Table 1

	Y1  = 0.1,  Y2  = 0.9	Y1  = 0.1,  Y2  = 0.8	Y1  = 0.1,  Y2  = 0.7	Y1  = 0.1,  Y2  = 0.5
Amount of mean curvature $\epsilon ]0.2;0.5]$	Family 1a	Family 1b	Family 1c	Family 1d
Amount of mean curvature $\epsilon ]0.5;1.0]$	Family 2a	Family 2b	Family 2c	Family 2d
Amount of mean curvature $\epsilon ]1.0;2.0]$	Family 3a	Family 3b	Family 3c	Family 3d
Amount of mean curvature $\epsilon ]2.0;4.0]$	Family 4a	Family 4b	Family 4c	Family 4d

Table 2

	$ y_1  = 0.2,$ $ y_2  = 0.9$	$ y_1  = 0.2,$ $ y_2  = 0.8$	$ y_1  = 0.2,$ $ y_2  = 0.7$	$ y_1  = 0.2,$ $ y_2  = 0.5$
Amount of mean curvature $\epsilon$ ]0.2;0.5]	Family 1e	Family 1f	Family 1g	Family 1h
Amount of mean curvature $\epsilon$ ]0.5;1.0]	Family 2e	Family 2f	Family 2g	Family 2h
Amount of mean curvature $\epsilon$ ]1.0;2.0]	Family 3e	Family 3f	Family 3g	Family 3h
Amount of mean curvature $\epsilon$ ]2.0;4.0]	Family 4e	Family 4f	Family 4g	Family 4h

Table 3

	$ y_1  = 0.3,$ $ y_2  = 0.9$	$ y_1  = 0.3,$ $ y_2  = 0.8$	$ y_1  = 0.3,$ $ y_2  = 0.7$	$ y_1  = 0.3,$ $ y_2  = 0.5$
Amount of mean curvature $\epsilon$ ]0.2;0.5]	Family 1i	Family 1k	Family 1l	Family 1m
Amount of mean curvature $\epsilon$ ]0.5;1.0]	Family 2i	Family 2k	Family 2l	Family 2m
Amount of mean curvature $\epsilon$ ]1.0;2.0]	Family 3i	Family 3k	Family 3l	Family 3m
Amount of mean curvature $\epsilon$ ]2.0;4.0]	Family 4i	Family 4k	Family 4l	Family 4m

The variability of coordinate  $Y_1$  may be important for stabilizer wings 200 that protrude from a fuselage, a fin, or a tail boom (e.g., fuselage 104, fin 131, or tail boom 121 of rotorcraft 100 of Figure 1). For example, a stabilizer wing that protrudes from a tail boom may not have curvature values at  $Y$  values that would be inside the tail boom. Consequently, an embodiment may be chosen from a family that features a value for  $Y_1$  that lies outside of the tail boom.

As mentioned above, a rotor with  $N$  rotor blades creates  $N$  helix-shaped rotor tip vortex systems, and hence  $N$  rotor blade tip vortices

pass by stabilizer wing 200 per rotor revolution. Accordingly, the unsteady aerodynamic loads at stabilizer wing 200 occur periodically with fundamental frequency  $N$  per rotor revolution.

Thanks to the curved shape of the quarter chord line, the shape of the periodic unsteady aerodynamic loads at the attachment of stabilizer wing 200 at a fin or a tail boom may have smoother peaks and reduced amplitudes compared to a stabilizer wing with a straight quarter chord line.

Figures 3A, 3B, and 3C are diagrams of an illustrative temporal sequence of interactions between a rotor tip vortex center line and a quarter chord line with a non-zero curvature. As shown in Figures 3A, 3B, and 3C, stabilizer wing 300 may have an arc-shaped leading edge 310, an arc-shaped trailing edge 320, and quarter chord line 340. Illustratively shown is center line 330 of the fuselage to which stabilizer wing 300 is symmetrical. Hence, quarter chord line 340 is symmetrical to center line 330.

Considering that the rotorcraft stands on its landing gear, a rotor may turn counter clockwise when looked upon from above or may turn clockwise when looked upon from above.

Figure 3A shows rotor tip vortex center line 360 reaching quarter chord line 340. In this initial situation (i.e.,  $T = T_1$ ) the rotor tip vortex center line 360 is tangent to quarter chord line 340 and the interaction between rotor tip vortex center line 360 and quarter chord line 340 starts.

Figure 3B shows rotor tip vortex center line 370 passing over quarter chord line 340 a short time after the interaction has started (i.e., at  $T = T_2$  with  $T_2 > T_1$ ).

Figure 3C shows rotor tip vortex center line 380 when the interaction with quarter chord line 340 ends and the rotor tip vortex center line 380 reaches the intersection of quarter chord line 340 and center line 330 (i.e., at  $T = T3$  with  $T3 > T2$ ).

5           The rotor tip vortex center line 360, 370, 380 travels for a longer time (i.e.,  $T1$  to  $T3$ ) and a longer distance over curved quarter chord line 340 of stabilizer wing 300 than over a comparable straight quarter chord line of a comparable stabilizer wing.

10           Thus, rotor tip vortex center line 360, 370, 380 interacts for a longer duration with the curved quarter chord line 340 than it would interact with a straight quarter chord line. The longer duration of the interaction between rotor tip vortex center line 360, 370, 380 and quarter chord line 340 implies, at one particular time instant, a comparatively locally more restricted impact on the quarter chord  
15           line 340, and thus a smaller aerodynamic load input on stabilizer wing 300.

          In contrast, if the duration of the interaction is short, or if in the extreme case the rotor tip vortex center line 360 and the quarter chord line are nearly coincident for just a time instant (e.g., as it can  
20           occur more likely in the case of a straight quarter chord line than in the case of a properly curved quarter chord line), the aerodynamic load change is instantaneous as it occurs along the entire span of the stabilizer wing at nearly the same time instant, thereby causing short and intense aerodynamic load peaks.

25           The present embodiments of a stabilizer wing 300 with a curved quarter chord line 340 allow for a long interaction time (e.g.,  $T1$  to  $T3$ ) between a rotor tip vortex center line 360, 370, 380 and stabilizer wing 300 by creating a large difference in curvature and orientation of

the quarter chord line 340 from the curvature and orientation of the rotor tip vortex center lines 360, 370, 380.

Figures 3A, 3B, and 3C show the interaction between forward curved rotor tip vortex center line 360, 370, 380 at times T1, T2, and T3, respectively, and backward curved quarter chord line 340. Rotor tip vortex center lines with a forward curvature, as shown in Figures 3A, 3B, and 3C, are usually more relevant for a T-tail (i.e., a stabilizer wing that is attached on top of a fin) in cruise flight, because forward-curved rotor tip vortex center lines are generated at the rear edge of the rotor disk and a T-tail stabilizer wing is geometrically close to the rear rotor edge.

Therefore, a T-tail stabilizer wing with a backward curved quarter chord line may be less affected by the rotor tip vortex center lines generated at the rear edge of the rotor disk than a stabilizer wing with a straight quarter chord line.

However, a rotor also generates rotor tip vortex center lines with backward curvature. For example, a rotor may generate rotor tip vortex center lines with a backward curvature at the front edge of the rotor disk.

A stabilizer wing that is attached such that it interacts in many flight conditions with vortices generated at the front edge of the rotor disk may interact for a longer time with these backward curved rotor tip vortex center lines if the stabilizer wing's quarter chord line has a forward curvature. Therefore, a stabilizer wing with forward curvature may experience lower aerodynamic load peaks when exposed to rotor tip vortex center lines with backward curvature.

Consider the scenario in which the rotorcraft is a helicopter with one main rotor. Consider further that the main rotor center of the main rotor coincides with the center line of the fuselage (e.g., main rotor center 103 coincides with center line 130 of fuselage 104 of Figure 1C) and that, due to the asymmetrical nature of the main rotor with respect to the mid-plane of the helicopter, the rotor tip vortex center lines shed by the main rotor are not symmetric to the center line of the fuselage.

In this scenario, the curvature shape of the quarter chord line 340 and thus the planform of stabilizer wing 300 may be tailored towards the minimization of aerodynamic loads. As an example, the planform of stabilizer wing 300 may be designed such that, based on the operation of the rotorcraft, the total aerodynamic loads (e.g., obtained by integration over the wing span of stabilizer wing 300) at a predetermined location (e.g., the attachment position of stabilizer wing 300) do not exceed a predetermined value.

As another example, the planform of stabilizer wing 300 may be designed such that, based on the operation of the rotorcraft, the temporal sequence of the local interactions between the rotor tip vortex center lines 360, 370, 380 and the quarter chord line 340 at each location of stabilizer wing 300 is suitably staggered to achieve a near constant total aerodynamic load at the relevant location of stabilizer wing 300 in time.

As shown in Figures 2, 3A, 3B, and 3C, the stabilizer wing may be tapered. In other words, the chord length 250 may be longer at center line 230 than at wing tips 260, or the ratio of chord length 250 at wing tips 260 divided by chord length 250 at center line 230 may be smaller than one. As an example, the ratio of chord length 250 at

wing tips 260 divided by chord length 250 at center line 230 may be in the interval between 0.2 and 0.8.

However, even though the stabilizer wing 200, 300 shown in Figures 2, 3A, 3B, and 3C is tapered, a curved quarter chord line 240, 340 may be combined with any kind of spanwise chord length evolution.

As an example, Figure 4 is a diagram of a series of rotor tip vortex center lines 460, 470, 480 reaching an illustrative stabilizer wing 400 with a constant chord length 450 in accordance with some embodiments. In other words, stabilizer wing 400 may have a constant chord length 450 between the left and right wing tips 457 of the stabilizer wing 400.

As shown in Figure 4, stabilizer wing 400 may have an arc-shaped leading edge 410, an arc-shaped trailing edge 420, and a quarter chord line 440 with a non-zero curvature. Illustratively shown is center line 430 of the fuselage to which stabilizer wing 400 is symmetrical. Hence, quarter chord line 440 is symmetrical to center line 430.

By way of example, chord length 450 may be constant at any span station  $Y$  (i.e., everywhere between  $Y = -1$  and  $Y = 1$ ). In this example, since stabilizer wing 400 has an arc-shaped leading edge 410 and a constant chord length 450 at any span station  $Y$ , leading edge 410, trailing edge 420 and quarter chord line 440 have the same arc shape and the same non-zero curvature.

As shown in Figures 2, 3A, 3B, 3C, and 4, the stabilizer wing 200, 300, 400 may be symmetrical to the center line 230, 330,

430. However, the stabilizer wing may be asymmetrical to the center line, if desired.

As an example, Figure 5 is a diagram of a series of rotor tip vortex center lines 560, 570, 580 reaching an illustrative stabilizer wing 500 having an asymmetric sweep between the left and right half wings 504, 502 in accordance with some embodiments.

In fact, as shown in Figure 5, stabilizer wing 500 may have a left half wing 504 that has a first sweep and a right half wing 502 that has a second sweep that is different than the first sweep. As an example, left half wing 504 may have a lower sweep than right half wing 502. If desired, left half wing 504 may have a higher sweep than right half wing 502.

As shown in Figure 5, stabilizer wing 500 may have an arc-shaped leading edge 510, an arc-shaped trailing edge 520, and a quarter chord line 540 with a non-zero curvature.

As an example, stabilizer wing 500 may have a constant chord length 550. If desired, chord length 550 may be constant at any span station  $Y$  (i.e., everywhere between  $Y = -1$  and  $Y = 1$ ). In this example, since stabilizer wing 500 has an arc-shaped leading edge 510 and a constant chord length 550 at any span station  $Y$ , leading edge 510, trailing edge 520 and quarter chord line 540 have the same arc shape and the same non-zero curvature.

However, since stabilizer wing 500 is asymmetrical to center line 530, left half wing 504 has a quarter chord line 540 with a first curvature, and right half wing 502 has a quarter chord line 540 with a second curvature, whereby the second curvature is different than the first curvature.

For example, right half wing 502 may have a higher curvature of quarter chord line 540 than left half wing 504. If desired, right half wing 502 may have a lower curvature of quarter chord line 540 than left half wing 504.

- 5           If desired, left half wing 504 may have a first length and right half wing 502 may have a second length that is different than the first length. In other words, one of left half wing 504 and right half wing 502 may contribute more than 50% to wing span 555. As an example, left half wing 504 may be shorter than right half wing 502.
- 10       As another example, right half wing 502 may be shorter than left half wing 504.

The lengths of right and left half wings 502, 504 may be selected to equalize the contribution of the aerodynamic loads on right and left half wings 502, 504 to the roll moment around the attachment of the stabilizer wing 500 (e.g., at the fin, the tailboom, or the fuselage of a rotorcraft). A reduction of either the static and/or the dynamic component of the aerodynamic load at the stabilizer wing's attachment may be determined based on structural needs.

15

If desired, stabilizer wing 500 may include winglets (e.g., winglets 138 of Figure 1). Winglets may increase the aerodynamic lift of stabilizer wing 500 without increasing the wing span 555.

20

Since the wing span 555 and, more particularly the length of the right and left half wings 502, 504, respectively, defines the effective lever arm for the roll moments at the attachment of stabilizer wing 500, and since the winglet orientation is perpendicular to the rotor tip vortex center lines 560, 570, 580, which limits the interaction between the rotor tip vortex center lines 560, 570, 580 and the winglets, the use of winglets has the potential to reduce oscillating

25

roll moments at the attachment of stabilizer wing 500 for a given target of aerodynamic lift.

The asymmetry in curvature of quarter chord line 540 and/or sweep between right half wing 502 and left half wing 504 may be exploited to further reduce unsteady aerodynamic loads on stabilizer wing 500.

For example, selecting a combination of a predetermined curvature of quarter chord line 540 and predetermined sweep for left and right half wings 504, 502 may allow to independently adjust the temporal sequence of the interactions between the rotor tip vortex center lines 560, 570, 580 along the span stations  $Y$  of the left and right half wings 504, 502 of stabilizer wing 500.

To explain the effect, a previously symmetric stabilizer wing may be considered turned by a certain angle  $\Psi$  compared to the center line of the fuselage, which results in an asymmetry of the sweep.

Figure 6 is a diagram of an illustrative stabilizer wing 600 having a quarter chord line 640 with a non-zero curvature and a wing center line 635 that is perpendicular to a series of rotor tip vortex center lines 660, 670, 680 in accordance with some embodiments.

By way of example, stabilizer wing 600 may have a tapered chord length 650. If desired, chord length 650 may decrease from the wing center line 635 towards the wing tips (i.e., the chord length 650 decreases with an increase in the distance from wing center line 635). In this example, leading edge 610, trailing edge 620, and quarter chord line 640 may all have a different arc shape and a different non-zero curvature.

As shown in Figure 6, stabilizer wing 600 may be symmetrical to wing center line 635. Since, wing center line 635 is turned by an angle  $\Psi$  compared to the center line 630 of the fuselage, stabilizer wing 600 may be asymmetrical to center line 630 of the fuselage.

5            Since wing center line 635 is perpendicular to the series of rotor tip vortex center lines 660, 670, 680, each one of rotor tip vortex center lines 660, 670, 680 arrive at both half wings of stabilizer wing 600 at the same time. Thereby, the bending moments around the wing center line 635 of stabilizer wing 600 are occurring temporally in  
10 phase.

As shown in Figure 6, stabilizer wing 600 may be turned compared to the center line 630 of the fuselage such that the rotor tip vortex center lines 660, 670, 680 are perpendicular to wing center line 635. The actual turning angle  $\psi$  between wing center line 635 and  
15 center line 630 of the fuselage may be dependent on the actual configuration of the rotorcraft.

As an example, an angle  $\psi$  between  $0^\circ$  and  $30^\circ$  may be selected for a rotorcraft having one main rotor that has a main rotor center at the center line 630 of the fuselage in front of stabilizer wing 600 and  
20 turns counter clockwise when looked upon from above. As another example, an angle  $\psi$  between  $0^\circ$  and  $-30^\circ$  may be selected for a rotorcraft having one main rotor that has a main rotor center at the center line 630 of the fuselage in front of stabilizer wing 600 and turns clockwise when looked upon from above.

25            The elasticity of the stabilizer wing 200, 300, 400, 500, or 600 shown in Figures 2 to 6 may affect the aerodynamic load, since the curvature of the quarter chord line 240, 340, 440, 540, 640 can lead to a coupled response in bending and torsion. Thus, a vertical flexing

of the stabilizer wing 200, 300, 400, 500, 600, due to the aerodynamic loads may be accompanied by an elastic twisting of the stabilizer wing around the Y axis. Providing a stabilizer wing that allows an elastic twisting and/or that has a twisted structure around the Y axis at the attachment of the stabilizer wing may reduce the aerodynamic loads, because the twisting may change the angles of attack and hence the aerodynamic loads on the stabilizer wing.

If desired, stabilizer wing 200, 300, 400, 500, or 600 of Figures 2 to 6 may have a twist, which is a variation of the angles between the chord lines and the horizontal XY plane for different span stations Y. In other words, stabilizer wing 200, 300, 400, 500, or 600 may have a variable incidence over at least a portion of the wing span.

If desired, stabilizer wings 200, 300, 400, 500, or 600 of Figures 2 to 6 may have a twist in addition to a quarter chord line 240, 340, 440, 540, or 640 with a non-zero curvature. The additional twist of stabilizer wings 200, 300, 400, 500, or 600 may compensate the asymmetric inflow situation on the left and right half wings of the respective stabilizer wing 200, 300, 400, 500, or 600.

Consider the scenario in which a rotor wake is not symmetrical relative to the center line of the fuselage. For example, as shown in Figure 5, a rotor wake that generates rotor tip vortex center lines 560, 570, 580 is not symmetrical to a plane defined by center line 530 of the fuselage and the Z axis.

In this scenario, the rotor tip vortex center lines 560, 570, 580 may lead to asymmetric average aerodynamic loads between the left half wing 504 and the right half wing 502 in case of a non-twisted horizontal stabilizer wing.

By way of example, stabilizer wing 500 may equalize the time average of the lift and root moment of the left and right half wings 504, 502 at the attachment of stabilizer wing 500 for the most relevant flight states (e.g., level forward flight) through the curved quarter chord line 540 and the variable incidence over the wing span 555, thereby reducing the combined static roll moment that is exerted by left and right half wings 504, 502 at the attachment of stabilizer wing 500.

If desired, the stabilizer wing 200, 300, 400, 500, 600 of Figures 2 to 6 may include a spanwise distribution of incidence angles. The spanwise distribution of incidence angles may reduce the risk of flow separation at the stabilizer wing's root. The danger of flow separation increases with the amount of negative pressure on a stabilizer wing.

Illustratively, the angle-of-attack may be reduced in direction from the wing tips of stabilizer wing 200, 300, 400, 500, or 600 of Figures 2 to 6 to the stabilizer wing's root in order to reduce the amount of negative pressure generated at the lower surface of the stabilizer wing's root.

The portion of the stabilizer wing's surface that is close to the stabilizer wing's root is particularly prone to flow separation if the stabilizer wing is mounted to the fin of a rotorcraft. In fact, a low-pressure field of the fin extends onto the stabilizer wing's surface part close to the stabilizer wing's root in addition to the low-pressure induced by the stabilizer wing itself.

The fin of a rotorcraft may provide antitorque against the torque of a rotor. For example, the fin may generate a force to the right (i.e., in positive Y direction) in a rotorcraft with a rotor that rotates counter

clockwise when seen from above. In fact, the force generated by the fin is achieved by a negative pressure on the right surface of the fin.

In this example, an incidence angle of zero degrees between the chord of the stabilizer wing and the XY plane may be on the right side of the fin (i.e., at a span station with a positive Y). If desired, the incidence angle between the chord of the stabilizer wing and the XY plane may continuously increase from the span station where the incidence angle is zero degrees towards the left wing tip (i.e., in negative Y direction) and continuously decrease from the span station where the incidence angle is zero degrees towards the right wing tip (i.e., in positive Y direction).

Alternatively, for a rotor rotating clockwise when seen from above, the left fin surface would be subjected to negative pressure. Accordingly, an incidence angle of zero degrees between the chord of the stabilizer wing and the XY plane may be on the left side of the fin (i.e., at a span station with a negative Y).

If desired, the incidence angle between the chord of the stabilizer wing and the XY plane may continuously increase from the span station where the incidence angle is zero degrees towards the right wing tip (i.e., in positive Y direction) and continuously decrease from the span station where the incidence angle is zero degrees towards the left wing tip (i.e., in negative Y direction).

The incidence angle distributions over the stabilizer wing span may be shifted as a whole along the ordinate (i.e., shifted along the Y axis to uniformly increase or decrease the incidence angle across the entire wing span), which does not change the variation along the abscissa (i.e., the twist along the X axis), but only the overall incidence and thus the lift of the complete stabilizer wing.

By way of example, the incidence angle may have a greater change towards the stabilizer wing's root than towards the stabilizer wing's tips. In other words, for a given incidence angle  $\theta$  and transversal axis  $Y$  from  $Y = -1$  at the left wing tip to  $Y = 1$  at the right wing tip of the stabilizer wing, the change in incidence angle  $d\theta/dY$  is greater than the mean twist (i.e.,  $(\theta(Y=-1) - \theta(Y=1))/2$ ) in the spanwise region  $Y = [-0.5...0.5]$ ,

Illustratively, the incidence angle distribution over the stabilizer wing span may have predetermined upper and lower boundaries. If desired, an actual incidence angle distribution over the stabilizer wing span may be selected that lies between the predetermined upper and lower boundaries. The selection of the actual incidence angle distribution over the stabilizer wing may be selected based on the predominant flight mode, for example.

It should be noted that the above-described embodiments are merely described to illustrate possible realizations of the present invention, but not in order to restrict the present invention thereto. Instead, multiple modifications and variations of the described embodiments are possible and should, therefore, also be considered as being part of the invention.

By way of example, asymmetrical stabilizer wing 500 of Figure 5 is shown with a constant chord length 550. However, asymmetrical stabilizer wing 550 may be tapered, if desired. Similarly, stabilizer wing 600 of Figure 6 is shown tapered. However, stabilizer wing 600 may have a constant chord length, if desired.

As another example, stabilizer wings 200, 300, 400, 500, 600 of Figures 2 to 6 are shown with a predetermined sweep. If desired, stabilizer wings 200, 300, 400, 500, 600 may have a different sweep.

For example, stabilizer wings 200, 300, 400, 500, 600 may have a greater sweep or a smaller sweep than shown in Figures 2 to 6.

Moreover, a lower bound for the absolute value of the non-zero curvature of the quarter chord line 240 of stabilizer wing 200 of Figure has been given as 0.2 (i.e.,  $|d^2/dY^2 (f(Y))| > 0.2$ ), and an upper bound for the absolute value of the non-zero curvature of the quarter chord line 240 has been given as 4 (i.e.,  $|d^2/dY^2 (f(Y))| < 4$ ).

However, the lower bound for the absolute value of the non-zero curvature of the quarter chord line 240 may be selected to be greater or smaller than 0.2. Similarly, the upper bound for the absolute value of the non-zero curvature of the quarter chord line 240 may be selected to be greater or smaller than 4. If desired, the lower and upper bounds for the absolute value of the non-zero curvature of the quarter chord line 240 may be selected based on the shape of the rotor tip vortex center lines.

Similarly, the absolute value of the non-zero curvature of the quarter chord line 240 may have an upper limit based on the distance from center line 230 and the factor by which the upper limit decreases may be a factor A which may be selected from the interval  $]0; B[$ , with B being the upper bound for the absolute value of the non-zero curvature of the quarter chord line 240. For example, the absolute value of the non-zero curvature of the quarter chord line 240 may be smaller than  $B - (B-C)*|Y|$  with  $B \in [1; 4]$  and  $C \in [0; 1]$  (i.e.,  $|d^2/dY^2 (f(Y))| < B - (B-C)*|Y|$ ).

25

## Reference List

- 100 rotorcraft
- 102 main rotor
- 102a, 102b, 102c, 102d, 102e rotor blades
- 5 103 main rotor center
- 103a rotor mast axis
- 104 fuselage
- 104a cabin
- 107 fuselage nose
- 10 108 nose region
- 109 aft region
- 121 tail boom
- 122 tail rotor
- 130 center line
- 15 131 fin
- 132 rudder
- 133 tail wing, stabilizer wing
- 136 leading edge
- 137 trailing edge

	138	winglet
	160	wing tip
	200	stabilizer wing
	210	leading edge
5	220	trailing edge
	230	center line
	240	quarter chord line
	250	chord length
	255	wing span
10	257	half wing span (left half wing)
	258	half wing span (right half wing)
	260	wing tip
	270	distance
	272, 274, 276, 278	points on quarter chord line
15	282	distance amounting to 10% of the wing span
	284	distance amounting to 30% of the wing span
	286	distance amounting to 50% of the wing span
	288	distance amounting to 70% of the wing span
	290	straight line

- 300 stabilizer wing
- 310 leading edge
- 320 trailing edge
- 330 center line
- 5 340 quarter chord line
- 360, 370, 380 rotor tip vortex center line
- 400 stabilizer wing
- 410 leading edge
- 420 trailing edge
- 10 430 center line
- 440 quarter chord line
- 450 chord length
- 457 wing tip
- 460, 470, 480 rotor tip vortex center line
- 15 500 stabilizer wing
- 502 right half wing
- 504 left half wing
- 510 leading edge
- 520 trailing edge

	530	center line
	540	quarter chord line
	550	chord length
	555	wing span
5	560, 570, 580	rotor tip vortex center line
	600	stabilizer wing
	610	leading edge
	620	trailing edge
	630	fuselage center line
10	635	wing center line
	640	quarter chord line
	650	chord length
	660, 670, 680	rotor tip vortex center line
	X	longitudinal axis, length axis
15	Y	transversal axis, lateral axis, width axis
	Z	vertical axis, height axis

**CLAIMS**

1. A helicopter, comprising:
  - a fuselage having a center line;
  - 5 a main rotor that generates vortices during operation; and
  - a stabilizer wing connected to the fuselage, the stabilizer comprising (i) a left wing tip, (ii) a right wing tip, (iii) a quarter chord line, (iv) a leading edge that is arc-shaped, and (v) a trailing edge that is arc-shaped;
  - 10 wherein the quarter chord line has a non-zero curvature to reduce unsteady aerodynamic loads caused by a wake of the main rotor on the stabilizer wing compared to a stabilizer wing having a straight quarter chord line such that an interaction between vortices generated by the main rotor and the quarter chord line is spread
  - 15 out over time.
  
2. The helicopter of claim 1, wherein the fuselage extends in a longitudinal direction between a nose region and an aft region, and wherein the quarter chord line of the stabilizer wing is closer to the
- 20 aft region at at least one of the left or right wing tip than at the center line of the fuselage.
  
3. The helicopter of claim 1, wherein the fuselage extends in a longitudinal direction between a nose region and an aft region, and
- 25 wherein the quarter chord line of the stabilizer wing is closer to the nose region at at least one of the left or right wing tip than at the center line of the fuselage.
  
4. The helicopter of any one of claims 1 to 3, wherein an
- 30 absolute value of the non-zero curvature of the quarter chord line is greater than 0.2, and wherein the quarter chord line is a function and the curvature is the second derivative of the function.

5. The helicopter of claim 4, wherein the absolute value of the non-zero curvature of the quarter chord line is smaller than 4.

5 6. The helicopter of any one of claims 1 to 5, wherein the non-zero curvature of the quarter chord line evolves from a first value at a first distance from the center line of the fuselage to a second value at a second distance from the center line of the fuselage such that the non-zero curvature of the quarter chord line is non-constant between the first and second distance from the center line  
10 of the fuselage.

7. The helicopter of any one of claims 1 to 6, wherein the stabilizer wing has a half wing span between the center line and a wing tip of the left or right wing tips, wherein first, second, third, and fourth points are located on the quarter chord line at first, second, third, and fourth distances from the center line of the fuselage, respectively, wherein the first, second, third, and fourth distances amount to 10%, 30%, 50%, and 70% of the half wing span, respectively, wherein the non-zero curvature of the quarter chord line is non-zero between the first and fourth points and wherein a straight line between the first and fourth points has a fifth distance from the quarter chord line between the second and third points that is greater than 2% of the half wing span.  
20

25

8. The helicopter of any one of claims 1 to 7, wherein the quarter chord line is symmetrical to the center line of the fuselage.

9. The helicopter of any one of claims 1 to 8, wherein the stabilizer wing is mounted to at least one of the fuselage, a tail boom that is attached to the fuselage, or a vertical fin that is attached to the tail boom.  
30

10. The helicopter of any one of claims 1 to 9, wherein the stabilizer wing has a constant chord length between the left and right wing tips of the stabilizer wing.

5

11. The helicopter of any one of claims 1 to 9, wherein the stabilizer wing has a chord length that decreases from the center line of the fuselage towards the left and right wing tips of the stabilizer wing.

10

12. The helicopter of any one of claims 1 to 7, wherein the stabilizer wing comprises a left half wing having a first sweep and a right half wing having a second sweep that is different than the first sweep.

15

13. The helicopter of claim 12, wherein the left half wing has a quarter chord line with a first curvature, wherein the right half wing has a quarter chord line with a second curvature, and wherein the second curvature is different than the first curvature.

20

14. The helicopter of claim 12, wherein the left half wing has a first length and the right half wing has a second length that is different than the first length.

25

15. The helicopter of any one of claims 1 to 14, wherein the stabilizer wing comprises winglets.

16. The helicopter of any one of claims 1 to 15, wherein the main rotor is the only rotor to provide lift during operation.

30

17. A helicopter, comprising:  
a fuselage having a center line;

a main rotor that generates vortices during operation; and  
a stabilizer wing connected to the fuselage, the stabilizer comprising (i) a left wing tip, (ii) a right wing tip, (iii) a quarter chord line, (iv) a leading edge that is arc-shaped, (v) a trailing edge that is arc-shaped, (vi) a left half wing having a first sweep and (vii) a right half wing having a second sweep that is different than the first sweep;  
wherein the quarter chord line has a non-zero curvature to reduce unsteady aerodynamic loads caused by a wake of the main rotor on the stabilizer wing compared to a stabilizer wing having a straight quarter chord line such that an interaction between vortices generated by the main rotor and the quarter chord line is spread out over time;  
wherein the left half wing has a quarter chord line with a first curvature;  
wherein the right half wing has a quarter chord line with a second curvature; and  
wherein the second curvature is different than the first curvature.

18. A helicopter, comprising:  
a fuselage having a center line;  
a main rotor that generates vortices during operation; and  
a stabilizer wing connected to the fuselage, the stabilizer comprising (i) a left wing tip, (ii) a right wing tip, (iii) a quarter chord line, (iv) a leading edge that is arc-shaped, (v) a trailing edge that is arc-shaped, (vi) a left half wing having a first sweep and (vii) a right half wing having a second sweep that is different than the first sweep;  
wherein the quarter chord line has a non-zero curvature to reduce unsteady aerodynamic loads caused by a wake of the main rotor on the stabilizer wing compared to a stabilizer wing having a straight quarter chord line such that an interaction between vortices

generated by the main rotor and the quarter chord line is spread out over time; and

wherein the left half wing has a first length and the right half wing has a second length that is different than the first length.

5

19. The helicopter of claim 17 or 18, wherein the fuselage extends in a longitudinal direction between a nose region and an aft region, and wherein the quarter chord line of the stabilizer wing is closer to the aft region at at least one of the left or right wing tip than at the center line of the fuselage.

10

20. The helicopter of claim 17 or 18, wherein the fuselage extends in a longitudinal direction between a nose region and an aft region, and wherein the quarter chord line of the stabilizer wing is closer to the nose region at at least one of the left or right wing tip than at the center line of the fuselage.

15

21. The helicopter of claim 17 or 18, wherein an absolute value of the non-zero curvature of the quarter chord line is greater than 0.2, and wherein the quarter chord line is a function and the curvature is the second derivative of the function.

20

22. The helicopter of claim 21, wherein the absolute value of the non-zero curvature of the quarter chord line is smaller than 4.

25

23. The helicopter of claim 17 or 18, wherein the non-zero curvature of the quarter chord line evolves from a first value at a first distance from the center line of the fuselage to a second value at a second distance from the center line of the fuselage such that the non-zero curvature of the quarter chord line is non-constant between the first and second distance from the center line of the fuselage.

30

24. A helicopter, comprising:  
a fuselage having a center line;  
a main rotor that generates vortices during operation; and  
5 a stabilizer wing connected to the fuselage, the stabilizer comprising (i) a left wing tip, (ii) a right wing tip, (iii) a quarter chord line having a curvature, (iv) a leading edge that is arc-shaped, and (v) a trailing edge that is arc-shaped;  
wherein the quarter chord line is a function and the curvature is a  
10 second derivative of the function; and  
wherein, an absolute value of the curvature of the quarter chord line is between -0.9 and -0.1 or between 0.1 and 4 for reducing unsteady aerodynamic loads generated by a wake of the main rotor and for spreading out over time vortices generated by the main  
15 rotor on the stabilizer wing.

25. The helicopter of claim 24, wherein the fuselage extends in a longitudinal direction between a nose region and an aft region, and wherein the quarter chord line of the stabilizer wing is closer to the  
20 aft region at at least one of the left or right wing tip than at the center line of the fuselage.

26. The helicopter of claim 24, wherein the fuselage extends in a longitudinal direction between a nose region and an aft region, and  
25 wherein the quarter chord line of the stabilizer wing is closer to the nose region at at least one of the left or right wing tip than at the center line of the fuselage.

27. The helicopter of any one of claims 24 to 26, wherein the  
30 non-zero curvature of the quarter chord line evolves from a first value at a first distance from the center line of the fuselage to a second value at a second distance from the center line of the

fuselage such that the non-zero curvature of the quarter chord line is non-constant between the first and second distance from the center line of the fuselage.

5 28. The helicopter of any one of claims 24 to 27, wherein the  
stabilizer wing has a half wing span between the center line and a  
wing tip of the left or right wing tips, wherein first, second, third,  
and fourth points are located on the quarter chord line at first,  
second, third, and fourth distances from the center line of the  
10 fuselage, respectively, wherein the first, second, third, and fourth  
distances amount to 10%, 30%, 50%, and 70% of the half wing  
span, respectively, wherein the non-zero curvature of the quarter  
chord line is non-zero between the first and fourth points and  
wherein a straight line between the first and fourth points has a  
15 fifth distance from the quarter chord line between the second and  
third points that is greater than 2% of the half wing span.

29. The helicopter of any one of claims 24 to 28, wherein the  
quarter chord line is symmetrical to the center line of the fuselage.

20

Fig. 1A

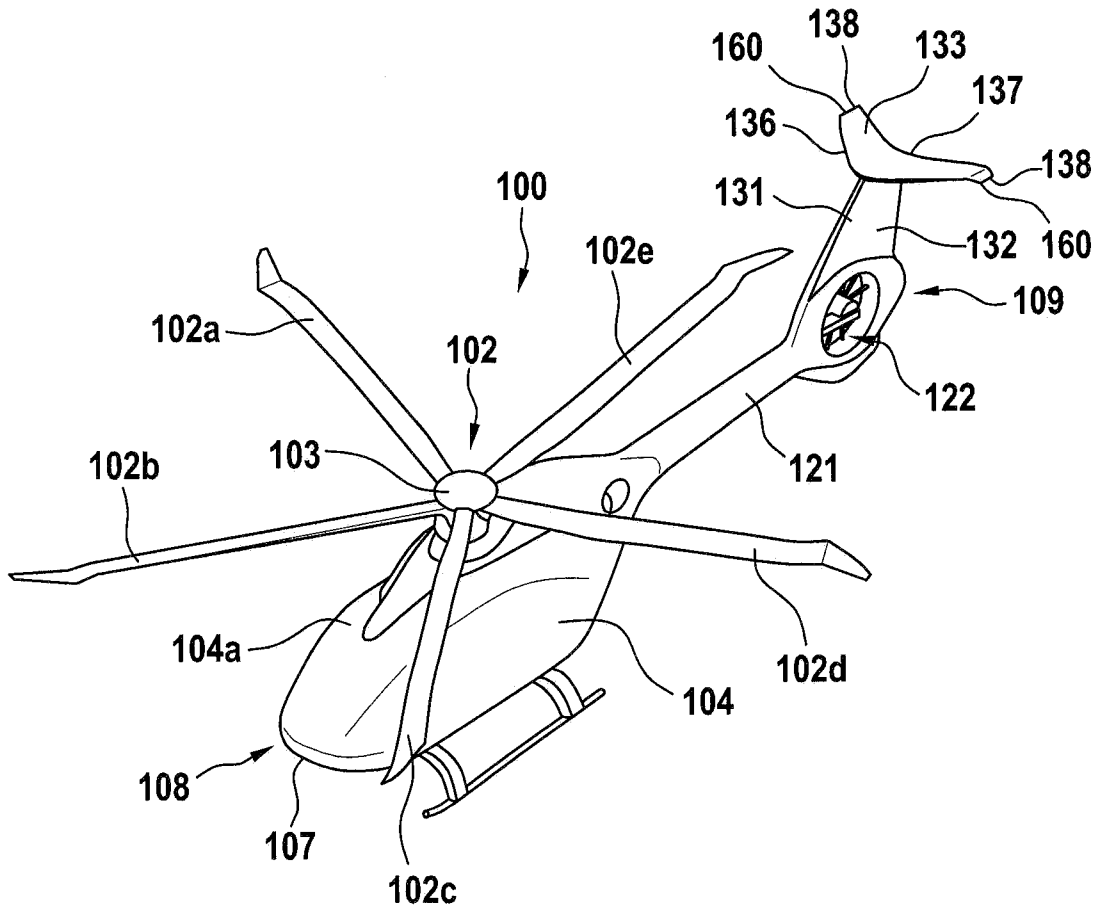

Fig. 1B

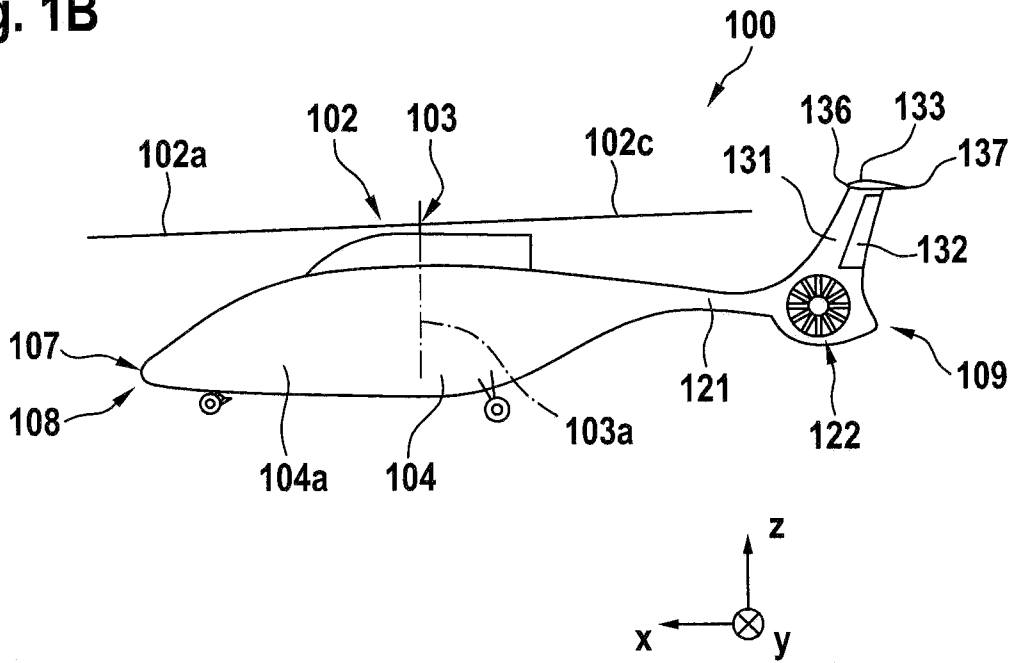

Fig. 1C

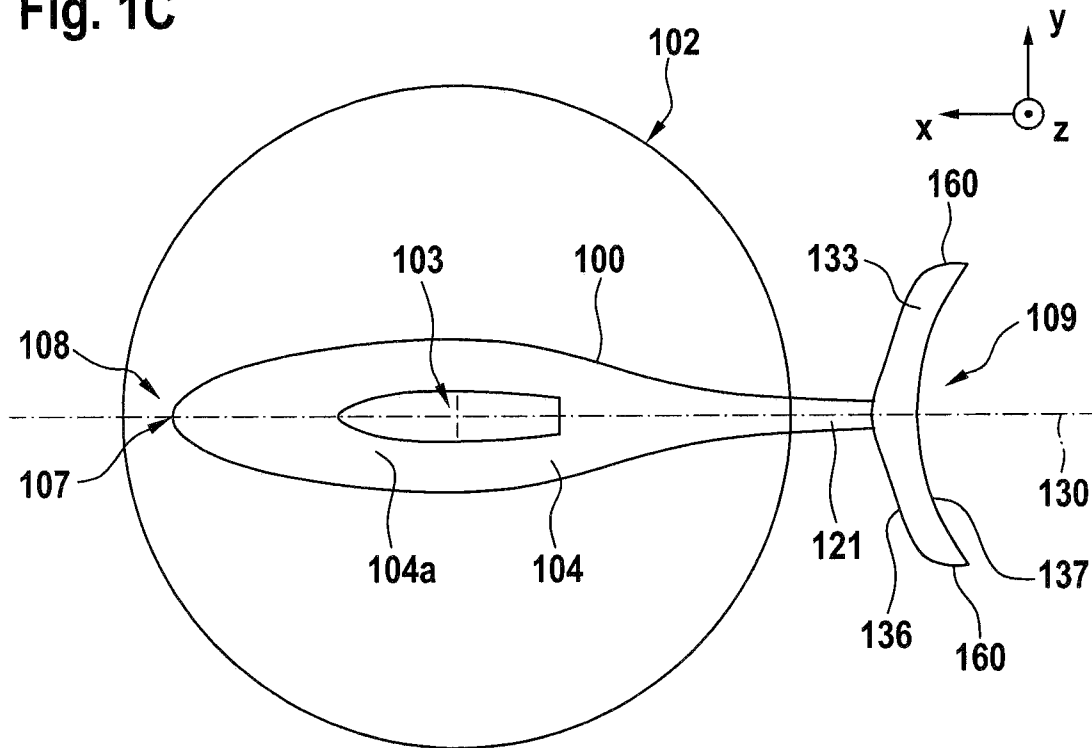

Fig. 2

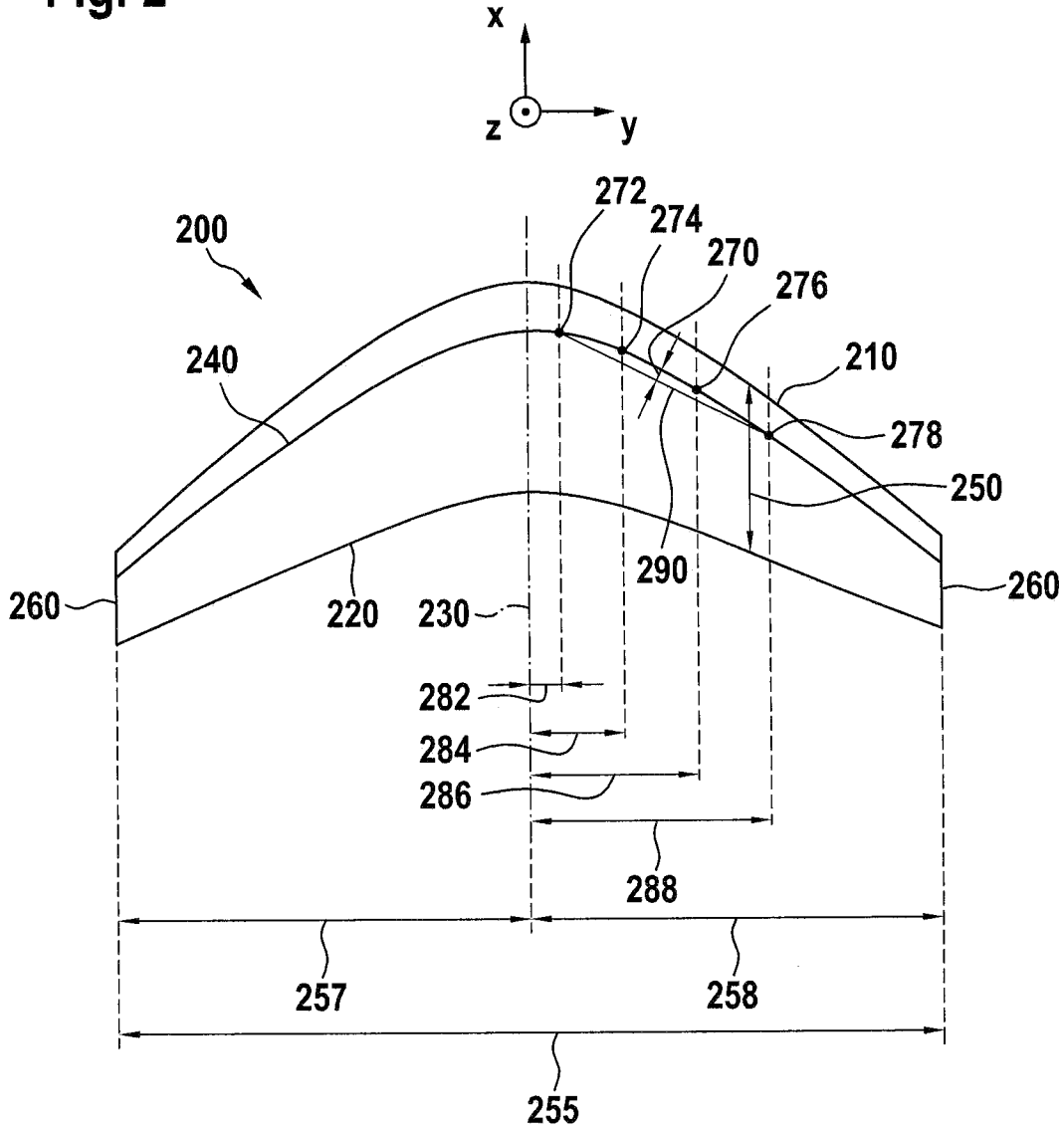

Fig. 3A

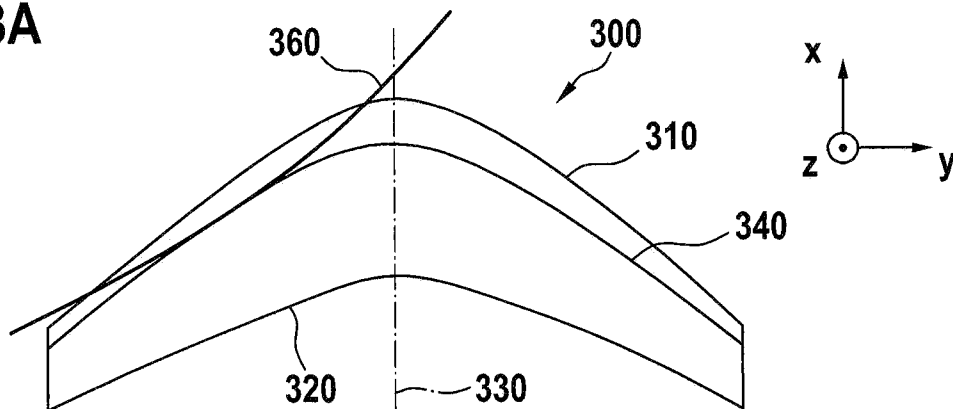

Fig. 3B

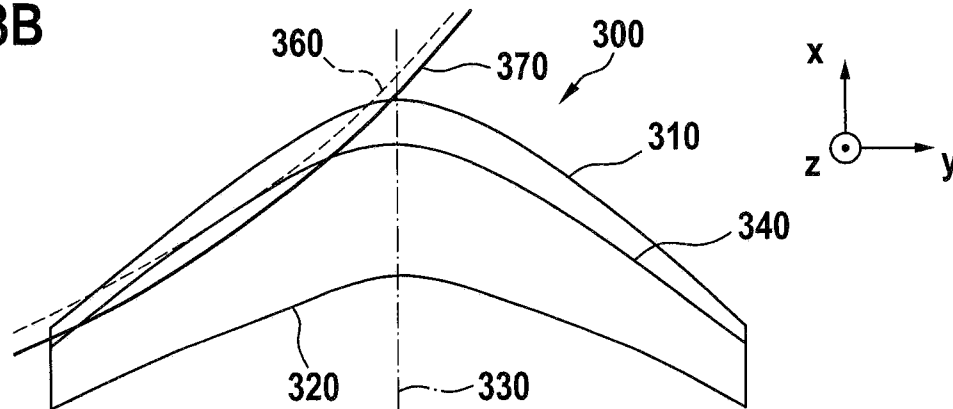

Fig. 3C

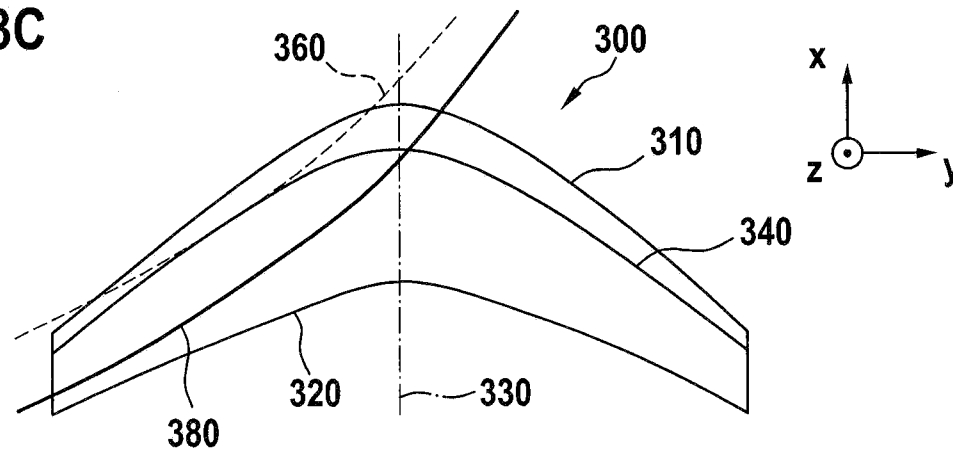

Fig. 4

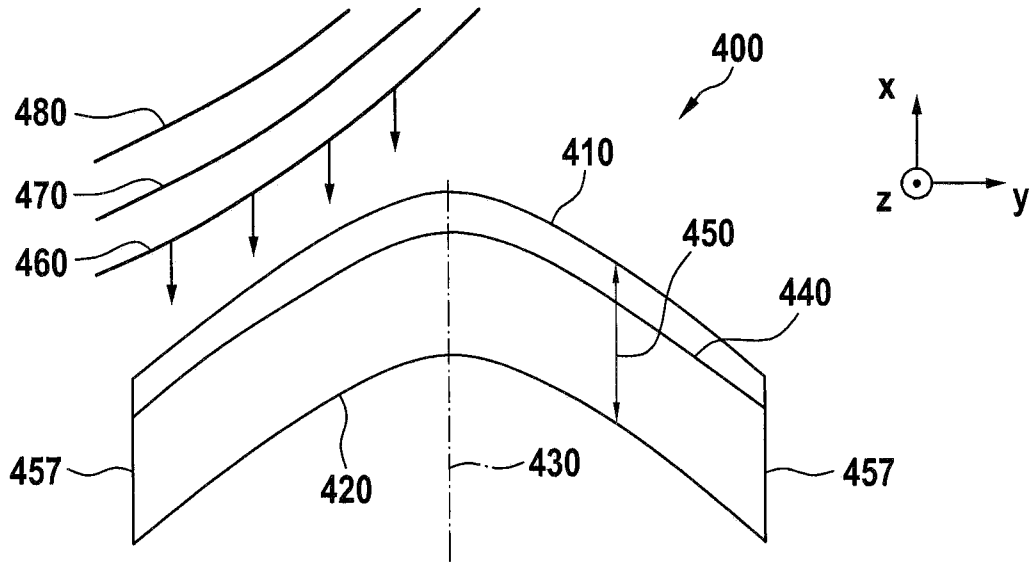

Fig. 5

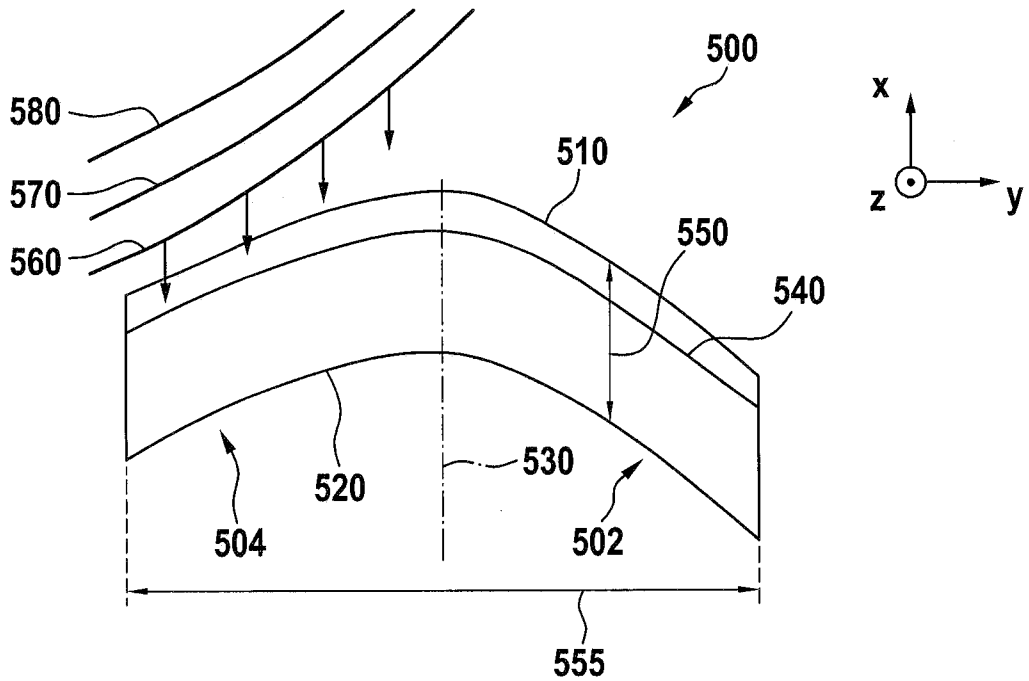

Fig. 6

