



US 20110079604A1

(19) **United States**

(12) **Patent Application Publication**
DELUCIA

(10) **Pub. No.: US 2011/0079604 A1**

(43) **Pub. Date: Apr. 7, 2011**

(54) **CUBEKIOSK**

(52) **U.S. Cl. 221/92; 348/143; 348/E07.085**

(76) **Inventor: DONALD B. DELUCIA, BOCA RATON, FL (US)**

(57) **ABSTRACT**

(21) **Appl. No.: 12/924,464**

(22) **Filed: Sep. 28, 2010**

An open merchandise, multi-cubicle display, vending kiosk, custom fabricated from a plurality of visually open materials and sizes to suit the products being sold which provides a self-service customer purchase via either a barcode scan, or touch selector, payment facilitators, receipt printer and integrated computer assembly with special software programming. Also incorporated are audio components which attract customers to the kiosk and webcam video devices which observes the kiosk environment, serve the kiosk's security and can provide customer inquiries to a remote manager via VoIP communication features. Wireless internet components connect the kiosk functions whenever necessary, to process financial transaction services, or to a remote manager for the kiosk's inventory, records management and programming functions. In addition to its vending attributes, the kiosk also has a full closure curtain with a tubular motor which secures the kiosk after business hours.

Related U.S. Application Data

(60) **Provisional application No. 61/248,477, filed on Oct. 4, 2009.**

Publication Classification

(51) **Int. Cl.**
G07F 7/00 (2006.01)
H04N 7/18 (2006.01)

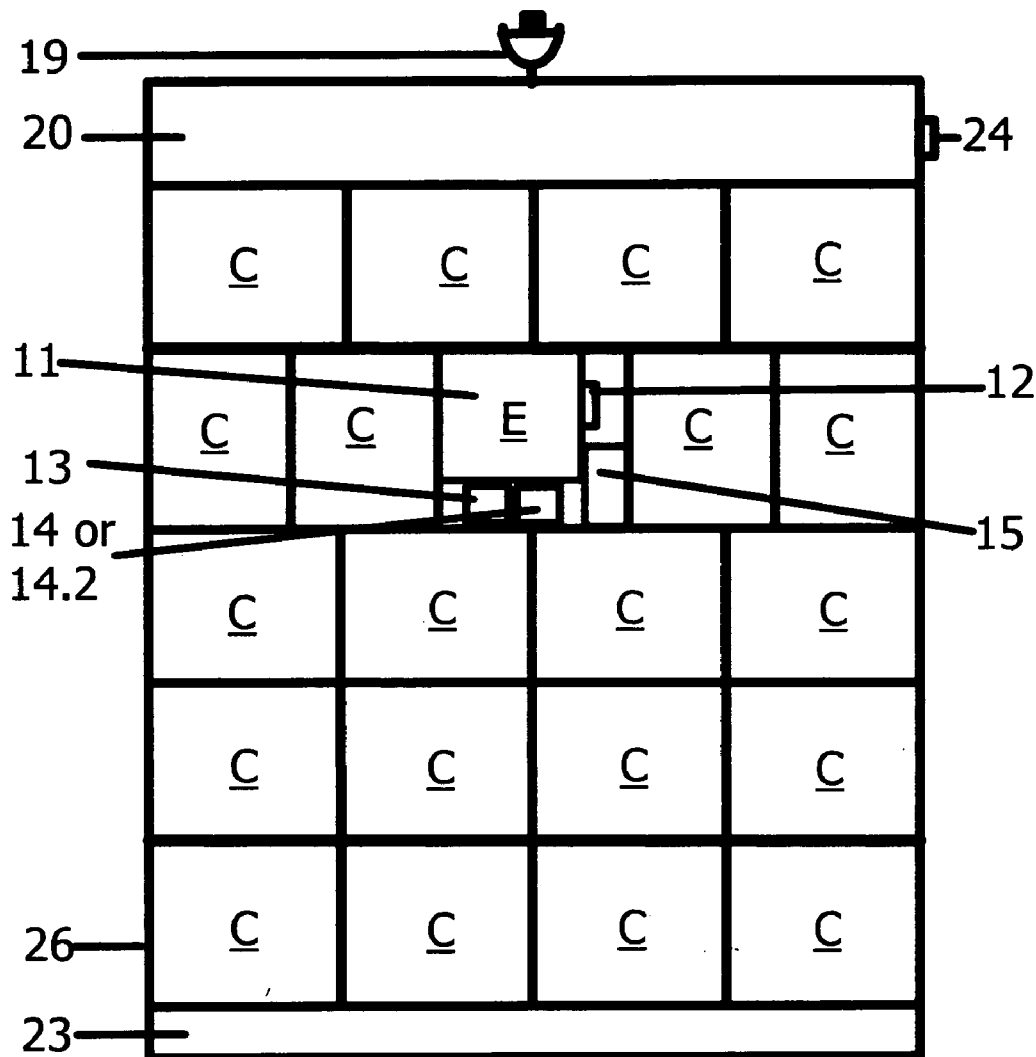

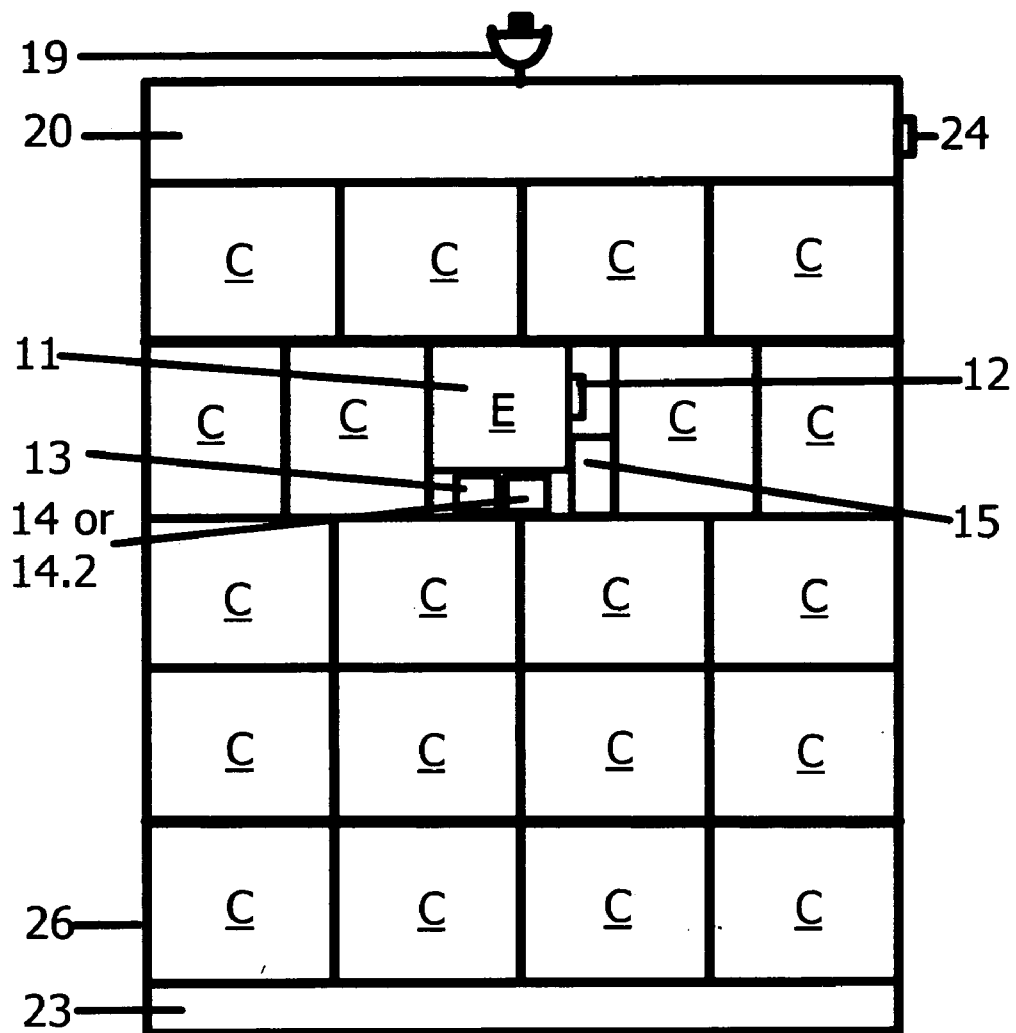

Fig. 1

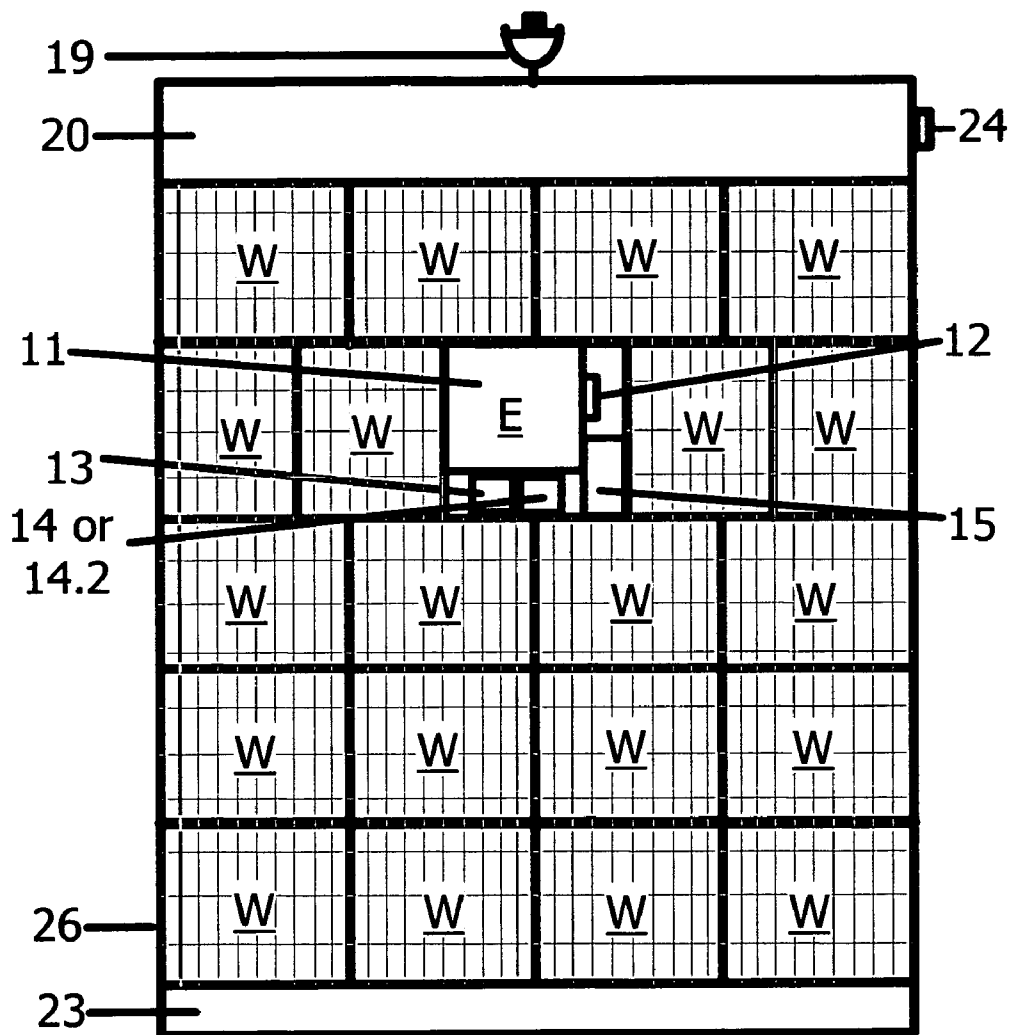

Fig. 2

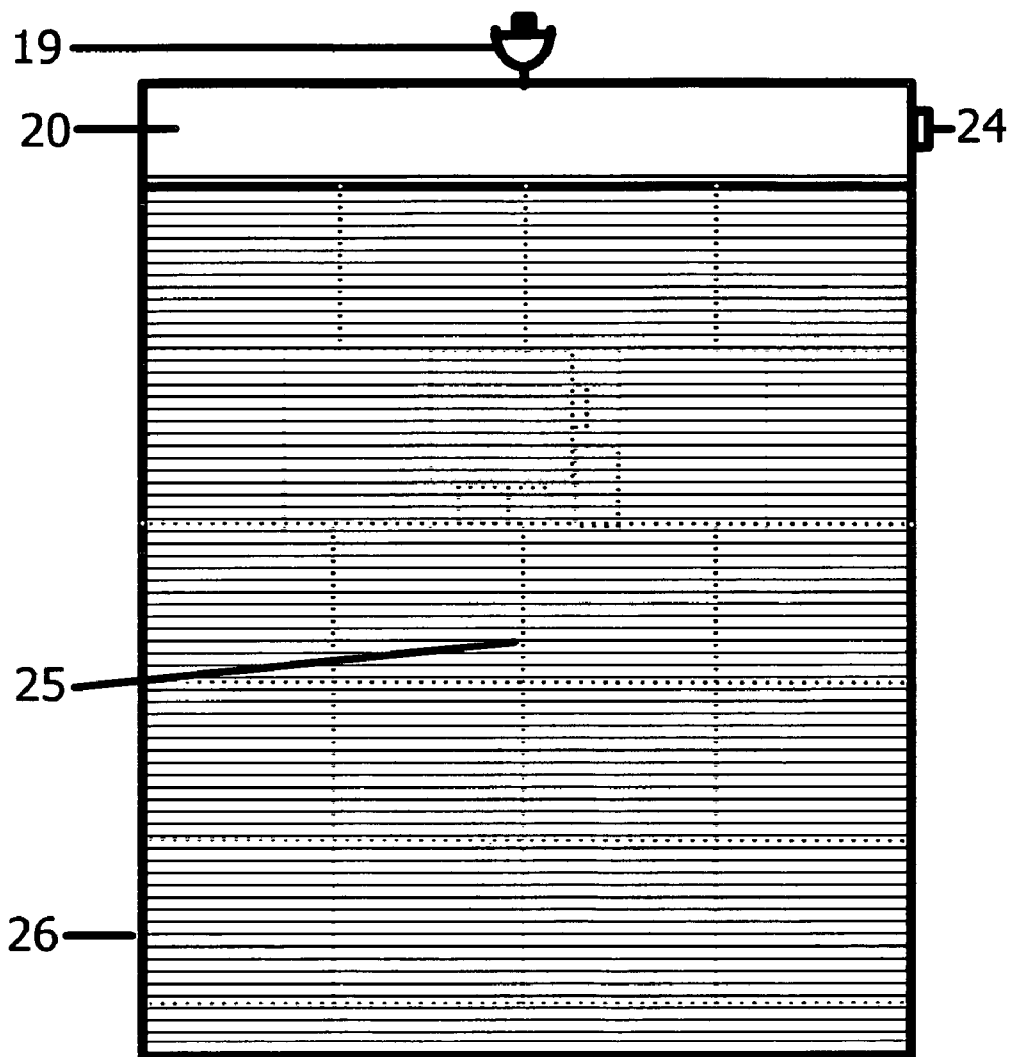

Fig. 3

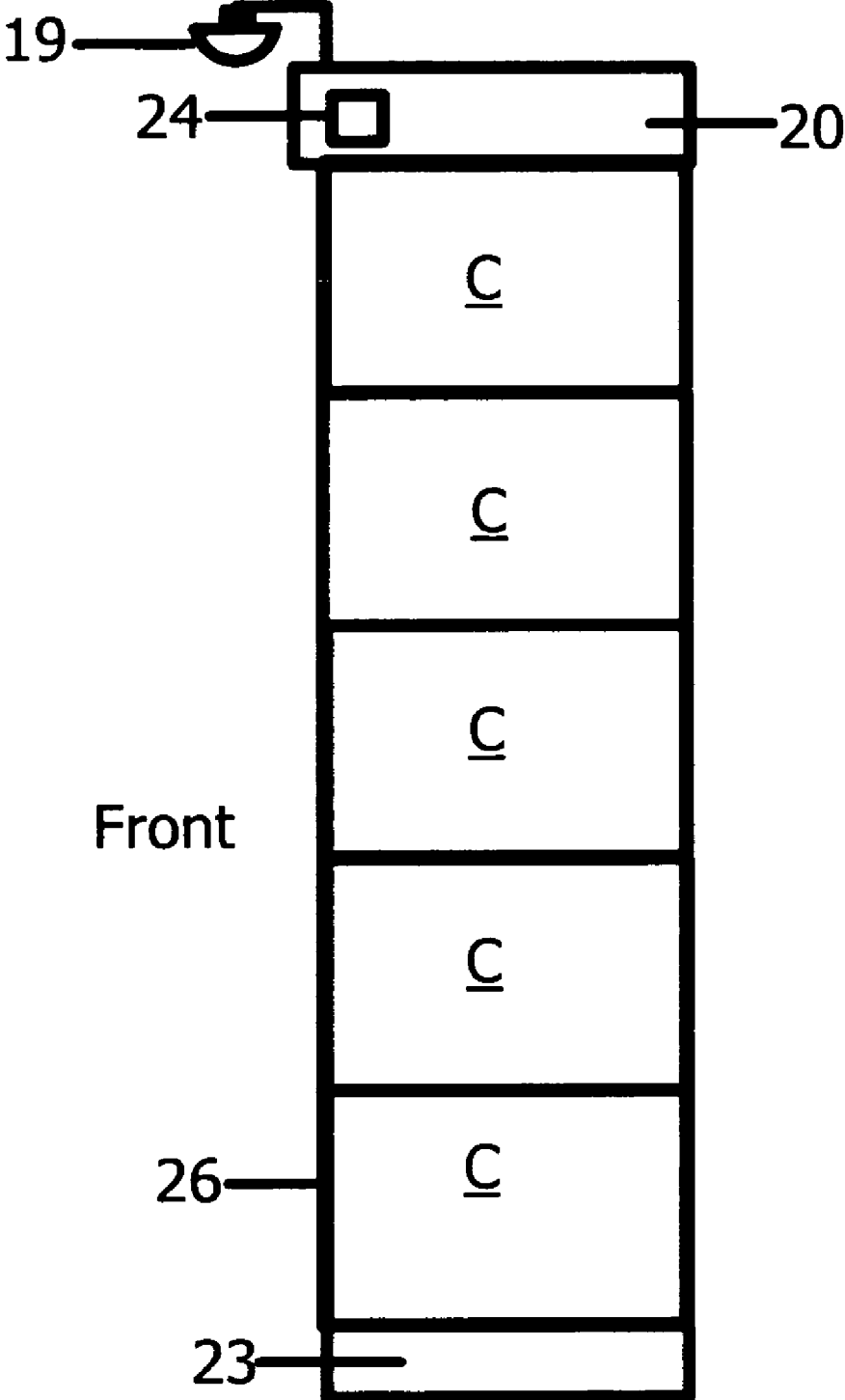

Fig. 4

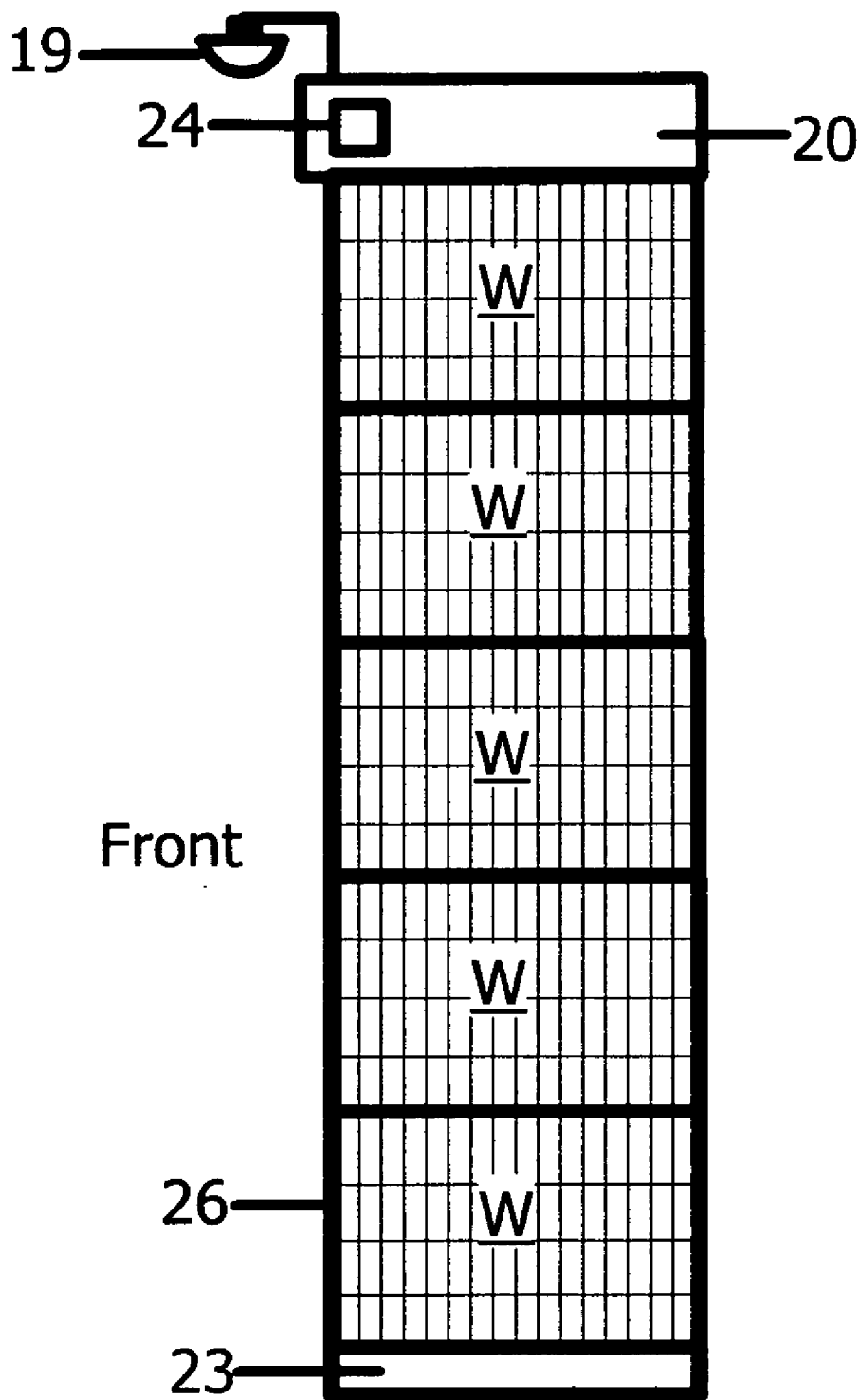

Fig. 5

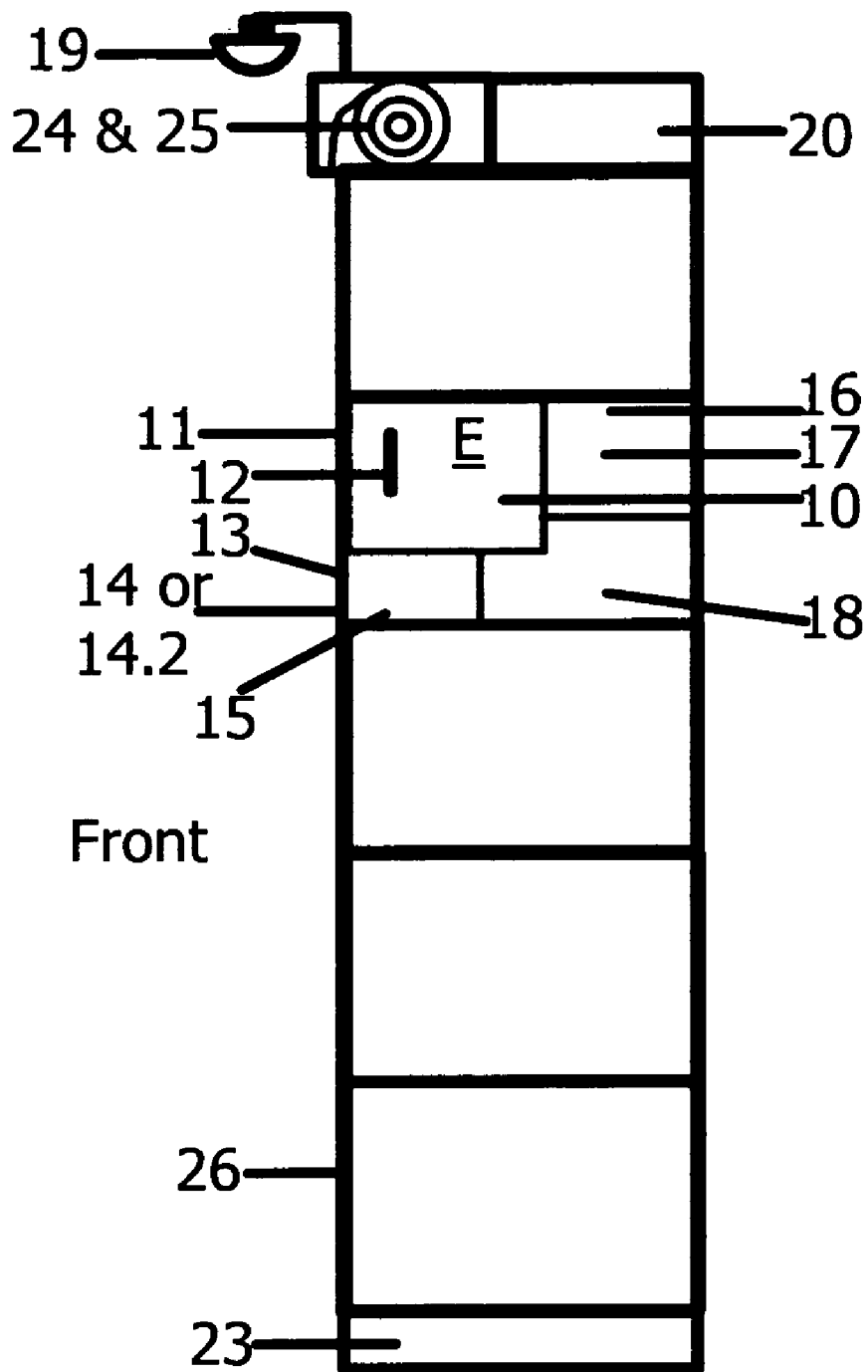

Fig. 6

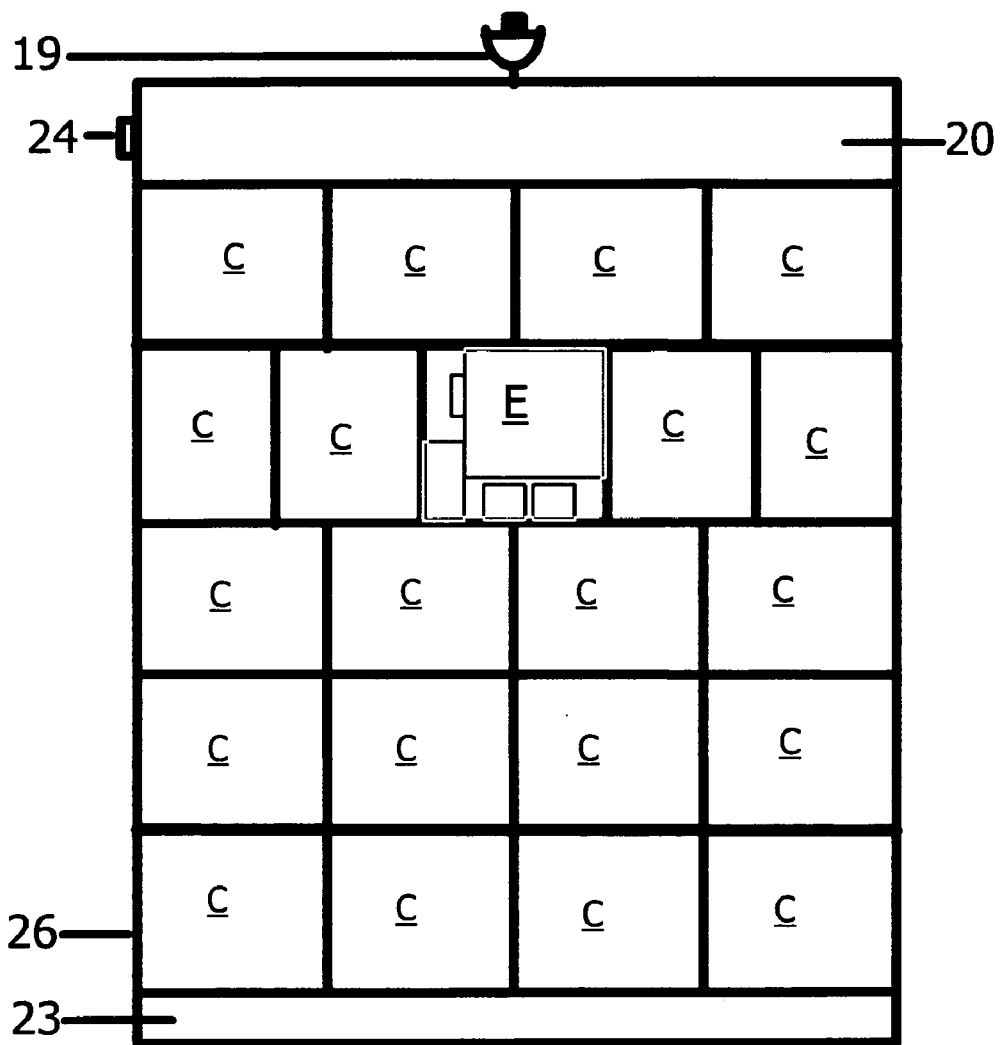

Fig. 7

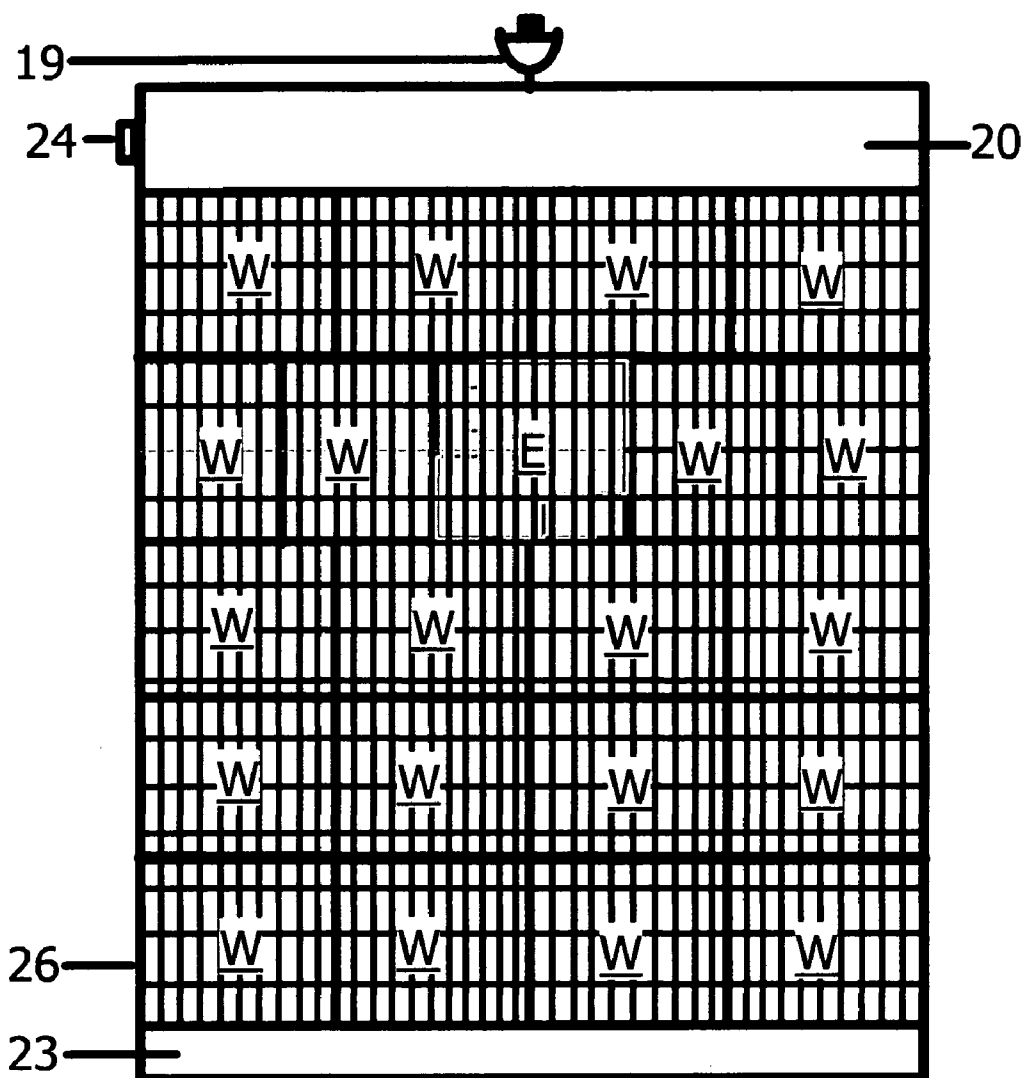

Fig. 8

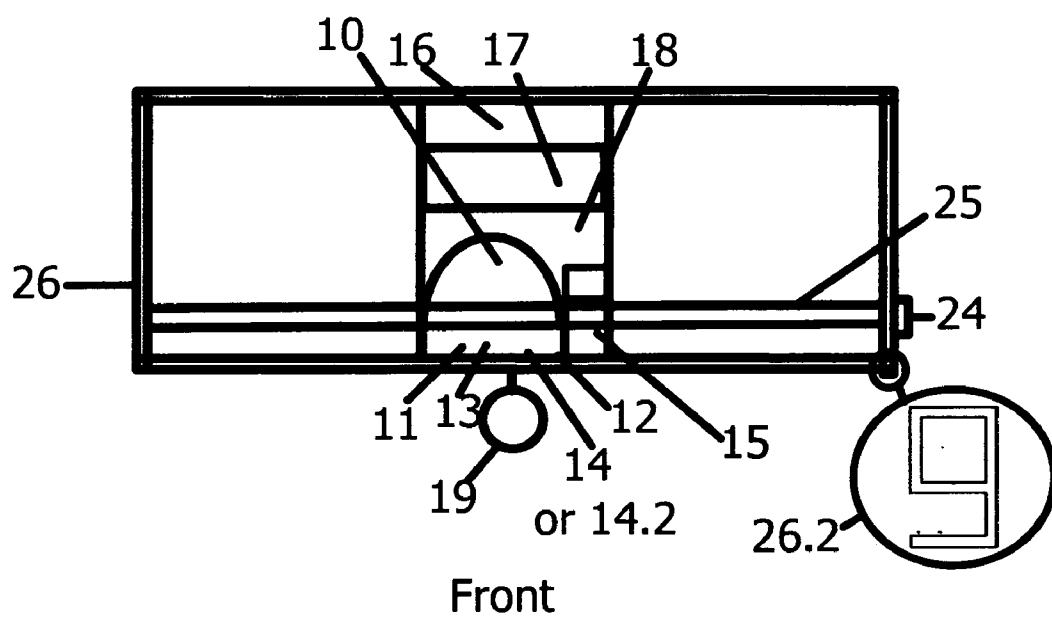

Fig. 9

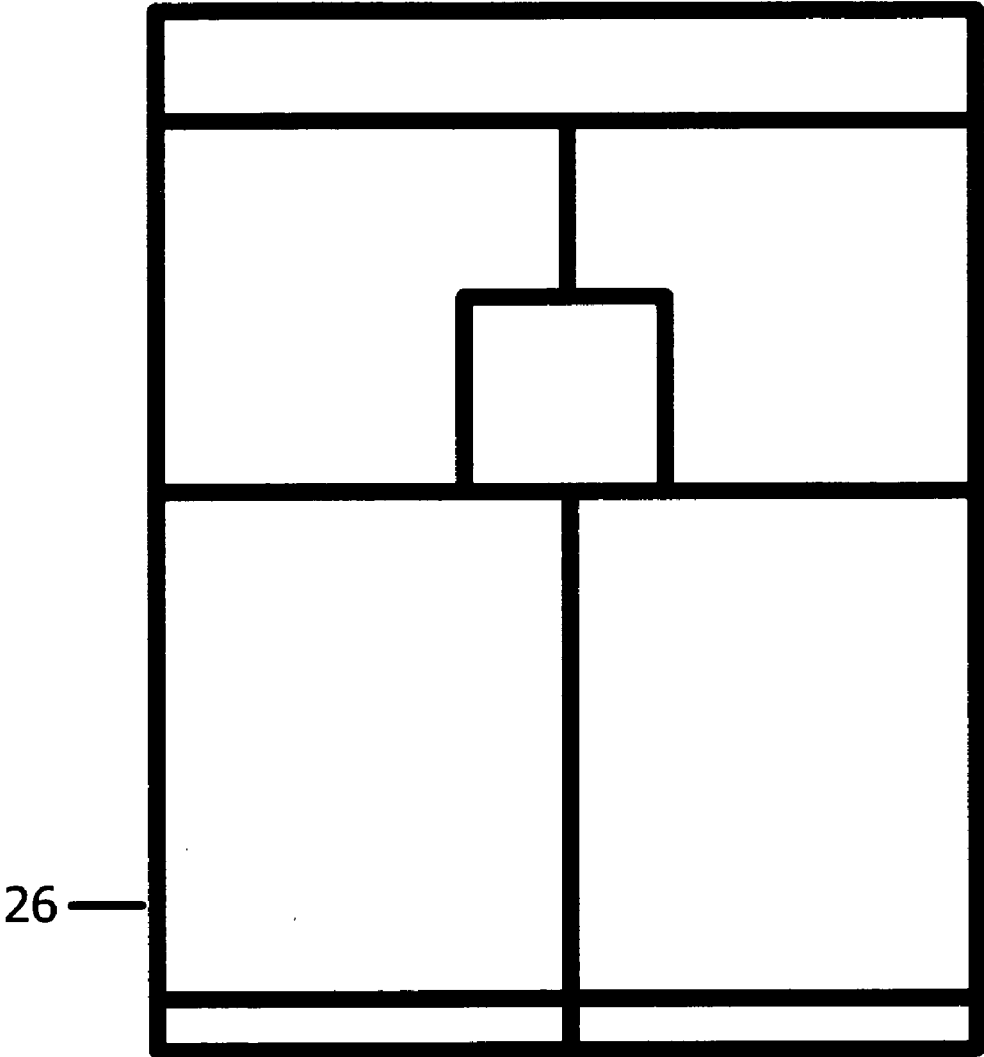

Fig. 10

CUBEKIOSK

CROSS-REFERENCE TO RELATED APPLICATIONS

[0001] This application claims the priority of U.S. Provisional Application No. 61/248,477 previously entitled "Display Touch Kiosk" filed on Oct. 4, 2009, the entire contents and substance of which is hereby incorporated in total by reference.

STATEMENT REGARDING FEDERALLY SPONSORED RESEARCH OR DEVELOPMENT

[0002] None

REFERENCE TO SEQUENCE LISTING, A TABLE, OR COMPUTER PROGRAM LISTING COMPACT DISC APPENDIX

[0003] None

BACKGROUND OF THE INVENTION

[0004] This invention is in the technical field of merchandise vending kiosk, but is unlike vending machines, or vending kiosks which have products seen or unseen and encapsulated within a closed structure, or vending devices which have electro-mechanical product delivery methods.

[0005] This vending kiosk invention provides an open merchandise, self-service sale and product delivery transaction without the need for a sales clerk, or cash register employee.

[0006] A typical application of this invention would be to serve as a plush toy display vending kiosk in a children's hospital gift shop, or other location where attending sales staff may be in short supply.

BRIEF SUMMARY OF THE INVENTION

[0007] This invention utilizes a plurality of open merchandise display cubes, integrated with a barcode scanner, touch selector, financial transaction facilitator, audio and video components and computer assembly in concert with a purchaser's self-service delivery action to vend products.

BRIEF DESCRIPTION OF THE SEVERAL VIEWS OF THE DRAWINGS

[0008] FIG. 1 is a front view of the present invention in a 21 cube, optional clear acrylic material style;

[0009] FIG. 2 is a front view of the present invention in a 21 cube, optional rigid wire mesh material style;

[0010] FIG. 3 is a front view of the present invention with a full closure security curtain closed over a 21 cube kiosk which could be either an optional clear acrylic, or rigid wire mesh material cube style;

[0011] FIG. 4 is a side view of the present invention with optional clear acrylic material style cubes;

[0012] FIG. 5 is a side view of the present invention with optional rigid wire mesh material style cubes;

[0013] FIG. 6 is a side cut-a-way composite elements view of the present invention which could be in either an optional clear acrylic, or rigid wire mesh material cube style;

[0014] FIG. 7 is a back view of the present invention with optional clear acrylic material style cubes;

[0015] FIG. 8 is a back view of the present invention with optional rigid wire mesh material style cubes;

[0016] FIG. 9 is an open top down cut-a-way composite elements view of the present invention which could be in either an optional clear acrylic, or rigid wire mesh material cube style;

[0017] FIG. 10 is a front view of the present invention's typical structural skeletal frame design.

DETAILED DESCRIPTION OF THE INVENTION

[0018] The present invention is an open merchandise vending kiosk which is custom designed in a plurality of styles consisting of a multi-cubicle, varying in size, touchable product display and storage structure, combined with a touch screen display selector, barcode scanner, point of sale transaction payment facilitator, webcam, VoIP/video phone, wireless internet modem, relays and related components, all of which are controlled via an on-board integrated computer assembly with special operating software.

[0019] Also incorporated into the invention are audio marketing devices designed to attract purchasers to the displayed merchandise with unique sounds, digital signage capabilities and visual display graphics components. The kiosk's audio and video features can; transmit a real time visual image of a customer and status of a sale, or interact with a product purchaser, or communicate a customer's inquiry, or transmit the kiosk's operating environment and operations status to a remote manager.

[0020] The invention also has a motorized, rollable full closure curtain covering which secures the merchandise display and kiosk's electronic components after business hours.

[0021] During the course of this description like numbers will be used to identify like elements according to the different views which illustrate the invention. This application considers and refers to the optional kiosk design decisions for the walls, sides, security curtain, cube sizes, skeletal frame design, overall size and all materials as kiosk 'styles'.

[0022] Referring now to the invention in further detail in FIGS. 1 and 2, there is shown a rectangle kiosk display structure with a plurality of front open internal cubicles, types C and W, which hold and display touchable merchandise products and are made from a plurality of optional materials held by a structural skeletal frame, FIGS. 1 thru 10, element 26 which is also made from a plurality of materials.

[0023] In more detail, the kiosk's cubes may be a clear solid material style, FIGS. 1, 4 and 7, cube type C, whereby the bottom, sides, back and top of the kiosk cubes can be made of a plurality of visually clear, solid materials such as, but not limited to: glass, plexiglass, or other acrylic and the like.

[0024] In more detail, another style for the kiosk's cubes bottom, sides, back and top may be made with a plurality of visually open, rigid wire mesh sizes and materials, FIGS. 2, 5 and 8, cube type W, such as, but not limited to: aluminum, composite, sturdy plastic, stainless steel, or other metal and the like, being either painted, or not.

[0025] The kiosk's structure is a composite of multiple internal cubes which are constructed in a self-supporting horizontal and vertical design and are also fastened together and held within a custom fabricated structural skeletal frame, FIGS. 1 thru 10, element 26, whereby the stacked formations of the combined rectangle cubicles attached to the frame become the kiosk unit.

[0026] The display cubicles and other elements of the kiosk structure are fastened together in a plurality of ways with a

plurality of materials, such as but not limited to: adhesives, epoxies, welds, screws, metal clips, and the like depending on the kiosk material style used.

[0027] In more detail, the kiosk's display cube materials, structural dimensions, mesh sizes and quantity used are optional style elements and custom designed from a plurality of materials which are best adaptable according to the products to be sold and requirements at the display merchandising location. For example, if food products are being sold in a food cafeteria environment, stainless steel may be the required cube material, or if plush toy animals are sold in a hospital gift shop, open rigid painted wire cage material may be preferred, or men's shirts in an airport display may best be sold in either clear acrylic, or glass cubes.

[0028] The construction specifications, securing methods, bottom weighting and support framing, if necessary may vary depending on several conditions, such as but not limited to; the kiosk material style used, size of the structure and structure's location and other requirements, which may also be subject to applicable local codes.

[0029] The kiosk structure may be constructed as either a one piece unit and delivered intact, or prefabricated with the cubicles, structural elements and electronic components parts securely assembled at the install location.

[0030] The width, height and depth of the kiosk structure is optional, depending on the products to be sold, electronic component's needs and install location space requirements. The display cubes sizes do not all need to be equal, as long as the structure's overall perimeter forms a rectangle. For the purpose of this application's illustration's size example, the invention structure is a 21 cube style kiosk with 15" square cubes stacked 4 cubes wide by 5 cubes high, plus a 8" high top compartment and 3" bottom compartment, plus 1" skeletal frame which is then a 62" wide×88" high×26" deep cube kiosk.

[0031] Referring now to the invention in further detail, depending on the kiosk style, the kiosk's structural skeletal frame, FIGS. 1 thru 10, element 26, may be made of a plurality of structural sizes and materials, such as, but not limited to: aluminum, rigid plastic, composite, wood, steel, or other metal and the like, either painted, or not and fabricated in either tubular, solid, or modular design types. The kiosk's skeletal frame secures the cubes and structurally supports the kiosk's electronic and mechanical components. For purpose of this application's illustration, the structural skeletal frame in FIGS. 1 thru 10, element 26 is a 1" square, hollow aluminum extrusion material.

[0032] In more detail, connecting cables and wires either travel through a hollow structural frame, or in an inconspicuous conduit attached to the frame and according to code requirements, if necessary.

[0033] In more detail, still referring to the structural skeletal frame, FIGS. 1 thru 10, element 26, when the frame is made with aluminum, or other metals and the kiosk style has a full closure security curtain, FIGS. 3, 6 and 9, element 25, the structural frame extrusion has a custom design at the kiosk's front side opening, FIG. 9, drawing insert element 26.2. The custom frame extrusion opening provides a built-in channel to secure the curtain sides and serves as side guides for the curtain to travel in.

[0034] Referring now to the invention's in further detail, there is shown a full closure curtain FIGS. 3, 6 and 9, element 25, which secures the display merchandise cubicles and kiosk's electronics components in cube type E after business

hours. The curtain may be opened and closed, either manually, or mechanically via a tubular motor, FIGS. 1 thru 9, element 24. Alternatively, if the kiosk is located in a room which is locked after business hours, or additional security is not necessary, the full closure curtain and tubular motor may be omitted.

[0035] Referring now to the invention in further detail in FIGS. 1, 2 and 6 thru 8, cube type E, there is shown in the center of the kiosk an electronics components compartment. The electronics components compartment's location in the kiosk unit is optional and may alternatively be in another conveniently accessible cube location. Additionally, the bottom, sides, back and top of cube type E is made of a plurality of solid opaque materials, such as mentioned for the top compartment below [0029].

[0036] In further detail, still referring to the electronics compartment cube type E, contained within it is a computer assembly, FIGS. 6 and 9, element 10, a barcode scanner, FIGS. 1, 2, 6 and 9, element 13, a touch screen monitor, FIGS. 1, 2, 6 and 9, element 11 and transaction facilitator assembly with various electronic components and peripheral devices, FIGS. 1, 2, 6 and 9, elements 12 thru 18. The electronic components in cube type E provide the kiosk purchase transaction functions, internet connections, audio and video communications, security devices and consist of; but are not limited to the following described components. More specifically, seen from the kiosk's front view is:

[0037] a. A touch screen monitor, FIGS. 1, 2, 6 and 9, element 11, which can be in a plurality of screen sizes according to the kiosk style. The monitor's screen displays images, product descriptions, graphics and price information of the same merchandise which is also being displayed in the kiosk's selection cubes and guides a user to a purchase transaction.

[0038] In more detail, the monitor's screen, FIGS. 1, 2, 6 and 9, element 11 first displays individual touch screen product photo buttons which offer a merchandise selection, along with an initial screen messages, such as; "Select an item and scan it's barcode, or touch its photo here".

[0039] In more detail, when a product selection is made, either via a barcode scan, or the touch screen, another touch screen button then facilitates a point-of-sale purchase transaction using a credit, or debit card reader swipe, FIGS. 1, 2, 6 and 9, element 12. Or alternatively, another touch screen button provides information for a cash, or check sale using either the cash acceptor, FIGS. 1, 2, 6 and 9, element 14, or check and cash transactions mail-in envelope methods, FIGS. 1, 2, 6 and 9, element 14.2.

[0040] In more detail, another touch screen button also provides a screen display for general product purchase, return and warranty information and another touch screen button activates VoIP phone assistance to a remote manager, if necessary. When the VoIP phone is activated, the monitor screen displays a picture in picture, two-way video image, via the kiosk's webcam, FIGS. 1 thru 9, element 19.

[0041] In more detail, while the kiosk is awaiting customer interaction, the monitor screen saver can also display digital promotional images to attract customers to the kiosk, or messages to initiate a merchandise selection.

[0042] b. A credit and debit card magnetic swipe reader, FIGS. 1, 2, 6 and 9, element 12 processes non-cash sale transaction payments. The card swipe reader facilitates a

purchase transaction payment in tandem with the computer assembly, its custom software and the internet modem components.

[0043] c. A barcode scanner, FIGS. 1, 2, 6 and 9, element 13 can read a customer's hand selected merchandise's barcode tag and then interpret the purchase information to the respective item's photo display on the touch screen monitor, which then guides a customer to make a purchase transaction.

[0044] d. A cash payment bill acceptor, FIGS. 1, 2, 6 and 9, element 14 accept bills and processes cash sale transaction payments.

[0045] In more detail, an alternative cash payment sale method in a trusted sales environment, or donation situation, is a mail-in envelopes holder/drop box facilitator FIGS. 1, 2, 6 and 9, element 14.2 which is provided at the same kiosk cube E location for cash, or check payments in lieu of the bill acceptor. Or, if the sales location, merchandise to be sold, or kiosk style does not require cash sale transactions, the cash payment methods may be omitted and only credit and debit cards accepted.

[0046] e. Receipt printer, FIGS. 1, 2, 6 and 9, element 15 delivers a sale receipt after each transaction.

[0047] In further detail, still referring to cube E, located behind the monitor and transaction facilitator assembly and not seen from the front view are other integrated electronic components which are shown in FIGS. 6 and 9, cut-a-way views, elements 10, and 16 thru 18 such as, but not limited to:

[0048] f. Dual processor computer assembly in FIGS. 6 and 9, element 10 which can be configured in a plurality of operating capacity and software functions according to the kiosk style requirements. The computer assembly facilitates the kiosk's electronic operations and purchase transaction components with inputs from the touch screen monitor, FIGS. 1, 2, 6 and 9, element 11 and activates the appropriate kiosk hardware, relays, switches, devices, and the like via the kiosk's computer's special software programming.

[0049] In more detail, the computer assembly functions also maintains the kiosk merchandise inventory records, each sale transactions' financial data and the computer systems programming and maintenance which can all be accessed and managed by either a remote, or on-site kiosk manager.

[0050] g. Miscellaneous electronic components and various ancillary computer hardware devices, FIGS. 6 and 9, element 16 serve the kiosk and its computer assembly, such as but not limited to: relays, wiring, battery back-up, power surge suppressor, other accessory devices, and the like.

[0051] h. Wireless internet modem and router device, FIGS. 6 and 9, element 17 connects to the Internet, via cellular technology and serves the kiosk computer assembly and its related electronic components in various ways, such as but not limited to: (1). Processes credit and debit card purchase transactions, (2). Facilitates webcam functions, and (3). Transmits the kiosk operations information to a remote manager for security, marketing conditions, programming and maintenance service needs.

[0052] i. Audio components, FIGS. 6 and 9, element 18 serve the kiosk functions in various ways, such as but not limited to: (1). Create unique marketing sounds and/or music in the proximity area of the kiosk which attract customers to notice the displayed merchandise, (2). Provide audio communications between a customer and a remote kiosk manager, and (3). Serve as an element of the kiosk's security system components.

[0053] Referring now to the top of the kiosk invention is a webcam video device, FIGS. 1 thru 9, element 19 which is located slightly above and protruding out from the top, compartment front, FIGS. 1 thru 9, element 20. The webcam can rotate and serves the kiosk functions in several ways, such as but not limited to: (1). Observes potential customer traffic for a remote manager to activate the kiosk's customer attracting audio devices, (2). Facilitates VoIP and video communications between a customer and a remote kiosk manager, if necessary, and (3). Serves as an element of the kiosk's security system components.

[0054] Referring now again to the top of the kiosk invention is a top compartment FIGS. 1 thru 8, element 20 which is formed by the kiosk structural skeletal frame, FIGS. 1 thru 10, element 26 design. The top compartment has a full covering on all sides made from a plurality of solid opaque materials, such as but not limited to: aluminum, acrylic, plastic, composite, wood, other metals and the like depending on the kiosk style.

[0055] In more detail, the kiosk's top compartment, FIGS. 1 thru 8, element 20 stores and covers the kiosk's full closure security curtain assembly, FIGS. 3 and 6, element 25, along with the optional tubular motor components, FIGS. 1 thru 9, element 24 and other peripheral devices, if applicable.

[0056] In more detail, the kiosk's top compartment's, FIGS. 1 thru 8, element 20 also provides an alternate location for electronic components and devices which are not required to be located in cube E. The top covering height is optional depending on the kiosk style and it can be raised reasonably higher, if needed and the install location permits.

[0057] In more detail, the top compartment exterior, FIGS. 1 thru 9, element 20 also serves to display signage at the kiosk top.

[0058] Referring now to the invention, located at the bottom of the kiosk is a compartment, FIGS. 1 thru 8, element 23, which is formed by the kiosk structural skeletal frame, FIGS. 1 thru 10, element 26. The bottom compartment has a full covering on all sides made from a plurality of solid opaque materials, such as but not limited to: aluminum, acrylic, plastic, composite, wood, other metals and the like depending on the kiosk style.

[0059] In more detail, the kiosk's bottom compartment stores and covers fastening devices and weighting materials used to secure and stabilize the kiosk structure, if necessary.

[0060] In further detail, referring to the tubular motor assembly, FIGS. 1 thru 9, element 24 which is located at the top of the kiosk and mostly unseen behind the top compartment covering, FIGS. 1 thru 9, element 20. Unless a manual operation is preferred, the optional tubular motor is used for opening and closing the full closure security curtain, FIGS. 3 and 6, element 25, which is then attached and wrapped around the motor mechanism.

[0061] In more detail, the tubular motor is controlled by a combination of electronic devices, such as but not limited to: relays, switches, timers and the like. The tubular motor can be activated either manually by a kiosk manager, or automatically by the kiosk's integrated computer, FIG. 3, element 10 assembly and its special computer software program, or a timer device.

[0062] In further detail, referring to the full closure security curtain, FIGS. 3 and 6, element 25, the covering can be made from a plurality of rollable materials depending on the kiosk's optional styles and the installation location's need, such as, but not limited to: aluminum, sturdy fabric, vinyl, graphite

fiber type, or other rollable materials, being either painted, or not and fabricated in a plurality of methods, such as but not limited to: horizontal slat, or link construction, woven, and the like. For the purpose of this application's illustration, a rollable aluminum metal slat full closure curtain, FIG. 3, element 25 covers over either the visually clear, or rigid wire mesh material style.

[0063] In more detail, when the kiosk display is open, the full closure curtain retracts into the top compartment covering, FIGS. 1 thru 9, element 20. The security closure curtain can be opened and closed via a tubular motor, or manually by the kiosk manager and without a tubular motor.

[0064] In more detail, when the kiosk full closure security curtain is closed, it can visually display advertisements, or other customer attracting graphics and information.

[0065] Referring now to the invention, located at the bottom of the kiosk is a compartment, FIGS. 1 thru 8, element 23, which is formed by the kiosk structural skeletal frame, FIGS. 1 thru 10, element 26. The bottom compartment has a full covering on all sides made from a plurality of solid opaque materials, such as but not limited to: aluminum, acrylic, plastic, composite, wood, other metals and the like depending on the kiosk style.

[0066] In more detail, the kiosk's bottom compartment stores and covers fastening devices and weighting materials used to secure and stabilize the kiosk structure, if necessary.

[0067] While the foregoing written description of the invention enables one of ordinary skill to make and use what is considered presently to be the best mode thereof, those of ordinary skill will understand and appreciate the existence of variations, combinations, and equivalents of the specific embodiment, method, and examples herein. The invention should therefore not be limited by the above described embodiment, method, and examples, but by all embodiments and methods within the scope and spirit of the invention.

[0068] All of the invention's materials and electronic technology components used and mentioned in the previous paragraphs are currently existing, easily obtainable consumer products, which in themselves may not be new, but when are combined and assembled as described herein, along with the invention's conceptual ideas make the CubeKiosk invention unique.

What is claimed is:

1. A self-service vending kiosk comprising:

- (a) a plurality of open cubicles, which store and display merchandise are custom sized and made with a plurality of materials to best suit products being sold and the kiosk location requirements; and
- (b) integrated within cubicles is a compartment with a touch screen product selector, barcode scanner, transaction facilitator, computer assembly components; and
- (c) utilizes a self-service selection and non-electro-mechanical product delivery method; and
- (d) sells products without a transaction employee, unless necessary, at which time a VoIP communication can be made to a remote manager; and
- (e) has audio devices and signage which can attract customers; and
- (f) incorporates a webcam which visually observe the kiosk environment for customer interaction, VoIP video and serves security functions; and
- (g) has a full closure curtain which secures the kiosk.

2. The vending kiosk as set forth in claim 1 wherein the structure's optional visually open construction materials can be customized according to the products being sold and sales location needs.

3. The vending kiosk as set forth in claim 1 wherein its individual display cubicles and the structure's overall size can be customized according to the products being sold and sales location needs.

4. The vending kiosk as set forth in claim 1 wherein the merchandise display vending display kiosk incorporates a touch screen selector, barcode scanner, transaction facilitator and computer assembly displayed as an integral element within the kiosk structure.

5. The vending kiosk as set forth in claim 1 wherein the vending kiosk's merchandise delivery method is via a hand selection, self-delivery means.

6. The vending kiosk as set forth in claim 1 wherein the kiosk invention's simpler form and functions eliminates other vending methods mechanical delivery devices.

7. The vending kiosk as set forth in claim 1 wherein the kiosk's webcam observes customer traffic, provides kiosk security and facilitates VoIP communications.

8. The vending kiosk as set forth in claim 1 wherein the kiosk's components provide audio and visual communications between a customer and a remote manager at the transaction event time.

9. The vending kiosk as set forth in claim 1 wherein audio features provide unique sounds which attract customer interest to said kiosk.

10. The vending kiosk as set forth in claim 1 wherein an open display, self-service merchandise purchase does not require a transaction person's assistance.

11. The vending kiosk as set forth in claim 1 wherein an open merchandise display is combined with self-service transaction vending components.

12. The vending kiosk as set forth in claim 1 wherein the kiosk displays and sells merchandise with a customers' self-service barcode scan.

13. The vending kiosk as set forth in claim 1 wherein a self-service merchandising kiosks can be easily customized and adapted to products being sold and install location needs.

14. The vending kiosk as set forth in claim 1 wherein the kiosk full closure curtain secures the display merchandise and electronic components, at the end of business day.

15. The vending kiosk as set forth in claim 1 wherein the kiosk structural channel has a special design which secures and provides a guide track for the closure curtain.

16. The vending kiosk as set forth in claim 1 wherein the kiosk electronic components and computer assembly are controlled remotely, via wireless methods by a remote manager

17. The vending kiosk as set forth in claim 1 wherein the kiosk has a tubular motor for opening and closing the security curtain component.

18. The vending kiosk as set forth in claim 1, wherein the merchandise vending kiosk can be placed in either semi-attended, or self service retail environments, such as but not limited to; shopping malls hospitals, convenience stores, airports, and the like.

* * * * *