



US011312519B2

(12) **United States Patent**
Huber et al.

(10) **Patent No.:** **US 11,312,519 B2**

(45) **Date of Patent:** **Apr. 26, 2022**

(54) **STRAPPING APPARATUS**

(71) Applicant: **Signode Industrial Group LLC**,
Glenview, IL (US)

(72) Inventors: **Hans Huber**, Hagglingen (CH);
Dimitrios Takidis, Dubendorf (CH);
Michael Meng, Gipf-Oberfrick (CH);
Roland Widmer, Haar (DE); **Christian Benz**, Zurich (CH)

(73) Assignee: **Signode Industrial Group LLC**,
Tampa, FL (US)

(*) Notice: Subject to any disclaimer, the term of this patent is extended or adjusted under 35 U.S.C. 154(b) by 104 days.

(21) Appl. No.: **15/931,698**

(22) Filed: **May 14, 2020**

(65) **Prior Publication Data**

US 2020/0270007 A1 Aug. 27, 2020

Related U.S. Application Data

(63) Continuation of application No. 15/117,403, filed as application No. PCT/CH2015/000015 on Feb. 10, 2015, now Pat. No. 10,689,140.

(30) **Foreign Application Priority Data**

Feb. 10, 2014	(CH)	181/14
Feb. 10, 2014	(CH)	182/14
Feb. 10, 2014	(CH)	183/14

(51) **Int. Cl.**

B65B 13/22 (2006.01)
B65B 13/06 (2006.01)

(Continued)

(52) **U.S. Cl.**

CPC **B65B 13/22** (2013.01); **B65B 13/06** (2013.01); **G06F 40/186** (2020.01); **G06K 9/222** (2013.01);

(Continued)

(58) **Field of Classification Search**

CPC B65B 13/06; B65B 13/18; B65B 13/22;
B65B 13/24; B65B 13/30; B65B 13/32;
(Continued)

(56) **References Cited**

U.S. PATENT DOCUMENTS

2,194,108 A 3/1940 Parvin
2,707,429 A 5/1955 Leslie, II et al.
(Continued)

FOREIGN PATENT DOCUMENTS

CA 2432353 A1 12/2003
CH 705745 A2 5/2013
(Continued)

OTHER PUBLICATIONS

"Final Office Action", From U.S. Appl. No. 15/117,410 (20 pages), dated Aug. 20, 2019.

(Continued)

Primary Examiner — Jimmy T Nguyen

(74) *Attorney, Agent, or Firm* — Neal, Gerber & Eisenberg LLP

(57) **ABSTRACT**

The present disclosure relates to a strapping head of a strapping device for strapping packaged goods with a strap. The strapping head includes an advancing apparatus and tensioning apparatus having at most three rollers for transferring an advancing motion, a retracting motion, and a tensioning motion to the strap. A least one of the wheels is operatively connected to a driving apparatus to cause the at least one of the wheels to rotate about a rotational axis for the advancing, retracting, and tensioning motions. The rollers can be brought in contact with the strap in pairs on both sides of the strap in different combinations with each other.

17 Claims, 12 Drawing Sheets

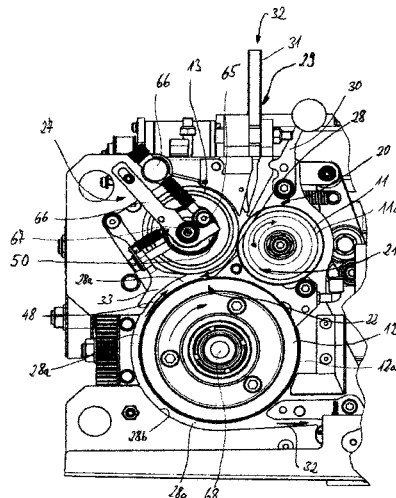

(56)

References Cited

U.S. PATENT DOCUMENTS

2011/0056392 A1 3/2011 Neeser et al.
 2011/0100233 A1 5/2011 Neeser et al.
 2011/0146505 A1 6/2011 Schwede
 2011/0253480 A1 10/2011 Goodman et al.
 2012/0017780 A1 1/2012 Haberstroh et al.
 2012/0160364 A1 6/2012 Katou et al.
 2012/0210682 A1 8/2012 Gardner et al.
 2012/0216688 A1 8/2012 Liu et al.
 2013/0014653 A1 1/2013 Lai
 2013/0014654 A1 1/2013 Lai
 2013/0098252 A1 4/2013 Haberstroh et al.
 2013/0276415 A1 10/2013 Haberstroh et al.
 2014/0083310 A1 3/2014 Hoehn et al.
 2016/0107775 A1 4/2016 Amacker et al.
 2016/0137323 A1 5/2016 Amacker
 2016/0159505 A1 6/2016 Widmer et al.
 2019/0046819 A2 2/2019 Huber et al.

FOREIGN PATENT DOCUMENTS

CN 1151129 A 6/1997
 CN 2266566 Y 11/1997
 CN 1203878 A 1/1999
 CN 1253099 A 5/2000
 CN 2486463 Y 4/2002
 CN 1418163 A 5/2003
 CN 1558842 A 12/2004
 CN 1660675 A 8/2005
 CN 1859999 A 11/2006
 CN 101134308 A 3/2008
 CN 101164416 A 4/2008
 CN 101287578 A 10/2008
 CN 101486329 A 7/2009
 CN 101585244 A 11/2009
 CN 201411061 Y 2/2010
 CN 101678903 A 3/2010
 CN 101870367 A 10/2010
 CN 102026873 A 4/2011
 CN 102026874 A 4/2011
 CN 102026875 A 4/2011
 CN 202100012 U 1/2012
 DE 2818325 A1 11/1979
 DE 3916355 A1 12/1989
 DE 4014305 A1 11/1991
 DE 19751861 A1 1/1999
 DE 10026200 A1 11/2001
 DE 20321137 U1 1/2006
 DE 102005049130 A1 4/2007
 DE 102006007990 A1 8/2007
 DE 102009047443 A1 6/2011
 DE 202011050797 U1 11/2011
 EP 0095643 A2 12/1983
 EP 0337781 A1 10/1989
 EP 0337782 A1 10/1989
 EP 0480627 A1 4/1992
 EP 0603868 A1 6/1994
 EP 0659525 A2 6/1995
 EP 0744343 A1 11/1996
 EP 0949146 A1 10/1999
 EP 0997377 A1 5/2000
 EP 0999133 A1 5/2000
 EP 1177978 A1 2/2002
 EP 1316506 A1 6/2003
 EP 1357033 A2 10/2003
 EP 1413519 A1 4/2004
 EP 2271553 B1 4/2013
 GB 1161827 A 8/1969
 GB 2041869 A 9/1980
 GB 2481724 A 1/2012
 JP S5290398 U 7/1977
 JP S541238 B1 1/1979
 JP S5638220 A 4/1981
 JP 57-023611 B 5/1982
 JP S6322320 A 1/1988
 JP H05198241 A 8/1993

JP H07300108 A 11/1995
 JP H08258808 A 10/1996
 JP H08324506 A 12/1996
 JP H09283103 A 10/1997
 JP 3044132 B2 5/2000
 JP 2000128113 A 5/2000
 JP 2000128115 A 5/2000
 JP 3227693 B2 9/2001
 JP 3242081 B2 10/2001
 JP 2002235830 A 8/2002
 JP 2003170906 A 6/2003
 JP 2003231291 A 8/2003
 JP 2003348899 A 12/2003
 JP 3548622 B2 4/2004
 JP 2004108593 A 4/2004
 JP 2004241150 A 8/2004
 JP 2004323111 A 11/2004
 JP 2007276042 A 10/2007
 JP 4406016 B2 11/2009
 KR 840002211 B1 12/1984
 KR 20000029337 A 5/2000
 RU 1772784 C 10/1992
 RU 2118277 C1 8/1998
 RU 2161773 C2 1/2001
 RU 2004115639 A 1/2006
 RU 2355281 C2 5/2009
 RU 2355821 C1 5/2009
 SU 1134117 A3 1/1985
 WO 9627526 A1 9/1996
 WO 0138175 A1 5/2001
 WO 0189929 A1 11/2001
 WO 2006048738 A1 5/2006
 WO 2007116914 A1 10/2007
 WO 2009129633 A1 10/2009
 WO 2009129636 A1 10/2009
 WO 2009129637 A1 10/2009

OTHER PUBLICATIONS

“International Search Report and Written Opinion”, From PCT/CH2015/000015 (21 pages), dated May 15, 2015.
 “International Search Report and Written Opinion”, From PCT/CH2015/000013 (10 pages), dated May 18, 2015.
 “International Search Report and Written Opinion”, From PCT/CH2015/000014 (12 pages), dated May 18, 2015.
 “International Search Report and Written Opinion”, From PCT/CH2015/000016 (20 pages), dated May 18, 2015.
 “Non-Final Office Action”, From U.S. Appl. No. 15/117,416 (14 pages), dated Oct. 5, 2018.
 “Non-Final Office Action”, From U.S. Appl. No. 15/117,396 (23 pages), dated Feb. 7, 2019.
 “Non-Final Office Action”, From U.S. Appl. No. 15/117,410 (20 pages), dated Feb. 7, 2019.
 Bender, “Lithium Ion Technology: Shaping Power Tool”, Air Conditioning, Heating, and Refrigeration News, vol. 228, Issue 14, p. 18 (3 pages), Jul. 31, 2006.
 Emandi, Ali, “Brushless DC Motor Drives”, Energy-Efficient Electrical Motors, 3rd ed., Para. 270-272, CRC Press & Marcel Dekker (3 pages).
 Orgapack GmbH, “OR-T 100, Battery-Hand Tool For Plastic Strapping”, Operating and Safety Instructions (53 pages), Nov. 1, 2004.
 Orgapack GmbH, “OR-T 120, Battery-Operated Hand Tool for Plastic Strapping”, Operating Instructions (36 pages), Sep. 1, 2012.
 Orgapack GmbH, “OR-T 200, Battery-Hand Tool for Plastic Strapping”, Operating and Safety Instructions (53 pages), Feb. 1, 2004.
 Orgapack GmbH, “OR-T 250, Battery-Hand Tool for Plastic Strapping”, Operating Instructions (36 pages), Sep. 1, 2009.
 Orgapack GmbH, “OR-T 300, Battery-Hand Tool for Plastic Strapping”, Operating and Safety Instructions (53 pages), Mar. 1, 2005.
 Orgapack GmbH, “OR-T 400, Battery-Hand Tool for Plastic Strapping”, Operating Instructions (19 pages), Sep. 1, 2009.
 Orgapack GmbH, “OR-T 50, Hand Tool for Plastic Strapping”, Operating and Safety Instructions (53 pages), May 1, 2006.
 Orgapack GmbH, “OR-T 83, Hand Tool for Plastic Strapping”, Operating Instructions (58 pages), Aug. 1, 2000.

(56)

References Cited

OTHER PUBLICATIONS

Orgapack GmbH, "OR-T 85, Hand Tool for Plastic Strapping", Operating Instructions (58 pages), Jun. 1, 2000.

Orgapack GmbH, "OR-T 86, Hand Tool for Plastic Strapping", Operating Instructions (58 pages), Aug. 1, 1999.

Orgapack GmbH, "OR-T 87, Hand Tool for Plastic Strapping", Operating and Safety Instructions (63 pages), May 1, 2002.

"EP 3105128 Opposition Combined Exhibits E5a-E5e", (E5a) order of the strapping machine PM1810002 with the strapping head MH600 for the prior use V3; (E5b) Order; (E5c) Delivery note; (E5d) Invoice of forwarding company; (E5e) Invoice for prior use; Jan. 28, 2022.

"EP 3105128 Opposition Combined Exhibit E6 and E6a", (E6) Extracts of the instruction manual of the strapping machine PM1810002 and (E6a) instruction manual of the strapping head MH600.002.05; Jan. 28, 2022.

"EP 3105128 Opposition Exhibit E12", spare parts catalogue TR200 from OMS dated May 30, 2006; Jan. 28, 2022.

"EP 3105128 Opposition Exhibit E12a", extract from the Internet Archive Wayback Machine dated Nov. 28, 2013; Jan. 28, 2022.

"EP 3105128 Opposition Exhibit E15", operating and maintenance instructions Titan VK 100030-2 of Mar. 2, 1998; Jan. 28, 2022.

"EP 3105128 Opposition Exhibit E2", extracts of the instruction manual of the strapping machine PM150022; Jan. 28, 2022.

"EP 3105128 Opposition Exhibit E2a", instruction manual of the strapping head MH600.001.05; Jan. 28, 2022.

"EP 3105128 Opposition Exhibit E3", protocol for commissioning, technical acceptance and instruction for prior use V1; Jan. 28, 2022.

"EP 3105128 Opposition Exhibit E4a", extract from the Internet Archive Wayback Machine dated Feb. 4, 2012; Jan. 28, 2022.

"EP 3105128 Opposition Exhibit E4b", extract from the Internet Archive Wayback Machine dated Aug. 10, 2013; Jan. 28, 2022.

"Notice of Opposition", corresponding European Patent No. EP 3 105 128; dated Jan. 28, 2022.

"Notice of Opposition (English translation)", corresponding to European Patent No. 3 105 128; dated Jan. 28, 2022.

* cited by examiner

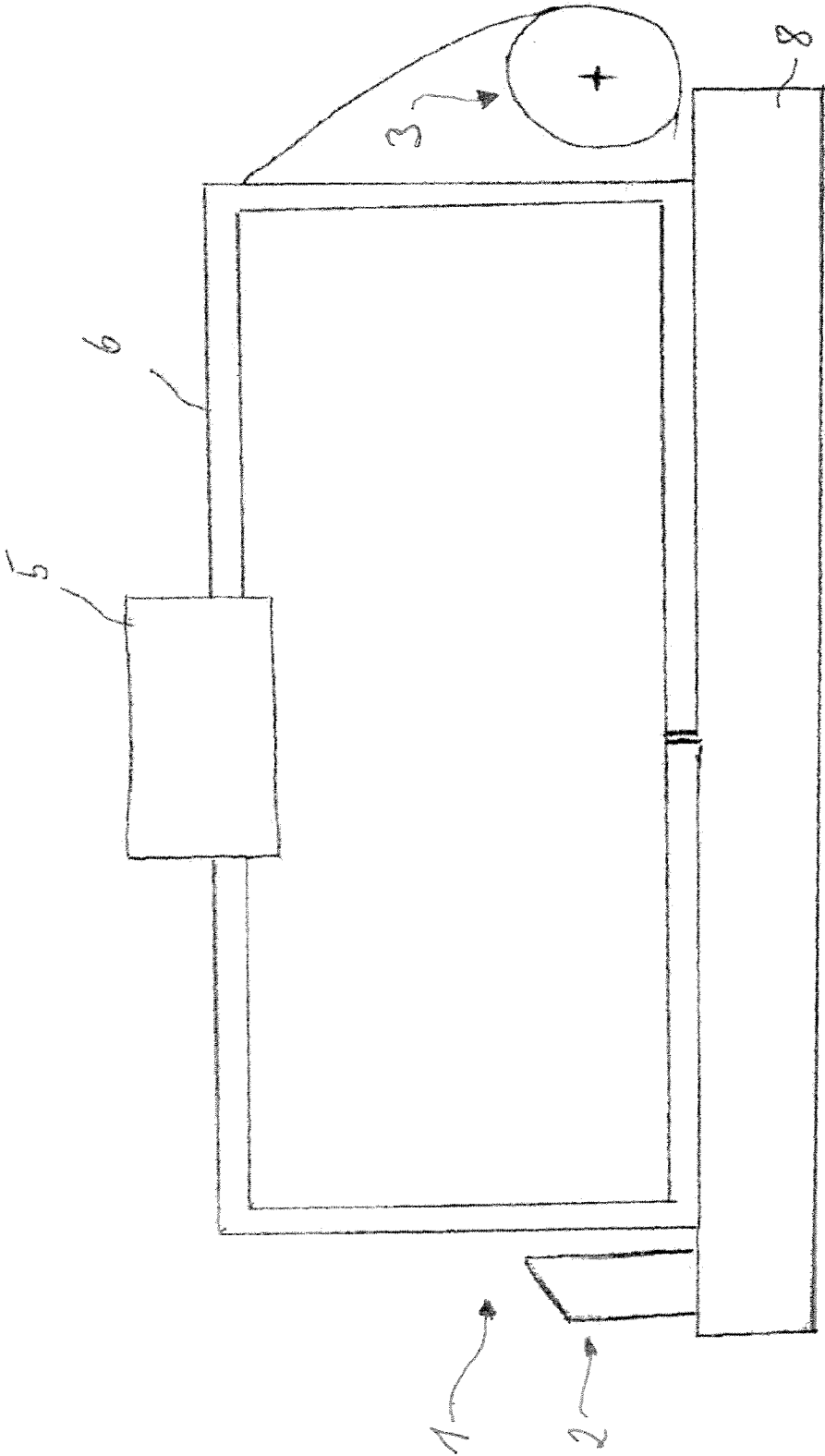
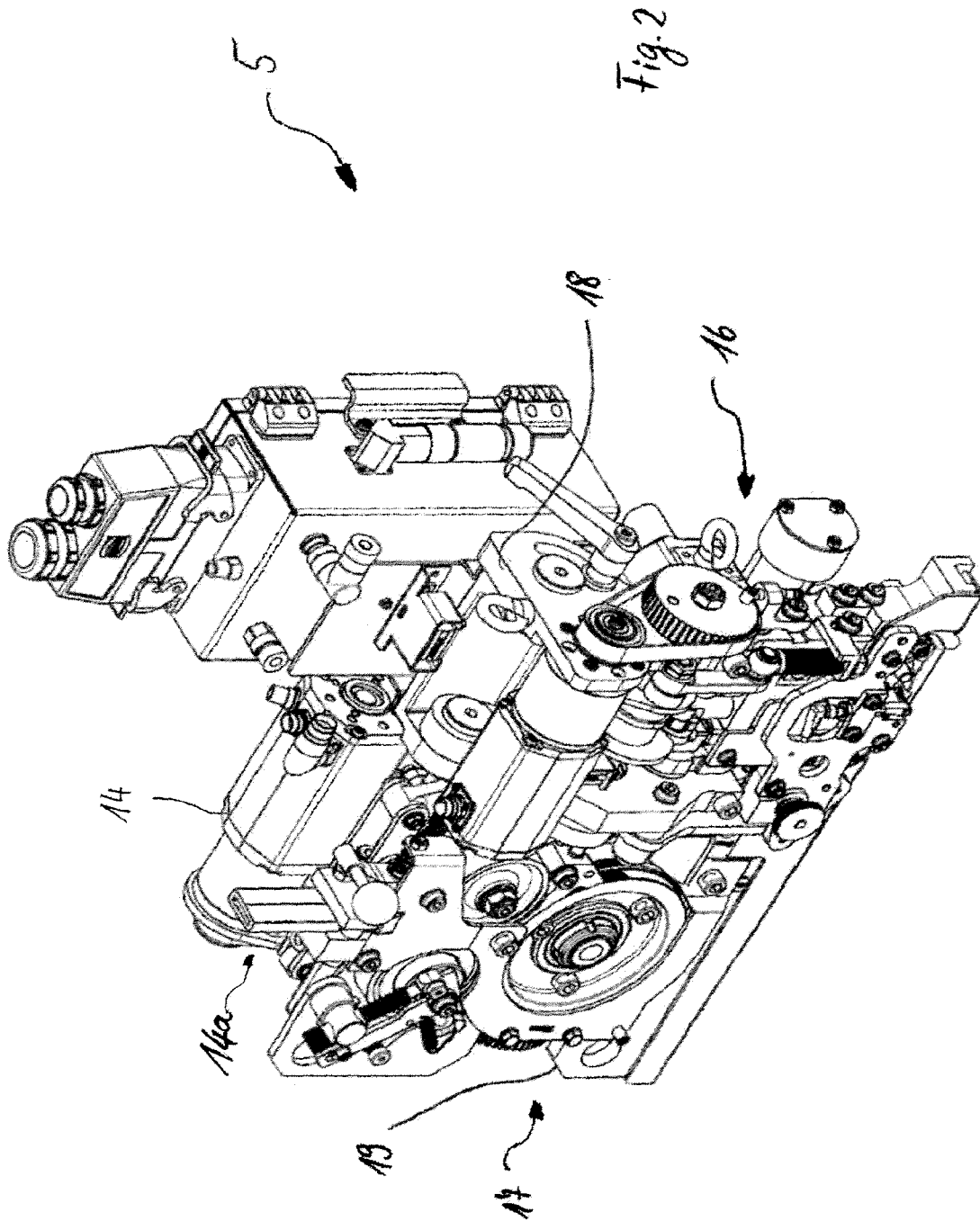
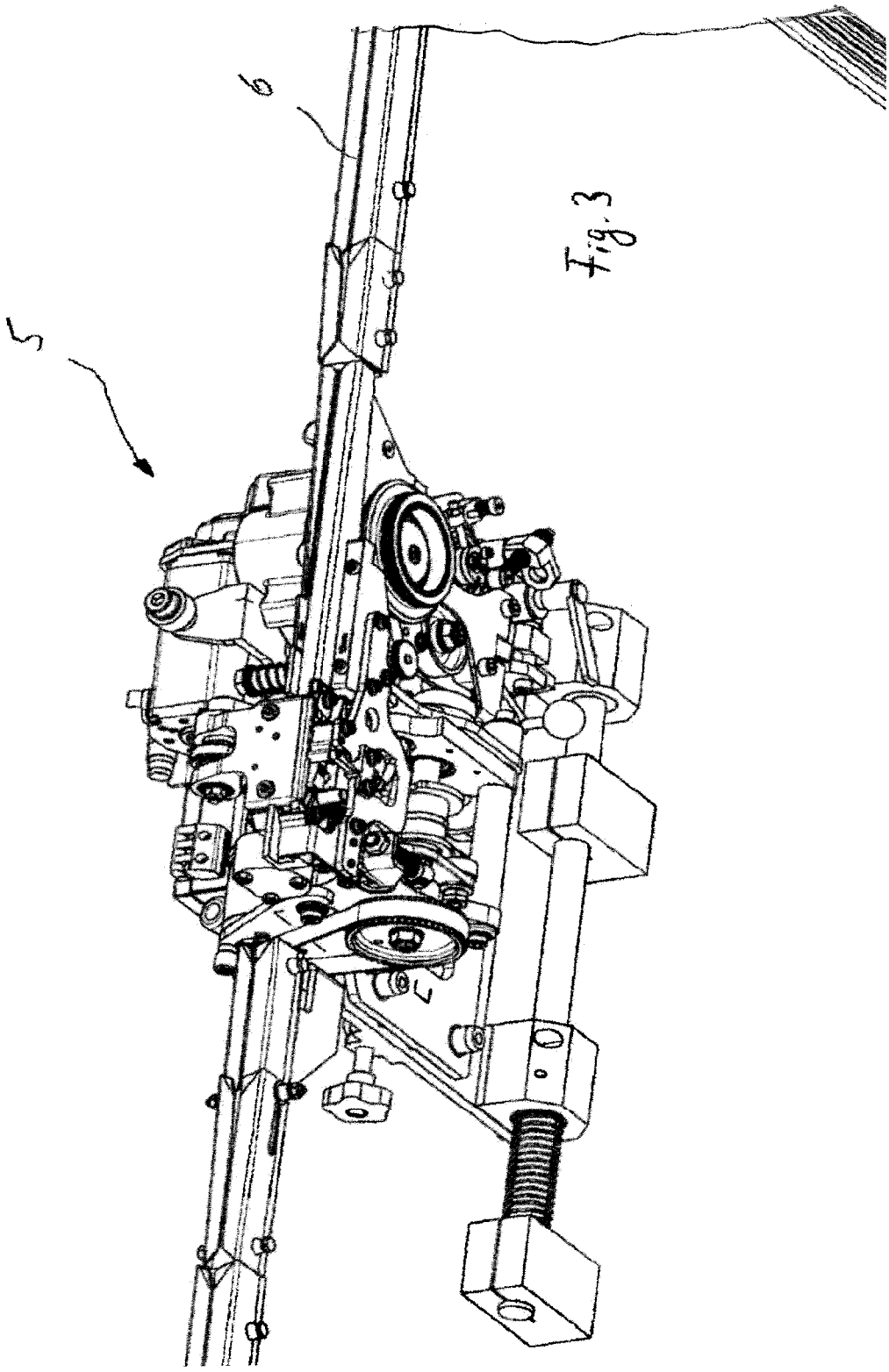

Fig. 1





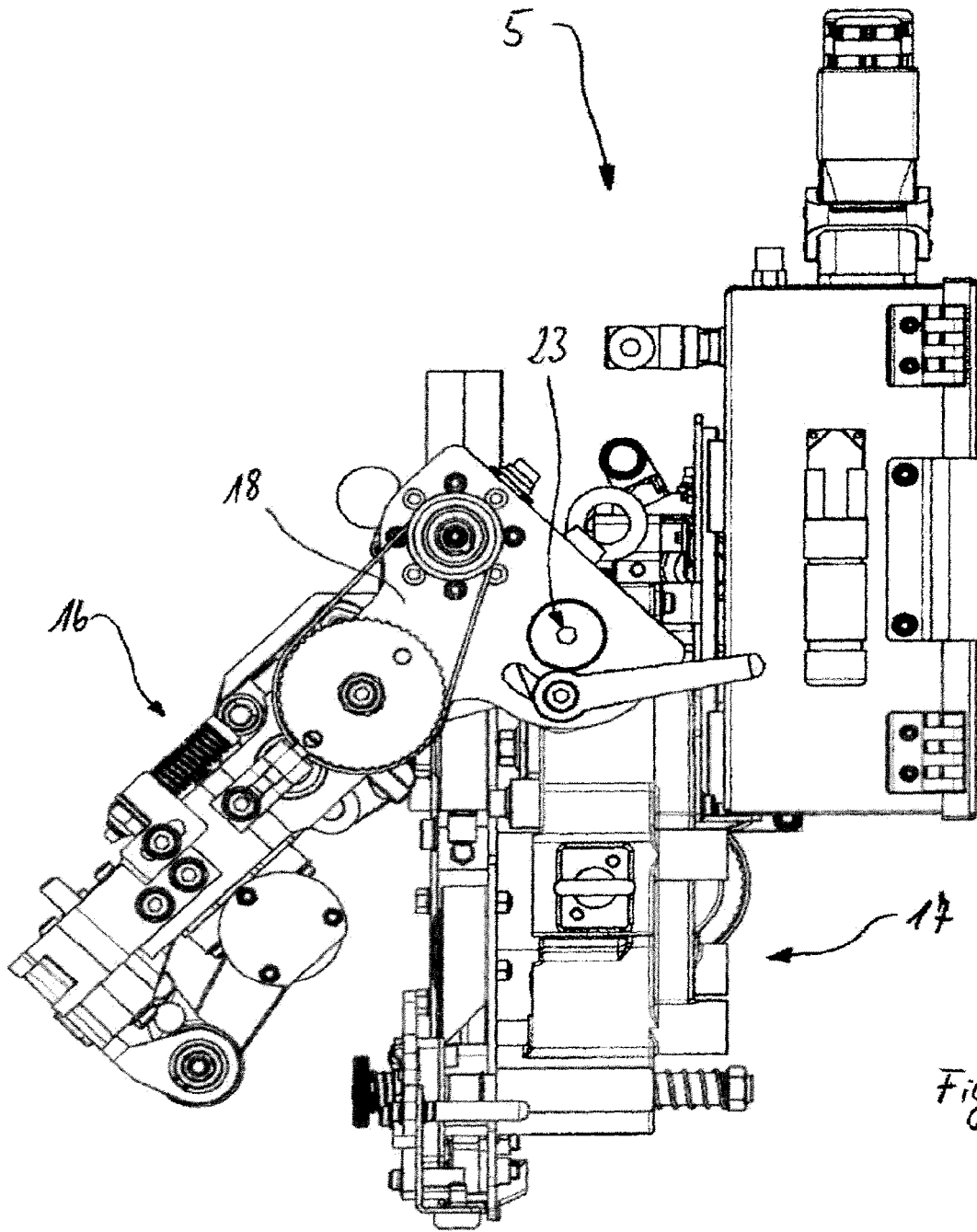
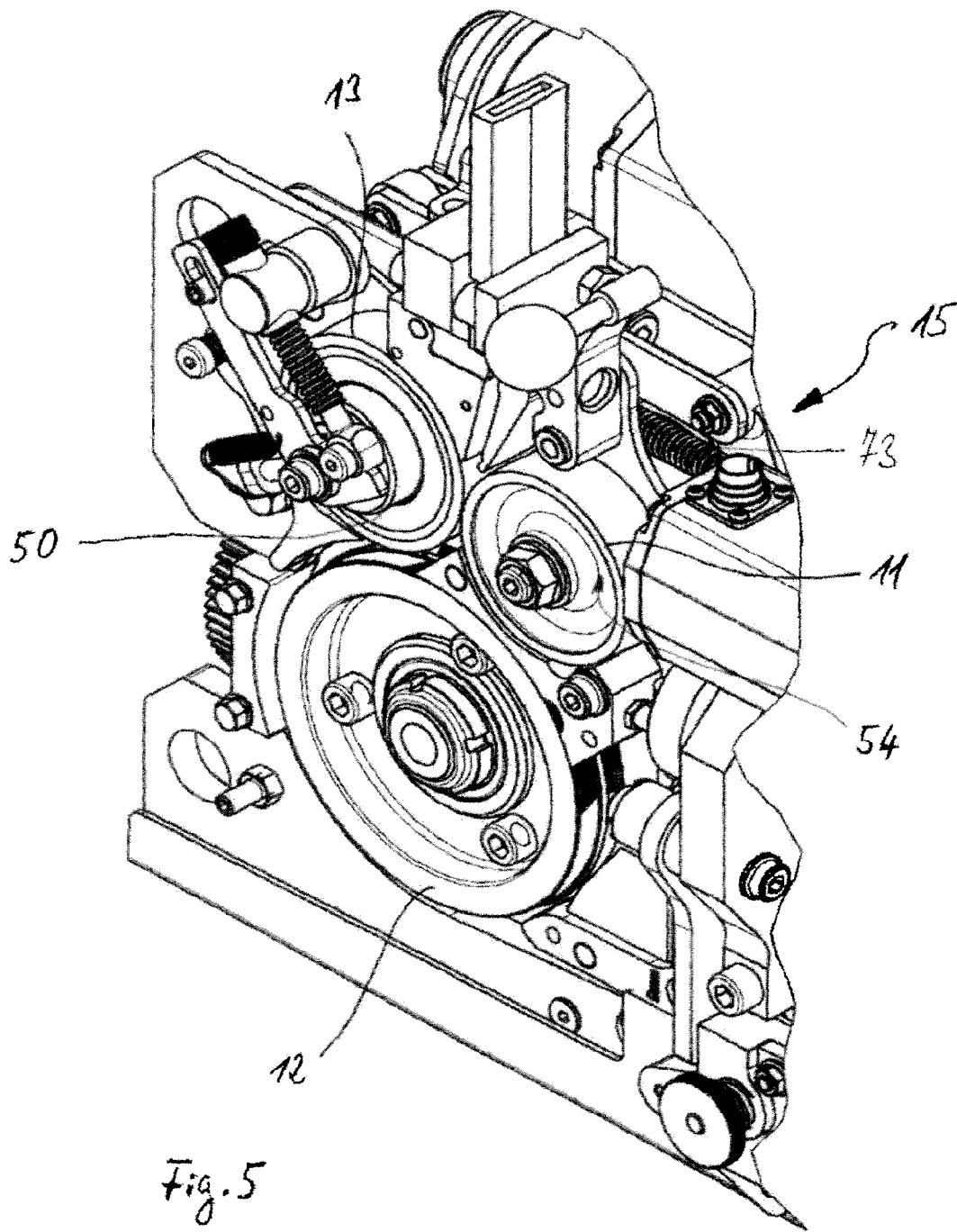
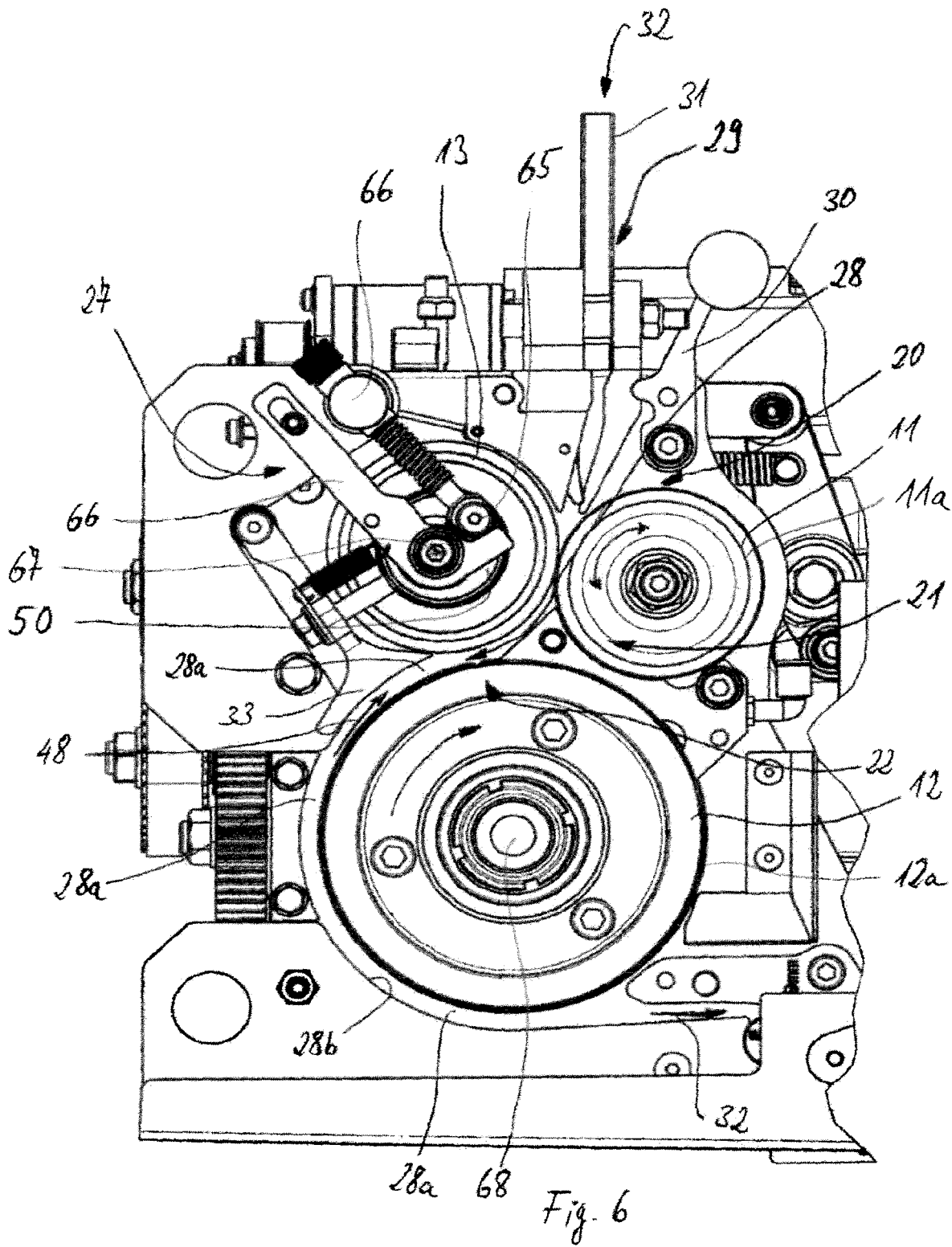
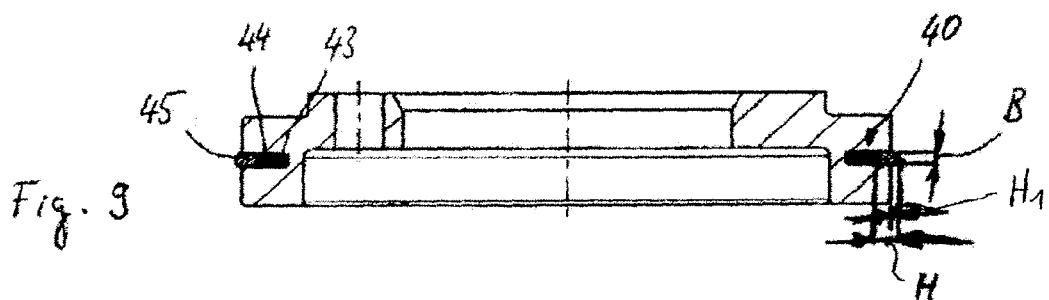
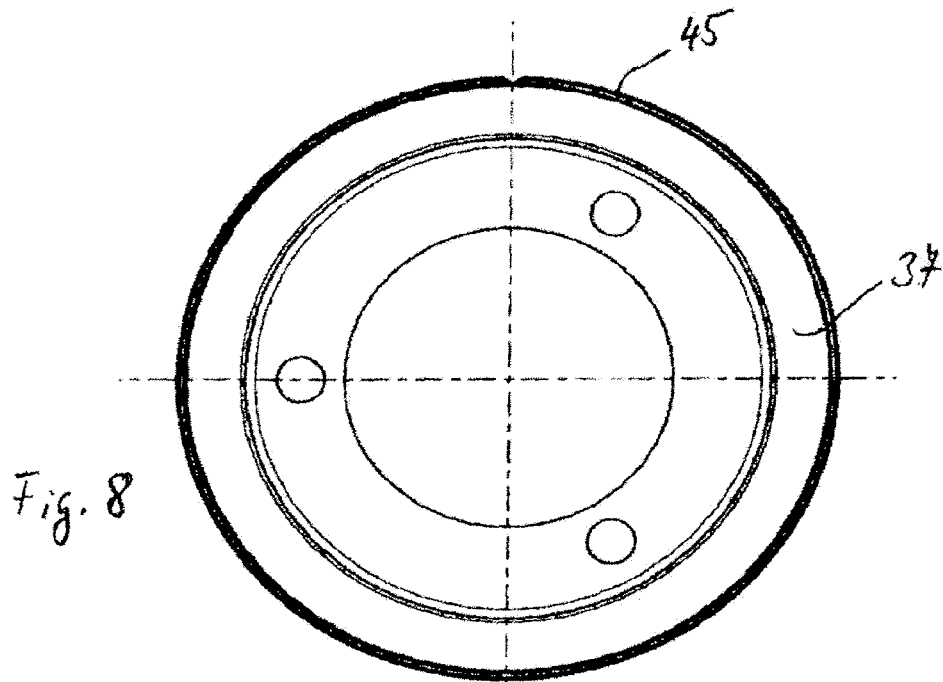
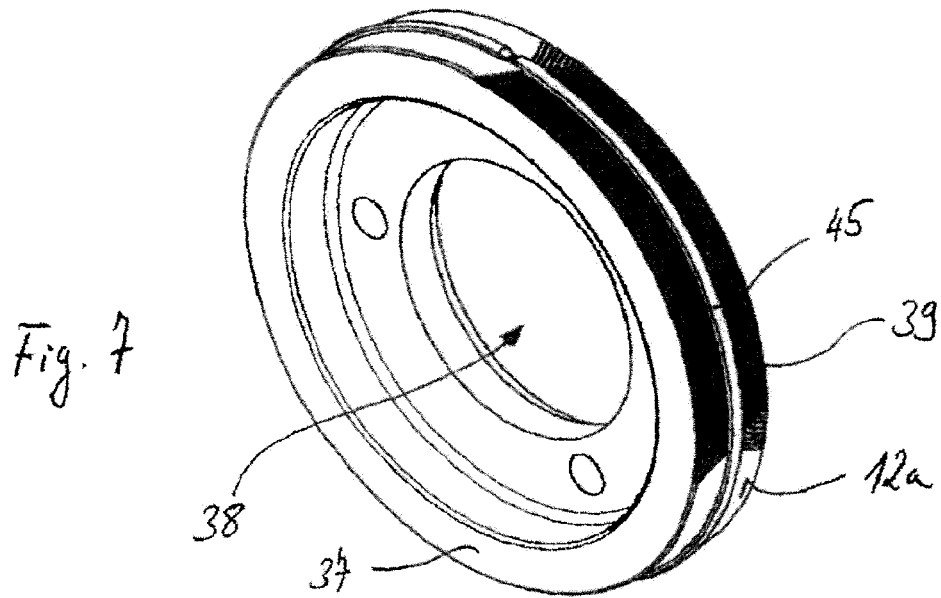
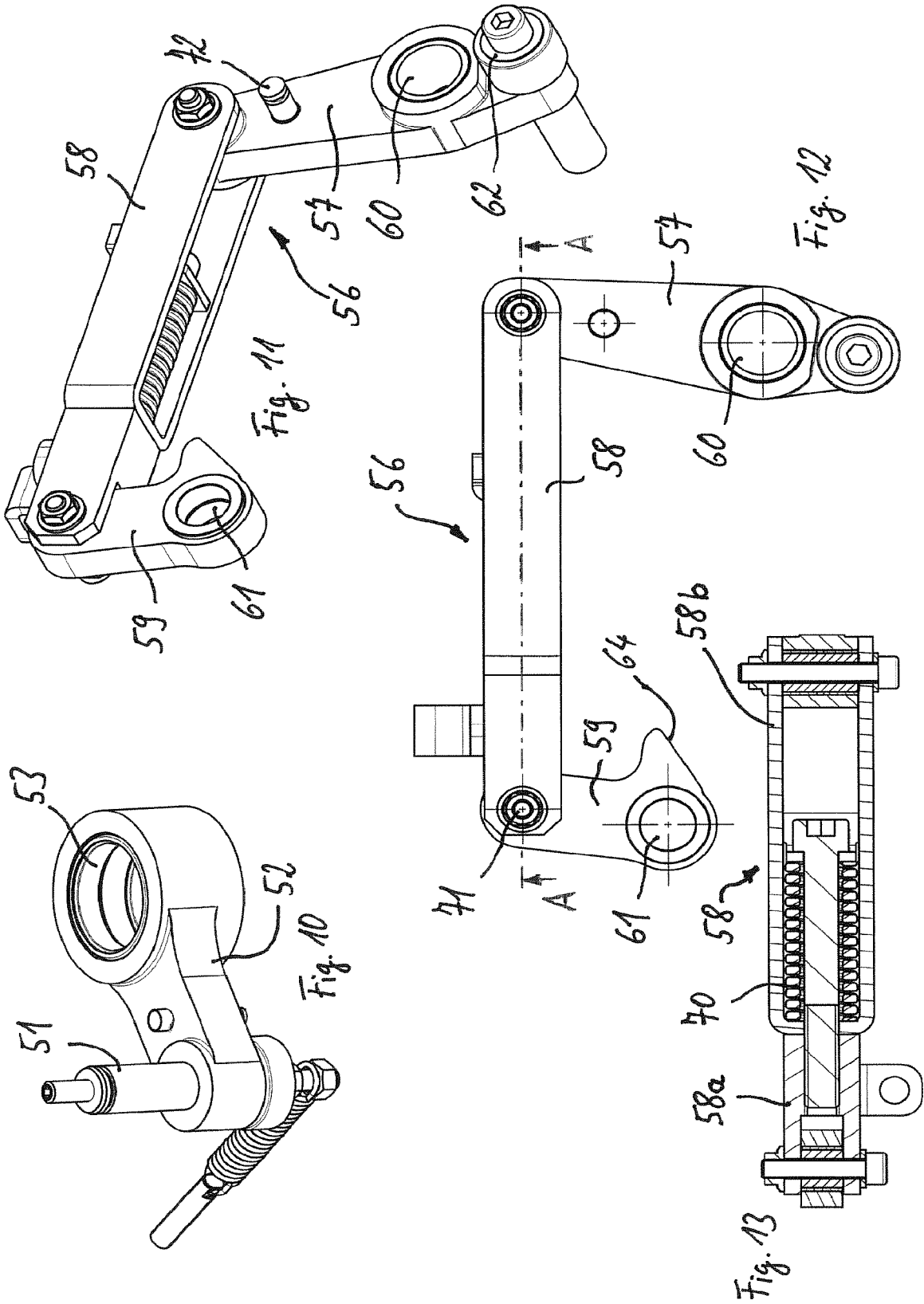

Fig. 4









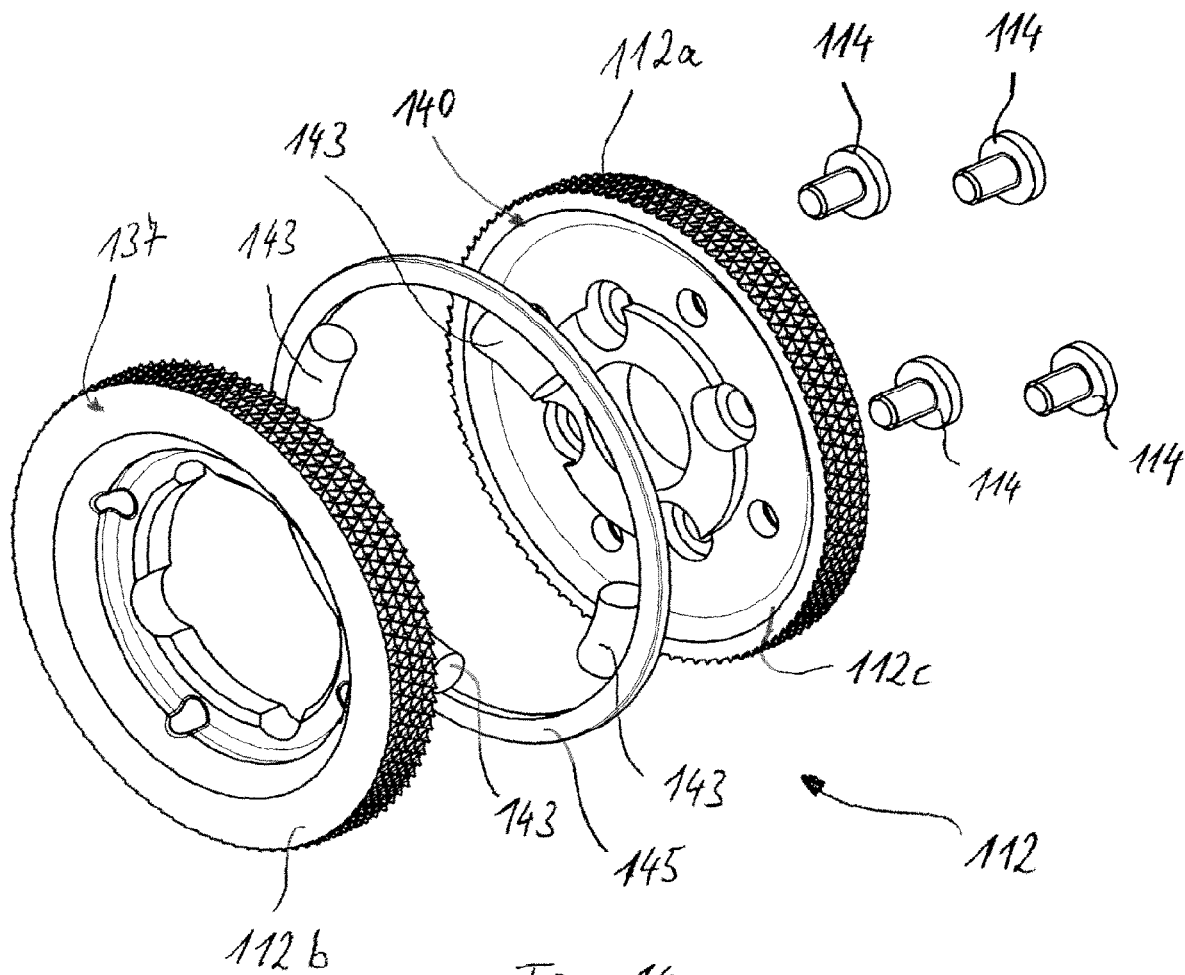

Fig. 14

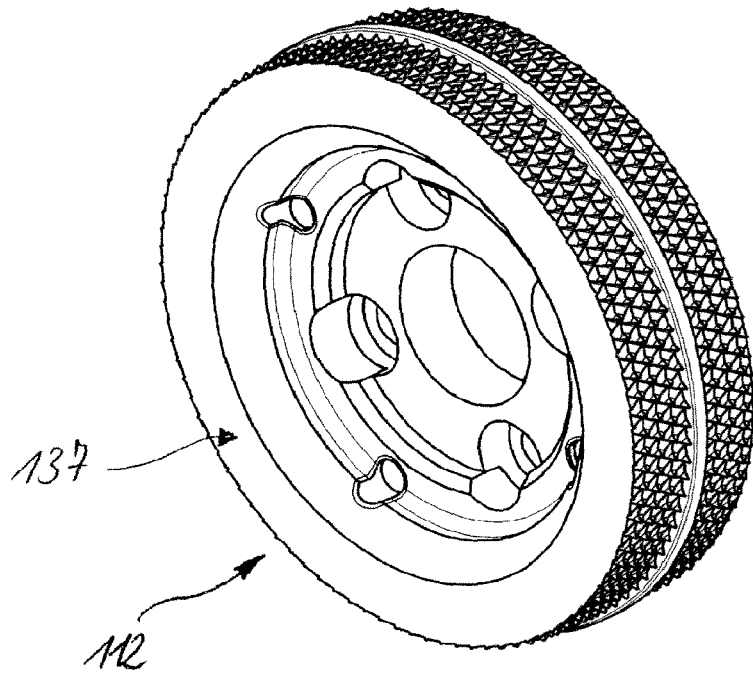

Fig. 15

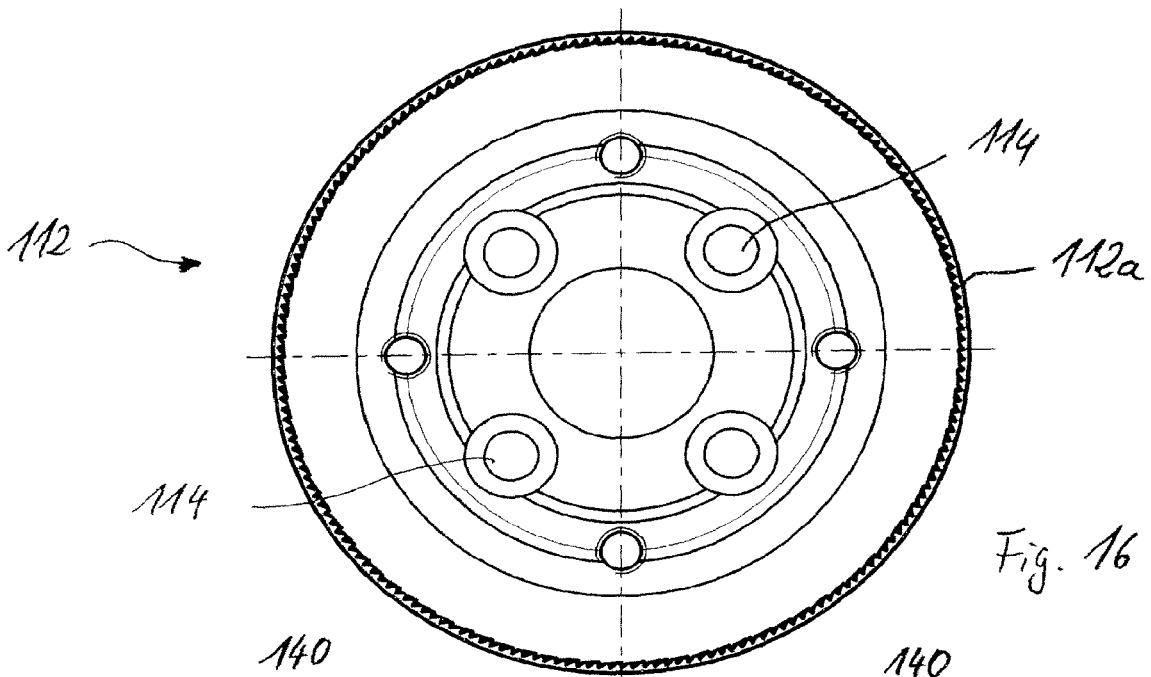

Fig. 16

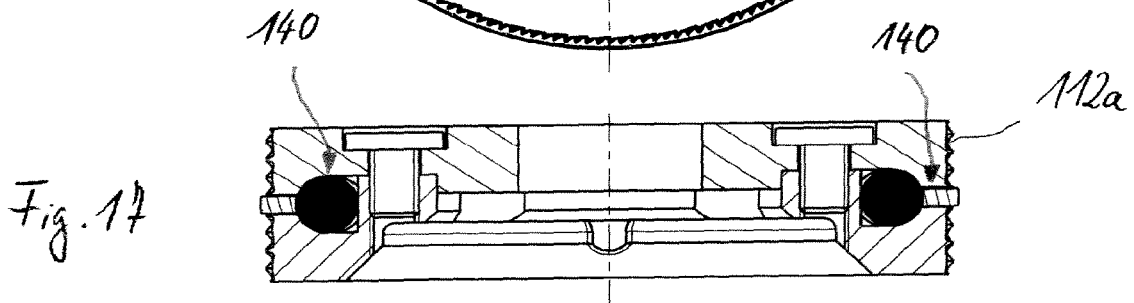

Fig. 17

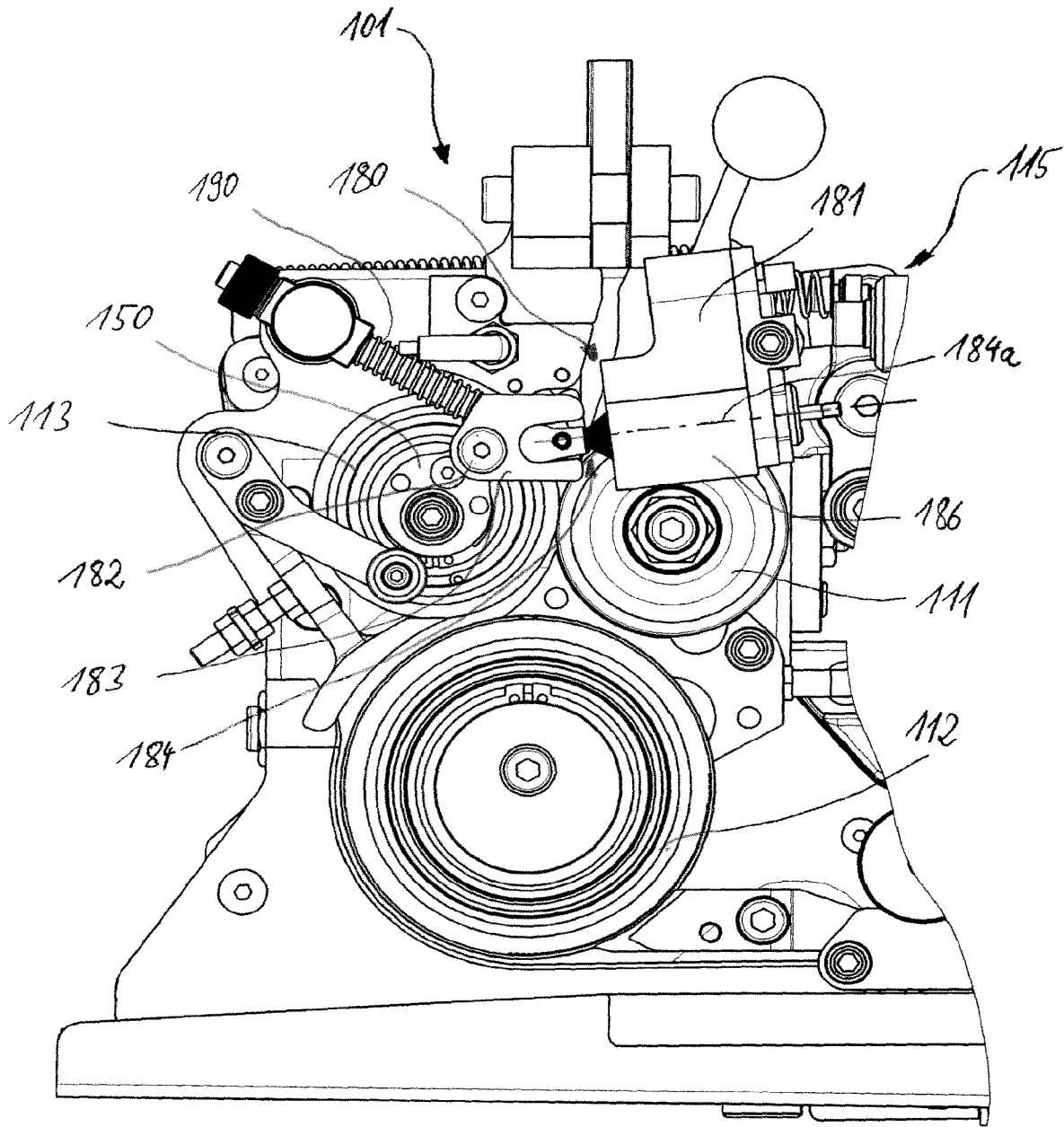

Fig. 18

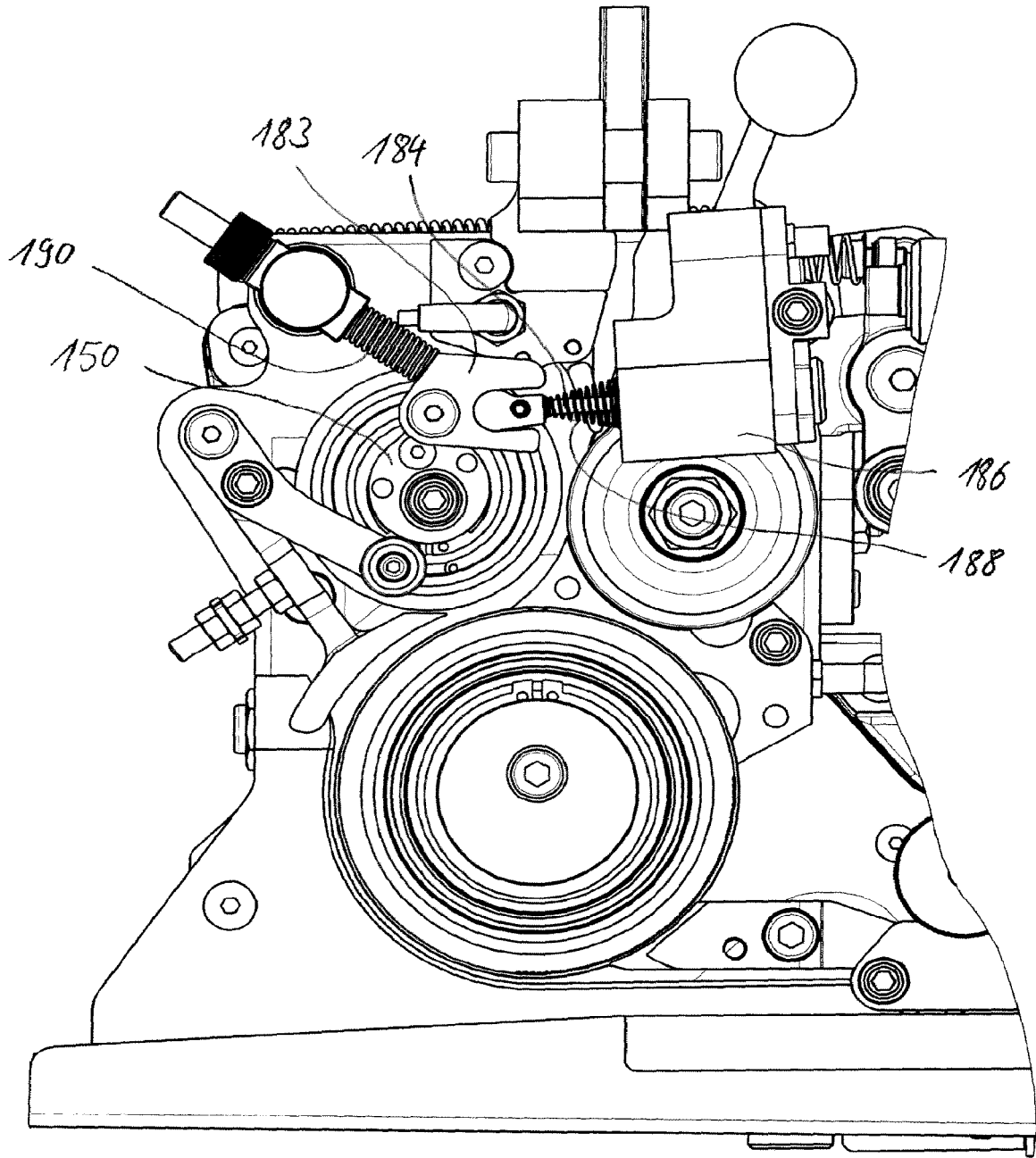

Fig. 19

STRAPPING APPARATUS

This application is a continuation application of U.S. patent application Ser. No. 15/117,403, filed on Aug. 8, 2016 as a national stage entry of PCT/CH2015/000015, filed on Feb. 10, 2015, which claims priority to and the benefit of Swiss Patent Application Nos.: (1) 183/14, filed on Feb. 10, 2014; (2) 182/14, filed on Feb. 10, 2014; and (3) 181/14, filed on Feb. 10, 2014, the entire contents of each of which are incorporated herein by reference.

The present disclosure relates to a strapping device of a strapping apparatus for the strapping of packaged articles with a strapping band, in particular with a plastics strapping band, which is equipped with an advancement and tensioning device which are equipped with multiple wheels for transmitting an advancement, retraction and tensioning movement to the strapping band, wherein at least one of said wheels is operatively connected or operatively connectable to a drive device to set the at least one of the wheels in rotational motion about an axis of rotation for the advancement, retraction and tensioning movement.

Strapping apparatuses of said type, like those to which the present disclosure also relates, may be formed as a static installation which is utilized for equipping relatively large packaged articles, or multiple individual packaged articles placed together to form a packaged article unit, with one or more band straps. The band straps are normally formed from a band which is drawn from a supply roll and laid as a ring-shaped strap around the packaged article. For this purpose, the strapping band is shot with its free end first into a channel of the strapping apparatus, which channel surrounds the packaged article, with a spacing, in the manner of a portal or in ring-shaped fashion. Normally, as soon as the band end has reached a particular point in the channel, the band end is clamped and the band is then retracted again. As a result, the loop of the strapping band is tightened and the band passes out of the channel and into contact with the packaged article. Subsequently, the band is pulled taut and, in the process, a band tension is applied to the band, and the band ring or the band loop is equipped with a fastening and is cut off from the supply roll. As strapping band, use is made both of metallic bands and of plastics bands. The strapping apparatuses are normally adapted to the strapping band types used therewith, in particular with regard to the connecting device by way of which two band layers, which lie one over the other in sections, of the strapping bands can be non-detachably connected to one another.

In the case of previously known solutions, the strapping apparatus generally has a band advancement device for the advancement of the strapping band during the formation of a band loop, a band retraction device for the retraction of the strapping band after the formation of the band loop, for the purposes of causing the strapping band to be laid against the packaged article, and a tensioning device, by way of which a band tension in the strapping band laid against the packaged article can be increased, that is to say the band is laid taut against the packaged article. These three functional components normally require a multiplicity of components and in particular rollers to impart the individual movements to the band in a functionally reliable manner. As a result of this, the strapping device, which is normally in the form of a strapping head, is of relatively large construction, and requires a large volume in the strapping apparatus. Furthermore, this results in a high weight of the strapping device.

The present disclosure is therefore based on the object of improving a strapping apparatus for strapping packaged

articles with a strapping band such that the strapping head can be designed to be as compact as possible.

Said object is achieved by way of a strapping device of the type mentioned in the introduction, in the case of which, for the contact with the strapping band during the execution and imparting of the advancement, retraction and tensioning movement to the band, a total of at most three rollers are provided on the strapping head, which rollers come into contact with the strapping band in conjunction with said functions, and here, the at most three rollers can, in each case pairwise in different combinations with one another, be placed in contact with the strapping band on both sides of the strapping band. In an alternative wording, the present disclosure can thus also be seen in that, in the case of a strapping device in which it is the case that, for the band handling, that is to say for the action on the strapping band during the generation of the band movements, a band advancement device, a band retraction device and a tensioning device of the strapping device are provided, and here, a roller whose circumferential surface is provided for making contact with the strapping band is a constituent part of the tensioning device and of the band advancement device and of the band retraction device. With the present disclosure, it is thus proposed that a roller of the strapping device, which roller is provided in conjunction with the band movement and for making contact with the strapping band, performs multiple functions and is thus assigned to multiple functional units of the strapping device. In this way, it is possible to realize a reduction in the hitherto normally provided number of rollers or wheels. The previously customary four rollers for the band handling in conjunction with the imparting of the movement and tension to the band can, by way of the present disclosure, be reduced to only three rollers. Strapping devices according to the present disclosure, which are normally in the form of so-called strapping heads, can be made more compact through the omission of at least one previously provided roller. Furthermore, through the omission of one or multiple rollers, it is possible for the band profile through the strapping head to be simplified, which can furthermore contribute to an increase in functional reliability of such strapping heads.

In certain refinements, by way of the at most three rollers according to the present disclosure, it is also possible, after the tensioning process, for that band section which is situated in the strapping device to be at least partially relieved of tension. Through the reduction of the band tension in the region of the strapping device, the band can be processed more easily during the generation of the connection between the two band layers and during the cutting of the band from the band supply, which has an advantageous effect on the working result. The tension-relieving process may be realized by way of a motor-driven rotational movement of the tensioning wheel in a direction of rotation of the tensioning wheel which corresponds to the opposite of the direction of rotation provided previously during the tensioning process. Since the band loop that has already been generated can be held in position here by way of suitable clamping means, the tension-relieving process has no influence on the band tension in the band loop.

The said one roller may advantageously be a counterpart roller which is itself not driven in rotation about its axis of rotation and which is thus freely rotatable about its axis of rotation. A position of the said one roller should however advantageously be variable in relation to at least one of the two other rollers by way of a driven movement. For the change in position, the said one roller may be attached to a movement device which is driven by motor means or other

means, by way of which movement device the movement for the change in position is effected. At least one of the three rollers, and in certain embodiments only one of the three rollers, should be movable alternately in the direction of in each case one of the two other rollers in order, in a movement end position, to bear together with the in each case one other roller against the band. In such embodiments of the present disclosure, the movable only one roller may thus, as a counterpart roller for two driven rollers, serve primarily for alternately forcing the band against one driven roller and against the other driven roller to reduce or prevent slippage between the band and the driven rollers.

In a further embodiment according to the present disclosure, the movable roller may be provided for performing pivoting movements, in particular driven pivoting movements. Pivoting movements can be generated with particularly little outlay for the purpose of generating the changes in position provided according to the present disclosure. Corresponding movement devices and the drive thereof may be realized in a compact construction and integrated, with little space requirement, in a strapping device according to the present disclosure.

In one embodiment of the present disclosure, the movement of the movable roller may be in the form of a combined stroke movement and pivoting movement. By contrast to a pure pivoting movement along a radius, it is possible in this way to realize either a pivoting movement about a radius with a superposed stroke movement, or else a stroke movement and pivoting movement performed successively in terms of time, by way of which movement it is possible to realize particularly advantageously optimum movement paths and positions of contact of the movable roller against the two further rollers.

An embodiment of the present disclosure has proven to be particularly advantageous in which a first roller is formed as a tensioning roller of the tensioning device and a second roller is formed as a roller of the band advancement and band retraction device, the first and the second roller are operatively connected or operatively connectable to one or more drives for the purposes of generating driven rotational movements of the first and of the second roller, and the third roller, which is movable in terms of its position, is arranged so as to be movable in driven fashion between positions of contact with the first and with the second roller. The movable roller is thus advantageously movable between two end positions and can be arranged in said two end positions, in which the movable roller is provided for performing either a function of the tensioning device or a function of the band advancement and/or band retraction device.

A further embodiment of the present disclosure—which may also be of independent significance independently of the number of wheels, rollers and motors used for the imparting of movements to the band and independently of the design of the tensioning wheel—may provide an actuable means by which at least one wheel of a wheel pair of the advancing device can be switched into a state in which the strapping band can be displaced between the wheel pair in a direction opposite to the band advancement movement, without a corresponding motor drive movement being transmitted to the strapping band. With the present disclosure, provision is thus made for the state of the wheel pair to be changed from a state in which the band is clamped between said wheels, which state permits in particular the advancement of the band, into a state in which the band can move through between the wheel pair regardless of a driven movement of a wheel of the wheel pair. According to the present disclosure, the clamping state between the wheel

pair, which clamping state is provided for the transmission of a motor drive movement via one of the two wheels to the strapping band, is reduced at least to such an extent that slippage or an increased gap can form between the band and the wheel pair. If an enlarged gap between the circumferential surfaces of the wheels is generated in the event of the clamping action being eliminated, said gap should be larger than the band thickness. The clamping action may for example be reduced simply by virtue of a pressure force with which the two wheels are pressed against one another being reduced, for example by way of a variably adjustable magnitude of said pressure force. Such a reduction of the clamping action may alone be sufficient for a strapping band to be able to move between the wheel pairs of its own accord.

The possibility of movement of the strapping band between the wheels of the wheel pair may however alternatively also be realized by virtue of an operative connection between a driven wheel and its drive being eliminated, such that both wheels of the wheel pair are rotatable freely and without a holding torque of the drive device. Such an elimination of an operative connection may be performed for example by way of a switchable clutch in the drive train of the driven wheel. By way of said switchable clutch, it is also possible for the operative connection to be restored in order for a drive movement, in particular a band retraction movement, to subsequently be imparted by the driven roller to the strapping band again.

By way of free rotatability of the wheel pair, or at least slippage or an adequately large gap between the wheels, it is made possible for the strapping band, immediately after or even during the generation of the band loop, to discharge excess band length of the band loop through between the wheel pair, whereby it is sought to as far as possible prevent the formation of a convolution. An incipient excess band length in the strapping channel leads to buckling in the band loop and thus to compressive and/or bending stresses in the strapping band. Normal strapping bands exhibit a flexural rigidity which has the effect that such bands have the tendency to dissipate compressive and bending stresses by seeking to assume planar and rectilinearly running orientation. This is advantageously utilized by the present disclosure in that, through the creation of a possibility for movement of the band through between the wheel pair, excess band length can move in particular of its own accord out of the band channel again between the wheels owing to the self-relaxation of the band.

In a refinement of said further aspect of the present disclosure, a strapping device in the case of which an advancing movement of the band through the strapping device is provided for the formation of a band loop and, here, the band is clamped between a motor-driven roller and a counterpart roller, a clearance-generating device can be provided. According to this aspect of the present disclosure, in the case of a strapping device, the clearance-generating device may be provided for performing a clearance-generating process between the driven roller and its counterpart roller, by way of which a spacing between the driven roller and its counterpart roller is generated or enlarged and is subsequently reduced in size again. In this context, therefore, the expression “generating a clearance” may be understood to mean the generation of a spacing.

With this measure according to said further aspect of the present disclosure, it is possible in a particularly functionally reliable manner for the formation of a convolution in the band noose or loop, in particular in the region of a band drive device of the strapping device, such as has hitherto often

5

arisen after the completion of the band advancement process in the case of a high band advancement speed and can lead to malfunctions of the strapping device, to be at least substantially avoided. Excess band can move in the direction of the band store again of its own accord through the gap, enlarged owing to the clearance-generating process, between the two rollers. Such a backward movement of a band section through the enlarged gap between the two rollers may take place automatically, in particular owing to the impetus or the kinetic energy present in the band owing to the band advancement that has previously taken place and the flexural rigidity of the band, without the need for a corresponding motor-generated drive movement to be imparted to the band in the same direction.

It is advantageously possible for the clearance-generating process between the two rollers to be eliminated again before the band retraction process effected by motor drive movement, and for the two rollers to be placed in contact with one another again. The clearance-generating process is thus performed at a time between the band advancement process and the band retraction process. A time overlap between the band advancement process and/or the band retraction process, on the one hand, and the clearance-generating process, on the other hand, is possible here but is not imperative.

In a further expedient embodiment of the present disclosure according to this aspect, the non-motor-driven counterpart roller may be arranged on a rotatable eccentric. Here, the clearance-generating device may act on the eccentric in order, by way of rotation of the eccentric and the eccentricity, to generate between the two rollers a gap which is greater than the band thickness. After the completion of the clearance-generating process, the eccentric can be rotated in the then opposite direction again, whereby the two rollers clamp the band between them again and a band retraction process can be performed by way of the two rollers. Said embodiment of the present disclosure has inter alia the advantage that a fast movement of the counterpart roller for the generation of a spacing to the driven roller, and an advancing movement toward the driven roller again, are possible by way of an eccentric with a relatively small structural space requirement. In other embodiments of the present disclosure, the spacing between the two rollers for the clearance-generating process may self-evidently also be realized in some other way, for example by way of a pivoting movement or a linear movement of at least one of the two rollers.

In a further expedient embodiment of the present disclosure, it may be provided that the clearance-generating movement is realized by way of a linearly movable driven element such as for example a stroke-performing piston. Such stroke-performing elements are available in a variety of forms and with different drive principles. With such stroke-performing elements, it is possible the drive movement to form particularly functionally reliable clearance-generating devices. Furthermore, with such drive elements, it is also possible with relatively little outlay for existing strapping apparatuses to be retrofitted with a clearance-generating device.

A further embodiment of the present disclosure may provide, for the tensioning device, that, in the region of the circumferential surface of the tensioning wheel, there is provided on the tensioning wheel at least one movable spacer element which can be arranged in a first position and in a second position that differs from said first position, wherein, in the first position, the spacer element can be arranged at least in sections with a first spacing to the axis of rotation of the tensioning wheel and, in the second

6

position, can be arranged with a second spacing, at least in sections, to the axis of rotation of the tensioning wheel, the first spacing differs here from the second spacing, and the spacer element, in at least one of the two positions, projects beyond the circumferential surface of the tensioning wheel. This embodiment thus makes it possible, by way of the at least one spacer element, for the strapping band to be prevented from coming into contact with the surface of the tensioning wheel when the spacer element assumes its position in which it projects at least in sections beyond the circumferential surface of the tensioning wheel.

In an embodiment of the present disclosure, it may be provided that, by way of a force externally applied to the spacer element of the tensioning wheel, the spacer element can be transferred at least in sections from the position with the relatively large radial spacing to the axis of rotation into the other position with the relatively small radial spacing to the axis of rotation. The expression "externally applicable" may in this case be understood in particular to mean that the force is applied by an element which does not belong to the tensioning wheel or to the spacer element itself. The spacer element may be in the form of a passive element with regard to its change in position or the change in its geometrical shape. A structurally simple and nevertheless compact embodiment of the present disclosure may provide that the spacer element is arranged so as to be rotatable together with the tensioning wheel.

It may be provided that the at least one spacer element assumes its first position during the band retraction phase, such that, during the band retraction phase, the strapping band is arranged against the at least one spacer element of the tensioning wheel and thus with a spacing to the circumferential surface of the tensioning wheel. The band is thus ideally prevented by the spacer element from coming into contact with the circumferential surface of the tensioning wheel during the band retraction phase. If such contact is not entirely avoidable, said contact should however at least be reduced to the greatest possible extent by the spacer element. For the tensioning phase or the tensioning process, it is by contrast possible, in certain embodiments of the present disclosure, for the at least one spacer element to be moved with at least one of its sections into the second position thereof in which, at those points of the circumferential surface at which the tensioning wheel is looped around by the strapping band, said at least one spacer element is arranged no higher than the same height as the circumferential surface, or is arranged lower than said circumferential surface. In this way, the spacer element leaves the circumferential surface free for the desired contact with the circumferential surface during the tensioning process.

As a spacer element, both passive and active spacer elements may be provided for the purposes of moving the at least one spacer element into its two positions. Active elements may be understood as elements which perform a change in position or shape automatically, for example elements which perform self-generating changes in position and/or shape of the spacer element through the use of hydraulic or pneumatic energy or the use of electrical or magnetic energy. By contrast, however, certain embodiments include passive spacer elements, that is to say spacer elements which have a change in position and/or shape externally forcibly imparted to them, without the spacer element itself contributing to this. A change in position or shape may be realized for example by way of a counterpart roller which imparts a pressure force in the direction of the tensioning wheel and presses the band against the spacer element. In the presence of a correspondingly high force

coordinated with the characteristics of the spacer element, it is possible in this way for the region of the spacer element to be provided with a smaller spacing to the axis of rotation of the tensioning wheel than in the unloaded state. The change in spacing may be utilized to the effect that, in the region of the counterpart roller, the strapping band bears now not against the spacer element but against the circumferential surface of the tensioning wheel.

Another embodiment of the present disclosure may provide both a counterpart roller, which imparts force in the direction of the tensioning wheel, and the utilization of the band for generating the change in position. In this way, it is possible for the change in position and/or shape of the spacer element to be realized in a particularly functionally reliable manner. Here, it may be advantageous if in particular at the start of the tensioning phase, the band is forced against the spacer element by way of a counterpart roller or some other suitable element and, in this way, the spacer element is, at least in the region of the counterpart roller, forced back such that the band comes into contact with the circumferential surface. In this way, the band enters into engagement with the tensioning wheel, whereby it is possible to commence with increasing the band tension. As a result of this, the band begins to lie against the spacer element over an at least substantially predetermined wrap angle corresponding to its provided band guidance around the tensioning wheel. By way of an increase of the band tension, it is then also possible for the pressure force to be increased to a magnitude sufficient to force the spacer element back in the region of contact with the band, in such a way that the band is, over its wrap angle on the tensioning wheel, in contact with the circumferential surface of said tensioning wheel. Here, it is particularly advantageous for the spacer element to be forced back to such an extent that the spacer element, at least over a part of the wrap angle (and in certain embodiments substantially over the entire wrap angle) does not project beyond the contact region of the circumferential surface with the band. It is thus possible for the tensioning wheel to remain in engagement by way of its non-smooth circumferential surface even in the presence of further increasing band tension, and the band tension can be increased up to an intended value.

In this context, the expression “do not project beyond the circumferential surface” can also be understood to encompass arrangements in which the spacer element projects only slightly beyond the circumferential surface, and the strapping band, for example owing to its elasticity and deformability, can come into contact with the circumferential surface despite said small projecting length.

In a further embodiment of the present disclosure, the circumferential surface of the tensioning wheel may, at least over a part of the length of the circumference, be equipped with a groove in which, as a constituent part of the spacer element, there may be arranged a ring element which can be arranged at least in sections in different positions. Here, the ring element may advantageously be arranged in a first position, in which it is elevated at least in sections in relation to the circumferential surface, and in a second position, in which the ring element, at least in sections, does not project beyond the circumferential surface.

Basically, a multiplicity of different solutions is conceivable by way of which the spacer element, such as for example the ring element, prevents the strapping band from coming into contact with the surface, which is intentionally kept non-smooth, of the tensioning wheel. A particularly advantageous solution may provide that the ring element extends substantially over the entire circumference of the

tensioning wheel and is arranged in a groove which extends over the circumference of the tensioning wheel. In an expedient refinement of the present disclosure, it may be possible for the ring element to be forced into the groove by the strapping band under pressure loading, such that, owing to the ring element being forced back in this way, it is the case along a wrap angle that the ring element no longer projects beyond the circumferential surface, and the strapping band can come into contact with the circumferential surface of the tensioning wheel. The ring element may be designed so as to be forced back into the groove in the described manner only under the action of a certain minimum force acting on the ring element. Said minimum force may be predetermined such that it is reached during the tensioning process but not during the band retraction process.

In a further particular advantageous embodiment, it is possible for the ring element, or other embodiments of the spacer element, to be of resiliently elastic form, whereby said ring element immediately and automatically restores itself when correspondingly relieved of the band pressure after having previously been subjected to load. Aside from a high level of functional reliability, this solution also makes it possible to avoid a supply of external energy.

Finally, in a further embodiment of the tensioning device, during the tensioning process, the tensioning wheel rotates and, in relation to a positionally static polar coordinate system of the tensioning wheel, the spacer element is forced into the groove at the at least substantially always identical circumferential section of the tensioning wheel, whereas, at the remaining circumferential section, against which the strapping band does not bear, the spacer element projects in relation to the circumferential surface.

Further embodiments of the present disclosure will emerge from the claims, from the description and from the drawing. The content of disclosure of the patent claims is hereby incorporated by reference into the description. The present disclosure will be discussed in more detail below on the basis of exemplary embodiments which are illustrated purely schematically in the figures.

FIG. 1 is a highly schematized illustration of a strapping apparatus according to the present disclosure which is equipped with a strapping head according to the present disclosure.

FIG. 2 is a perspective illustration of a strapping head according to the present disclosure.

FIG. 3 is a perspective illustration from above of the strapping head from FIG. 2 integrated into a band guide of a strapping apparatus.

FIG. 4 shows a side view of the strapping head from FIG. 2, in the case of which a component is situated in a pivoted-out servicing position.

FIG. 5 is a perspective partial illustration of the strapping head from FIG. 2, with the band drive device being illustrated.

FIG. 6 shows a front view of the band drive device from FIG. 5.

FIG. 7 is a perspective illustration of a tensioning wheel according to the present disclosure with a partial illustration of the knurling of the circumferential surface of the tensioning wheel.

FIG. 8 shows a front view of the tensioning wheel from FIG. 7.

FIG. 9 is a cross-sectional illustration of the tensioning wheel along a diameter line.

FIG. 10 shows a component of a lever mechanism for a counterpart roller of the band drive device.

FIG. 11 shows a further component of the lever mechanism of the counterpart roller in a perspective illustration.

FIG. 12 shows the component from FIG. 11 in a front view.

FIG. 13 is a sectional illustration of the component from FIGS. 11 and 12.

FIG. 14 is an exploded illustration of a further exemplary embodiment of a tensioning wheel.

FIG. 15 is a perspective illustration of the tensioning wheel from FIG. 14.

FIG. 16 shows a front view of the tensioning wheel from FIGS. 14 and 15.

FIG. 17 is a sectional illustration of the tensioning wheel from FIGS. 14-16.

FIG. 18 shows a further exemplary embodiment of a band drive device according to the present disclosure with a clearance-generating device in a partial illustration of a strapping head.

FIG. 19 shows the band drive device from FIG. 18 in an illustration in which a clearance has been generated between a counterpart roller and the driven roller that interacts therewith.

FIG. 1 shows a strapping apparatus 1 which is equipped with a controller 2, a supply device 3 for storing and making available a strapping band, and with a strapping head 5. The strapping head 5 serves inter alia for the generation of an advancement movement and for the generation of a retraction movement of the strapping band. Said strapping head is furthermore equipped with a tensioning device, for imparting a band tension to a band loop, and a fastening device for generating a fastening on the strapping band. Furthermore, the strapping apparatus has a band guide 6 by way of which the band can be mechanically and automatically laid around a packaged item 7 on a predefined path. A welding and clamping unit 16 is also integrated into the strapping head 5. Aside from the strapping head 5, these are components that are known per se of strapping apparatuses.

The strapping head 5, which is arranged together with the band guide 6 on a frame 8 and which is separately illustrated in FIG. 2 has a band drive device 15. Band drive devices are basically already known, for which reason substantially the differences in relation to previously known band drive devices will be discussed below. The band drive device according to this exemplary embodiment may be equipped in particular with one or more roller pairs 11, 12; 13 and possibly with further individual diverting rollers. The latter however do not participate in the generation of the band movement and are provided only for determining the band running direction. Of the three rollers 11, 12, 13 in the exemplary embodiment which generate the band movements, at least one of the rollers 11, 12, 13 should be motor-driven for the purposes of generating a band advancement or band retraction movement. Here, in each case one roller 11, 12, 13 of the roller pairs formed from said rollers, between which roller pairs the strapping band is led through and in the process an advancement, retraction or tensioning movement, and possibly a tension-relieving movement, is transmitted to the band, should be driven.

The strapping head 5 has two components: a control component 16 and a band handling component 17. In the exemplary embodiment, the control component 16, aside from the execution of control functions for the components of the strapping device, has further functions, for example the generation of fastenings between the two belt layers of a strap and the cutting of the strapping band from the band supply. The control component 16 is in this case mounted on a partial carrier 18 of the strapping head, wherein the partial

carrier 18 is in turn detachably fastened to a common main carrier 19 of the strapping head 5. As can be seen in particular from FIG. 4, the partial carrier 18 of the control component 16 is pivotable about an axis 23. The elements of the band handling component 17 are fastened, without a dedicated partial carrier, directly to the main carrier 19 of the strapping head. In the exemplary embodiment, the control component 16 is provided substantially for performing control and coordination functions out of the functions performed by the strapping head. The band handling component 17 and the components attached thereto are, by contrast, provided for acting directly on the strapping band.

A band advancement device 20, a band retraction device 21 and a tensioning device 22 are integrated into the band handling component 17 of the strapping head 5. In the exemplary embodiment shown here, common rollers 11, 12; 13 are provided for the band advancement, band retraction and tensioning devices 20, 21, 22. Of the total of only three rollers 11, 12, 13, two rollers 11, 12 are motor-driven rollers. The two rollers 11, 12 are driven by the same (only one) motor 14, in the exemplary embodiment an electric motor. For this purpose, it may for example be provided that, from the common motor 14, in each case one drive train leads to one of the two rollers 11, 12. Here, the roller 11 is provided both as a drive wheel for the band advancement (band advancement wheel) and as a drive wheel for the band retraction (band retraction wheel). In order that, in the exemplary embodiment illustrated, said two functions can be performed by way of only one wheel, the roller 11 can be driven in both directions of rotation by the same drive motor 14. Here, in the illustration of FIG. 6, the direction of rotation counterclockwise is the band advancement direction, and the direction of rotation clockwise is the band retraction direction. As shown in FIG. 2, the motor drive movement is transmitted to both wheels or rollers 11, 12 by the common motor 14 by way of a mechanism device. In the present exemplary embodiment, the mechanism device 14a comprises a toothed-belt mechanism which transmits the drive movement from the motor shaft to a further shaft running parallel to the motor shaft. On said further shaft there are arranged two gearwheels which belong in each case to a further one of two partial mechanisms of the mechanism device. One of said two partial mechanisms of the mechanism device transmits the motor drive movement to the roller or the wheel 11, and the other partial mechanism transmits the motor drive movement to the tensioning wheel 12. Depending on the direction of rotation of the motor shaft, it is thus the case in the exemplary embodiment that both the tensioning wheel 12 and the wheel 11 rotate in different directions of rotation.

In the installed position of the strapping head depicted in FIGS. 5 and 6, the roller 11 is arranged above the roller 12. The roller 12 is a constituent part of the tensioning device 22 and has the function of the tensioning wheel. Said roller has a considerably greater diameter than the roller 11. The tensioning wheel 12, owing to the rigid connection to the motor 14 and the drive movements in both directions of rotation performed by the motor, can likewise be driven in both directions of rotation. For the imparting of the intended band tension to the strapping band, in particular to the band loop, the tensioning wheel however utilizes only the drive movement in the tensioning direction, that is to say the clockwise direction of rotation as viewed in the illustration of FIG. 6. In certain embodiments, a release of tension from the band section which is situated in the strapping head, and which is no longer part of the band loop, may be realized by way of a rotational movement of the tensioning wheel,

11

taking place after the tensioning process, in the direction of rotation opposite to that during the tensioning process. The drive movements both for the tensioning movement and for the tension-relieving movement originate from the same drive motor as for the roller 11. As an alternative to the exemplary embodiment of the present disclosure illustrated here, it is possible in other embodiments for a switchable clutch to be provided in the drivetrain (not illustrated in any more detail) from the motor to the two rollers 11, 12, by way of which clutch the drive movement can be conducted either to the roller 11 or to the roller 12. Aside from embodiments in which the tensioning wheel is in turn capable of being driven in both directions of rotation, it may also be provided that the tensioning wheel can also be driven only in the direction of rotation provided for the tensioning process.

As can be seen from the illustration of FIG. 6, the roller 13 is adjacent both to the roller 11 and to the tensioning wheel 12. The roller 13 is not driven in rotation and is pivotably articulated by way of a pivoting device. The pivoting device is operatively connected to a drive by way of which the roller can perform (motor-) driven pivoting movements. By way of the pivoting movement, the roller 13 which functions as counterpart roller can be placed either in contact with the roller 11 or in contact with the tensioning wheel 12, wherein, in the respective end position of the pivotable roller 13, the strapping band is situated in each case between one of the rollers 11, 12 and the roller 13. Depending on which of the rollers 11, 12 the counterpart roller 13 bears against, the counterpart roller 13 then forces the band against the corresponding roller 11, 12 such that the corresponding roller 11, 12 can transmit its rotational movement with the least possible slippage as an advancement, retraction or tensioning movement, and possibly as a tension-relieving movement, to the strapping band. The counterpart roller 13 is thus, together with the roller 11, both a constituent part of the band advancement device and a constituent part of the band retraction device. Together with the tensioning wheel 12, the counterpart roller 13 is also a constituent part of the tensioning device 22. By way of this configuration according to the present disclosure, it is possible for the fourth roller that has hitherto been conventional in previously known solutions to be dispensed with. In the case of said previously known solutions, the drive roller and the tensioning wheel are in each case fixedly assigned one of two counterpart rollers. The 3-roller solution according to the present disclosure can permit a considerably more compact embodiment in relation thereto.

The rollers 11, 12, 13 are, in the strapping head 5, furthermore a constituent part of a band guide channel 28 which predefines the profile and the advancement and retraction path of the band. The band guide channel 28 is in turn part of the band guide 6. As can be seen in FIG. 6, the strapping head 5 has a first interface 29 at which the strapping head 5 adjoins the supply roll side of the band guide. That end of the band guide channel 28 which is formed here is in the form of a quick-change interface. This has a channel piece 31 which can be clamped to the strapping head by way of a pivotable clamping lever 30 and through which the band is supplied into the strapping head. The channel piece 31 ends directly in front of the circumferential surface 11a of the roller 11, such that the strapping band can be supplied at least approximately tangentially to the circumferential surface 11a of the roller 11. If the roller 13 is situated in its end position in which it is pivoted toward the roller 11, the band is led through between the rollers 11, 13, wherein the roller 13 forces the band against the roller 11.

12

As viewed in the band advancement direction 32, the band passes, in its further progression, to the tensioning wheel 12. Here, proceeding from the counterpart roller 13, a circular-arc-shaped channel section 28a which extends over approximately 180° of the circumference of the tensioning wheel 12 is formed by way of suitable channel-forming means. With regard to the band thickness, the channel section 28a is formed so as to be considerably wider than the band thickness. The inner delimitation of the channel section is formed by that section of the circumferential surface 12a of the tensioning wheel 12 which is situated in each case in the region of the channel section. The outer delimitation of the channel section 28a as viewed radially has guide plates and an outer channel segment which is pivotable together with the counterpart roller 13, by way of which outer channel segment the outer channel section can be kept closed despite the pivotable counterpart roller 13 being situated in the region of the outer channel section. Without the pivotable channel segment 33 or some other element of similar action, there would possibly be an open point of the channel section at least in one of the two pivoting end positions of the counterpart roller 13, which open point could possibly have an adverse effect with regard to reliable band guidance.

FIGS. 7, 8 and 9 show the tensioning wheel in three illustrations. Said tensioning wheel has a ring 37 which is equipped with a recess 38 which is provided for the connection of the tensioning wheel 12 to a shaft of the drive, in particular to a shaft of a mechanism of the drive. FIG. 2 shows the tensioning wheel 12 mounted on the shaft. As can likewise be seen from FIG. 6, the circular tensioning wheel has a circumferential surface 12a with an at least substantially constant width. The tensioning wheel 12 is equipped, on its circumferential surface 12a, with a knurling or toothing 39 by way of which the engagement conditions of the tensioning wheel 12 on the strapping band are improved. Instead of a knurling or toothing 39, it would also be possible for any other geometrically defined or undefined roughening of the circumferential surface 12a of the tensioning wheel to be provided, by way of which possible slippage between the tensioning wheel and the strapping band during the tensioning process can be at least substantially prevented.

A groove 40 with a relatively small width is formed over the entire circumference of the circumferential surface 12a at least approximately centrally—in relation to the width of the tensioning wheel 12—and so as to be spaced apart from the lateral edges of the tensioning wheel, which groove is formed so as to be considerably deeper than it is wide. In the exemplary embodiment, two resiliently elastic O-rings 43, 44 are situated one above the other in the groove 40, said O-rings being arranged radially one behind the other in the groove 40. Here, one of the O-rings 43 is arranged with a relatively small spacing to the axis of rotation of the tensioning wheel 12, and the other O-ring 44 is arranged with a relatively large spacing to the axis of rotation of the tensioning wheel 12. The width of the O-rings 43, 44 is in this case provided so as to approximately correspond to the width of the groove 40. The two O-rings 43, 44 are situated entirely within the groove 40. The two O-rings 43, 44 are formed from resiliently elastic material.

On the outer of the two O-rings 43, 44 there is seated a ring 45 which is provided as a spacer element and which, in the exemplary embodiment, is formed from a metallic material. In this exemplary embodiment, the ring 45 is elastically deformable. It would likewise be possible for the ring to be of substantially rigid or dimensionally stable form. To realize said elastic characteristics of the ring, it would

13

also be possible for the ring 45 to be formed from one or more materials other than a metallic material, for example from an elastic plastic. In the exemplary embodiment, said metal ring 45 is, in terms of its cross section, provided so as to have a width B smaller than its height H. The height of the O-ring is, with regard to the groove depth and the height of the O-rings, configured such that the ring projects with a height H_1 out of the groove 40. Thus, in its unloaded state shown in FIG. 9, the ring 45 projects beyond the circumferential surface 12a of the tensioning ring 12, in particular over its entire circumference or over the entire circumference of the tensioning ring 12.

At the start of the strapping process, the strapping band is pushed at high speed, with its free band end first, from the strapping head 5 through the band guide 6. For this purpose, the counterpart roller 13 is in contact with one side of the band. The band is forced with its other side against the motor-driven roller 11 by the counterpart roller. The rotational drive movement of the roller 11 in the advancement direction is in this way transmitted to the strapping band, which effects the advancement movement thereof in the advancement direction. Downstream of the region in which the band emerges from the gap between roller 11 and counterpart roller 13, the band comes into contact with the tensioning wheel 12, but without exerting a significant pressure on the tensioning wheel 12.

After the band has been pushed all the way through the band guide 6, the band end reaches the closure head again. Here, the band end actuates a limit switch, whereby the advancement movement is stopped and the band end is clamped. These and other activation and deactivation processes of components of the closure head are performed by the control component 16 which, for this purpose, is equipped with a motor-driven camshaft control arrangement such as is basically known.

The camshaft control arrangement of the control component 16 now sets the roller 11 in motion in a direction of rotation reversed in relation to the advancement direction. The strapping band, which remains clamped between the roller 11 and the counterpart roller 13, is hereby moved in the reverse direction, that is to say in the band retraction direction 48. The circumferential length of the band loop, the band end of which remains clamped, is hereby continuously shortened. The band is hereby pulled out of the band guide 6 and, as a result, laid around the respective packaged item.

FIG. 6 illustrates the tensioning wheel 12 during the band retraction process. As can be seen from said illustration, it is the case during the band retraction process that the band comes into contact with the tensioning wheel 12. The strapping band bears against the tensioning wheel 12 substantially over the entire circular-arc-shaped channel section 28a, similarly to the situation also encountered during the subsequent tensioning process. The band is duly retracted here, but, owing to its ability to yield to said movement by moving, as intended, out of the band guide, it is nevertheless the case during said phase that only a relatively low band tension is applied to the band of the band loop. As a result of said contact with the tensioning wheel 12 and of the ring 45 which projects in relation to the circumferential surface, the band bears not against the circumferential surface of the tensioning wheel 12 but against the ring 45 situated in the circumferential surface 12a. Said contact with the spacer element, which, in the exemplary embodiment, is in this case in the form of a ring 45, has the effect that, during the band retraction, the band cannot be damaged by the knurling or toothing 39 of the circumferential surface 12a.

14

After the band has been laid against the packaged article as a result of the band retraction, the controller switches from band retraction to generation of a band tension, whereby it is the intention for the band laid against the packaged article to be pulled taut. For this purpose, it is firstly the case that the counterpart roller 13 is pivoted from its position of contact against the roller 11 into a position of contact against the tensioning wheel 12. The tensioning wheel 12, which is rotated in the same direction of rotation as the roller 11 was previously, rotates at a lower rotational speed but with a greater torque, and pulls further on the strapping band. Owing to the absence of pressure of the counterpart roller 13, it is by contrast now the case that the band no longer bears against the roller 11, which continues to be driven in the exemplary embodiment and which rotates at a higher speed, in such a way that the roller 11 could transmit its movement to the band. Since, at this stage, the strapping band already bears against the packaged article, the band is, by the tensioning wheel 12, retracted at most over a short length in relation to the band retraction phase. During said tensioning phase, it is in particular the case that a relatively high band tension is applied to the band.

Already at the start of the tensioning phase, the pressure of the counterpart roller 13 in the direction of the tensioning wheel and the band situated in between causes the ring 45 to be forced in the direction of the groove base and thus also in the direction of the axis of rotation of the tensioning wheel 12 as viewed in a substantially radial direction. In this way, it is the case already at the start of the tensioning phase that the band bears against the ring 45 and forces the latter likewise, at least in the region of the counterpart roller 13, in the direction of the groove base. Thus, already at the start of the tensioning process, the ring 45 has, in the region of the counterpart roller 13, a smaller spacing to the axis of rotation of the tensioning wheel than in its unloaded state, for example during the band advancement or the band retraction phase.

The torque transmitted from the tensioning wheel 12 to the band during the further course of the tensioning process, which torque is higher than that in the band retraction phase of the roller 11, results in a greater reaction force of the band. Said greater reaction force now has the effect that the band forces the ring 45 into the groove not only in the contact region with the counterpart roller 13 but over its contact length (wrap angle as viewed in the circumferential direction) with the ring 45, whereby the band now bears, along its wrap angle on the tensioning wheel 12, against the circumferential surface of said tensioning wheel. Along its wrap angle on the tensioning wheel, the band forces the ring into the groove counter to the spring forces of the O-rings. Depending on the characteristics of the ring 45, said ring is deformed possibly elastically as a result, and, along that circumferential section in which the strapping band does not bear against the tensioning wheel, said ring can partially (with regard to its height) emerge from the groove again. Outside the wrap angle of the band on the tensioning wheel, the ring 45 may in this case project out of the circumferential surface to a greater extent than in the unloaded state, in the case of which it projects with a height H_1 . Since the ring is arranged rotationally conjointly in the groove, it is the case, in a manner dependent on the respective rotational position of the tensioning wheel 12, that each individual point of the ring is forced into the groove 40, and emerges from said groove again, in alternating fashion until, owing to the rotation of the tensioning wheel, said point arrives again at the point at which the band wraps around a section of the circumferential surface and thereby forces the ring into the

groove along said section. It is thus possible, despite the means provided for preventing the strapping band from coming into contact with the circumferential surface of the tensioning wheel during the band retraction phase, for functionally reliable contact of the band with the same tensioning wheel to nevertheless be achieved during the band tensioning phase.

The counterpart roller **13** can advantageously be forced with different pressing forces firstly against the roller **11** (advancement roller or retraction roller) and secondly against the tensioning wheel **12** (during the use of the strapping device in each case with a strapping band situated in between). Higher pressing forces against the tensioning wheel than the possible pressing forces against the roller **11** can be advantageous for high functional reliability and for the possibility of applying high band tensions to the strapping band. Therefore, below, it will be discussed how, in one embodiment of the present disclosure, despite the pivoting movement of the counterpart roller **13** between two end positions, different pressing forces can be realized in the end position.

For this purpose, the counterpart roller **13** is arranged on an eccentric **50** which, in turn, is arranged on a shaft **51** of a carrier **52**. The carrier has, spaced apart from the shaft **52**, a receptacle **53** which is provided for arrangement on the bearing point **54** of the roller **11** (FIGS. **5** and **6**). Here, the receptacle **53** is freely rotatable about its axis of rotation on the bearing point **54** of the roller **11** and can thus perform pivoting movements about its axis of rotation.

In the region of the counterpart roller **13** and of the roller **11**, there is provided a parallelogram which has multiple levers **57**, **58**, **59** which are pivotably articulated on one another. The parallelogram **56** has a long vertical lever **57**, a horizontal lever **58** and a short vertical lever **59**. The parallelogram is pivotably articulated on the long vertical lever **57** and on the short vertical lever **59**. The levers **57** and **59** have pivot bearing points **60**, **61** for this purpose. Via a bell-shaped curve **62**, it is possible for a rotational movement to be transmitted to the long vertical lever **57**, which rotational movement leads to the pivoting movement of the lever **57** about its pivot bearing point **60**. In the illustration of FIG. **12**, the pivoting movement of the lever **57** takes place clockwise.

In this way, at the articulation point of the short vertical lever, the lever **58** also pulls said short vertical lever in the direction of the lever **57**, whereby the vertical lever **59** is, in the illustration of FIGS. **11** and **12**, likewise pivoted clockwise about its pivot bearing point **62**. As a result, an oblique surface **64** formed on the short vertical lever **59** pushes against a bearing **51** arranged on the shaft **51**. As a result, the oblique surface performs a movement clockwise (in the illustration of FIG. **12**) and has the tendency to assume a horizontal orientation. As a result, the carrier **52** performs a pivoting movement, whereby the counterpart roller **13** is pivoted from its end position against the roller **11** in the direction of the tensioning wheel **12**.

When it reaches the tensioning wheel, the counterpart roller bears against the tensioning wheel and can perform no further pivoting movement. The lever **57** however pivots further, whereby the bearing point **65** of the eccentric **50** is moved counterclockwise in the direction of an L-shaped carrier **66**. After the bearing point **65** pushes against the L-shaped carrier **65**, the movement of the bearing point **65** stops, and said bearing point is situated at least approximately in a line with an upper bearing point **66**, the axis of rotation **67** of the counterpart roller **13** and the axis of rotation **68** of the tensioning wheel **12**. A spring element that

has hitherto generated the pressing force of the counterpart roller **13** is, as a result, no longer active.

A further movement of the lever **57** during its pivoting movement now has the effect that the lever **59** can also perform no further movement, and therefore two parts **58a** and **58b** of the horizontal lever **58** are pulled apart. A spring element **70** arranged between the two parts **58a**, **58b** of the lever is hereby compressed, whereby the spring force thereof increases. This leads to a torque of the lever **59** about the pivot bearing point **61** with the lever arm of the spacing of the pivot bearing point **61** from the articulation point **71** of the lever **58** on the lever **59**. As a result, the oblique surface **64** pushes, in the form of a torque about the pivot bearing point **61**, against the bearing, which now leads to a pressing force of the roller **13** against the tensioning wheel. By way of a correspondingly dimensioned and designed spring element **70** and corresponding lever ratios, it is possible in this way to realize high pressing forces of the roller **13** against the tensioning wheel.

A restoration of the parallelogram can be realized by way of a further spring **73** arranged on the peg **72** of the lever **5**.

Alternative embodiments of components and assemblies discussed above will be described below. Here, substantially only differences in relation to the corresponding components from FIGS. **1** to **13** will be discussed. Where said embodiments include identical or similar configurations to those in the exemplary embodiment of FIGS. **1** to **13**, these will not be discussed in any more detail below; the content of disclosure of the exemplary embodiments of FIGS. **1** to **13** is however also incorporated by reference for the exemplary embodiments of FIGS. **14** to **19**.

FIGS. **14**, **15**, **16** and **17** illustrate a further embodiment of a tensioning wheel **112** according to the present disclosure. The tensioning wheel **112** may be divided longitudinally in terms of its width, approximately in the center, wherein the two parts **112b**, **112c** of the tensioning wheel **112** are detachably connectable to one another by way of suitable fastening elements, for example screws **114**. In the region of said parting plane, which need not run in a flat manner, an encircling groove **140** is formed in the outer ring **137** of the tensioning wheel **112**, which groove is open toward the circumferential surface **112a** of the tensioning wheel **112** and is narrowed or decreased in size toward said circumferential surface.

One or more restoring elements may be arranged in the groove **140**. In the exemplary embodiment, as a restoring element, there are arranged elastic ring sections **143**, for example multiple resiliently elastic O-ring sections **143**. Said ring sections are distributed in the groove **140** at regular intervals with respect to one another, as is the case in the exemplary embodiment with a total of four ring sections **143**. The restoring elements **143** are situated below one or more spacer elements. In the exemplary embodiment, only one spacer element **145**, in the form of a closed ring, is provided. An outer diameter of the ring **145** arranged in the groove is in this case dimensioned such that, in the unloaded state of the ring **145**, said ring projects with its outer circumferential surface beyond the circumferential surface **112a** of the tensioning ring **112**. The ring **145** is situated with its inner circumferential surface in the groove. The restoring elements are attached to the inner circumferential surface of the circular and substantially dimensionally stable ring **145**. In other embodiments, it is also possible for a different number of spacer elements, and a different number of restoring elements, to be provided.

As a result of contact of the strapping band against the ring **145**, and as a result of a certain minimum pressure force

17

being exerted on the ring along a certain angle range along a section of the circumference of the tensioning wheel by the strapping band, it is possible for approximately that section of the ring **145** which projects beyond the groove along said angle range to be forced into the groove **140**, such that, in said positionally static angle range of the tensioning wheel **112**, the strapping band comes into contact with the circumferential surface **112a** of the tensioning wheel **112** and can be driven along by the circumferential surface **112a** during the movement of the tensioning wheel **112**. The ring **145**, which substantially cannot be deformed by the expected forces acting thereon in the exemplary embodiment, and which is thus dimensionally stable, is thus arranged slightly eccentrically in relation to the axis of rotation of the tensioning wheel during said process. The ring **145** hereby projects, with its section not encompassed by the wrap angle of the band, out of the groove **140** further than when the tensioning wheel is in the state in which it is not subject to load by the strapping band. As a result of the ring **145** being relieved of the load of the strapping band, or when a pressure force exerted on the ring **145** by the strapping band is not sufficient, it is possible, after the completion of the tensioning process, for the elastic restoring forces of one or more of the ring sections **143** to cause the ring **145** to project out of the groove again over its entire circumference.

By way of this arrangement, it is possible, during the tensioning process, during which the tensioning band exerts an adequately high pressure force on the ring **145** situated in the wrap region of the strapping band, for the ring **145** to be forced in sections into the groove **140**. During the retraction process, during which only a relatively low tensile stress is present in the strapping band, the pressure force on that section of the ring **145** which is presently arranged in the wrap region of the band is not high enough to force said ring section entirely into the groove **140**. As a result, the band bears against the section of the ring **145** and not against the surface of the tensioning wheel **112**. The ring **145** holds the strapping band so as to be spaced apart from the circumferential surface of the tensioning wheel **112**.

FIGS. **18** and **19** illustrate a further exemplary embodiment of a band drive device **115**. Said band drive device also has only three rollers **111**, **112**, **113** which are responsible for imparting the band advancement, band retraction and band tensioning movements to the band by way of contact with the band, wherein the two rollers **111** and **112** can be driven by way of a motor, in particular by way of only one common motor. The relative arrangement of the axes of rotation of the three rollers **111**, **112**, **113** with respect to one another corresponds at least approximately to the arrangement of said axes of rotation in the exemplary embodiment of FIGS. **5** and **6**.

The counterpart roller **113** is again designed to be pivotable, such that, in one pivoting position, it is provided for pressing the strapping band against the roller **111**, and in another pivoting position, it is provided for pressing the strapping band against the tensioning roller **112**. The pivoting mechanism, provided for this purpose, of the counterpart roller **113**, and the drive of said pivoting mechanism, may in principle be of the same design as in the exemplary embodiment of FIGS. **1** to **13**. As in the exemplary embodiment of FIGS. **5** and **6**, the counterpart roller **113** is rotatably mounted on an eccentric **150**, such that the counterpart roller **113** performs a non-circular-arc-shaped movement during a pivoting movement from one of the rollers **111**, **112** to the respective other roller **111**, **112**. As shown in FIGS. **18** and **19**, a clearance-generating device **180** is mounted on the eccentric **150** of the counterpart roller **113**, wherein the

18

clearance-generating device **180** is supported with a carrier **181** on the frame of the strapping apparatus **101**. The bearing point **182** of the clearance-generating device on the eccentric **150** is itself arranged pivotably on the eccentric, and is in the form of a C-shaped or fork-shaped element **183** to thereby form a receptacle for one end of a piston **184**. Said piston **184** is arranged in displaceable fashion in the carrier **181** of the clearance-generating device **180**. In the illustration of FIGS. **18** and **19**, the support point is situated immediately above the roller **111**. The carrier **181** of the clearance-generating device is in this case likewise mounted in pivotable fashion.

In the exemplary embodiment shown, the clearance-generating device **180** is equipped with a clearance-generating element which is provided for performing a controlled movement by way of which the counterpart roller **113** is acted on in order for the counterpart roller **113**, in its pivoted position against the roller **111**, to be moved such that a clearance is generated, or to be lifted slightly. The counterpart roller **113**, in its pivoted position at the roller **111**, should, even after the generation of a clearance, be able to be placed against the roller **111** again, for example likewise by way of the clearance-generating device. In the exemplary embodiment, the clearance-generating element is in the form of a solenoid **186** which is arranged and mounted on the clearance-generating device **180**. The solenoid **186** can, by way of its piston **184**, perform a linear stroke movement along the longitudinal axis **184a** of its piston **184**. As shown in FIGS. **18** and **19**, one end of the piston **184** is arranged in the recess, which is open toward the carrier **181**, of the C-shaped or fork-shaped element **183**. The end of the piston **184** and the recess of the C-shaped element may in this case be designed such that, during the clearance-generating movement, the end of the piston **184** in the C-shaped element can move relative thereto.

Here, the extended longitudinal axis **184a** of the piston **184** runs at least approximately through the articulation point of the C-shaped element **183**. A stroke movement of the piston **184** in the direction of the counterpart roller **113** thus leads to a rotational movement of the eccentric about its axis of rotation. In the illustration of FIG. **18**, the rotational movement takes place counterclockwise, as can be seen from a comparison of the two FIGS. **18** and **19**. The rotational movement of the eccentric **150** in turn has the effect that the axis of rotation of the counterpart roller **113** is displaced in parallel and a gap, or an enlarged gap, is formed between the roller **111** and the counterpart roller **113**. The width of the gap should in this case have a size greater than the thickness of the strapping band being processed in each case. As a solenoid, use may for example be made of the product GKb-32.06 from the company Isliker Magnete AG, CH-8450 Andelfingen.

On the piston **184** there may be arranged a mechanical spring element, in particular at least one compression spring **188**. Said compression spring **188** is compressed, and thus braced in resiliently elastic fashion, during the movement of the counterpart roller **113** from the tensioning roller **112** into contact with the roller **111**. The electrically actuatable magnetic stroke-performing piston is deactivated, and thus has no action, in this phase. During the stroke movement, the compression spring **188** is at least partially relaxed and the spring force acts so as to assist the force imparted by the solenoid, by way of which force the piston **184** is moved so as to generate a clearance between the counterpart roller **113** and the roller **111**. In other exemplary embodiments, in

which the solenoid or some other restoring element alone provides a force high enough for the clearance-generating process.

During the production of the strap, it is the case—as already described—that, by way of the roller **111** and the counterpart roller **113** which bears against the former roller and clamps the band between the two rollers, the band is moved through the band guide channel **28** in a feed direction. When the strapping band reaches the region of the end of the band guide channel, as is illustrated by way of example in highly schematized form in FIG. **1**, the band strikes a stop, or the fact that the end of the band guide channel has been reached may be detected in some other way, for example by way of a light barrier. In this way, a signal is generated, by way of which the control of the strapping apparatus stops the motor drive movement of the roller **111** and—at least substantially at the same time—triggers the stroke movement of the piston **184** of the solenoid. In other embodiments of the present disclosure, it is also conceivable for the stoppage of the drive movement of the roller **111** and the start of the clearance-generating process to have a time offset with respect to one another, that is to say for the stoppage of the drive movement to be performed before or after the start of the clearance-generating process.

As a result of the starting of the clearance-generating process, the piston **184** deploys in the direction of the C-shaped element **183** and, here, acts by way of its end on the C-shaped or fork-shaped element. Owing to its arrangement on the eccentric **150**, the eccentric is rotated during the stroke movement of the piston. In the exemplary embodiment and in the illustration of FIG. **18**, the rotational movement of the eccentric takes place through a rotational angle of less than 90° counterclockwise. The rotational movement takes place counter to the spring force of the pressure-exerting spring **190**, which in this case is compressed and is likewise articulated on the eccentric **150**. As a result of the rotational movement, a clearance is generated between the counterpart roller **113** and the roller **111**, that is to say the counterpart roller **113** is lifted from the roller **111**, and the spacing between the two rollers **111**, **113** is enlarged such that a gap forms between the rollers, which gap is larger than the band thickness.

In the case of generic strapping apparatuses, the strapping band, which is shot at high speed through the band channel of the band guide **6**, has the tendency, owing to the sudden and abrupt stoppage of the band, to form convolutions between the rollers **111**, **112**, **113** and the end of the strapping channel. In particular in the region of the rollers **111**, **112**, **113**, such convolutions can lead to malfunctions. Owing to the embodiment according to the present disclosure, in which a clearance of the counterpart roller **113** is generated, the band can, in particular immediately after the stoppage of the advancement, move freely counter to the advancement direction in the direction of the band supply to the extent required for that part of the band which is possibly excess in relation to the length of the band channel, and which causes the formation of convolutions, to move back in the band guide channel. The controller of the strapping apparatus can then subsequently deactivate the solenoid again. As a result, the solenoid is rendered inactive, whereby the pressure-exerting spring **190** can move the eccentric **150** back again counter to the previous direction of rotation, and thus move the counterpart roller **113** into its position of contact with the band again, in which the band is clamped between the roller **111** and the counterpart roller **113**. The subsequent band

retraction and tensioning process can be performed in the same way as in the embodiments of the present disclosure as per FIGS. **1** to **13**.

List of reference designations	
1	Strapping apparatus
2	Controller
3	Supply device
5	Strapping head
6	Band guide
8	Frame
11	Roller
11a	Circumferential surface
12	Tensioning wheel
12a	Circumferential surface of tensioning wheel
13	Counterpart roller
14	Motor
14a	Mechanism device
15	Band drive device
16	Control component
17	Band handling component
18	Partial carrier
19	Main carrier
20	Band advancement device
21	Band retraction device
22	Tensioning device
23	Axle
27	Pivoting device
28	Band guide channel
28a	Channel section
28b	Outer delimitation
29	Interface
30	Clamping lever
31	Channel piece
32	Band advancement direction
33	Outer channel segment
37	Ring
38	Recess
39	Knurling/toothing
40	Groove
43	O-ring
44	O-ring
45	Ring
48	Band retraction direction
50	Eccentric
51	Shaft
52	Carrier
53	Receptacle
54	Bearing point
56	Parallelogram
57	Long vertical lever
58	Horizontal lever
59	Short vertical lever
60	Pivot bearing point
61	Pivot bearing point
64	Oblique surface
65	Bearing point
66	Carrier
67	Rotary axle
68	Rotary axle
70	Spring element
71	Articulation point
72	Peg
101	Strapping apparatus
111	Roller
112	Tensioning wheel
112a	Circumferential surface
112b	Part
112c	Part
113	Counterpart roller
114	Screw
115	Band drive device
137	Ring
140	Groove
143	Ring section
145	Ring
150	Eccentric
180	Clearance-generating device
181	Carrier

-continued

List of reference designations	
182	Bearing point
183	C-shaped element
184	Piston
184a	Axis
186	Solenoid
188	Compression spring
190	Pressure-exerting spring
B	Width
H	Height
H ₁	Height

What is claimed is:

1. A strapping apparatus for applying a tensioned strap loop around a load, the strapping apparatus comprising:
 an advancement/retraction roller;
 a tensioning roller, wherein the tensioning roller and the advancement/retraction roller partially define a strap channel;
 a counterpart roller;
 a first drive device operably connected to and configured to drive the advancement/retraction and tensioning rollers;
 a second drive device operably connected to the counterpart roller and configured to move the counterpart roller relative to the advancement/retraction and tensioning rollers from an advancement/retraction position in which the counterpart roller is adjacent the advancement/retraction roller to a tensioning position in which the counterpart roller is adjacent the tensioning roller;
 a fastening device;
 a clamping device;
 a strap guide;
 a sensor, and
 a controller configured to:
 with the counterpart roller in the advancement/retraction position and pressing a first surface of a strap against the advancement/retraction roller, control the first drive device to drive the advancement/retraction roller in an advancement direction to advance the strap through the strap channel and into the strap guide;
 responsive to the sensor detecting the strap:
 control the first drive device to stop driving the advancement/retraction roller; and
 control the clamping device to clamp part of the strap;
 after the part of the strap is clamped, control the first drive device to drive the advancement/retraction roller in a retraction direction opposite the advancement direction to pull the strap out of the strap guide and onto the load;
 control the second drive device to move the counterpart roller toward the tensioning roller from the advancement/retraction position to the tensioning position to press the first surface of the strap against the tensioning roller, wherein the controller is configured to control the second drive device to move the counterpart roller from the advancement/retraction position to the tensioning position independent of operation of the first drive device;
 control the first drive device to drive the tensioning roller in a tensioning direction to tension the strap around the load; and

control the fastening device to attach the strap to itself to form the tensioned strap loop around the load.

2. The strapping apparatus of claim 1, wherein the first drive device comprises a first motor and the second drive device comprises a second motor.

3. The strapping apparatus of claim 1, further comprising a main carrier and a band handling component mounted to the main carrier and comprising the advancement/retraction roller, the tensioning roller, the counterpart roller, and the first drive device.

4. The strapping apparatus of claim 3, further comprising a control component mounted to the main carrier and comprising a partial carrier to which the fastening device and the clamping device are mounted.

5. The strapping apparatus of claim 4, wherein the control component is pivotably mounted to the main carrier such that the partial carrier is pivotable relative to the main carrier about a pivot axis.

6. The strapping apparatus of claim 3, wherein the advancement/retraction roller and the tensioning roller are immovable relative to the main carrier and the counterpart roller is pivotable relative to the main carrier between its advancement/retraction and tensioning positions.

7. The strapping apparatus of claim 1, wherein the counterpart roller is freely rotatable.

8. The strapping apparatus of claim 1, wherein the counterpart roller is pivotable between its advancement/retraction and tensioning positions.

9. The strapping apparatus of claim 8, further comprising a channel segment that partially defines the strap channel along with the tensioning roller and the advancement/retraction roller, wherein the channel segment is pivotable together with the counterpart roller to prevent the strap channel from opening as the counterpart roller moves between its advancement/retraction and tensioning positions.

10. The strapping apparatus of claim 1, further comprising means for causing the counterpart roller to exert different pressing forces against the advancement/retraction roller and the tensioning roller.

11. The strapping apparatus of claim 1, wherein the tensioning roller is rotatable about a rotational axis and comprises a circumferential surface defining a circumferential groove therein, wherein a deformable spacer element is disposed within the groove such that at least part of the spacer element projects from the circumferential surface of the tensioning roller when the spacer element is in an undeformed state.

12. The strapping apparatus of claim 11, wherein the spacer element is deformable such that movement of the counterpart roller from its advancement/retraction position to its tensioning position causes the counterpart roller to exert a force on the spacer element that causes the spacer element to deform such that at least part of the spacer element moves toward the rotational axis of the tensioning roller.

13. The strapping apparatus of claim 12, wherein when the counterpart roller is in its tensioning position the spacer element is deformed such that the at least part of the spacer element does not project from the circumferential surface of the tensioning roller.

14. The strapping apparatus of claim 1, wherein the first drive device is the only drive device operably connected to and configured to drive the advancement/retraction and tensioning rollers.

15. A method of applying a tensioned strap loop around a load with a strapping apparatus, the method comprising:

23

with a counterpart roller in an advancement/retraction position and pressing a first surface of a strap against an advancement/retraction roller, driving the advancement/retraction roller in an advancement direction to advance the strap through a strap channel and into a strap guide; 5

responsive to a sensor detecting the strap:

- stop driving the advancement/retraction roller; and
- clamping part of the strap with a clamping device;

after clamping the part of the strap, driving the advancement/retraction roller in a retraction direction opposite the advancement direction to pull the strap out of the strap guide and onto the load; 10

moving the counterpart roller toward the tensioning roller from the advancement/retraction position to a tensioning position to press the first surface of the strap against a tensioning roller; 15

driving the tensioning roller in a tensioning direction to tension the strap around the load; and

attaching the strap to itself with a fastening device to form the tensioned strap loop around the load, 20

wherein driving the advancement/retraction roller in the advancement and retraction directions comprises controlling a first drive device to drive the advancement/

24

retraction roller in the advancement and retraction directions, wherein driving the tensioning roller in the tensioning direction comprises controlling the first drive device to drive the tensioning roller in the tensioning direction, and wherein moving the counterpart roller from the advancement/retraction position to the tensioning position comprises controlling a second drive device to move the counterpart roller from the advancement/retraction position to the tensioning position independent of operation of the first drive device.

16. The method of claim 15, further comprising controlling the counterpart roller to exert different pressing forces against the advancement/retraction roller and the tensioning roller.

17. The method of claim 15, wherein moving the counterpart roller from the advancement/retraction position to the tensioning position causes a spacer element projecting from a circumferential surface of the tensioning roller to deform such that at least part of the spacer element does not project from the circumferential surface of the tensioning roller and the first surface of the strap engages the circumferential surface of the tensioning roller.

* * * * *