



- (51) International Patent Classification:
A61B 1/24 (2006.01) A61B 13/00 (2006.01)
- (21) International Application Number:
PCT/US2016/069324
- (22) International Filing Date:
29 December 2016 (29.12.2016)
- (25) Filing Language: English
- (26) Publication Language: English
- (30) Priority Data:
62/272,251 29 December 2015 (29.12.2015) US
- (72) Inventor; and
- (71) Applicant : **BARTOZZI, Lennon, Keith** [US/US]; 374 Grand Steeple Drive, Collierville, TN 38017 (US).
- (74) Agent: **BALDRIDGE, Julie, R.**; 165 Madison Avenue, Suite 2000, Memphis, TN 38103 (US).
- (81) Designated States (*unless otherwise indicated, for every kind of national protection available*): AE, AG, AL, AM, AO, AT, AU, AZ, BA, BB, BG, BH, BN, BR, BW, BY, BZ, CA, CH, CL, CN, CO, CR, CU, CZ, DE, DJ, DK, DM,

DO, DZ, EC, EE, EG, ES, FI, GB, GD, GE, GH, GM, GT, HN, HR, HU, ID, IL, IN, IR, IS, JP, KE, KG, KH, KN, KP, KR, KW, KZ, LA, LC, LK, LR, LS, LU, LY, MA, MD, ME, MG, MK, MN, MW, MX, MY, MZ, NA, NG, NI, NO, NZ, OM, PA, PE, PG, PH, PL, PT, QA, RO, RS, RU, RW, SA, SC, SD, SE, SG, SK, SL, SM, ST, SV, SY, TH, TJ, TM, TN, TR, TT, TZ, UA, UG, US, UZ, VC, VN, ZA, ZM, ZW.

- (84) Designated States (*unless otherwise indicated, for every kind of regional protection available*): ARIPO (BW, GH, GM, KE, LR, LS, MW, MZ, NA, RW, SD, SL, ST, SZ, TZ, UG, ZM, ZW), Eurasian (AM, AZ, BY, KG, KZ, RU, TJ, TM), European (AL, AT, BE, BG, CH, CY, CZ, DE, DK, EE, ES, FI, FR, GB, GR, HR, HU, IE, IS, IT, LT, LU, LV, MC, MK, MT, NL, NO, PL, PT, RO, RS, SE, SI, SK, SM, TR), OAPI (BF, BJ, CF, CG, CI, CM, GA, GN, GQ, GW, KM, ML, MR, NE, SN, TD, TG).

Published:

- with international search report (Art. 21(3))
- before the expiration of the time limit for amending the claims and to be republished in the event of receipt of amendments (Rule 48.2(h))

(54) Title: INTUBATION DEVICE

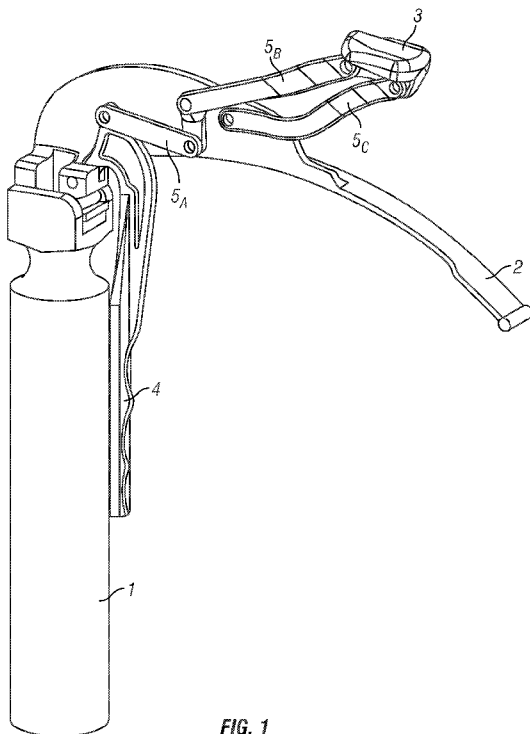

FIG. 1

(57) Abstract: A device used for oral intubation on a patient having a mouth and airway (or oropharynx) is disclosed. The device comprises a hard palate pivot support attached to a laryngoscope blade by a plurality of actuating arms, wherein the hard palate pivot support is used to push against the roof of a patient's mouth and consequently open a patient's airway in order to visualize the vocal chords. A method of use is further disclosed.

Intubation Device

Oral intubation is a procedure by which a tube is inserted through the mouth down into the trachea, the large airway from the mouth to the lungs. The tube is often inserted with the a laryngoscope, an instrument that permits the person inserting the tube to see the upper portion of the trachea, just below the vocal cords. During the procedure, the laryngoscope is used to hold the tongue to the side while the tube is inserted into the trachea. Critical to the procedure is that the head of the patient be positioned in the appropriate manner to allow for proper visualization. Additionally, pressure is typically applied to the thyroid cartilage (or Adam's apple) to allow better visualization of the trachea and to prevent possible aspiration.

Oral intubation is often a difficult medical procedure because the anatomy of some patients makes it difficult to view the patient's vocal chords, which is essential for successful intubation. Examples of patients where oral intubation is difficult include overweight patients, patients with an anterior placed trachea, patients with a short neck such as pediatric patients, and/or patients requiring intubation out in the field in an emergency situation. The existing methods of oral intubation involve prying forward on the patient's upper lip and teeth with the standard laryngoscope blade which often causes injury and, most importantly, results in an unsuccessful intubation or view of the patient's vocal chords. When the laryngoscope blade is tilted back into the upper lip and teeth, injury to the patient, such as broken teeth and lacerations to the interior of the mouth, may occur.

A device for oral intubation that may be easily used to provide successful oral intubation to difficult-to-intubate patients is needed. A device that uses a hard palate pivot support as a safe anchor point to push against the roof of a patient's mouth and consequently open the airway (or oropharynx) in order to visualize the vocal chords is needed.

A laryngoscope for use in pre-hospital and hospital situations is disclosed. The device is designed to increase the success rate of oral intubation of adult and pediatric patients. The device utilizes unique features that allow for one handed operation and use. The one-handed operation allows the healthcare worker performing the intubation to hold the device in one hand and free up the other hand for insertion of the endotracheal tube. The purpose of the

device is to overcome obstacles that present themselves in any intubation situation. This device eliminates the requirement of physical arm strength by utilizing an anatomically friendly design and easy to use handle. The device allows for direct visualization of the vocal chords and will increase the success rate of intubations while decreasing the risk of injury to patients.

BRIEF DESCRIPTION OF THE DRAWINGS:

The present disclosure will be better understood by reference to the following detailed description when considered in conjunction with the accompanying drawings wherein:

FIG. 1 is a perspective view of the intubation device. In such depiction, the device is in the depressed state as the lever is pulled down.

FIG. 2 is a partial back perspective view of the intubation device in FIG. 1.

FIG. 3 is a side perspective view of the intubation device. In such depiction, the device is in not in the depressed state as the lever is not depressed or pulled down.

FIG. 4 is a right side perspective view of the intubation device of FIG. 1.

FIG. 5 is a left side perspective view of the intubation device of FIG. 1 .

FIG. 6 is a top perspective view of the intubation device in use. Such depiction portrays a view of a perspective airway provided by the intubation device.

FIG. 7 is a side perspective view of the intubation device inserted into the mouth of a patient.

FIG. 8 is a front perspective view of the intubation device of FIG. 6.

FIG. 9 is a perspective view of the handle of the intubation device of FIG. 1.

FIG. 10 is a perspective view of the laryngoscope blade of the intubation device of FIG. 1.

FIG. 11 is a perspective view of the actuating lever of the intubation device of FIG. 1.

FIG. 12 is a perspective view of the hard palate pivot support of the intubation device of FIG. 1.

FIG. 13 is a perspective view of a first actuating arm of the intubation device of FIG. 1. Such first actuating arm has two points of connection. It is connected to the actuating lever and a second actuating arm.

FIG. 14 is a perspective view of the second actuating arm of the intubation device of FIG. 1. Such second actuating arm has three points of connection. It is connected to the first

actuating arm. Additionally, such second actuating arm is connected to the laryngoscope blade and the hard palate pivot support.

FIG. 15 is a perspective view of the third actuating arm of the intubation device of FIG. 1. Such third actuating arm is connected to the laryngoscope blade and the hard palate pivot support.

DETAILED DESCRIPTION:

Referring to FIGS. 1 to 15, a device for oral intubation is disclosed. In one example embodiment, the device utilizes a laryngoscope blade 2 and hard palate pivot support 3 that is positioned into the airway (or oropharynx) through the opening in the mouth. The device is unlike any other device in that it utilizes a spring activated lever 4 on the handle 1 that is designed to be easily operated with one hand. In addition to ease of use, the device's design benefits the patient by protecting the patient's teeth, gums, palate and all other soft tissue in the mouth and oropharynx from injury that commonly occurs with the current intubation method. The blade 2 and hard palate pivot support 3 may be collapsed together via the spring (best shown in FIG. 3) for easy insertion; once the device is in the proper position inside a patient's mouth, the lever 4 may be depressed or pulled down spreading the laryngoscope blade 2 and the hard palate pivot support 3 apart at a specific angle and distance from each other. In one embodiment, the device is designed with the proper distance and opening angle to allow for a wide open view of the vocal chords 10 and adequate room for visualization and insertion of an endotracheal tube (best shown in FIGS. 6 to 8).

Referring now to FIG. 3, in one example embodiment, the device is collapsed in its resting state (or non depressed state) making insertion of the device easier. Referring now to FIGS. 1-15, the anatomical design is designed to protect the patient from injury. The laryngoscope blade 2 and hard palate pivot support 3 are offset and positioned for optimal utilization meaning it will open and provide the widest view possible of the trachea. The device is designed to release automatically and pressure is easily controlled by the provider. The handle 1 and lever 4 are designed for easy one handed operation requiring minimal physical strength. The hard palate pivot 3 has two apertures (shown in FIG. 12) and is attached to the blade 2 having two apertures (see FIG. 10) with actuating arms 5B and 5C on the side of the blade 2 to allow for direct visualization and easy insertion of an endotracheal tube.

In one example embodiment, laryngoscope blade 2 has a proximal end and a distal end. The proximal end of the blade 2 attached to handle 1. The distal end of blade 2 is inserted into the mouth of a patient. In one example embodiment, the blade 2 has two apertures for attaching to actuating arms 5B and 5C. The size and the length of blade 2 may vary as desired by one of skill in the art. In one example embodiment, laryngoscope blade 2 has a tip on the distal end. Actuating arm 5A has two apertures on each distal end. Arm 5A is connected to lever 4 at one end and actuating arm 5B at the opposite end. Actuating arm 5B is substantially L-shaped and has three points of attachment. At each distal end of actuating arm 5B, an aperture exists to allow attachment to the pivot support 3 and the actuating arm 5A. Actuating arm 5B is also attached to blade 2 at the perpendicular junction of actuating arm 5B. Actuating arm 5C has two apertures on each distal end. Arm 5C is connected to blade 2 at one end and hard palate pivot support at the opposite end. Actuating arms 5A, 5B and 5C allow movement between the lever 4 and hard palate pivot support 3.

A method of using the device to provide oral intubation to a patient comprises positioning the laryngoscope blade 2 and the hard palate pivot support 3 into the oropharynx through the opening of a patient's mouth. Handle 1 is used to guide the blade 2 into the proper positions. The blade 2 and the hard palate pivot support 3 may be collapsed together to allow them to be inserted between the tongue 16 and the hard palate 14 of the patient 12 (best shown in FIGS. 7 and 8). Once the device is positioned inside the patient's mouth, the actuating lever 4 may be depressed which moves the actuating arms 5A, 5B and 5C, wherein such actuating arms cohesively work together to spread apart the laryngoscope blade 2 and hard palate pivot support 3. This action opens the oropharynx for the necessary view of the vocal chords 10. The endotracheal tube may then be placed through the vocal chords and into the trachea for a successful intubation.

In one embodiment, the device may be made of surgical steel, except for the hard palate pivot support 3, which may be made of a softer synthetic plastic or rubber. The device may be made of other materials as desired by one of skill in the art. Referring to FIGS. 1-15, the hard palate pivot support 3 may be shaped or curved to protect the patient's hard palate 12 from injury. In one example embodiment, the material used may be easily sterilized to allow for multiple uses.

The foregoing disclosure has been set forth merely to illustrate the invention and is not intended to be limiting. Since modifications of the disclosed embodiments incorporating the spirit and substance of the disclosure may occur to persons skilled in the art, the disclosure should be construed to include everything within the scope of the disclosure and equivalents thereof.

I claim:

1. A device used for oral intubation on a patient having a mouth and airway (or oropharynx), the device comprises a hard palate pivot support attached to a laryngoscope blade by a plurality of actuating arms, wherein the hard palate pivot support is used to push against the roof of a patient's mouth and consequently open a patient's airway in order to visualize the vocal chords.

2. A device used for oral intubation on a patient, the device comprises:

a handle;

a laryngoscope blade having a proximal end and a distal end, wherein the proximal end of the blade is attached to the handle;

a lever attached to the blade;

a hard palate pivot support; and

a plurality of actuating arms, wherein a first actuating arm is connected to lever and a second actuating arm, wherein a second actuating arm is connected to the first actuating arm, the blade and the pivot support, wherein a third actuating arm is connected to blade and the hard palate pivot support.

3. A method for providing oral intubation procedure to a patient, wherein such method comprises the following steps

a. obtaining an oral intubation device disclosed in claim 2;

b. positioning the laryngoscope blade and the hard palate pivot support of the device into the oropharynx through the opening of a patient's mouth;

c. depressing the actuating lever until the laryngoscope blade and hard palate pivot support open the oropharynx for the necessary view of the vocal chords; and

d. inserting a endotracheal tube through the vocal chords and into the trachea.

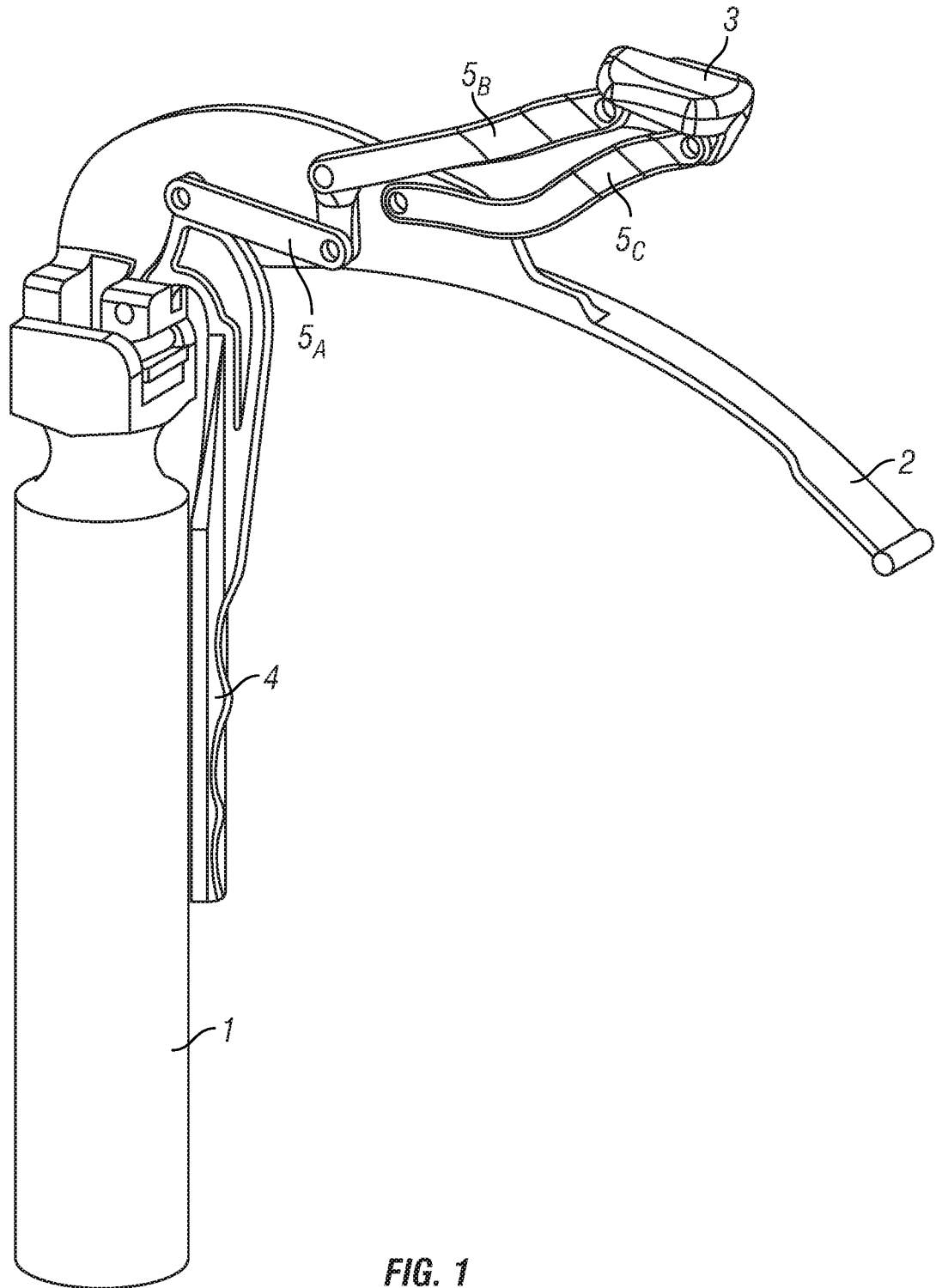

FIG. 1

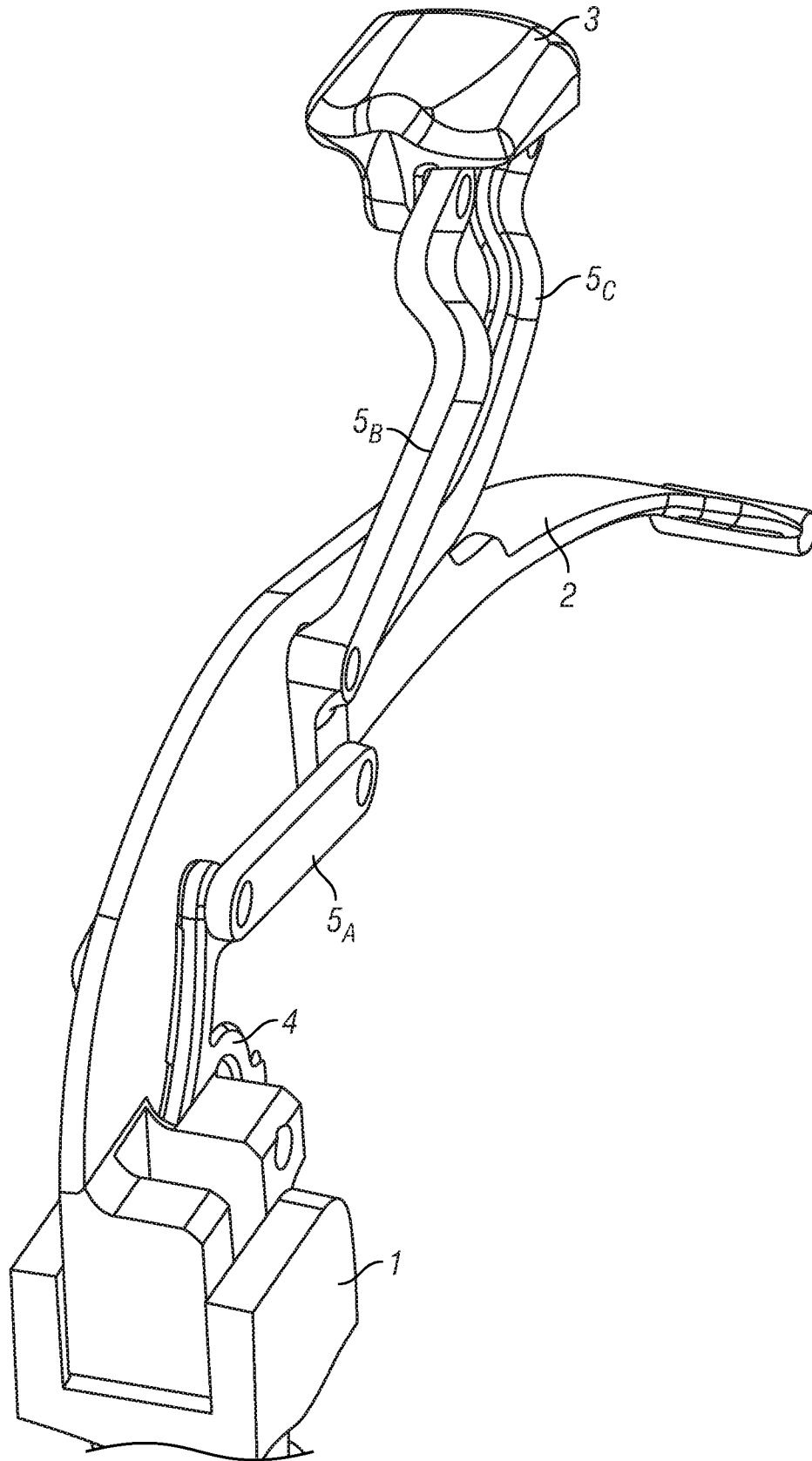

FIG. 2

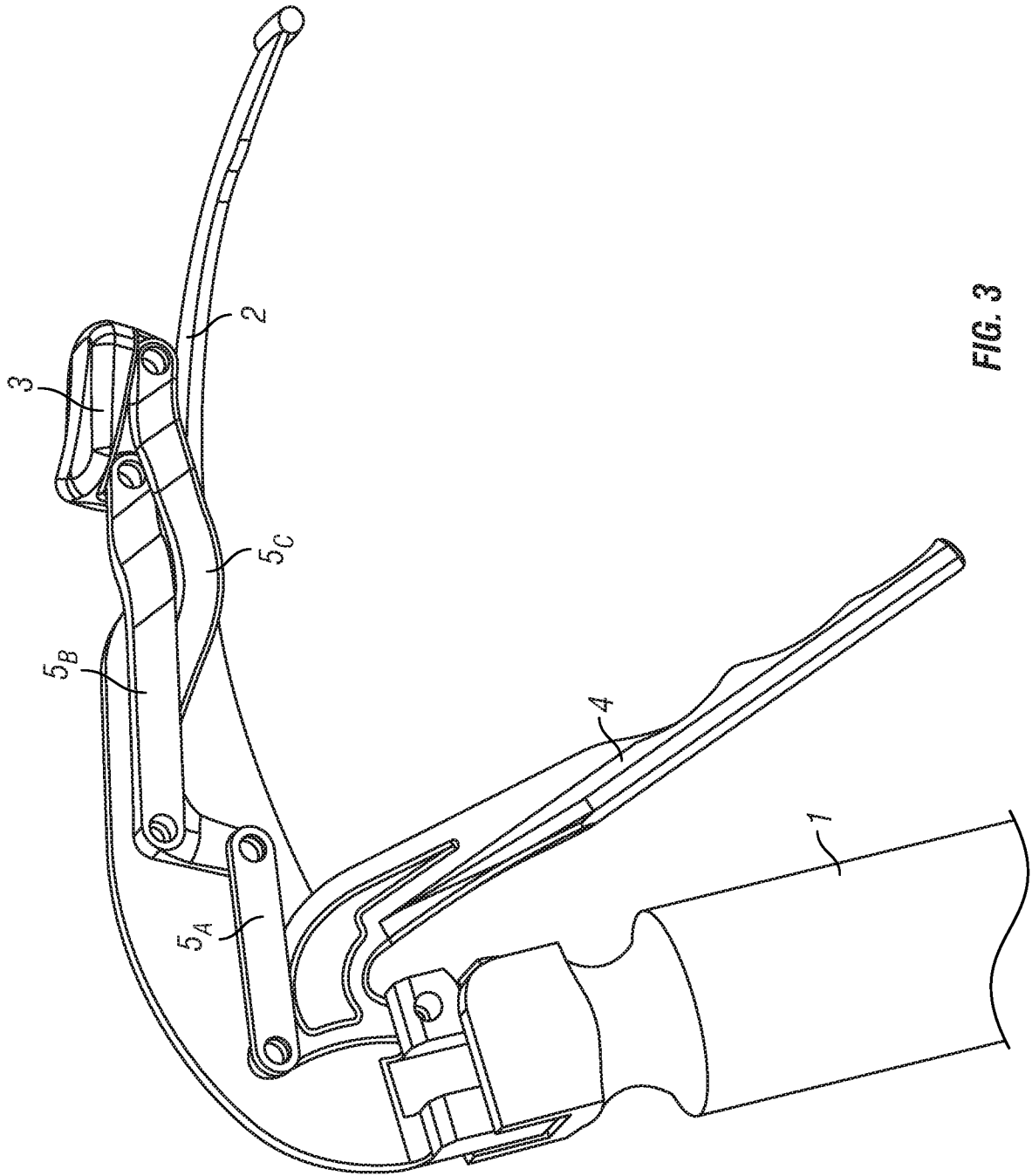

FIG. 3

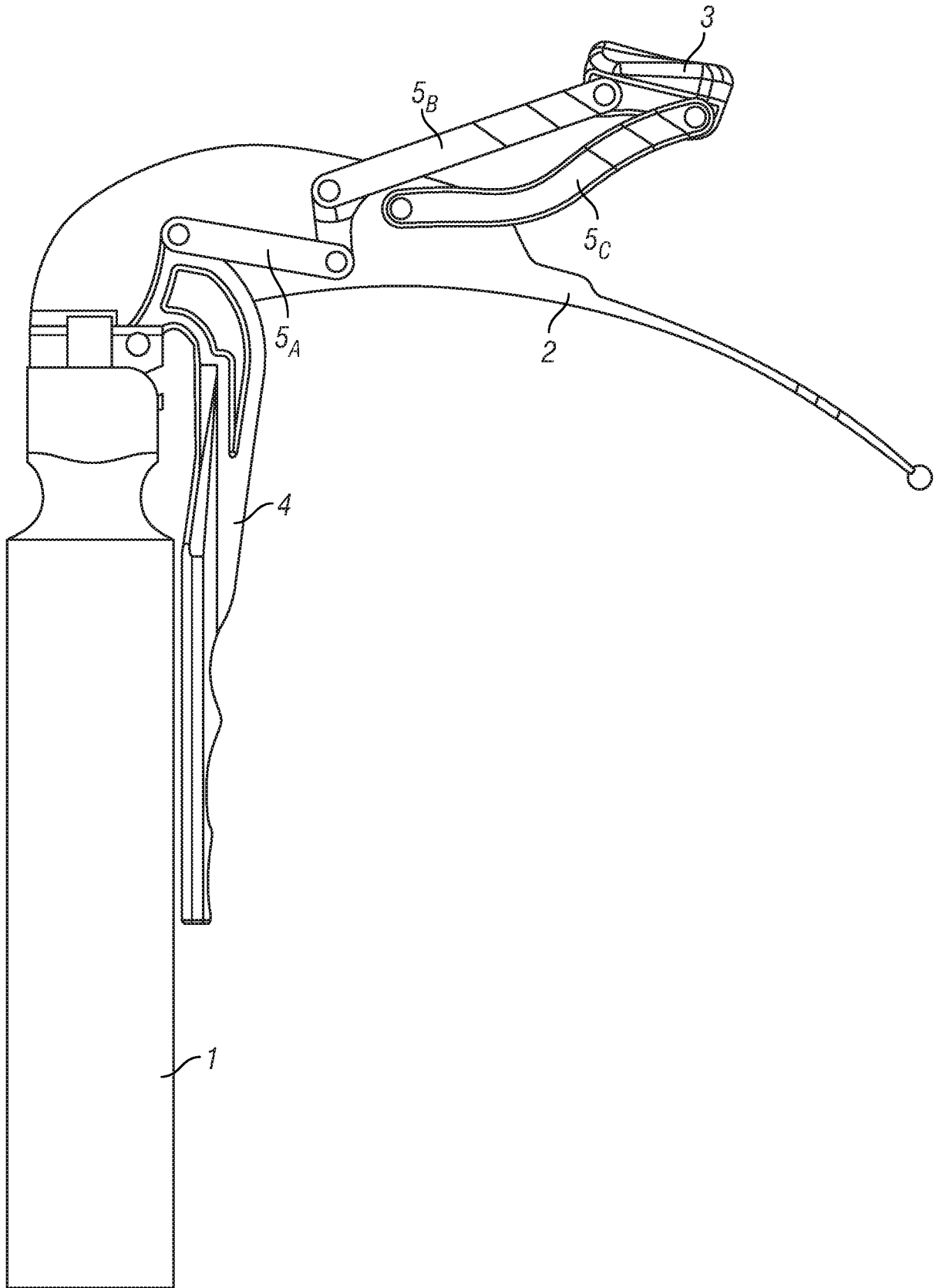

FIG. 4

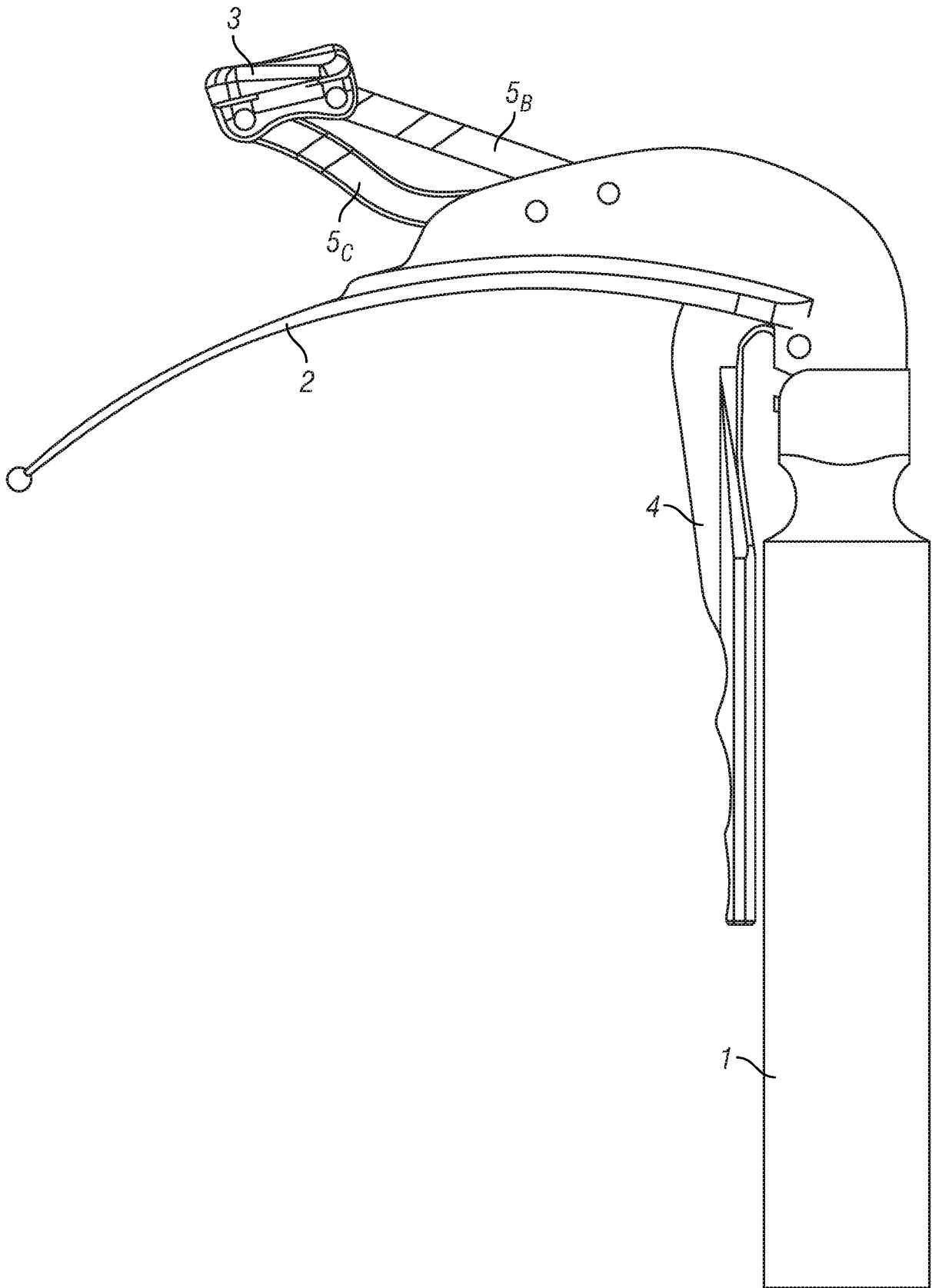

FIG. 5

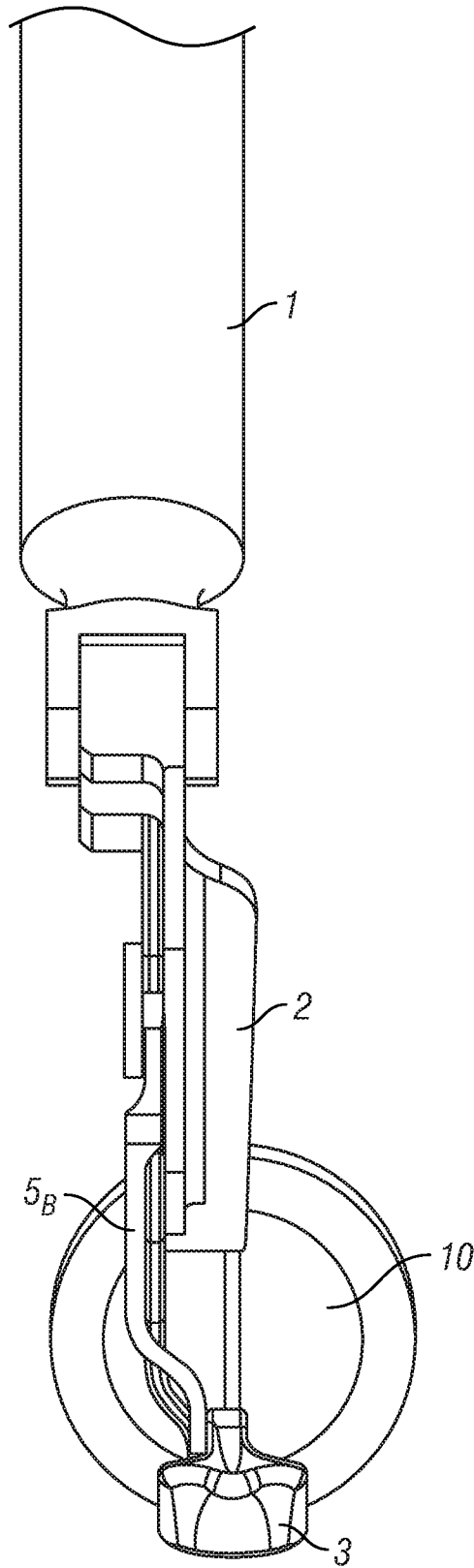

FIG. 6

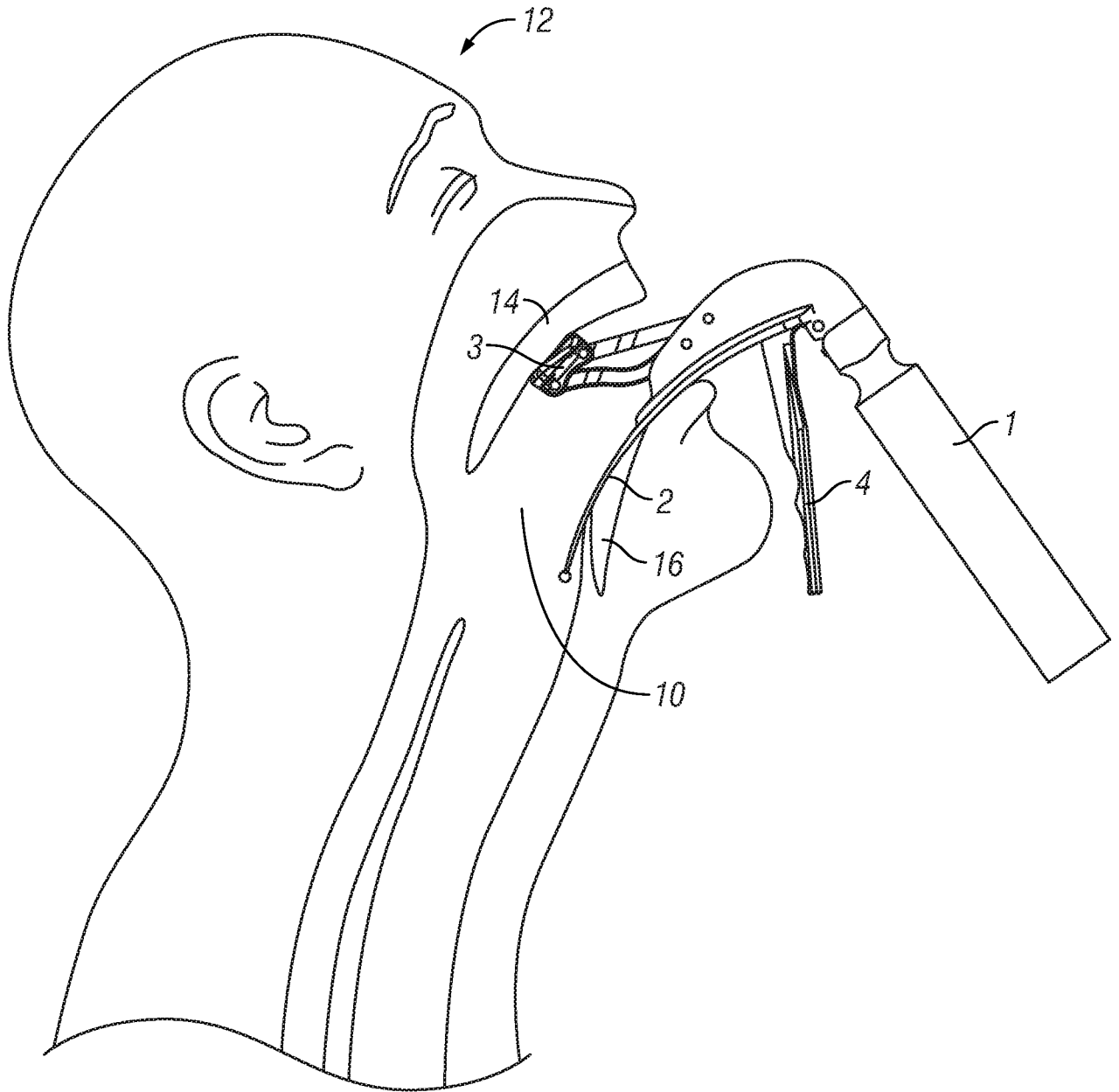

FIG. 7

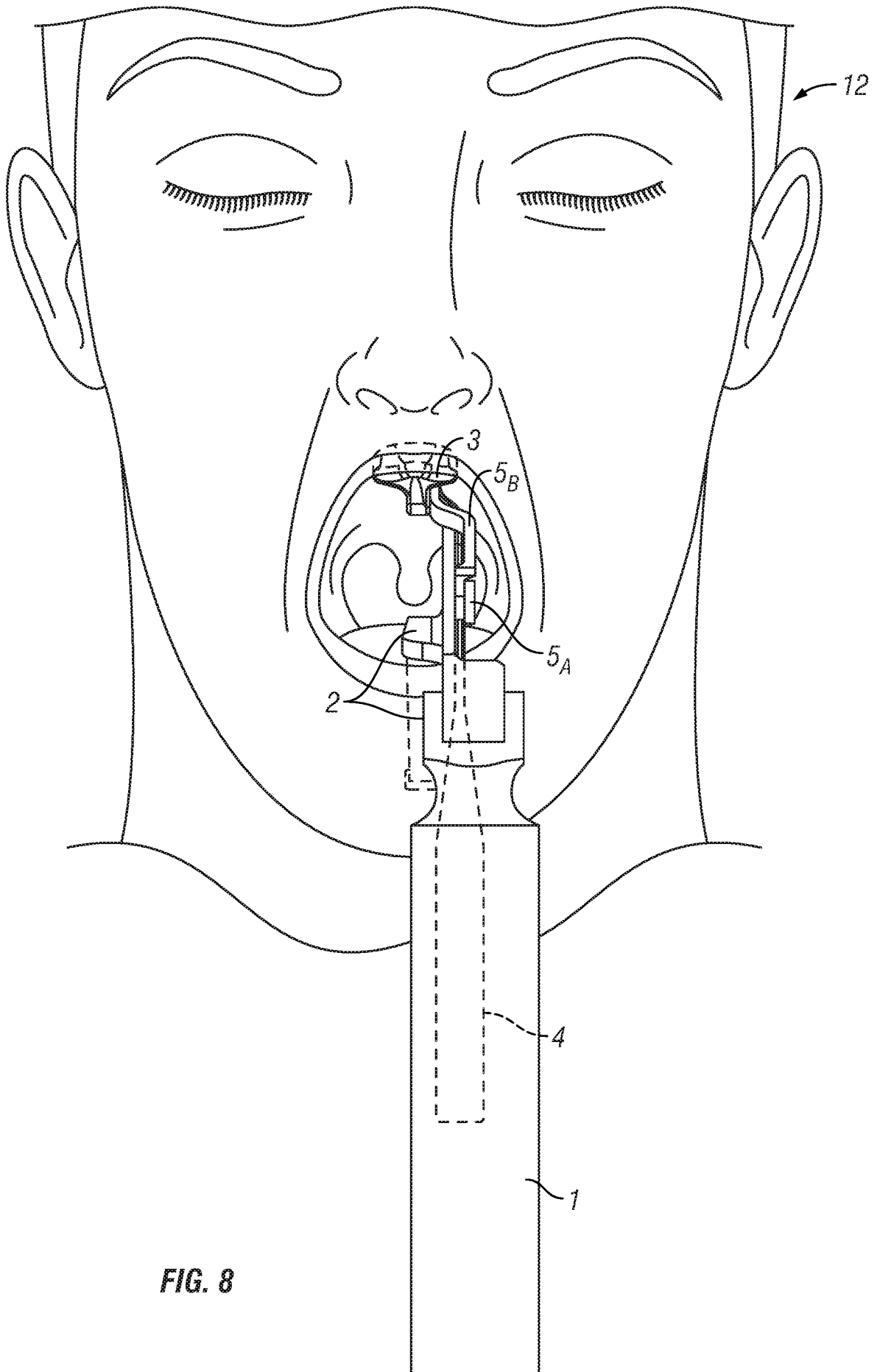

FIG. 8

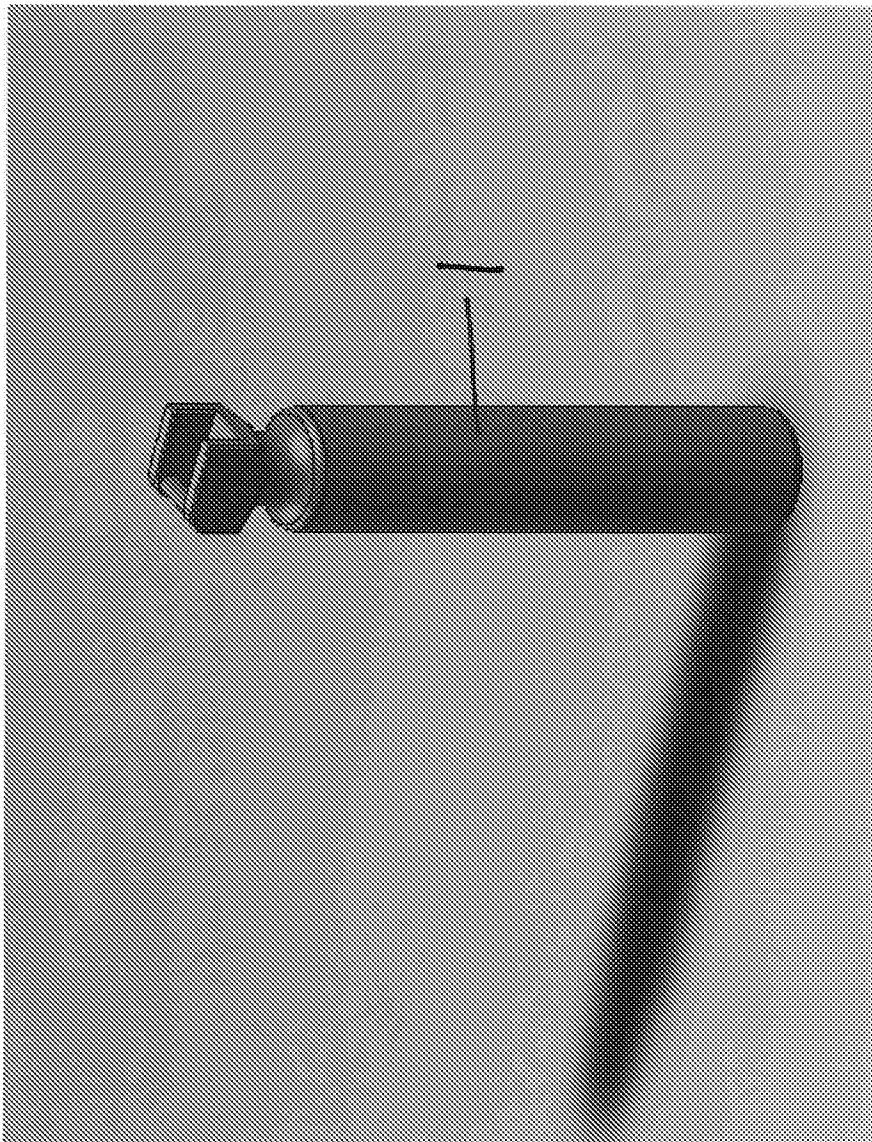

FIG. 9

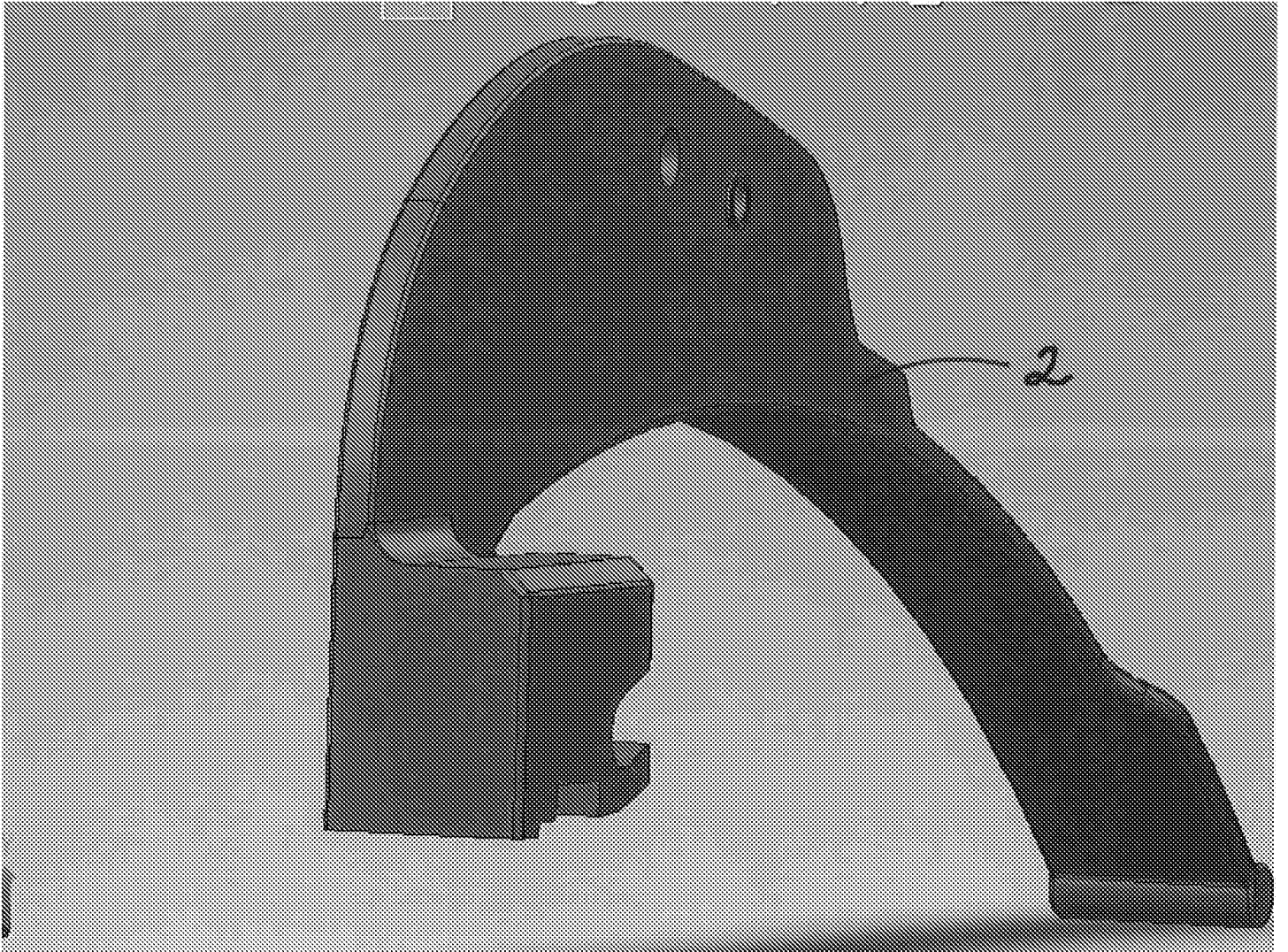

FIG. 10

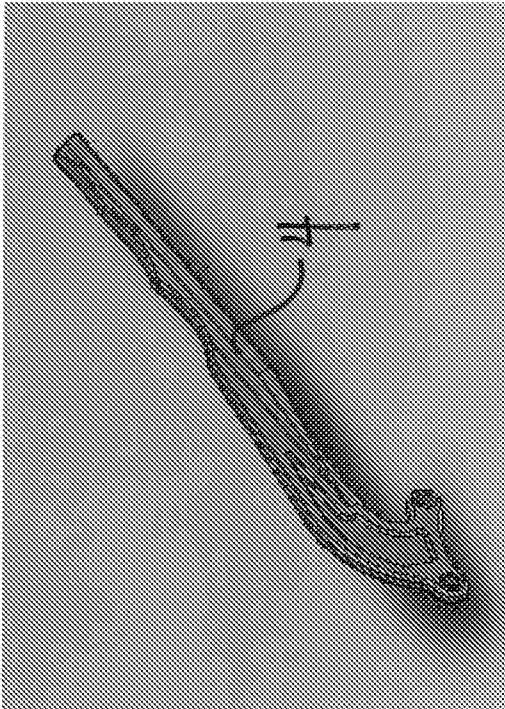

FIG. 11

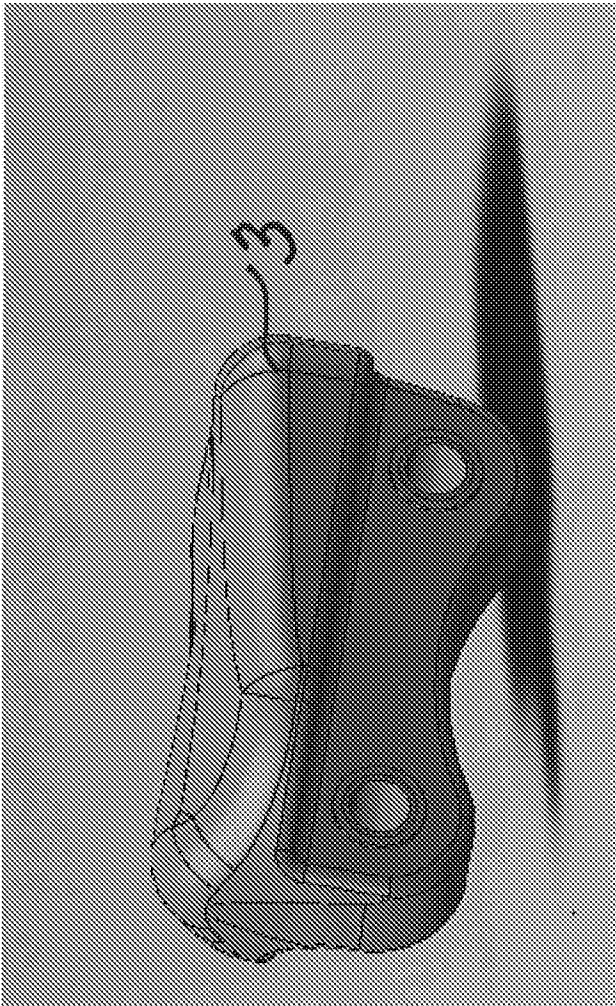

FIG.12

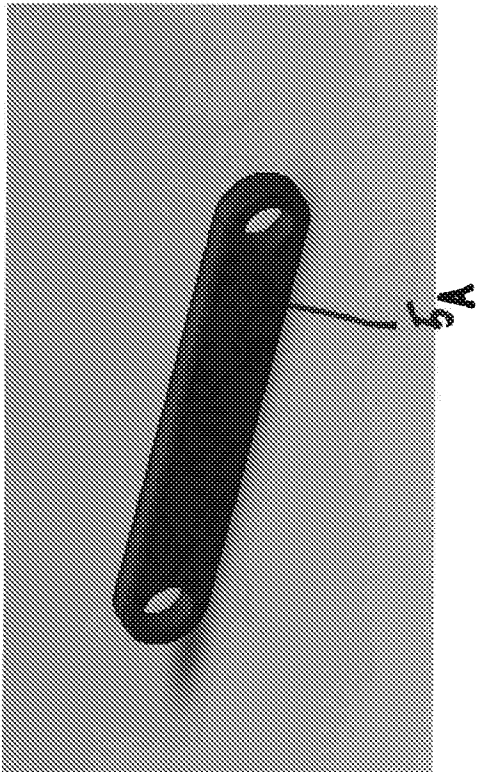

FIG. 13

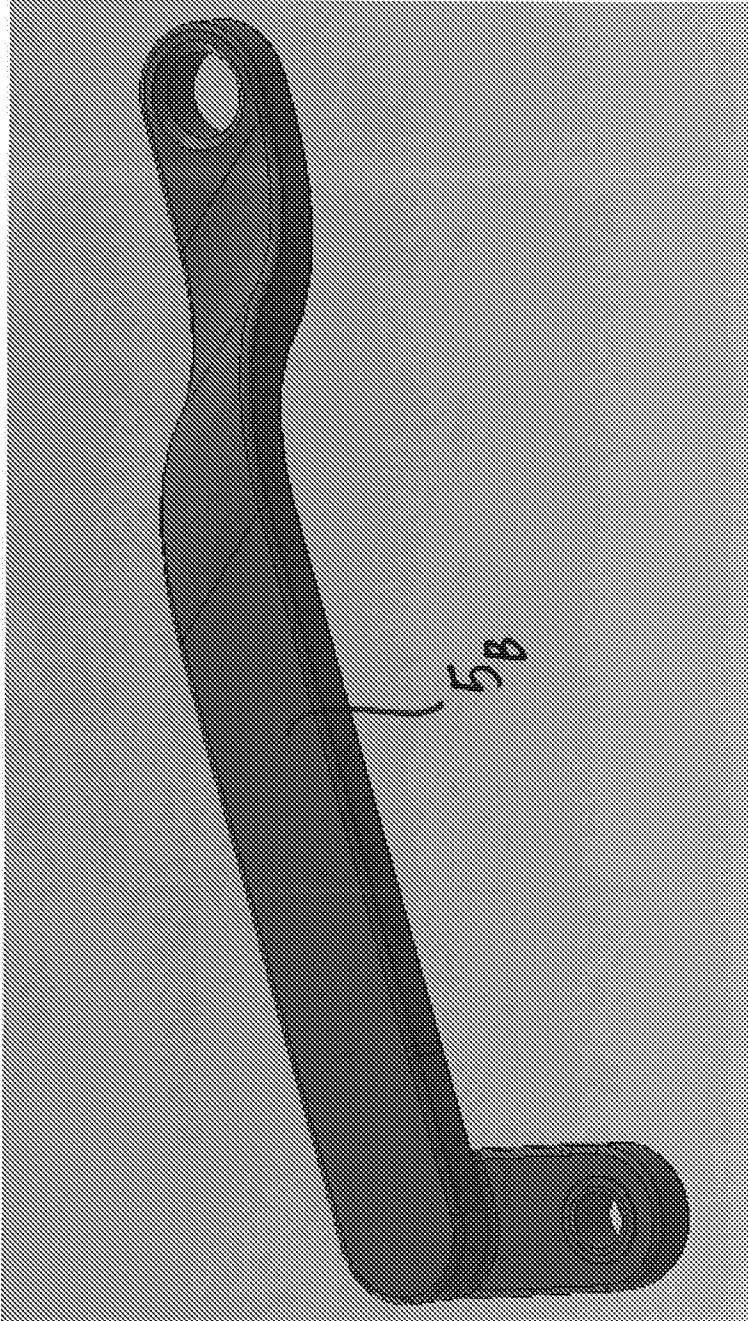

FIG. 14

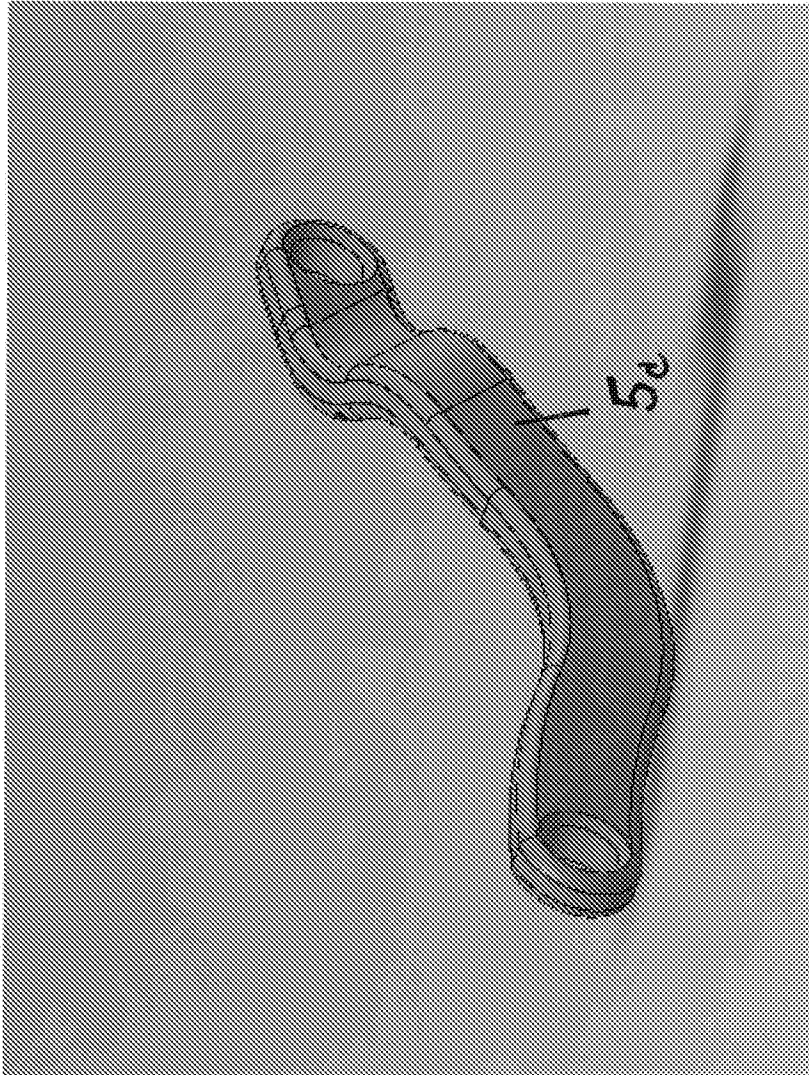

FIG. 15

A. CLASSIFICATION OF SUBJECT MATTER**A61B 1/24(2006.01)i, A61B 13/00(2006.01)i**

According to International Patent Classification (IPC) or to both national classification and IPC

B. FIELDS SEARCHEDMinimum documentation searched (classification system followed by classification symbols)
A61B 1/24; A61B 1/273; A61B 1/267; A61B 1/32; A61B 13/00Documentation searched other than minimum documentation to the extent that such documents are included in the fields searched
Korean utility models and applications for utility models
Japanese utility models and applications for utility modelsElectronic data base consulted during the international search (name of data base and, where practicable, search terms used)
eKOMPASS(KIPO internal) & Keywords: laryngoscope, palate, roof, mouth**C. DOCUMENTS CONSIDERED TO BE RELEVANT**

Category*	Citation of document, with indication, where appropriate, of the relevant passages	Relevant to claim No.
Y	JP 2012-196300 A (YAMASHITA MOTOKI) 18 October 2012 See paragraphs [27]-[38] and figures 1,8.	1
A		2,3
Y	KR 10-2010-0131111 A (CHUNG-ANG UNIVERSITY INDUSTRY-ACADEMY COOPERATION FOUNDATION) 15 December 2010 See paragraphs [21],[22] and figure 2.	1
A	US 8444556 B2 (MINSON) 21 May 2013 See column 5, line 29 - column 7, line 25 and figures 1-5B.	1-3
A	US 2006-0074276 A1 (CANTRELL) 06 April 2006 See paragraphs [19]-[39] and figures 1-5.	1-3
A	JP 08-510938 A (BRUMMERT, MANFRED) 19 November 1996 See claims 1-8 and figures 1-3.	1-3

 Further documents are listed in the continuation of Box C. See patent family annex.

* Special categories of cited documents:

"A" document defining the general state of the art which is not considered to be of particular relevance

"E" earlier application or patent but published on or after the international filing date

"L" document which may throw doubts on priority claim(s) or which is cited to establish the publication date of another citation or other special reason (as specified)

"O" document referring to an oral disclosure, use, exhibition or other means

"P" document published prior to the international filing date but later than the priority date claimed

"T" later document published after the international filing date or priority date and not in conflict with the application but cited to understand the principle or theory underlying the invention

"X" document of particular relevance; the claimed invention cannot be considered novel or cannot be considered to involve an inventive step when the document is taken alone

"Y" document of particular relevance; the claimed invention cannot be considered to involve an inventive step when the document is combined with one or more other such documents, such combination being obvious to a person skilled in the art

"&" document member of the same patent family

Date of the actual completion of the international search

14 June 2017 (14.06.2017)

Date of mailing of the international search report

14 June 2017 (14.06.2017)

Name and mailing address of the ISA/KR

International Application Division
Korean Intellectual Property Office
189 Cheongsa-ro, Seo-gu, Daejeon, 35208, Republic of Korea

Facsimile No. +82-42-481-8578

Authorized officer

KIM, Yeon Kyung

Telephone No. +82-42-481-3325



INTERNATIONAL SEARCH REPORT

Information on patent family members

International application No.

PCT/US2016/069324

Patent document cited in search report	Publication date	Patent family member(s)	Publication date
JP 2012-196300 A	18/10/2012	JP 5285732 B2	11/09/2013
KR 10-2010-0131111 A	15/12/2010	KR 10-1082806 B1	11/11/2011
US 8444556 B2	21/05/2013	US 2008-0167530 A1 US 2012-0130176 A1 US 8083672 B2	10/07/2008 24/05/2012 27/12/2011
US 2006-0074276 A1	06/04/2006	AU 2004-270208 A1 CA 2537979 A1 EP 1670351 A2 JP 2007-503931 A JP 4557977 B2 US 2005-0054903 A1 US 6991604 B2 US 7500948 B2 WO 2005-023332 A2 WO 2005-023332 A3	17/03/2005 17/03/2005 21/06/2006 01/03/2007 06/10/2010 10/03/2005 31/01/2006 10/03/2009 17/03/2005 21/07/2005
JP 08-510938 A	19/11/1996	CA 2164224 A1 DE 4335347 A1 DE 4335347 C2 EP 0703749 A1 WO 94-28785 A1	22/12/1994 22/12/1994 10/07/1997 14/05/1997 22/12/1994