

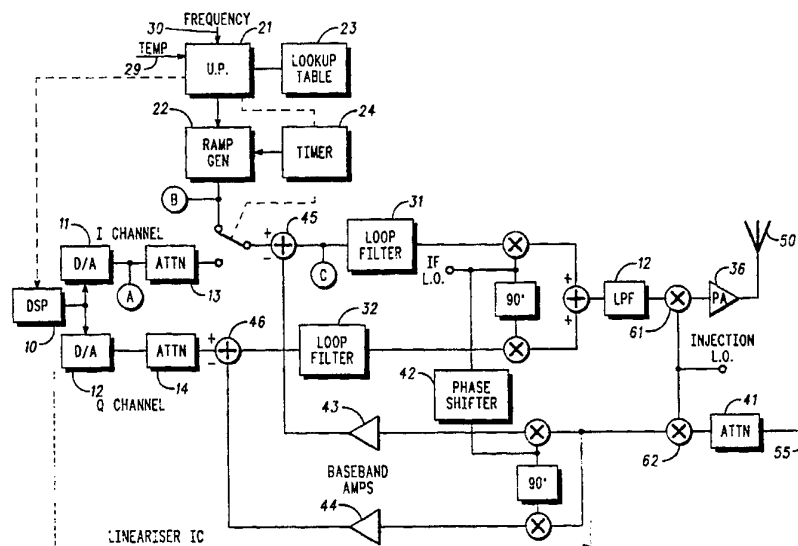

## INTERNATIONAL APPLICATION PUBLISHED UNDER THE PATENT COOPERATION TREATY (PCT)

(51) International Patent Classification <sup>6</sup> : <b>H03F 1/32, H03G 3/20</b>	<b>A1</b>	(11) International Publication Number: <b>WO 95/06354</b> (43) International Publication Date: <b>2 March 1995 (02.03.95)</b>
<p>(21) International Application Number: <b>PCT/IB94/00301</b></p> <p>(22) International Filing Date: <b>11 August 1994 (11.08.94)</b></p> <p>(30) Priority Data: 9317316.9            20 August 1993 (20.08.93)    GB 9318694.8            9 September 1993 (09.09.93)    GB</p> <p>(71) Applicant (for all designated States except US): <b>MOTOROLA, INC. [US/US]; 1303 East Algonquin Road, Schaumburg, IL 60196 (US).</b></p> <p>(72) Inventors; and (75) Inventors/Applicants (for US only): <b>HOROWITZ, Ilan [IL/IL]; 113 Habanim Street, Nes-Ziona (IL). BEN AYUN, Moshe [IL/IL]; 11 Htchiya, Holon (IL). SHAMSIAN, Roni [IL/IL]; 5/9 Moshe Sharet, Holon (IL). GRABSKY, Nachman [IL/IL]; Yosefi 12, Ramat Gan (IL). ROZENTAL, Mark [IL/IL]; 29 Herzel Street, 76560 Rehovot (IL).</b></p> <p>(74) Common Representative: <b>MOTOROLA, INC.; c/o H.C. Dunlop, Motorola European Intellectual Property Operations, Midpoint, Alencon Link, Basingstoke, Hants RG21 1PL (GB).</b></p>	<p>(81) Designated States: <b>CN, JP, US, European patent (AT, BE, CH, DE, DK, ES, FR, GB, GR, IE, IT, LU, MC, NL, PT, SE).</b></p> <p><b>Published</b> <i>With international search report. Before the expiration of the time limit for amending the claims and to be republished in the event of the receipt of amendments.</i></p>	

## (54) Title: RADIO TRANSMITTER WITH POWER AMPLIFIER LINEARIZER



## (57) Abstract

This invention relates to a radio transmitter having a power amplifier and a linearizer arrangement, for example Cartesian feedback, for compensating for non-linearity in the power amplifier. A training signal is applied to the amplifier (36) and the linearizer arrangement is adjusted during a training mode of operation. In one embodiment, a look-up table (23) is provided for storing predetermined operating condition adjustment parameters. According to an operating condition input (e.g. frequency, temperature) control means (21) select operating condition adjustment parameters during the training mode and adjust the training signal to compensate for loop gain variations during the training mode. Automatic gain control (26) may be provided in the amplifier loop for activation during at least a portion of the training mode of operation to maintain constant closed loop gain.

**FOR THE PURPOSES OF INFORMATION ONLY**

Codes used to identify States party to the PCT on the front pages of pamphlets publishing international applications under the PCT.

AT	Austria	GB	United Kingdom	MR	Mauritania
AU	Australia	GE	Georgia	MW	Malawi
BB	Barbados	GN	Guinea	NE	Niger
BE	Belgium	GR	Greece	NL	Netherlands
BF	Burkina Faso	HU	Hungary	NO	Norway
BG	Bulgaria	IE	Ireland	NZ	New Zealand
BJ	Benin	IT	Italy	PL	Poland
BR	Brazil	JP	Japan	PT	Portugal
BY	Belarus	KE	Kenya	RO	Romania
CA	Canada	KG	Kyrgystan	RU	Russian Federation
CF	Central African Republic	KP	Democratic People's Republic of Korea	SD	Sudan
CG	Congo	KR	Republic of Korea	SE	Sweden
CH	Switzerland	KZ	Kazakhstan	SI	Slovenia
CI	Côte d'Ivoire	LI	Liechtenstein	SK	Slovakia
CM	Cameroon	LK	Sri Lanka	SN	Senegal
CN	China	LU	Luxembourg	TD	Chad
CS	Czechoslovakia	LV	Larvia	TG	Togo
CZ	Czech Republic	MC	Monaco	TJ	Tajikistan
DE	Germany	MD	Republic of Moldova	TT	Trinidad and Tobago
DK	Denmark	MG	Madagascar	UA	Ukraine
ES	Spain	ML	Mali	US	United States of America
FI	Finland	MN	Mongolia	UZ	Uzbekistan
FR	France			VN	Viet Nam
GA	Gabon				

## RADIO TRANSMITTER WITH POWER AMPLIFIER LINEARIZER

Field of the Invention

5

This invention relates to a radio transmitter having a power amplifier and a linearizer arrangement for compensating for non-linearity in the power amplifier. An example of such an arrangement is Cartesian feedback with training.

10

Background to the Invention

Linear transmitters use closed loop techniques to achieve high linearity. The Cartesian feedback loop is a closed loop that includes a nonlinear RF power amplifier (PA). The PA's linearity performance improves proportionally to the loop gain in which the PA is located.

Stability has to be ensured before closing the loop to avoid oscillators and splatter. One method that is used is applying a training signal to the open loop and using a unique method to adjust the loop's phase to be 180 degrees at the summing junction to ensure stability - (see WO-A-9208280).

A RF power amplifier tends to change its phase shift versus output power. Such a PA's AM to PM response reduces the effective phase margin of the loop. The phase adjust should be done at an input level which drives the PA to approximately average output power to maintain a correct phase. Incorrect phase adjust will reduce the effective phase margin and can cause oscillations to occur at peak output power where the PA adds its maximum phase shift.

Forward path gain variations (radio to radio variations, temperature variations and frequency variations) will result in different output powers for the same input level so the phase training will result in incorrect phase adjustment. Moreover, the gain variation that will increase the phase training output power will increase splatter.

In order to maintain the required linearity and good efficiency it is necessary to tune the drive level to be below clip. A method that is used is a training ramp at the baseband input that increases the input until clip is detected by comparing the loop error to a level that indicates clip. The

35

ramp's input level is sampled at the time that clip is detected and the data input level is adjusted to be below clip.

The accuracy of the clip detection by this method and splatter caused while clip is detected depends on the error level before clip. This error level is proportional to loop gain so loop gain variations (typically 10-15 dB vs. temperature and frequency) will influence the detected clip point and splatter.

The problems with known techniques are: (1) additional splatter due to training; (2) over design safety margin:- phase margin and clip to peak power over head ratio.

GB-A-2265270 of Motorola Ltd, published on 22nd September 1993, describes an arrangement which seeks to avoid amplifier training by providing a *priori* adjustment factors to adjust the loop as far as possible to match the operating conditions, using temperature and frequency look-up tables.

#### Summary of the Invention

According to the a first aspect of the present invention, a radio transmitter is provided comprising: a power amplifier; linearizer means coupled to the amplifier for compensating for non-linearity in the power amplifier; feedback means for feeding a signal from an output of the power amplifier to the linearizing means, whereby said amplifier, feedback means and linearizer means form an amplifier loop having a varying loop gain, and training means for applying a training signal to the amplifier and adjusting the linearizer means during a training mode of operation. The arrangement is characterized by: a look-up table for storing predetermined operating condition adjustment parameters and control means having an operating condition input, said control means being coupled to the look-up table for selecting operating condition adjustment parameters according to the operating condition input during the training mode and adjusting the training signal to compensate for loop gain variations during the training mode.

In this manner, more accurate and consistent training can be achieved for varying operating conditions (e.g. temperature and frequency).

The training means preferably comprise switching means for opening and closing the amplifier loop and means for applying a phase training signal to the amplifier when the loop is open, wherein the control means adjust the phase training signal to adjust for open loop gain variations. In this manner, the phase training signal can be adjusted to perform phase training at, for example, a consistent predetermined output power level (e.g. average output power) irrespective of the open loop gain at the operating conditions.

A temperature sensor may be provided and the look-up table may comprise temperature adjustment parameters.

Alternatively or in addition, the operating condition input may comprise a frequency selection input and the look-up table may comprise frequency adjustment parameters, with the control means being responsive to the frequency selection input to select one or more frequency adjustment parameters and to adjust the phase training signal according to the one or more frequency adjustment parameters.

In accordance with a second aspect of the invention, a radio transmitter is provided comprising a power amplifier, linearizer means coupled to the amplifier for compensating for non-linearity in the power amplifier, feedback means for feeding a signal from an output of the power amplifier to the linearizer means, whereby the amplifier, feedback means and linearizer means form an amplifier loop having a varying loop gain, and training means for applying a training signal to the amplifier and adjusting the linearizer means during a training mode of operation. The invention is characterised by automatic gain control means in the amplifier loop and control means for activating the automatic gain control means during at least a portion of the training mode of operation to maintain constant closed loop gain during that portion and to deactivate the automatic gain control means during a transmit mode of operation.

In a particularly preferred further aspect of the invention, the training means comprise means for applying a gain training signal to the amplifier, wherein the control means adjust the gain training signal.

This feature has the advantage of enabling consistent gain training, for example from a consistent starting level to a consistent clip point. By achieving a consistent clip point, at least two advantages are derived. The

amplifier can be designed to be backed off from the clip point by a smaller safety margin, thereby enabling greater efficiency. During amplitude training itself, splatter is unavoidably generated, but the situation can be avoided where the level before clip results in an unnecessarily high clip point and causes excessive splatter.

It is preferably the slope of a portion of linearly increasing amplitude of the gain training signal that is adjusted.

A preferred embodiment of the invention is now described, by way of example only, with reference to the drawings.

10

### Brief Description of the Drawings

Fig. 1 illustrates a typical training signal.

Fig. 2 is a block diagram of a Cartesian feedback loop according to a first embodiment of the invention.

Fig. 3 is a graph showing forward gain vs. temperature for a typical amplifier.

Fig. 4 is a graph showing forward gain vs. frequency for a typical amplifier.

Fig. 5 illustrates the error signal at the amplifier training stage.

Fig. 6 is a graph showing loop gain vs. temperature for a typical amplifier.

Fig. 7 is a block diagram of a Cartesian feedback loop according to a second embodiment of the invention.

25

### Detailed Description

Fig. 1 shows a training signal that is applied to the input of a Cartesian feedback loop. The training starts with one period of sine wave that is used to adjust the phase. This sine wave is applied to the open loop and the total loop's phase is measured at the feedback input to the summing junction and then adjusted. After the phase has been adjusted the loop is closed at the time point marked by Tx. The second stage of the training is clip detection. A ramp generator is now connected to the input.

The input power increases linearly driving the PA towards maximum output power. When the PA starts compressing the error voltage rises and

when it reaches the threshold level clip is indicated. The maximum data input level is 2-3 dB below clip level.

Fig. 2 shows a block diagram of a Cartesian feedback transmitter in accordance with the invention. The radio transmitter comprises a DSP (digital signal processor) 10, a D/A (digital to analog converter) for I channel 11, a D/A for Q channel 12, input attenuation for I channel 13, input attenuation for Q channel 14, a loop filter for I channel 31, a loop filter for Q channel 32, a low pass filter 35, an up converter 61, a power amplifier 36 and an antenna 50. The power amplifier 36 output signal is sampled by the coupler 55 and attenuated by the feedback attenuator 41. The feedback attenuator 41 is connected to a down converter 62 then splits into I and Q and the signal goes to the baseband amplifier for the I channel 43 and to the baseband amplifier for the Q channel 44, closing the loop. The loop has also a microprocessor 21 which senses the temperature via line 29 and updates transmission parameters from a look-up table 23. The microprocessor has a frequency selection input 30 for selecting a desired frequency (e.g. a channel selector). The frequency selection input may be derived in other ways by the microprocessor itself. The microprocessor 21 also controls a ramp generator 22 and a timer 24.

The transmitter is trained before transmitting data. The first step is phase training to adjust the loop's phase to be -180 degrees at the summing junction 45, 46. The loop is then closed and the amplitude training detects the clip point of the power amplifier 36. The data level is adjusted to be 2-3 dB below clip.

On accepting a request for transmission the power amplifier 36 is turned on and the microprocessor sets the transmitter to transmit at open loop i.e. the feedback path is disabled. The microprocessor 21 updates the phase training signal's level from the look-up table 23 according to transmission frequency and temperature. The microprocessor 21 controls the phase training signal's level at the DSP 10. The DSP 10 generates one period of sine wave to the I channel and zero to the Q channel as shown in Fig. 1. The DSP's digital samples are converted to analog signal by the D/A 13 and this passes along the forward path through the power amplifier 36 to the antenna 50. While transmitting the phase training signal the phase around the loop is adjusted by a phase shifter 42 to be -180 deg. at the summing junction to ensure maximum phase margin.

After the loop is closed the microprocessor sets the timer 24 to connect the ramp generator 22 to the loop's input. The ramp generator 22 generates a ramp having a slope which has been updated by the microprocessor 21 according to transmission frequency and temperature.

5           The input ramp increases output power of the power amplifier 36 linearly. Before the power amplifier 36 comes into compression (starts clipping) the error level (point C) is constant and it is proportional to the loop gain and the ramp's slope. When the power amplifier 36 starts clipping, the error increases rapidly and when it crosses a threshold level  
10 this indicates clip and the ramp is sampled. The linearizer then adjusts the input attenuators (for I channel 13 and for Q channel 14) so that the DSP's maximum input level will be 2-3 dB below clip power. The fact that the ramp's slope is controlled by the microprocessor 21 results in an accurate clip detection which will allow lower the overhead ratio and will  
15 avoid additional splatter that is caused by the amplitude training.

After the training sequence, the timer 24 connects the input attenuator 13 to the loop's input and the transmitter is ready to transmit data. The microprocessor 21 controls the DSP 10 to start sending data to the transmitter.

20           Fig. 3 describes the average forward path's gain variations vs. temperature. This average curve is a result of radios measurements. The gain was measured by applying an input signal that results in average output power (or as close as possible) at all temperature points. A linear interpolation was done between the measured points.

25           Fig. 4 describes the average forward path's gain variations vs. frequency. This average curve is a result of radios measurements. The gain was measured by applying an input signal that results in average output power (or as close as possible) at all frequencies points. A linear interpolation was done between the measured points.

30           The following table can be used to adjust the input signal's level against temperature at the phase training stage:

temp	-30	-20	-10	0	10	20	30	40	50	60	70
CF-1	0.63	0.65	0.67	0.71	0.77	0.88	1.00	1.18	1.33	1.58	1.67

\*Temperature in deg C



\*C.F. is a correction factor

\*Linear interpolation between points

5 The following table can be used to adjust the input signal's level against frequency at the phase training stage:

freq.	806	809	812	815	818	821	824
CF-2	0.88	0.93	0.95	1.00	1.07	1.12	1.17

\*Frequency in MHz

\*C.F. is a correction factor

10 \*Linear interpolation between points

The phase training signal's amplitude for a unique radio at unique conditions is calculated as follows.

15 A factory adjustment is made of phase training input level required to result in average output power for the radio in question at nominal conditions (30°C, 815 MHz). An adjustment factor is stored in look-up table 23 e.g. in a non-volatile code plug. This tuning reduces radio-to-radio variations.

20 The unique adjustment factor is multiplied by CF-1 and by CF-2. The microprocessor 21 updates the DSP 10 with the resulting factor by which it's default phase training signal should be multiplied.

25 Fig. 5 illustrates the error signal (at point C in Fig. 2) during the amplitude training. After a transition response that takes 50-80 microseconds the error signal is stabilized and stays constant until clip occurs. The error level before clip is about 20-30 mV. This level is directly proportional to the ramp's slope and opposite to the loop gain. When the PA starts clipping the error increases rapidly. The exact clip point is detected by comparing the error level to threshold that represent clip (approx. 754 mV).

30 Fig. 6 shows loop gain variations vs. temperature. It shows upper and lower limits. All radios will be between these lines. The curves are relative to 30 deg. C since the radios are tuned in the factory at 30 deg. C. The curves have been derived empirically.

The following table can be used to change the ramp's slope against temperature during amplitude training:

temp	-30	-20	-10	0	10	20	30	40	50	60	70
Kr	2.31	2.00	1.77	1.58	1.41	1.26	1.00	0.79	0.71	0.63	0.56

5 Temperature is in degrees Centigrade. Kr is a correction factor. Linear interpolation is carried out between points.

The ramp's slope for a unique radio at unique condition is calculated by multiplying the radio's unique tuning factors (previously obtained by the ramp's slope calibration process) by Kr. The microprocessor 21 updates  
 1 0 the ramp generator 22 with the slope appropriate to the operating temperature.

In summary a method has been described for accurate and consistent amplifier training. The method comprises three major steps:  
 1 5 (1) factory adjustment of the phase training input level to result in average output power for each radio at nominal conditions, the adjustment result being stored in the radio's code plug. This tuning will reduce radio to radio variations; (2) adjustment of open loop gain during phase training according to pre-stored operating condition adjustment factors and (3)  
 2 0 adjustment of closed loop gain during amplitude training according to pre-stored operating condition adjustment factors.

The second step involves a two-part procedure. Firstly, the radio's forward path gain variations vs. temperature (Fig. 3) are characterized and a look-up table is created to change the phase training signal's level vs. temperature every 10 deg C. The look-up table can also be based on  
 2 5 predetermined factors and/or equations and/or a characterizing equation.

Secondly, the radio's forward path gain variations vs. frequency (Fig. 4) are characterized and a look-up table is created to change the phase training signal's level vs. frequency at five different frequencies. Again the look-up table can be based on predetermined factors and/or equations  
 3 0 and/or a characterizing equation.

Linear interpolation is carried out between the characterized points in each case.

This method will reduce 15-20 dB of forward gain variations to 3-4 dB variations maintaining correct phase adjust, maximum phase margin and reduce additional splatter.

5 The third step involves changing the ramp's slope relative to loop gain in order to minimize error voltage variations caused by loop gain variations. The procedure will improve clip detection accuracy and will reduce splatter. The third step uses a modified amplitude training signal that changes the ramp's slope in proportion to loop gain to maintain constant error level before clip.

10 By way of explanation of the observation that ramp slope, loop gain and error are proportionally related, the following mathematical analysis in Laplace plane is given (referring to Fig. 2).

$$AB(s) = ab/s \quad (\text{before clip}); \text{ ab is the loop gain}$$

15

and the input is a ramp that is modelled by (at point B):

$$V_{\text{input}}(s) = K/s^2 \quad K \text{ is the ramp's slope}$$

20 The error voltage will be then (at point C);

$$V_{\text{error}} = V_{\text{input}} * 1/(1+AB) \quad V_{\text{input}}/(AB) \text{ when } AB \gg 1$$

Assigning  $AB=ab/s$  and  $V_{\text{input}}=k/s^2$  will give:

25

$$V_{\text{error}} \sim k/ab * 1/s \quad (\text{before clip})$$

30 We can see that the error (at point C) will step up and it's level will be directly proportional to the ramp's slope (k) and opposite to the loop gain (ab).

The third step comprises two elements:

35 Firstly the radio's loop gain variations vs. temperature (Fig. 6) are characterised and a look-up table is created to change the ramp's slope vs. Temperature every 10 deg C. The look-up table can also be based on predetermined factors and/or equations and/or a characterizing equation. Linear interpolation is performed between the characterized points.

Secondly the loop gain variations vs. frequency are characterized and a look-up table is created to change the phase training signal's level vs. frequency at five frequencies.

5 The look-up table can also be based on predetermined factors and/or equations and/or a characterizing equation. It is also possible to do the tuning procedure in the factory at five r.f. frequencies and to store the five tuning results in the radio's code plug.

Linear interpolation is again performed between the characterized points.

10 This algorithm will reduce 10-15 dB of loop gain variations to 4 dB variation at the error signal maintaining accurate clip detection and reduce additional splatter.

Referring to Fig. 7, a further embodiment of the invention is shown. In this figure, elements already described with reference to  
15 Fig. 2 have the same reference numerals. Fig. 7 shows a block diagram of a Cartesian feedback transmitter similar to that of Fig. 2 but modified so as to include AGC circuitry. The timer 24 controls an AGC block 25 which senses the error voltage and controls the loop attenuators (for I & Q channels 33 & 34). The AGC block 25 contains  
20 the dynamics to control the AGC loop.

The transmitter is trained as described with reference to the circuit of Fig. 2 and after the loop is closed the microprocessor sets the timer 24 to connect the ramp generator 22 to the loop's input.

25 While the input starts ramping the error steps up and it settles after a settling time of 50-80 microseconds as shown in Fig. 5. After 100-150 microseconds, the AGC circuitry is activated to adjust the error level to be 25 mV by changing the loop attenuators 33 & 34. The attenuators should be set within 150-200 microseconds and then frozen until the next training. The attenuations of the loop attenuators 33 &  
30 34 are again updated at the next training period.

The input ramp increases output power of the power amplifier 36. When the power amplifier 36 starts clipping the error increases rapidly and when it crosses the threshold level that indicates clip, the ramp is sampled. The linearizer then adjusts the input attenuators  
35 (for I channel 13 and for Q channel 14) so that maximum input level of

the DSP 10 is 2-3 dB below the sampled level of the ramp. This ensures that the data's output power will be 2-3 dB below clip power.

5 The fact that the loop gain is adjusted before the clip is detected ensures an accurate clip detection which will allow lower overhead ratio (i.e. safety margin) and will avoid additional splatter that is caused by the amplitude training.

10 After the training sequence, the timer 24 connects the input attenuator 13 to the loop's input and the transmitter is ready to transmit data. The microprocessor 21 controls the DSP 10 to start sending data to the transmitter. The transmitter will operate at optimal stability conditions and the constant loop gain, achieved by the AGC operation, will result in constant adjacent splatter.

15 The AGC circuitry should be located at the forward path after the main noise source and before it degrades the forward path's linearity (Fig. 7). It should be able to maintain 20 dB of AGC (6 dB radio to radio variations, 3 dB flatness and 10 dB for temperature variations). The dynamics inside the AGC block 25 (zeros, poles and gain) are dependent on location of the attenuators 33 and 34 in the forward path.

20 The attenuation selected by the AGC will be activated at the phase training stage as well as at the transmitting time. Thus the AGC will keep the error level constant maintaining constant radio performance.

25 The arrangement makes use of the observation that the error signal is inversely proportional to the loop gain. This observation is used by the AGC circuit 26 to measure the error signal and adjust the attenuation in the loop to maintain constant and consistent loop gain.

Claims

1. A radio transmitter comprising;  
a power amplifier;  
5 linearizer means coupled to the amplifier for compensating for non-linearity in the power amplifier;  
feedback means for feeding a signal from an output of the power amplifier to the linearizing means, whereby said amplifier, feedback means and linearizer means form an amplifier loop having a varying loop  
10 gain,  
training means for applying a training signal to the amplifier and adjusting the linearizer means during a training mode of operation, characterized by:  
a look-up table for storing predetermined operating condition  
15 adjustment parameters and  
control means having an operating condition input, said control means being coupled to the look-up table for selecting operating condition adjustment parameters according to the operating condition input during the training mode and adjusting the training signal to compensate for loop  
20 gain variations during the training mode.
2. A transmitter according to claim 1, wherein the training means comprise switching means for opening and closing the amplifier loop and means for applying a phase training signal to the amplifier when the loop  
25 is open, wherein the control means adjust the phase training signal to adjust for open loop gain variations.
3. A transmitter according to claim 2, wherein the operating condition input comprises a temperature sensor, the look-up table comprises  
30 temperature adjustment parameters and the control means are responsive to the temperature sensor to select one or more temperature adjustment parameters and to adjust the phase training signal according to the one or more temperature adjustment parameters.
- 35 4. A transmitter according to claim 2 or 3, wherein the operating condition input comprises a frequency selection input, the look-up table

comprises frequency adjustment parameters and the control means are responsive to the frequency selection input to select one or more frequency adjustment parameters and to adjust the phase training signal according to the one or more frequency adjustment parameters.

5

5. A transmitter according to any one of the preceding claims, wherein the training means comprise means for applying a gain training signal to the amplifier, wherein the control means adjust the gain training signal.

10

6. A transmitter according to claim 5, wherein the gain training signal has a portion of linearly increasing amplitude and the control means adjust the slope of said portion.

15

7. A transmitter according to claim 6, wherein the operating condition input comprises a temperature sensor, the look-up table comprises temperature adjustment parameters and the control means are responsive to the temperature sensor to select one or more temperature adjustment parameters and to adjust the slope of said portion of the training signal according to the one or more temperature adjustment parameters.

20

8. A transmitter according to claim 6 or 7, wherein the operating condition input comprises a frequency selection input, the look-up table comprises frequency adjustment parameters and the control means are responsive to the frequency selection input to select one or more frequency adjustment parameters and to adjust the slope of said portion of the training signal according to the one or more frequency adjustment parameters.

25

9. A radio transmitter comprising;  
30 a power amplifier;  
linearizer means coupled to the amplifier for compensating for non-linearity in the power amplifier;  
feedback means for feeding a signal from an output of the power amplifier to the linearizer means, whereby said amplifier, feedback means  
35 and linearizer means form an amplifier loop having a varying loop gain,

training means for applying a training signal to the amplifier and adjusting the linearizer means during a training mode of operation, characterized by:

automatic gain control means in said amplifier loop and control  
5 means for activating said automatic gain control means during at least a portion of said training mode of operation to maintain constant closed loop gain during said portion and to deactivate said automatic gain control means during a transmit mode of operation.

10 10. A transmitter according to claim 9, wherein the training means comprise means for applying a gain training signal to the amplifier during a gain training portion of said training mode, wherein the control means are arranged to activate said automatic gain control means during said gain training portion.

15

11. A transmitter according to claim 10, wherein the gain training signal has a linear portion of linearly increasing amplitude and the control means are arranged to activate said automatic gain control means during said linear portion.

20



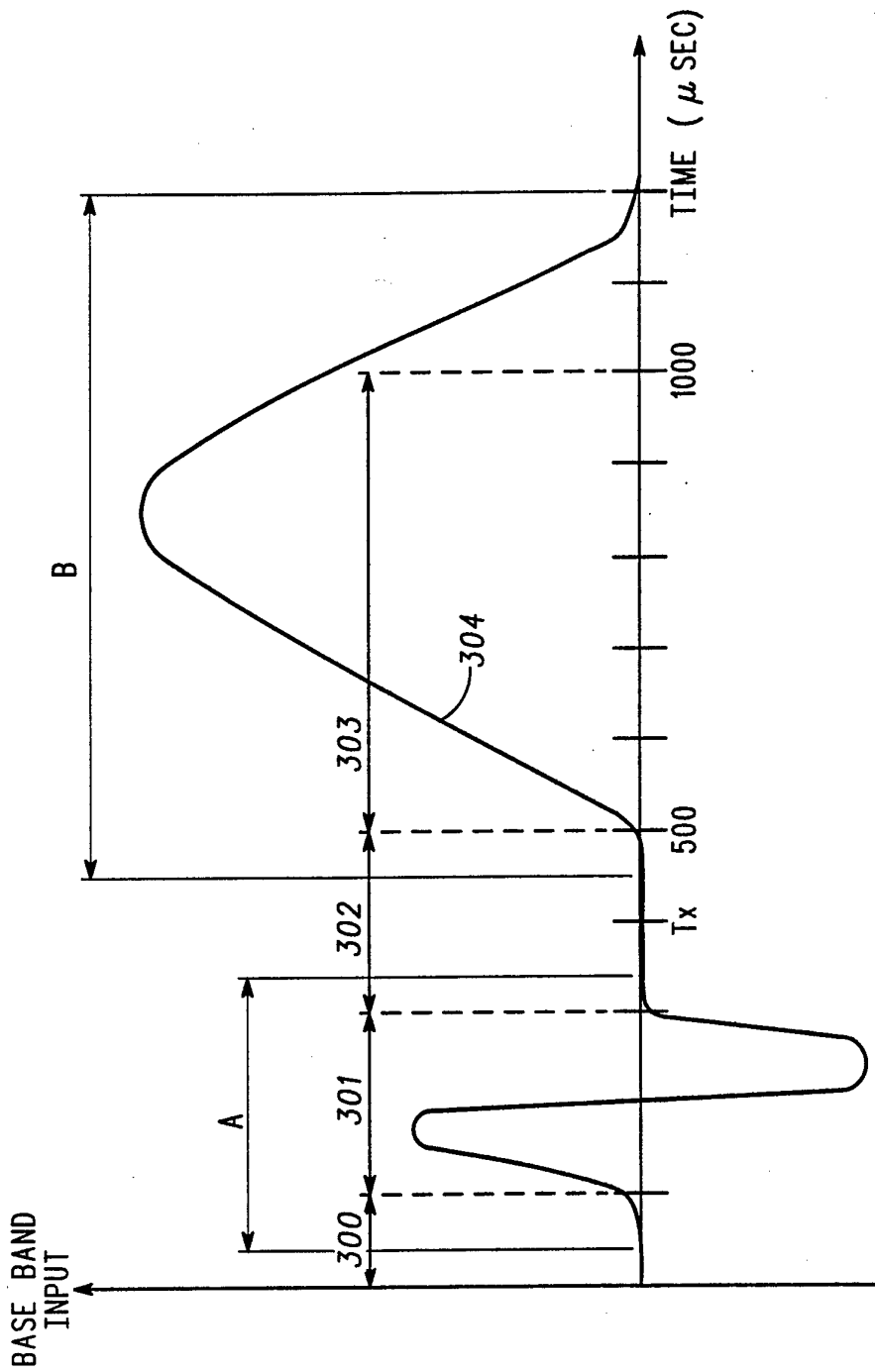

FIG. 1

—PRIOR ART—

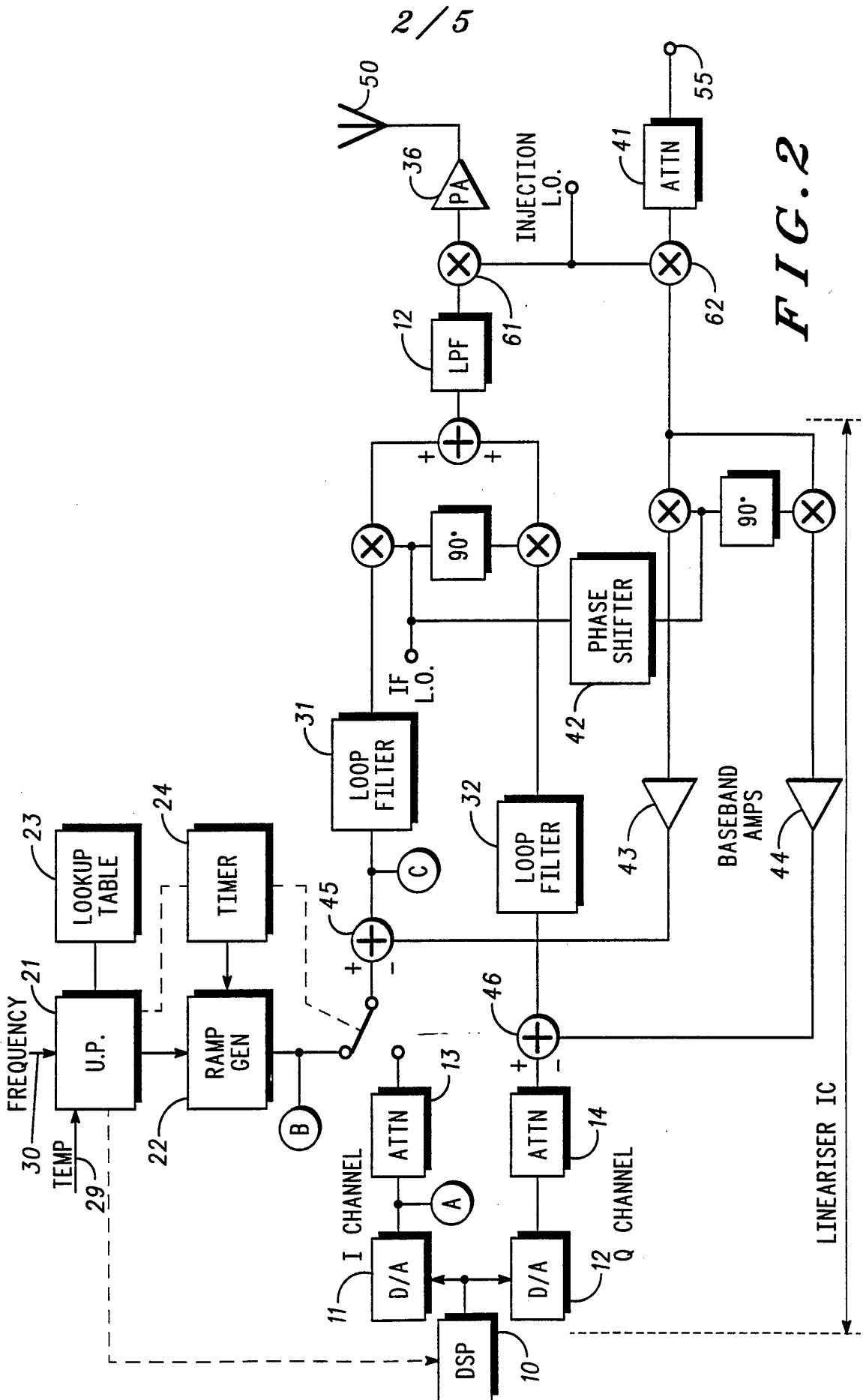

FIG. 2

3/5

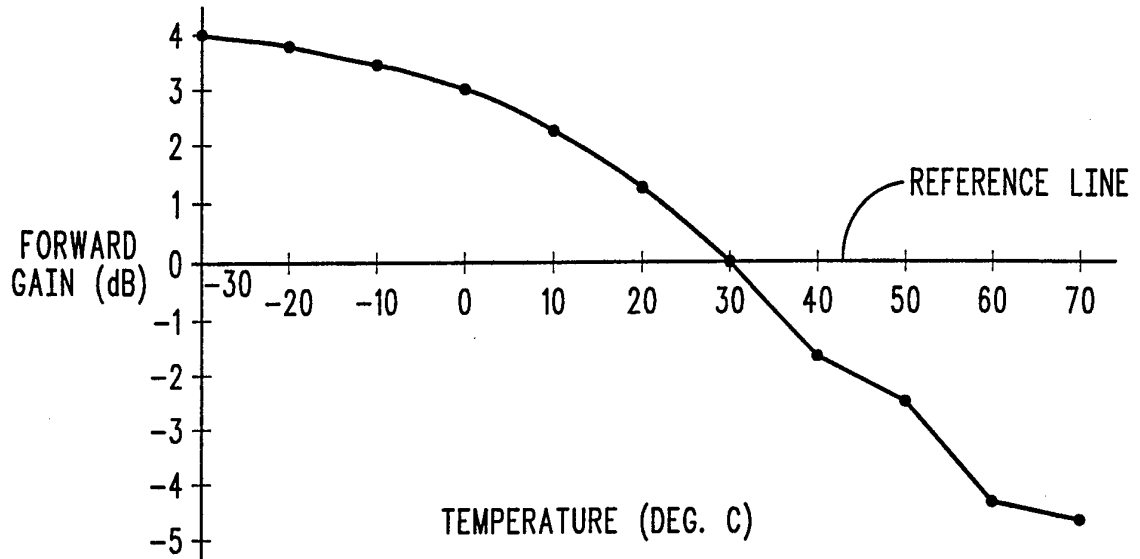

FIG. 3

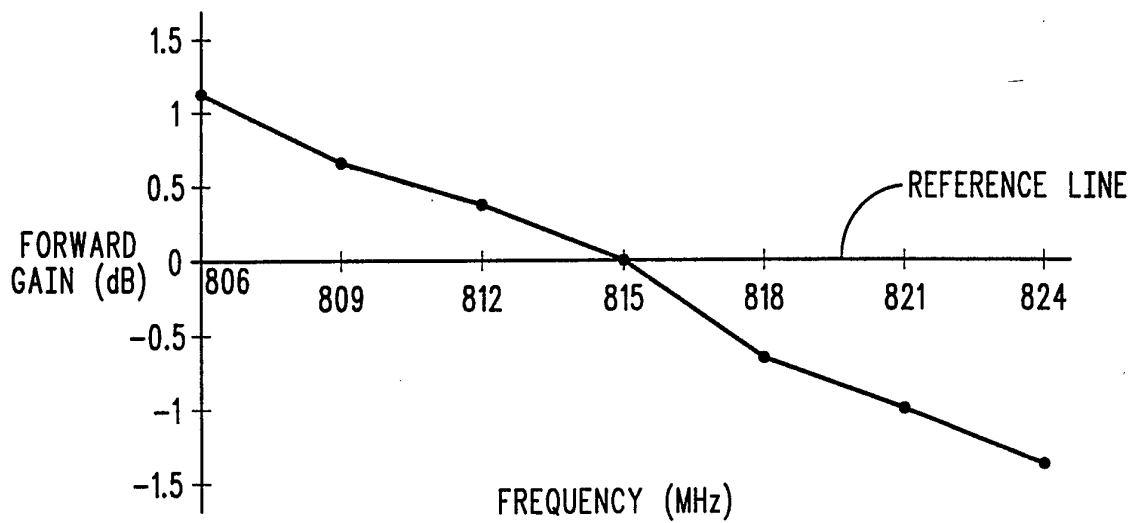

FIG. 4

4 / 5

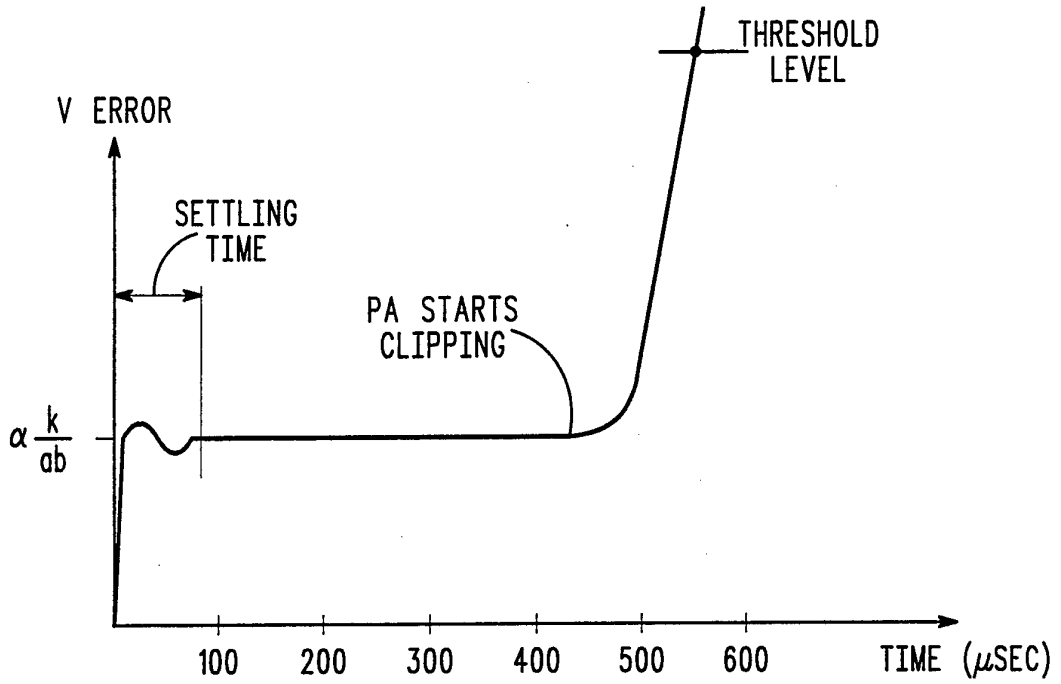

FIG. 5

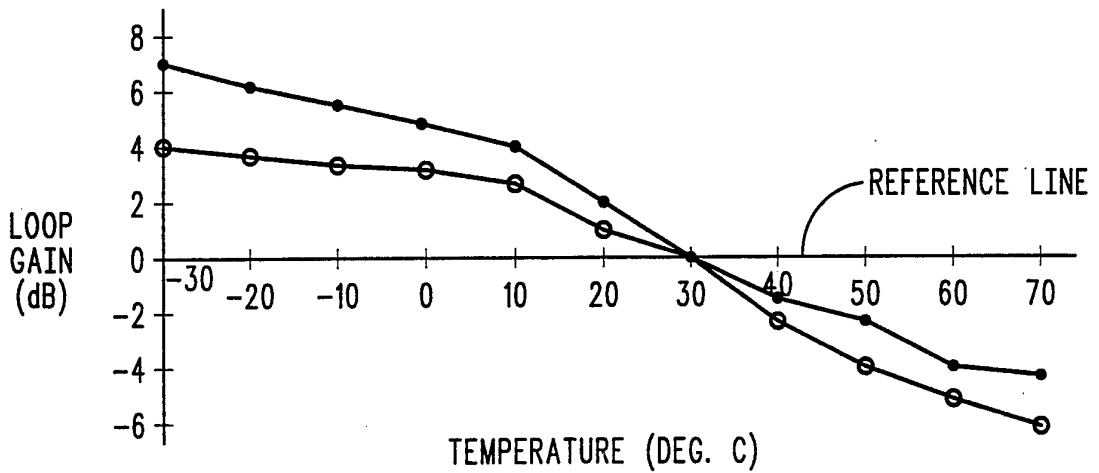

FIG. 6

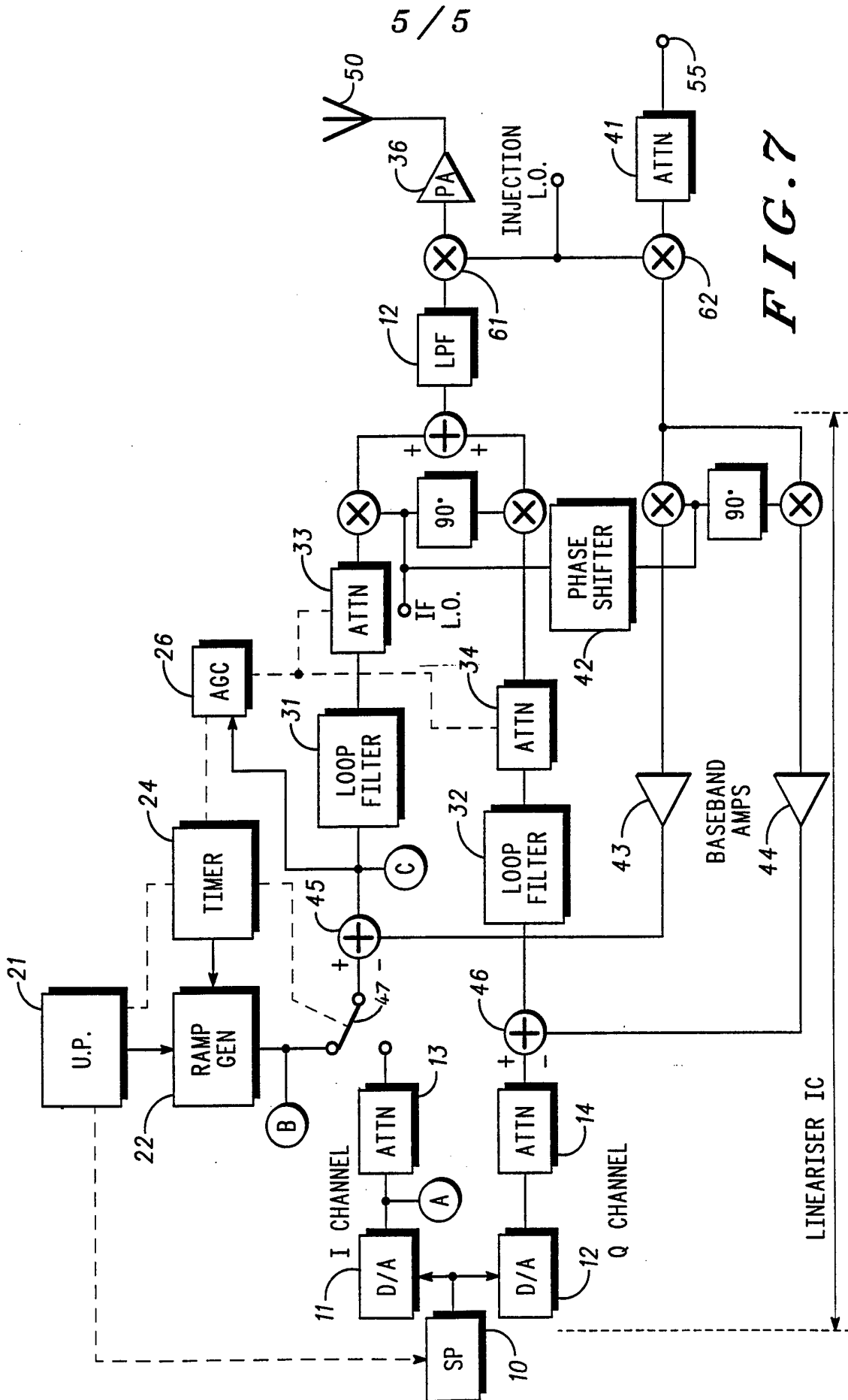

FIG. 7

**INTERNATIONAL SEARCH REPORT**

Inter. Application No  
**PCT/IB 94/00301**

**A. CLASSIFICATION OF SUBJECT MATTER**  
IPC 6 H03F1/32 H03G3/20

According to International Patent Classification (IPC) or to both national classification and IPC

**B. FIELDS SEARCHED**

Minimum documentation searched (classification system followed by classification symbols)  
IPC 6 H03F H03G

Documentation searched other than minimum documentation to the extent that such documents are included in the fields searched

Electronic data base consulted during the international search (name of data base and, where practical, search terms used)

**C. DOCUMENTS CONSIDERED TO BE RELEVANT**

Category *	Citation of document, with indication, where appropriate, of the relevant passages	Relevant to claim No.
A	US,A,5 066 923 (P.H. GAILUS ET AL) 19 November 1991 cited in the application see the whole document ---	1-11
A	EP,A,0 544 117 (NEC CORP.) 2 June 1993 see page 3, line 49 - page 5, line 36; figures 1,3,4 ---	1-11
A	PATENT ABSTRACTS OF JAPAN vol. 15, no. 394 (E-1119) 7 October 1991 & JP,A,31 059 468 (CANON INC) 9 July 1991 see abstract ---	1
P,X	WO,A,93 18581 (MOTOROLA) 16 September 1993 see the whole document -----	1-11

Further documents are listed in the continuation of box C.

Patent family members are listed in annex.

\* Special categories of cited documents :

- "A" document defining the general state of the art which is not considered to be of particular relevance
- "E" earlier document but published on or after the international filing date
- "L" document which may throw doubts on priority claim(s) or which is cited to establish the publication date of another citation or other special reason (as specified)
- "O" document referring to an oral disclosure, use, exhibition or other means
- "P" document published prior to the international filing date but later than the priority date claimed

- "T" later document published after the international filing date or priority date and not in conflict with the application but cited to understand the principle or theory underlying the invention
- "X" document of particular relevance; the claimed invention cannot be considered novel or cannot be considered to involve an inventive step when the document is taken alone
- "Y" document of particular relevance; the claimed invention cannot be considered to involve an inventive step when the document is combined with one or more other such documents, such combination being obvious to a person skilled in the art.
- "&" document member of the same patent family

Date of the actual completion of the international search

16 January 1995

Date of mailing of the international search report

19. 01. 95

Name and mailing address of the ISA

European Patent Office, P.B. 5818 Patentlaan 2  
NL - 2280 HV Rijswijk  
Tel. (+ 31-70) 340-2040, Tx. 31 651 epo nl,  
Fax: (+ 31-70) 340-3016

Authorized officer

Tyberghien, G

# INTERNATIONAL SEARCH REPORT

Information on patent family members

International Application No

PCT/IB 94/00301

Patent document cited in search report	Publication date	Patent family member(s)	Publication date
US-A-5066923	19-11-91	AU-B- 642610	21-10-93
		AU-A- 3525593	13-05-93
		AU-B- 636807	06-05-93
		AU-A- 8903391	26-05-92
		CN-A, B 1061123	13-05-92
		EP-A- 0507926	14-10-92
		JP-T- 5504454	08-07-93
		WO-A- 9208280	14-05-92
EP-A-0544117	02-06-93	JP-A- 5121958	18-05-93
		US-A- 5266906	30-11-93
WO-A-9318581	16-09-93	GB-A- 2265270	22-09-93
		CA-A- 2109063	03-09-93
		EP-A- 0584312	02-03-94
		JP-T- 6507772	01-09-94